

ZAXIS-3 series Short rear-end swing version

HITACHI

# ZAXIS

## 85 USBLC

## 85 USBLCN



### HYDRAULIC EXCAVATOR

- **Model Code:** ZX85USBLC-3 / ZX85USBLCN-3
- **Engine Rated Power:** 39.4 kW (52.8 HP)
- **Operating Weight:** ZX85USBLC-3: 8 070 - 8 690 kg  
ZX85USBLCN-3: 8 020 - 8 480 kg
- **Backhoe Bucket:** SAE, PCSA Heaped: 0.13 - 0.33 m<sup>3</sup>  
CECE, Heaped: 0.12 - 0.29 m<sup>3</sup>

# The Power to Perform

The ZAXIS-3 series is a new generation of excavators designed to provide more efficient power, productivity and improved operator comfort. By listening carefully to the wishes of the end-user, HITACHI not only understands your business, but also provides the reliable solutions you've been looking for.

## NEW AND IMPROVED

- **Performance:**  
5% higher production
- **Comfort:**  
Excellent visibility  
Enhanced controllability  
Lower noise level
- **New equipment:**  
Standard satellite communication system  
Standard theft deterrent system  
Rear view camera (optional)
- **Reduced running costs:**  
Lower fuel consumption per m<sup>3</sup>  
Improved durability and reliability

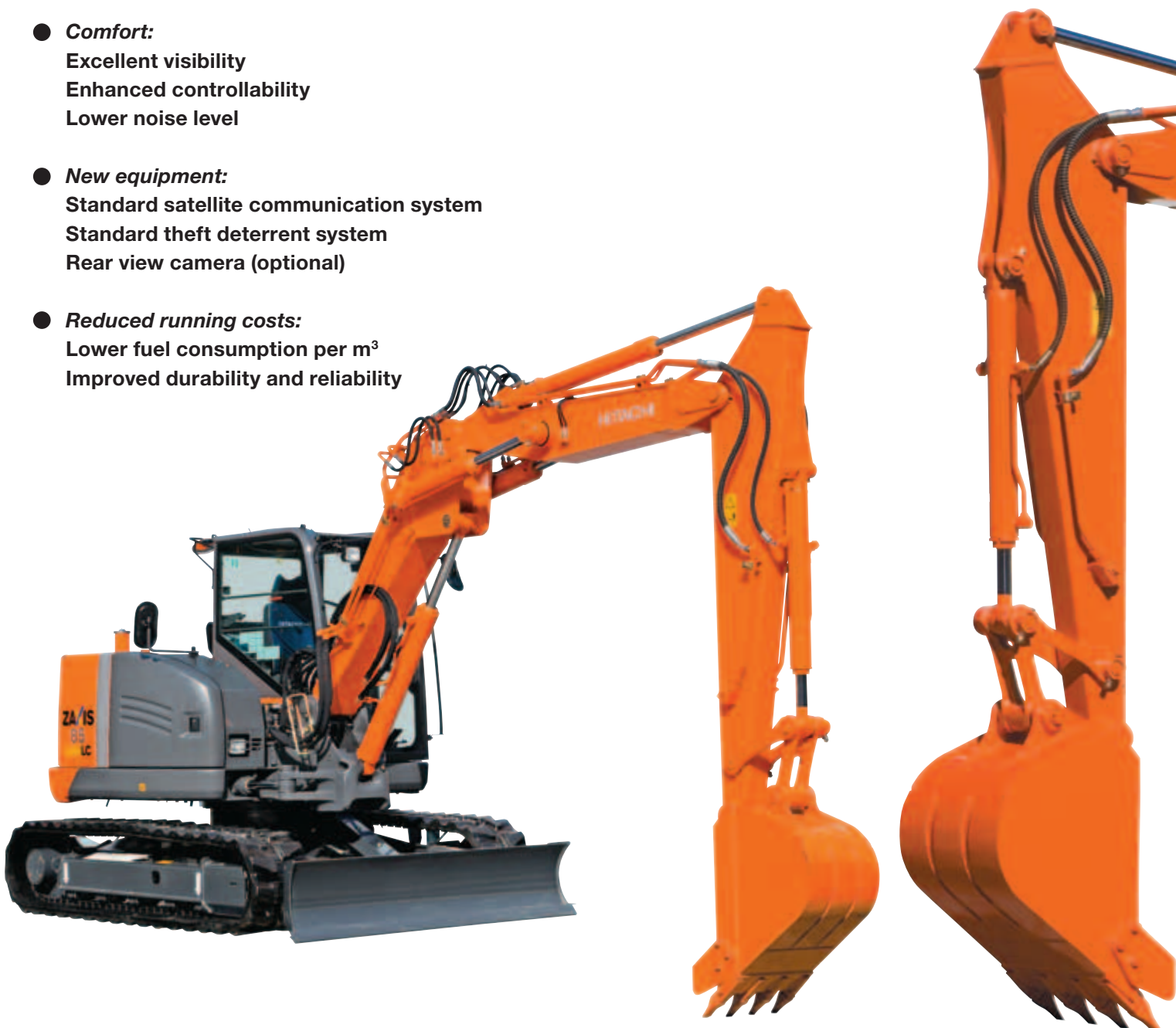

ZX85USBLC-3 2-piece boom with an optional 450 mm rubber shoe installed.

### **Productivity**

E-mode  
Speed sensing control  
Improved swing ability  
Improved mobility  
Improved blade crowding performance

**Page 4-5**

### **Operator comfort**

High visibility inside cab  
Short stroke levers  
Comfort designed seat  
Improved controllability and operator comfort

**Page 6-7**

### **Multi function monitor**

Maintenance support  
Theft deterrent system  
Rear view camera (optional)

**Page 8-9**

### **Durability and reliability**

Strengthened upperstructure  
Strengthened undercarriage  
Strengthened front attachment

**Page 10-11**

### **Maintenance**

Conveniently located inspection points  
Wide opened engine cover  
Parallel arrangement of the cooling pack

**Page 12-13**

### **Safety measures**

CRES II cab  
Cab right protection bars  
Pilot control shut-off lever  
Engine stop knob

**Page 14**

### **Environment measures**

Array of low noise mechanisms  
Ecological design

**Page 15**

### **Parts & service**

**Page 16**

### **e-Service Owner's site**

**Page 17**

### **Specifications**

**Page 18-23**

- **The new engine complies with the Emission Regulations EU Stage III A**
- **The advanced low noise design complies with the EU noise regulation 2000 / 14 / EC, STAGE II**



*Notes: The pictures in this brochure show ZX85USBLC-3 Mono block boom excavations with a 2.12 m arm, 600 mm grouser shoe and an optional blade attachment installed. Some of the pictures in this brochure show an unmanned machine with attachments in an operating position. These were taken for demonstration purposes only and the actions shown are not recommended under normal operating conditions.*

# Boosted Productivity

Short-tail-swing makes possible efficient operations in various confined worksites. Efficient hydraulic system and new intercooled turbocharger diesel engine were developed for ZAXIS-3. These advanced technologies are at work to yield bigger output with higher fuel efficiency.

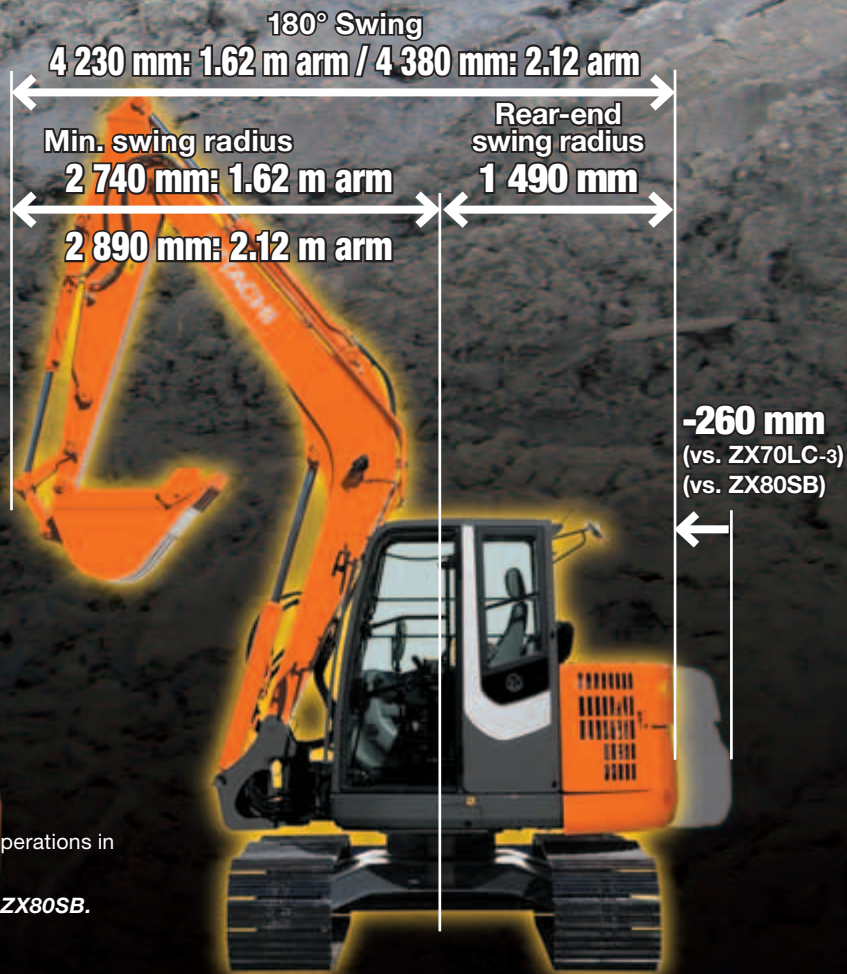

## Applicable in Various Jobsites

Short 1 490 mm rear-end swing radius promises efficient operations in confined spaces.

- Rear-end swing radius is shorter than of ZX70LC-3 or ZX80SB.

\*In figure, machines are expressed by model codes for presentation.  
The photo shows an excavator with a 2.12 m arm and 600 mm grouser shoe installed.

## More production, less fuel consumption

### Increased Production

A combination of the hydraulic system (HIOS<sup>II</sup>) and new intercooled turbocharger engine allows the efficient use of hydraulic pressure to increase speeds of actuators and boost production with higher fuel efficiency. The productivity is increased 5% in comparison to previous model ZAXIS-1.

*\*Human & Intelligent Operation System*

### E-mode

The E mode and P mode can be selected to suit job needs. The E mode can save fuel consumption by up to 12% compared to the previous model's P mode, while yielding similar production.

### Increase in Swing Torque and Traction Force

Swing torque and traction force are increased significantly.

**- Swing torque 9% UP**

**- Traction force 8% UP**

## Efficient hydraulic control

### Hydraulic System

The Hydraulic System elicits more user satisfaction than other models due to its greater operator comfort and ease of operability. During arm roll-in operations, the hydraulics of 3 pumps are merged, allowing for quick leveling operations. Depending on the operations, usage of the 3 pumps are automatically switched, offering excellent operability. It supports stability and combined operability, such as speed balance and land clearing.

### Speed Sensing Control

A speed sensing system is used for hydraulic horsepower control. The hydraulic pump delivery flow, which varies with changes in engine RPM according to the load, is controlled. This means efficient use of engine horsepower, and also contributes to a reduction in fuel consumption.

## Development concept of new engine

### Intercooled Turbocharger Engine

The new intercooled turbocharger engine is developed and built to comply with the rigorous Emission Regulations enforced in 2008 in U.S and EU. This new engine contributes to environmental preservation. At the same time it realizes high durability and low fuel consumption by adapting the latest advanced engine technology.



### Cooled EGR\* System

Exhaust gas is partially mixed with intake air to lower combustion temperature for reducing NOx and fuel consumption. What's more, the EGR cooler cools down exhaust gas to increase air concentration for complete combustion, reducing PM\*\* (diesel plume).

*\*Exhaust Gas Recirculation*

*\*\*Particulate Matter*

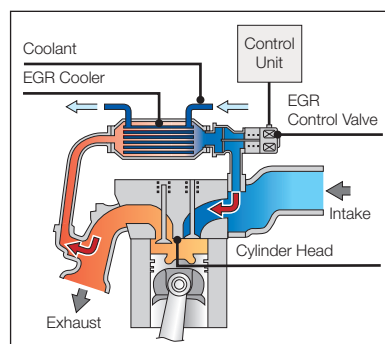

## Improved crowding performance

### Reshaped Blade (optional)

The blade is reshaped for crowding without loss.

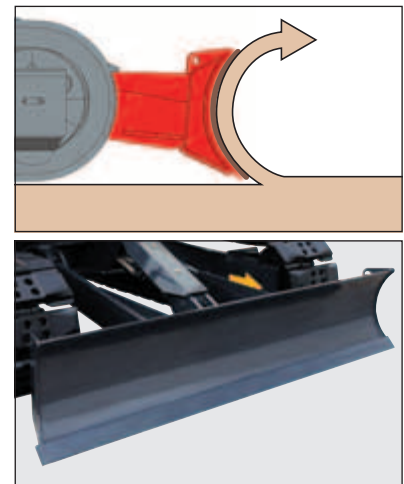

## A New Standard in Operator Comfort

The operator's seat of the ZAXIS-3 series gives the operator an excellent view of the jobsite. On the widescreen color LCD monitor the operator can see machine conditions. Ample legroom, short stroke levers and a large seat ensure optimum working conditions for the operator during long hours.





*The photo shows an excavator with an optional blade (blade lever) installed.*

The ZAXIS-3 series cab has been redesigned to meet demands of customers. Using the glass door increases visibility, which is effective when the front is in offset position. From the operator's seat the operator has an excellent view of the jobsite. On the widescreen color LCD monitor the operator can see machine conditions and with the rear view camera (optional), what is behind the machine. Ample legroom, short stroke levers and a suspension seat ensure optimum working conditions. The seat features horizontal, vertical adjustments and has a backrest contoured for comfort, with a HITACHI logo.



Short stroke levers allow for continuous operation with less fatigue. Three switches on the lever (optional) can be set to operate attachments other than buckets. The cab is pressurized to keep out dust. Noise and vibrations are kept to a minimum due to the elastic mounts, filled with silicone oil, the cab rests on.

Visibility is improved especially for the left downward view. Sliding front window on the enable direct communication between operator and other workers. Travel pedals can be folded when not in use for wider legspace. A flat floor allows for easy cleaning. Ergonomic controls and switches, fully automatic air conditioner and a radio complete the package.

# Embedded Information Technology

The ZAXIS-3 series is equipped with a widescreen color LCD monitor with adjustable contrast for day and night shifts. With the monitor the operator can check maintenance intervals and connect to the rear view camera (optional). A theft deterrent system and multi-language selection is also available.

## Multi function monitor



The color LCD monitor, located in the cab, indicates coolant temperature, fuel level, and maintenance data. It also allows one-touch adjustment of the attachment. The display can also be adjusted to day or night shift.

## Maintenance support

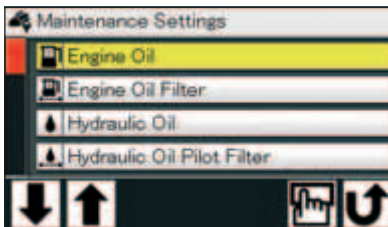

Replacement timing of hydraulic oil and fuel filters is alerted to the operator through the LCD monitor according to the schedule preset by the user each time when turning the key switch. The scheduled maintenance can prevent the failure of the machine.

## Multi-language selection



The menu allows selection from 12 languages.





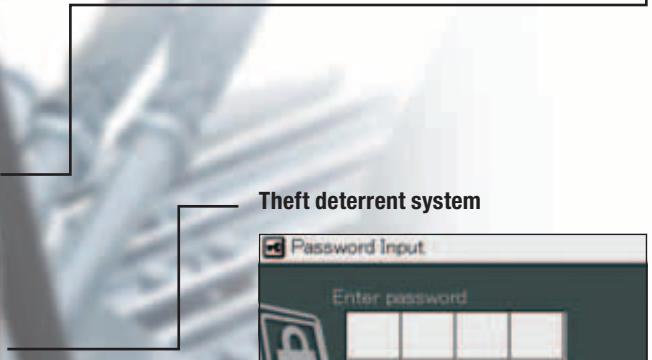

**Theft deterrent system**

The electronic immobiliser requires the entry of a password code to the multifunctional monitor each time when starting the engine to prevent theft and vandalism.

**Rear view camera (optional)**



The widescreen color LCD, in tandem with the rear view camera on the counterweight, provides a convenient view of the area behind the unit. The rear view camera automatically works when travelling backward, and can also be manually turned on with a select switch on the monitor.



## A Solid Base for a Long Life

HITACHI's technology is built on a wealth of experience and know-how from a variety of demanding conditions around the world. The undercarriage of the ZAXIS 85USBLC has become much stronger. Improved construction and enlarged box sections make this machine more durable.



## Strengthened Upperstructure

The new ZAXIS excavator now has a D-section frame skirt, which was highly acclaimed in previous models. As a result of this D-section frame skirt, rigidity and durability in the upper machinery are greatly improved.

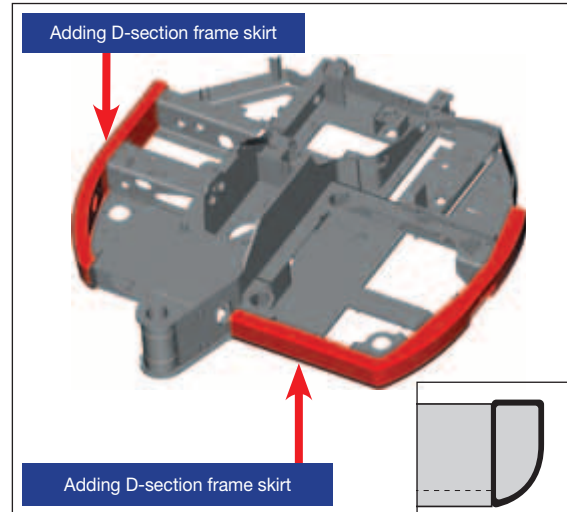

## Strengthened X beam

One-piece upper and lower plates are utilized instead of conventional 4-piece plates, eliminating welds. This increases strength of the track frame.

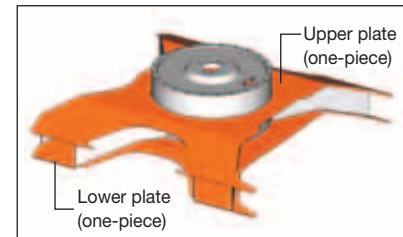

## Strengthened front attachment

At arm-bucket joint, the arm top is hardened with WC thermal spraying (Tungsten-Carbide) for greater wear resistance at its contact surface with bucket, reducing jerking.



WC Thermal spraying

## Simplified Maintenance

The ZAXIS-3 series meet customer demands for simplified maintenance. Regular maintenance is the key for keeping equipment in top condition, which can help to prevent costly downtime. In addition, a regularly serviced machine has higher residual value. There are many service features to be found on the ZAXIS-3 series.



## Conveniently located inspection points

Wide doors give access, from ground level, to the fuel filter, water separator and engine oil filter.

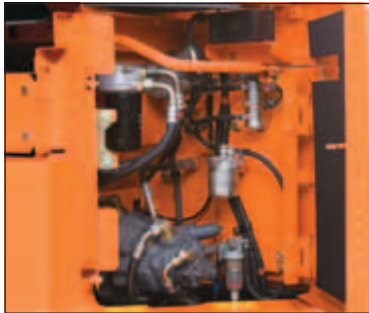

## Parallel arrangement of the cooling pack

The oil cooler and radiator are laid out in a parallel arrangement, instead of the conventional in-line arrangement. This parallel arrangement is significantly easier to clean around the engine.

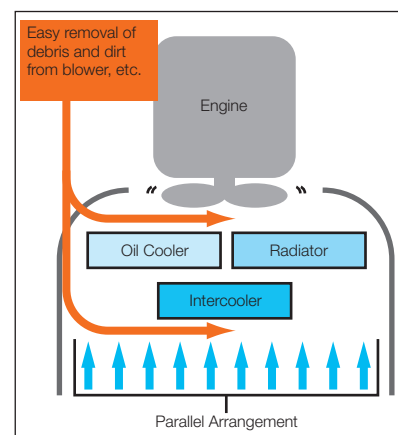

## Extended oil and filter change intervals

Front Pin Lubricating Intervals and Consumables Replacement		
Lubricant	Bucket	500 h
	Boom Foot	500 h
	Front	500 h
Consumables	Engine Oil	500 h
	Engine Oil Filter	500 h
	Hydraulic Oil	5 000 h
	Hydraulic Oil Filter	1 000 h
	Fuel Filter	500 h

The fuel tank is a 135 L short-tail-swing version, the same capacity as that used in standard equipment. With 135 L, refueling doesn't have to be done as often. The oil and filter change intervals have been extended considerably, reducing maintenance time and expenses. Engine oil consumption is lower. Hydraulic oil can be used up to 5 000 hours.

# Safety Features

Ensuring the safety of the operator and other workers on the jobsite is an important concern for HITACHI. That is why the ZAXIS-3 series has a number of safety features including a new reinforced cab and shut-off mechanisms for engine and pilot controls.



## CRES II cab

The CRES II cab is designed to help with “just in case” protection for the operator. Safety in case of tipping is improved. This structure conforms to ROPS specifications (ISO 12117-2), which stipulate the structure that protects the operator in the event of a hydraulic excavator roll-over. The cab top, for instance, can withstand about 1.6 times conventional load when side load is applied to the cab top until its deformation reaches 200 mm.



withstanding load: 1.6-fold increase

## Additional features

### Cab right protection bars



### Evacuation hammer



### Engine stop knob



### Pilot control shut-off lever

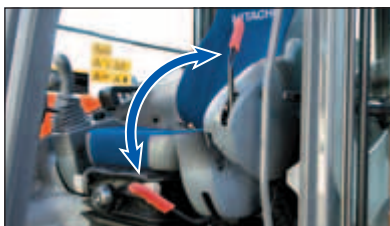

### OPG top guard, Level II



(optional)

### Retractable seat belt



Other features include a retractable seat belt, evacuation hammer and emergency engine stop knob. A shut-off lever for pilot control helps to prevent unintentional movements. In addition, a Falling Object Protective Structure (OPG top guard, Level II) guard is optionally available. For the cab windows there is a choice of laminated or tempered glass.

# Environmental Features

HITACHI acts responsibly when it comes to the environment. Our production facilities have ISO 14001 certification. The HITACHI machine is lead free and has a low-noise design, therefore HITACHI customers get one of the most environmentally considerate hydraulic excavators available today.



## A cleaner machine

The ZAXIS-3 series is equipped with a clean but powerful engine to comply with Stage III A, and Tier 3. An engine emission regulations effective in the European Union and U.S. EPA from 2008. Reduced particulate matter (PM) output and lower nitrogen oxide (NOx) levels.

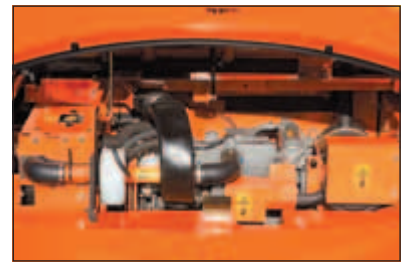

## A quieter machine

Many features contribute to noise reduction in the new ZAXIS. Firstly, the fan with linear clutch responds to the engine temperature: the rotational speed of the fan increases smoothly as the temperature of the engine increases. This control reduces noise in light-load operations, as the fan rotational speed does not increase beyond what is necessary. This also means that no load is placed on the engine, reducing fuel consumption. The cylinder block and ladder frame in the new engine are strengthened, reducing engine noise. Due to intercooled turbo charging and the optimization of fuel injection timing, exhaust noise is reduced by 10 dB (compared to previous models).



## A recyclable machine

All resin parts are marked to facilitate recycling. The machine is completely leadfree. The radiator and oil cooler are made from aluminium and all wires are leadless. In addition, biodegradable hydraulic oil is available for jobsites where special environmental care is required.



# Parts & Service

Over the years, we have gained experience in one of the most competitive service markets in the world - Japan. Using our know-how in dealing directly with customers, we have created a worldwide support system that is highly capable.

## Parts

HITACHI only offers genuine high quality parts. We guarantee that these parts have high performance and long life. We manage around 1 000 000 types of parts all around the world. They are designed and built to be the best match for your HITACHI equipment. HITACHI has a global parts distribution network that makes sure you get what

you need as quickly as possible. We have more than 150 dealers worldwide who provide the closest support for your needs. In most cases, your dealer will have the replacement part that you require. If a dealer does not have a certain part, he can order it from four fully stocked parts depots located across the world. These distribution

centres are all connected by an on-line system that gives them access to shared information on stocks, such as the number and type of available parts. The depots, which in turn are stocked by a parts centre in Japan, minimize delivery time and enable you to get your parts as efficiently and quickly as possible.

## Service

Our goal is to “keep customer equipment at a maximum performance level”. To fulfil this goal, we have set more than 150 dealers all over the world. They have highly trained technicians, and provide a number of support programs. HITACHI provides a unique extended warranty program

called HITACHI Extended Life Program, or HELP. To minimize downtime during troubleshooting, we developed a PDA based diagnostic system called “Dr.ZX”. To keep our customers’ equipment in top running shape, good service is indispensable. We believe personnel training is the key to

providing the best service. If you would like more information regarding parts and/or service, please ask your nearest HITACHI dealer. Not all programs and/or services are available in every market or region.



# Remote fleet management with e-Service Owner's Site

**OWNER'S**  
e-Service Owner's Site

Reduce maintenance effort and costs for your machine fleet with e-Service Owner's Site; latest machine information of each of your machines available on-line, in your office.



## e-Service Owner's Site features

### Operation

Remote access to all relevant machine operation information such as daily operating hours and machine fuel level as well as historically cumulated temperatures and pressures.

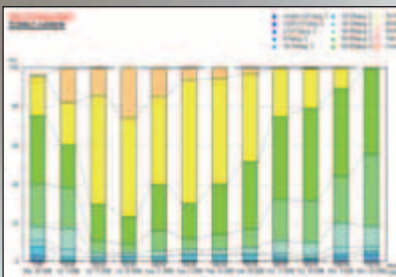

### Maintenance

For each machine, maintenance history as well as recommended maintenance due is displayed in one view, allowing for accurate and efficient fleet maintenance management.



### Location

In addition to any general GPS function, GIS (Geographical Information System) will not only show the geographical position of each machine with immediate serial number identification, it will also allow for dedicated multiple machine searches using specific operational information as search criteria.

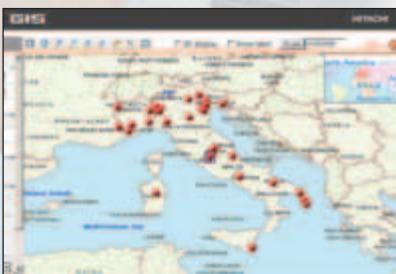

**Check and monitor each of your machines from your office**

**Enhanced service support from your local dealer**

**Actual geographical location of each of your machines**

e-Service Owner's Site is an on-line fleet management tool offered by HCME to each of its customers. It will present all operational information and location of your machines on a PC in your office, giving you an up to date overview of your machines, allowing for full fleet control. Each machine will regularly send its operational data to a satellite and from there, via a ground station to a Hitachi server. The data collected in the server will then be processed and directed to each customer around the world. Your machine information will be available through a secure internet connection for you and your dealer. This communication chain is operational 24h a day, each day of the year. It will support your job planning, help you maintain your machine and allow for enhanced service and trouble shooting support by your local dealer, all directly contributing to reduce downtime and increase the cost performance of your fleet.

All new ZAXIS-3 and ZW machines supplied by HCME will have a satellite communication unit installed as standard\*, meaning each owner can directly enjoy the benefits of e-Service Owner's Site. Your local dealer will be able to give you access to e-Service Owner's Site.

*Optimizing fleet management  
Accurate maintenance planning  
Job planning support tool  
Swift trouble shooting*

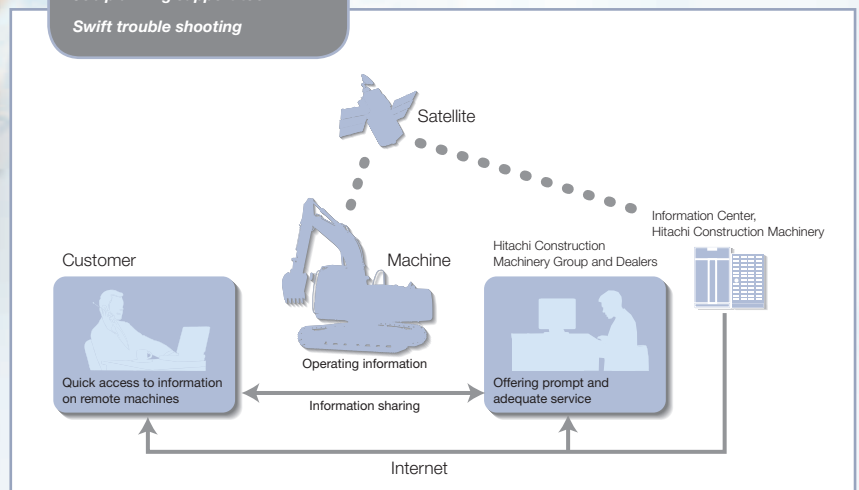

\* (1) Satellite communication may be forbidden by the local regulatory standards (including safety standards) and legal requirements of the particular country where you wish to use it. Please contact HITACHI dealer for details.  
(2) Satellite communication basically allows for worldwide coverage. Contact your local dealer for the latest situation on actual satellite communication availability for your country or specific jobsite.  
(3) If transmission of the satellite signal is hindered in any way, satellite communication may not be possible.

# SPECIFICATIONS

## ENGINE

Model .....	Isuzu 4U-4LE2X
Type .....	4-cycle water-cooled, direct injection
Aspiration .....	Turbocharged, intercooled
No. of cylinders .....	4
Rated power	
ISO 9249, net .....	39.4 kW (52.8 HP) at 2 000 min <sup>-1</sup> (rpm)
EEC 80/1269, net ..	39.4 kW (52.8 HP) at 2 000 min <sup>-1</sup> (rpm)
SAE J1349, net .....	39.4 kW (52.8 HP) at 2 000 min <sup>-1</sup> (rpm)
Maximum torque .....	215 N·m (21.9 kgf·m) at 1 500 min <sup>-1</sup> (rpm)
Piston displacement ..	2.179 L
Bore and stroke .....	85 mm x 96 mm
Batteries .....	2 x 12 V / 52 Ah

## HYDRAULIC SYSTEM

- Swing-independent 3-pump hydraulic system
- OHS (Optimum Hydraulic System) assures fully independent and combined operations
- Automatic 2-speed motor increases traction force and travel speed
- Engine speed sensing system

Main pumps .....	3 variable displacement axial piston pumps
Maximum oil flow ..	2 x 79.2 L/min
	1 x 61.6 L/min
Pilot pump .....	1 gear pump
Maximum oil flow ..	22.0 L/min

## Hydraulic Motors

Travel .....	2 variable displacement axial piston motors
Swing .....	1 axial piston motor

## Relief Valve Settings

Implement circuit .....	26.0 MPa (265 kgf/cm <sup>2</sup> )
Swing circuit .....	25.0 MPa (255 kgf/cm <sup>2</sup> )
Travel circuit .....	31.4 MPa (320 kgf/cm <sup>2</sup> )
Pilot circuit .....	3.9 MPa (40 kgf/cm <sup>2</sup> )

## Hydraulic Cylinders

High-strength piston rods and tubes. Cylinder cushion mechanisms provided in boom, arm, boom swing cylinders to absorb shock at stroke ends.

## Dimensions

	Quantity	Bore	Rod diameter
Boom	1	115 mm	65 mm
Arm	1	95 mm	60 mm
Bucket	1	85 mm	55 mm
Boom swing	1	110 mm	60 mm
Positioning	2	110 mm	60 mm

## Hydraulic Filters

Hydraulic circuits use high-quality hydraulic filters. A suction filter is incorporated in the suction line, and full-flow filters in the return line and swing/travel motor drain lines.

## CONTROLS

Pilot controls. Hitachi's original shockless valve and quick warm-up system built in the pilot circuit.

Implement levers .....	2
Travel levers with pedals .....	2
Boom swing pedals .....	1

## UPPERSTRUCTURE

### Revolving Frame

Welded sturdy box construction, using heavy-gauge steel plates for ruggedness. D-section frame for resistance to deformation.

### Swing Device

Axial piston motor with planetary reduction gear is bathed in oil. Swing circle is single-row, shear-type ball bearing with induction-hardened internal gear. Internal gear and pinion gear are immersed in lubricant. Swing parking brake is spring-set/hydraulic-released disc type.

Swing speed .....	10.5 min <sup>-1</sup> (rpm)
Swing torque .....	16.0 kN·m (1 630 kgf·m)

### Operator's Cab

Independent spacious cab, 1 065 mm wide by 1 655 mm high, conforming to ISO\* Standards. Reinforced glass windows on 4 sides for visibility. Front windows (upper and lower) can be opened. Reclining seat with armrests; adjustable with or without control levers.

\* International Standardization Organization

## UNDERCARRIAGE

### Tracks

Tractor-type undercarriage. Welded track frame using selected materials. Side frame welded to track frame. Lubricated track rollers, idlers, and sprockets with floating seals. Track shoes with triple grousers made of induction-hardened rolled alloy. Heat-treated connecting pins with dirt seals. Hydraulic (grease) track adjusters with shock-absorbing recoil springs.

### Numbers of Rollers and Shoes on Each Side

Upper rollers .....	1
Lower rollers .....	5
Track shoes .....	40

### Travel Device

Each track driven by 2-speed axial piston motor through planetary reduction gear for counterrotation of the tracks. Sprockets are replaceable. Parking brake is spring-set/hydraulic-released disc type. Travel shockless relief valve built in travel motor absorbs shocks when stopping travel.

Automatic transmission system: High-Low.

Travel speeds .....	High: 0 to 5.0 km/h
	Low: 0 to 3.1 km/h

Maximum traction force .....	71.0 kN (7 240 kgf)
------------------------------	---------------------

Gradeability .....	70% (35 degree) continuous
--------------------	----------------------------

## WEIGHTS AND GROUND PRESSURE

### ZX85USBLC-3 with Monoblock boom

Equipped with Monoblock boom, 1.62 m arm and 0.28 m<sup>3</sup> (SAE, PCSA heaped) bucket.

Shoe type	Shoe width	Operating weight	Ground pressure
Triple grouser	450 mm	8 080 kg	35 kPa (0.36 kgf/cm <sup>2</sup> )
	600 mm	8 260 kg	27 kPa (0.28 kgf/cm <sup>2</sup> )
Pad	450 mm	8 070 kg	35 kPa (0.36 kgf/cm <sup>2</sup> )
Rubber	450 mm	8 100 kg	35 kPa (0.36 kgf/cm <sup>2</sup> )

### ZX85USBLCN-3 with Monoblock boom

Equipped with Monoblock boom, 1.62 m arm and 0.28 m<sup>3</sup> (SAE, PCSA heaped) bucket.

Shoe type	Shoe width	Operating weight	Ground pressure
Triple grouser	450 mm	8 030 kg	35 kPa (0.36 kgf/cm <sup>2</sup> )
Pad	450 mm	8 020 kg	35 kPa (0.36 kgf/cm <sup>2</sup> )
Rubber	450 mm	8 050 kg	35 kPa (0.36 kgf/cm <sup>2</sup> )

### ZX85USBLC-3 with 2-piece boom

Equipped with 2-piece boom, 1.62 m arm and 0.28 m<sup>3</sup> (SAE, PCSA heaped) bucket.

Shoe type	Shoe width	Operating weight	Ground pressure
Triple grouser	450 mm	8 510 kg	37 kPa (0.38 kgf/cm <sup>2</sup> )
	600 mm	8 690 kg	28 kPa (0.29 kgf/cm <sup>2</sup> )
Pad	450 mm	8 500 kg	37 kPa (0.38 kgf/cm <sup>2</sup> )
Rubber	450 mm	8 530 kg	37 kPa (0.38 kgf/cm <sup>2</sup> )

### ZX85USBLCN-3 with 2-piece boom

Equipped with 2-piece boom, 1.62 m arm and 0.28 m<sup>3</sup> (SAE, PCSA heaped) bucket.

Shoe type	Shoe width	Operating weight	Ground pressure
Triple grouser	450 mm	8 460 kg	37 kPa (0.38 kgf/cm <sup>2</sup> )
Pad	450 mm	8 450 kg	36 kPa (0.37 kgf/cm <sup>2</sup> )
Rubber	450 mm	8 480 kg	37 kPa (0.38 kgf/cm <sup>2</sup> )

Weights of the basic machines [including 1 480 kg counterweight and triple grouser shoes and blade, excluding front-end attachment, fuel, hydraulic oil, engine oil and coolant etc.] are:

ZX85USBLC-3 ..... 5 330 kg with 450 mm shoes  
 ZX85USBLCN-3 ..... 5 280 kg with 450 mm shoes

## SERVICE REFILL CAPACITIES

Fuel tank (ZX85USBLC-3).....	135.0 L
Fuel tank (ZX85USBLCN-3).....	115.0 L
Engine coolant .....	10.0 L
Engine oil .....	12.0 L
Travel device .....	1.2 L
(each side)	
Hydraulic system .....	100.0 L
Hydraulic oil tank .....	56.0 L

## BACKHOE ATTACHMENTS

Boom and arms are of welded, box-section design. 1.62 m and 2.12 m arms are available.

### Buckets

Capacity		Width without side cutters	Weight
SAE, PCSA heaped	CECE heaped		
0.13 m <sup>3</sup>	0.12 m <sup>3</sup>	360 mm	140 kg
0.17 m <sup>3</sup>	0.15 m <sup>3</sup>	450 mm	170 kg
0.19 m <sup>3</sup>	0.17 m <sup>3</sup>	490 mm	180 kg
0.23 m <sup>3</sup>	0.20 m <sup>3</sup>	560 mm	190 kg
0.28 m <sup>3</sup>	0.24 m <sup>3</sup>	660 mm	210 kg
0.33 m <sup>3</sup>	0.29 m <sup>3</sup>	770 mm	230 kg

## SOUND LEVEL RESULTS (2000/14/EC)

LwA: sound-power level of airborne noise

LpA: sound level at operator's station

Unit: dB(A)

	LwA	LpA
ZX85USBLC-3	98	72
ZX85USBLCN-3		

# SPECIFICATIONS

## DIMENSIONS : MONOBLOCK BOOM

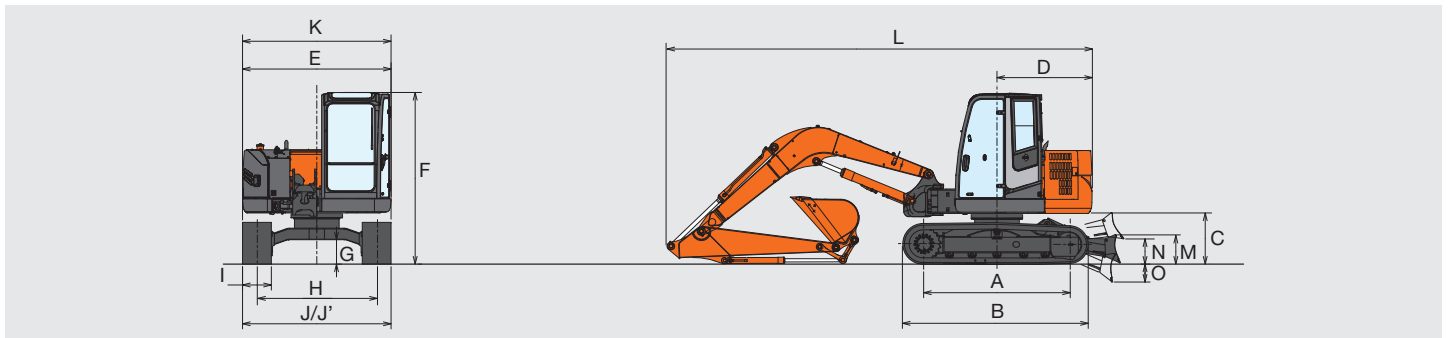

Unit: mm

	ZX85USBLC-3	ZX85USBLCN-3
A Distance between tumblers	2 290	
B Undercarriage length	2 920	
*C Counterweight clearance	760	
D Rear-end swing radius	1 490	
E Overall width of upperstructure	2 320	2 260
F Overall height of cab	2 690	
*G Min. ground clearance	360	
H Track gauge	1 870	1 810
I Track shoe width	G 450	
J Undercarriage width	2 320	2 200
J' Blade width	2 320	2 200
K Overall width	2 320	2 260
L Overall length		
With 1.62 m arm	6 640	
With 2.12 m arm	6 810	
M Blade height	460	
N Max. raising height above ground	360	
O Max. lowering depth from ground	300	

\* Excluding track shoe lug    G: Triple grouser shoe

## WORKING RANGES : MONOBLOCK BOOM

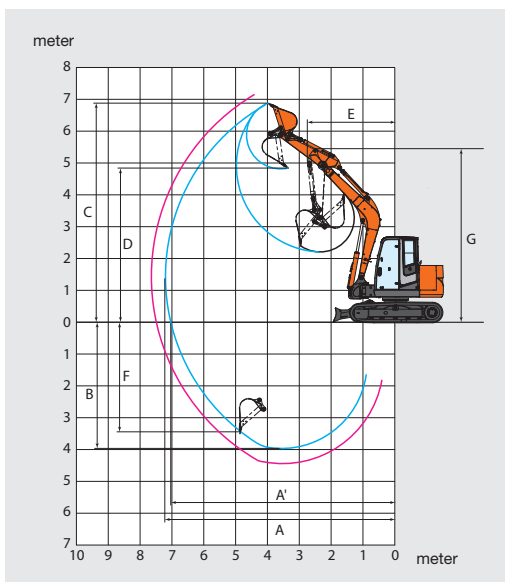
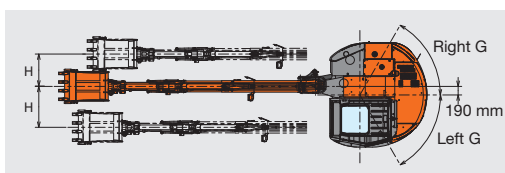

Unit: mm

	ZX85USBLC-3 / ZX85USBLCN-3	
	1.62 m	2.12 m
A Max. digging reach	7 210	7 700
A' Max. digging reach (on ground)	7 050	7 550
B Max. digging depth	3 970	4 470
C Max. cutting height	6 810	7 180
D Max. dumping height	4 790	5 140
E Min. swing radius	2 740	2 890
F Max. vertical wall	3 450	4 030
G Max. boom-swing angle	Left 60° / Right 60°	
H Max. offset distance	Left 910 / Right 720	
Bucket digging force ISO	55 kN (5 600 kgf)	
Bucket digging force SAE: PCSA	47 kN (4 800 kgf)	
Arm crowd force ISO	38 kN (3 900 kgf)	32 kN (3 300 kgf)
Arm crowd force SAE: PCSA	36 kN (3 700 kgf)	31 kN (3 200 kgf)

Excluding track shoe lug

## DIMENSIONS : 2-PIECE BOOM

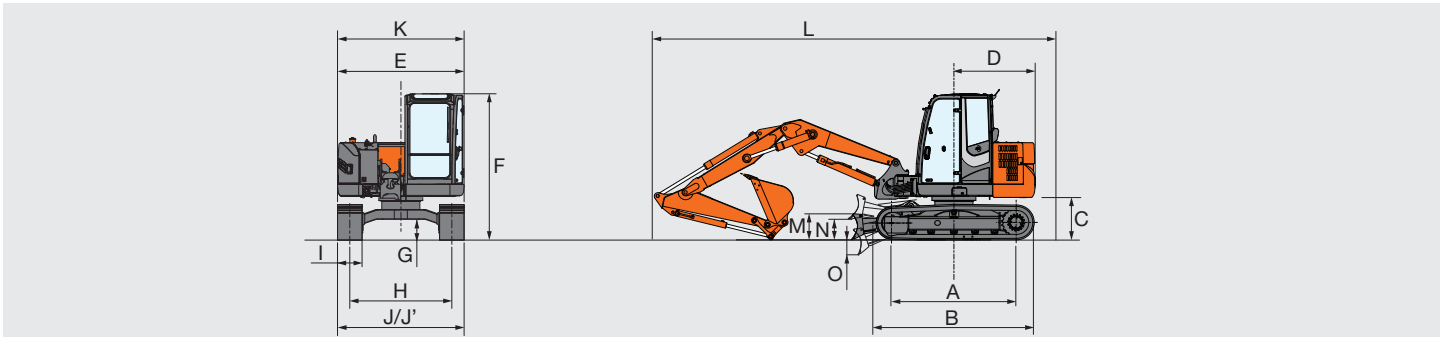

Unit: mm

	ZX85USBLC-3	ZX85USBLCN-3
A Distance between tumblers	2 290	
B Undercarriage length	2 920	
*1 C Counterweight clearance	760	
D Rear-end swing radius	1 490	
E Overall width of upperstructure	2 320	2 260
F Overall height of cab	2 690	
*1 G Min. ground clearance	360	
H Track gauge	1 870	1 810
I Track shoe width	G 450	
J Undercarriage width	2 320	2 200
J' Blade width	2 320	2 200
K Overall width	2 320	2 260
L Overall length		
With 1.62 m arm	6 990	
With 2.12 m arm	6 630*2	
M Blade height	460	
N Max. raising height above ground	360	
O Max. lowering depth from ground	300	

\*1 Excluding track shoe lug

\*2 Position cylinder length is 1 100mm and blade is backward

G: Triple grouser shoe

## WORKING RANGES : 2-PIECE BOOM

Unit: mm

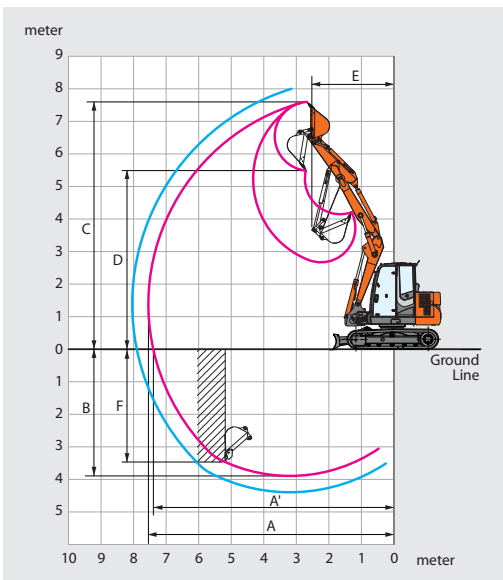
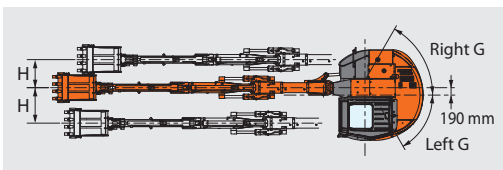

	ZX85USBLC-3 / ZX85USBLCN-3	
	1.62 m	2.12 m
A Max. digging reach	7 510	8 000
A' Max. digging reach (on ground)	7 360	7 860
B Max. digging depth	3 890	4 390
C Max. cutting height	7 620	8 070
D Max. dumping height	5 510	5 960
E Min. swing radius	2 480	2 910
F Max. vertical wall	3 460	3 960
G Max. boom-swing angle	Left 60° / Right 60°	
H Max. offset distance	Left 910 / Right 720	
Bucket digging force ISO	55 kN (5 600 kgf)	
Bucket digging force SAE: PCSA	47 kN (4 800 kgf)	
Arm crowd force ISO	38 kN (3 900 kgf)	32 kN (3 300 kgf)
Arm crowd force SAE: PCSA	36 kN (3 700 kgf)	31 kN (3 200 kgf)

Excluding track shoe lug

# LIFTING CAPACITIES

- Notes: 1. Ratings are based on ISO 10567.  
 2. Lifting capacity of the ZAXIS Series does not exceed 75% of tipping load with the machine on firm, level ground or 87% full hydraulic capacity.  
 3. The load point is the centre-line of the bucket pivot mounting pin on the arm.  
 4. \*Indicates load limited by hydraulic capacity.  
 5. 0 m = Ground.

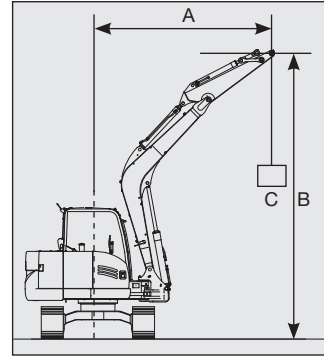

A: Load radius  
 B: Load point height  
 C: Lifting capacity

## ZX85USBLC-3 MONOBLOCK BOOM: Blade (Down)



Rating over-front



Rating over-side or 360 degrees

Unit: kg

Conditions	Load point height	Load radius								At max. reach		
		1.5 m		3.0 m		4.5 m		6.0 m		meter		
Boom 3.67 m Arm 1.62 m Counterweight 1 480 kg Grouser Shoe 450 mm	4.5 m											
	3.0 m			*3 590	3 010					*1 890	1 060	5.89
	1.5 m					*2 840	1 510			*2 020	960	6.15
	0 (Ground)			*2 340	*2 340	*3 050	1 440			*2 080	990	5.96
	-1.5 m			*4 250	2 610	*2 700	1 440			*2 100	1 170	5.25
	-3.0 m											

Conditions	Load point height	Load radius								At max. reach		
		1.5 m		3.0 m		4.5 m		6.0 m		meter		
Boom 3.67 m Arm 2.12 m Counterweight 1 480 kg Grouser Shoe 450 mm	4.5 m					*1 710	*1 710			*1 560	1 160	5.70
	3.0 m					*2 060	1 650	*1 790	1 050	*1 520	940	6.41
	1.5 m					*2 660	1 530	*1 970	1 010	*1 610	860	6.64
	0 (Ground)			*2 460	*2 460	*3 020	1 450	*2 080	970	*1 870	880	6.47
	-1.5 m	*2 670	*2 670	*4 740	2 590	*2 890	1 420			*1 930	1 010	5.83
	-3.0 m			*3 210	2 670	*1 830	1 480			*1 830	1 480	4.50

## ZX85USBLCN-3 MONOBLOCK BOOM: Blade (Down)









Conditions	Load point height	Load radius								At max. reach		
		1.5 m		3.0 m		4.5 m		6.0 m		meter		
Boom 3.67 m Arm 1.62 m Counterweight 1 480 kg Grouser Shoe 450 mm	4.5 m											
	3.0 m			*3 590	2 750					*1 900	980	5.89
	1.5 m				2 330	*2 840	1 380			*2 020	880	6.15
	0 (Ground)			*2 340		*3 050	1 310			*2 080	900	5.96
	-1.5 m			*4 250	2 360	*2 700	1 310			*2 100	1 070	5.25
	-3.0 m											









Conditions	Load point height	Load radius								At max. reach		
		1.5 m		3.0 m		4.5 m		6.0 m		meter		
Boom 3.67 m Arm 2.12 m Counterweight 1 480 kg Grouser Shoe 450 mm	4.5 m					*1 730	1 610			*1 570	1 090	5.70
	3.0 m					*2 080	1 540	*1 820	980	*1 530	880	6.41
	1.5 m					*2 680	1 430	*1 990	940	*1 620	810	6.64
	0 (Ground)			*2 470	2 360	*3 050	1 350	*2 100	910	*1 890	820	6.47
	-1.5 m	*2 680	*2 680	*4 750	2 370	*2 920	1 320			*1 950	940	5.83
	-3.0 m			*3 240	2 440	*1 860	1 370			*1 860	1 370	4.50

**ZX85USBLC-3 2-PIECE BOOM: Blade (Down)**
 Rating over-front









 Rating over-side or 360 degrees









Unit: kg

Conditions	Load point height	Load radius								At max. reach		
		1.5 m		3.0 m		4.5 m		6.0 m		meter		
												
2-Piece Boom Arm 1.62 m Counterweight 1 480 kg Grouser Shoe 450 mm	6.0 m									*2 340	2 140	3.85
	4.5 m									*1 860	1 180	5.46
	3.0 m			*3 950	3 110					*1 790	910	6.20
	1.5 m			*4 680	3 080	*2 830	1 560			*1 810	820	6.45
	0 (Ground)	*4 080	*4 080	*5 330	2 690	*2 920	1 470			*1 760	830	6.27
	-1.5 m	*6 730	*6 730	*5 370	2 560	*2 770	1 350			*1 620	960	5.60

Conditions	Load point height	Load radius								At max. reach		
		1.5 m		3.0 m		4.5 m		6.0 m		meter		
												
2-Piece Boom Arm 2.12 m Counterweight 1 480 kg Grouser Shoe 450 mm	6.0 m					*1 980	1 680			*1 790	1 530	4.72
	4.5 m					*1 880	1 720	*1 650	990	*1 500	970	6.06
	3.0 m			*3 370	3 110	*2 200	1 690	*1 760	1 000	*1 440	770	6.72
	1.5 m	*3 300	*3 300	*4 420	*3 010	*2 650	1 660	*1 880	960	*1 500	700	6.94
	0 (Ground)	*3 320	*3 320	*5 120	2 730	*2 830	1 490	*1 960	880	*1 560	700	6.78
	-1.5 m	*5 530	*5 530	*5 390	2 510	*2 920	1 340	*1 640	830	*1 470	790	6.18
-3.0 m	*6 560	*6 560	*3 770	2 450	*1 680	1 300			*1 340	1 180	4.80	

**ZX85USBLCN-3 2-PIECE BOOM: Blade (Down)**

Conditions	Load point height	Load radius								At max. reach		
		1.5 m		3.0 m		4.5 m		6.0 m		meter		
												
2-Piece Boom Arm 1.62 m Counterweight 1 480 kg Grouser Shoe 450 mm	6.0 m									*2 340	1 960	3.85
	4.5 m									*1 860	1 070	5.46
	3.0 m			*3 950	*2 870					*1 790	820	6.20
	1.5 m			*4 680	2 810	*2 830	1 420			*1 810	740	6.45
	0 (Ground)	*4 080	*4 080	*5 330	2 420	*2 920	1 330			*1 760	740	6.27
	-1.5 m	*6 730	*6 730	*5 370	2 290	*2 770	1 220			*1 620	860	5.60

Conditions	Load point height	Load radius								At max. reach		
		1.5 m		3.0 m		4.5 m		6.0 m		meter		
												
2-Piece Boom Arm 2.12 m Counterweight 1 480 kg Grouser Shoe 450 mm	6.0 m					*1 980	1 530			*1 790	1 390	4.72
	4.5 m					*1 880	1 600	*1 650	900	*1 500	880	6.06
	3.0 m			*3 370	*2 870	*2 200	1 570	*1 760	910	*1 440	690	6.72
	1.5 m	*3 300	*3 300	*4 420	*2 780	*2 650	1 520	*1 880	870	*1 500	620	6.94
	0 (Ground)	*3 320	*3 320	*5 120	*2 450	*2 830	1 350	*1 960	790	*1 560	620	6.78
	-1.5 m	*5 530	*5 530	*5 390	*2 240	*2 920	1 200	*1 640	740	*1 470	700	6.18
-3.0 m	*6 560	*6 560	*3 770	*2 190	*1 680	1 160			*1 340	1 060	4.80	

# EQUIPMENT

## STANDARD EQUIPMENT

Standard equipment may vary by country, so please consult your Hitachi dealer for details.

### ENGINE

- P mode control
- E mode control
- 50 A alternator
- Dry-type air filter with evacuator valve (with Air cleaner restriction switch for monitor)
- Cartridge-type engine oil filter
- Cartridge-type fuel filter
- Air cleaner double filters
- Radiator and oil cooler with dust protective net
- Radiator reserve tank
- Fan guard
- Isolation-mounted engine
- Auto-idle system
- Electrical fuel feed pump with auto stop

### HYDRAULIC SYSTEM

- E-P control system
- Quick warm-up system for pilot circuit
- Shockless valve in pilot circuit
- Boom anti-drift valve
- Control valve with main relief valve
- Extra port for control valve
- Suction filter
- Full-flow filter
- Pilot filter

### CAB

- CRES II (Corner Reinforced Structure) cab
- OPG top guard fitted Level I (ISO 10262) compliant cab
- All-weather sound-suppressed steel cab
- Reinforced, tinted glass windows
- 4 fluid-filled elastic mounts
- Openable upper and lower front and left windows
- Intermittent windshield wipers
- Front window washer
- Footrest
- Wrist rest
- Electric horn
- AM - FM radio with digital clock
- Auto-idle
- Seat belt
- Drink holder
- Cigar lighter
- Ashtray
- Magazine box
- Glove compartment
- Fire extinguisher bracket
- Floor mat
- Pilot control shut-off lever
- Engine stop knob
- Auto control air conditioner
- Transparency roof with roll curtain
- Mechanical suspension seat with heater

### MONITOR SYSTEM

- Meters: Hourmeter and trip-meter, engine coolant temperature gauge and fuel gauge.
- Warning lamps: Alternator charge, engine oil pressure, engine overheat, air filter restriction and minimum fuel level.
- Pilot lamps: Engine preheat, work light, auto-idle
- Alarm buzzers: Engine oil pressure and engine overheat

### LIGHTS

- 2 working lights

### UPPERSTRUCTURE

- Undercover
- 1 480 kg counterweight
- Fuel level float
- Hydraulic oil level gauge
- Rearview mirror (right, left side & cab rear)
- Swing parking brake

### UNDERCARRIAGE

- Travel parking brake
- Travel motor covers
- Hydraulic track adjuster
- Bolt-on sprocket
- Upper rollers and lower rollers
- Reinforced track links with pin seals
- 4 tie down hooks

### FRONT ATTACHMENTS

- HN bushing
- WC (tungsten-carbide) thermal spraying
- Reinforced resin thrust plate
- Flanged pin
- Dirt seal on all bucket pins

### MISCELLANEOUS

- Standard tool kit
- Lockable machine covers
- Lockable fuel filling cap
- Handrails
- Travel direction mark on track frame
- Onboard information controller

## OPTIONAL EQUIPMENT

Optional equipment may vary by country, so please consult your Hitachi dealer for details.

### CAB

- OPG top guard, Level II
- Front glass lower guard
- Front glass upper guard
- Overhead guard
- Laminated round glass window
- Air suspension seat with heater
- Rain guard
- Sun visor
- Additional fuse box
- Immobilizer key
- 12 V power source

### LIGHTS

- Additional cab roof front lights
- Additional cab roof rear lights
- Rotating lamp
- Additional boom light with cover

### UNDERCARRIAGE

- Track undercover
- Dozer blade (Width: 2 200 mm / 2 320 mm / 2 470 mm)

### ATTACHMENT

- Hammer and crusher piping
- 2 pump combined flow
- Assist piping
- Reinforced link B
- Reinforced arm
- Pilot accumulator
- Welded bucket link A with welded hook

### OTHERS

- Hose rupture valves
- Overload warning device
- Fuel double filters
- Rear view camera
- Biodegradable oil

Prior to operating this machine, including satellite communication system, in a country other than a country of its intended use, it may be necessary to make modifications to it so that it complies with the local regulatory standards (including safety standards) and legal requirements of that particular country. Please do not export or operate this machine outside the country of its intended use until such compliance has been confirmed. Please contact your Hitachi dealer in case of questions about compliance.

These specifications are subject to change without notice.

Illustrations and photos show the standard models, and may or may not include optional equipment, accessories, and all standard equipment with some differences in color and features. Before use, read and understand the Operator's Manual for proper operation.