

EX5500

Specifications

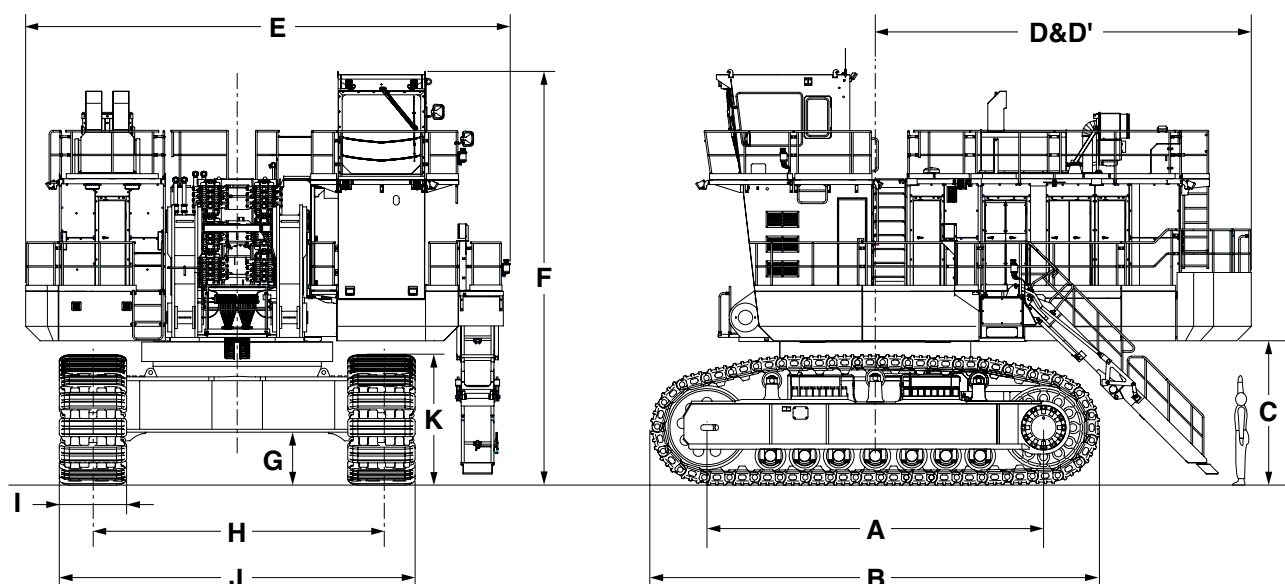

Illustrations show diesel engine type.

A	Distance between tumpers	7 000 mm
B	Undercarriage length	9 350 mm
C	Counterweight clearance	3 000 mm
D	Rear-end swing radius	7 950 mm
D'	Rear-end length	7 820 mm
E	Overall width of upperstructure	10 080 mm
F	Overall height of cab	8 600 mm
G	Min. ground clearance	1 100 mm
H	Track gauge	6 000 mm
I	Track shoe width	1 400 mm
J	Undercarriage width	7 400 mm
K	Track height	2 730 mm

HYDRAULIC EXCAVATOR

■ EX5500-6 with Diesel Engine

Engine Gross Power : 2 x 1 044 kW (2 x 1 400 HP)

Operating Weight : Loading Shovel : 522 000 kg
Backhoe : 522 000 kg

■ EX5500E-6 with Electric Motor

Power Output : 2 x 860 kW

Operating Weight : Loading Shovel : 516 000 kg

■ Bucket Capacity

Loading Shovel Bucket : Heaped : 27.0 m³

Backhoe Bucket : SAE, PCSA Heaped : 29.0 m³ CECE Heaped : 26.0 m³

SPECIFICATIONS

EX5500-6

ENGINE

Model	Cummins QSKTA50-CE
Type	Water-cooled, 4-cycle, 16-cylinder, turbo-charged and after-cooled, direct injection chamber-type diesel engine
Rated power	
SAE J1995, gross	2 x 1 044 kW (2 x 1 400 HP) at 1 800 min ⁻¹ (rpm)
Net	2 x 994 kW (2 x 1 333 HP) at 1 800 min ⁻¹ (rpm)
Maximum torque	2 x 6 379 N·m (2 x 651 kgf·m) at 1 300 min ⁻¹ (rpm)
Piston displacement	2 x 50 L
Bore and stroke	159 mm x 159 mm
Starting system	24 V electric motor
Batteries	6 x 12 V , 6 x 220 AH
Cold starting	Ether aided

HYDRAULIC SYSTEM

Hitachi's ETS (Electronic Total control System) can achieve maximum job efficiency by reducing fuel consumption and noise levels, while maximizing productivity through the optimization of engine-pump functions with excellent controllability increasing operator comfort.

- E-P Control (Computer-aided Engine-Pump Control system)
Main pumps regulated by electric engine speed sensing control system.
- OHS (Optimum Hydraulic System)
12 main pumps and 6 valves system enable both independent and combined operations of all functions.
- FPS (Fuel-saving Pump System)
FPS minimizes energy loss with superior performance in fine control.
- Auto-idling system for saving fuel and reducing noise.
- Hydraulic drive cooling-fan system for oil cooler.
- Forced-lubrication and forced-cooling pump drive system.

Main pumps	8 variable-displacement, axis piston pumps for front attachment and travel
Pressure setting	29.4 MPa (300 kgf/cm ²)
Max. oil flow	8 X 375 L/min
Swing pump	4 variable-displacement, axis piston pumps for swinging
Pressure setting	29.4 MPa (300 kgf/cm ²)
Max. oil flow	4 X 425 L/min
Pilot pump	2 gear pump
Pressure setting	3.9 MPa (40 kgf/cm ²)
Max. oil flow	2 x 108 L/min

Relief Valve Settings

Implement circuit	29.4 MPa (300 kgf/cm ²)
Swing circuit	24.5 MPa (250 kgf/cm ²)
Travel circuit	29.4 MPa (300 kgf/cm ²)
Pilot circuit	3.9 MPa (40 kgf/cm ²)

Hydraulic Cylinders

High-strength piston rods and tubes adopted. Cylinder cushion mechanisms are provided for boom, arm bucket and dump cylinders. Bucket cylinders of loading shovel are provided with protector.

Cylinder Dimensions Loading shovel

	Quan.	Bore	Rod diameter
Boom	2	420 mm	300 mm
Arm	1	360 mm	260 mm
Bucket	2	340 mm	250 mm
Dump	2	280 mm	160 mm
Level	1	420 mm	300 mm

Backhoe

	Quan.	Bore	Rod diameter
BE-boom	2	420 mm	300 mm
BE-arm	1	360 mm	260 mm
Bucket	1	310 mm	230 mm

Hydraulic Filters

All hydraulic circuits have high-quality hydraulic filters for protection against oil contamination and longer life of hydraulic components.

	Qty.	
Full flow filter	6	10 μm
High pressure strainer (In main & swing pump delivery line)	12	80 meshes
Drain filter (For all plunger type pumps & motors)	1	10 μm
By-pass filter (In oil cooler by-pass line)	1	5 μm
Pilot filter	1	10 μm

These filters are centralized in arrangement for facilitating maintenance.

CONTROLS

2 Implement Levers

Electric joystick control levers. Right lever is for boom and bucket control, left lever for swing and arm control. For loading shovel, 2 pedals provided for opening/closing the bottom dump bucket.

2 Travel Levers with Pedals

Remote-controlled hydraulic servo system. Independent drive at each track allows counter rotation of tracks.

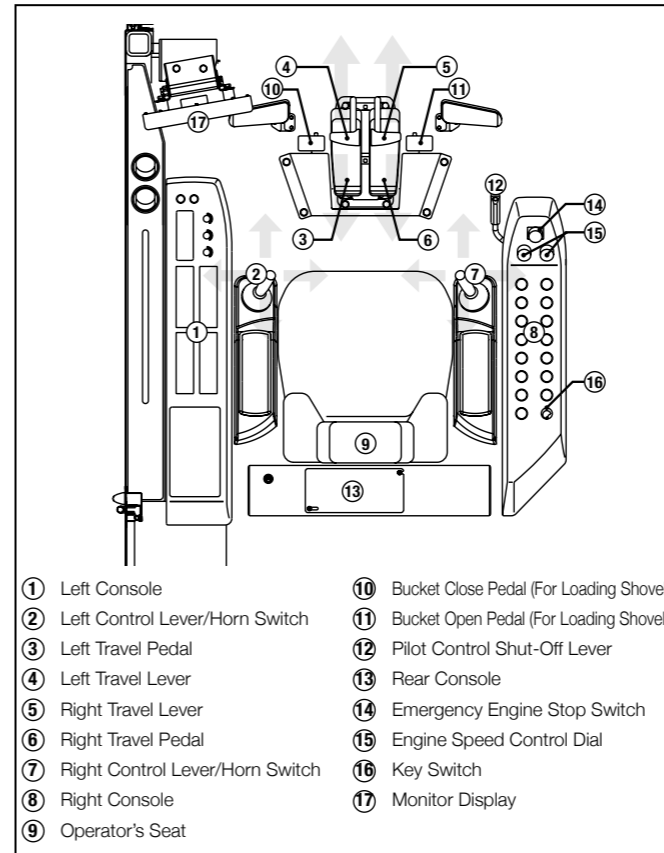

- | | |
|-----------------------------------|---|
| ① Left Console | ⑩ Bucket Close Pedal (For Loading Shovel) |
| ② Left Control Lever/Horn Switch | ⑪ Bucket Open Pedal (For Loading Shovel) |
| ③ Left Travel Pedal | ⑫ Pilot Control Shut-Off Lever |
| ④ Left Travel Lever | ⑬ Rear Console |
| ⑤ Right Travel Lever | ⑭ Emergency Engine Stop Switch |
| ⑥ Right Travel Pedal | ⑮ Engine Speed Control Dial |
| ⑦ Right Control Lever/Horn Switch | ⑯ Key Switch |
| ⑧ Right Console | ⑰ Monitor Display |
| ⑨ Operator's Seat | |

UPPERSTRUCTURE

Revolving Frame

A deep, full-reinforced box section. Heavy-gauge steel plates used for ruggedness.

Deck Machinery

Maintenance accessibility is the major feature in the layout of deck machinery. Sidewalks provide easy access to engines, hydraulic and electrical components. ISO-met stairs and handrails. Sidewalks and stairs are provided with skid-resistant plates.

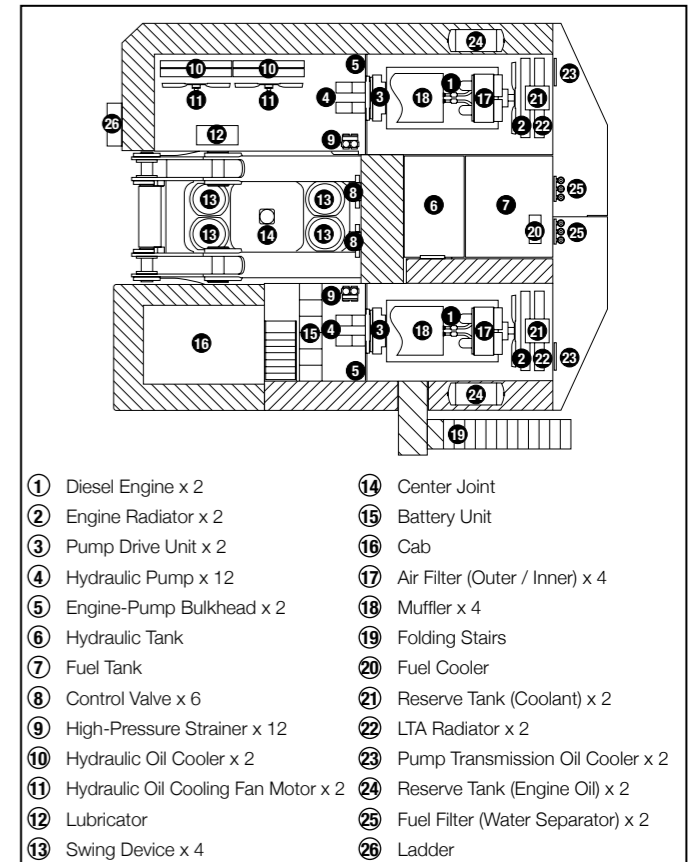

- | | |
|---------------------------------------|-------------------------------------|
| ① Diesel Engine x 2 | ⑭ Center Joint |
| ② Engine Radiator x 2 | ⑮ Battery Unit |
| ③ Pump Drive Unit x 2 | ⑯ Cab |
| ④ Hydraulic Pump x 12 | ⑰ Air Filter (Outer / Inner) x 4 |
| ⑤ Engine-Pump Bulkhead x 2 | ⑱ Muffler x 4 |
| ⑥ Hydraulic Tank | ⑲ Folding Stairs |
| ⑦ Fuel Tank | ⑳ Fuel Cooler |
| ⑧ Control Valve x 6 | ㉑ Reserve Tank (Coolant) x 2 |
| ⑨ High-Pressure Strainer x 12 | ㉒ LTA Radiator x 2 |
| ⑩ Hydraulic Oil Cooler x 2 | ㉓ Pump Transmission Oil Cooler x 2 |
| ⑪ Hydraulic Oil Cooling Fan Motor x 2 | ㉔ Reserve Tank (Engine Oil) x 2 |
| ⑫ Lubricator | ㉕ Fuel Filter (Water Separator) x 2 |
| ⑬ Swing Device x 4 | ㉖ Ladder |

Swing Mechanism

4 high-torque, axial-piston motors with two-stage planetary gear bathed in oil. Swing circle with dirt seals is a heavy-duty, triple-row, cylindrical roller bearing. Induction-hardened internal swing circle gear and pinion immersed in lubricant. Parking brake of spring-set/hydraulic-released disc type. This parking brake is manually releasable.

Swing speed 3.3 min⁻¹ (rpm)

Operator's Cab

The sturdy cab, with the top guard conforming to OPG Level II (ISO), helps protect the operator from falling objects. Independent, pressurized, 1 800 mm wide, 2 150 mm high, roomy 7.5 m³ cab with tinted-glass windows features all-round visibility. Air-suspension type, fully adjustable reclining seat with armrests; movable with or without front & swing control levers by slide. Instruments and control panel are within easy reach of the operator. 3 air conditioner system.

Noise level 75 dB(A) in the cab; on max. engine speed under no-load condition

Eye level height 7 640 mm

SPECIFICATIONS

EX5500-6

UNDERCARRIAGE

Tracks

Shovel-type undercarriage. Dual-flanged-type bolt linkage for side frame and X-form center frame assures durability. Heavy-duty track frame of all-welded, stress-relieved structure. Top-grade materials used for toughness. Lifetime-lubricated induction-hardened track rollers, idlers and drive tumbler with floating seals. Specially heat-treated connection pins. Hydraulic track adjuster provided with N₂ gas accumulator with relief valve. Track adjuster provided with protection device against abnormal tension. Travel motion alarm device.

Shovel-type Undercarriage

Triple grouser track shoes of induction-hardened cast steel.
Shoe width 1 400 mm

Numbers of Rollers and Shoes (each Side)

Upper rollers 3
Lower rollers 7
Track shoes 39

Traction Device

Each track driven by high-torque, axial piston motors, allowing counter rotation of tracks. 2-stage planetary gear plus spur gears reduction device. Dual-support-type traction device. Parking brake of spring-set/hydraulic-released disc type. This parking brake is manually releasable.

Travel speeds High : 0 to 2.3 km/h
Low : 0 to 1.6 km/h

Maximum traction force 2 230 kN
(227 000 kgf)

Grade ability 30°(60 %) continuous

WEIGHTS AND GROUND PRESSURE

Loading Shovel

Equipped with 27.0 m³ (heaped) bottom dump bucket

Shoe type	Shoe width	Operating weight	Ground pressure
Triple grousers	1 400 mm	522 000 kg	232 kPa (2.37 kgf/cm ²)

Backhoe

Equipped with 10.6 m BE-boom, 5.3 m BE-arm, and 29.0 m³ (SAE, PCSA heaped) bucket

Shoe type	Shoe width	Operating weight	Ground pressure
Triple grousers	1 400 mm	522 000 kg	232 kPa (2.37 kgf/cm ²)

SERVICE REFILL CAPACITIES

		liters
Fuel tank		11 300
Engine coolant		2 x 476
Engine oil	Engine oil pan	2 x 150
	Reserve tank	2 x 205
Pump drive		2 x 28
Swing drive device (4 units)		4 x 84
Travel drive device (2 units)		2 x 340
Hydraulic system		6 200
Hydraulic tank		2 200

LOADING SHOVEL ATTACHMENTS

Boom and arm are of all-welded, low-stress, high-tensile strength steel full-box section design. Efficient, automatic level crowding achieved by one-lever control as the parallel link mechanism keeps the bucket digging angle constant, and level cylinder circuit maintains the bucket height constant (Auto-Leveling Crowd Mechanism).

Bucket

Capacity (heaped)	Width	No. of teeth	Weight	Type
27.0 m ³	4 700 mm	6	43 300 kg	Boom dump type general purpose

WORKING RANGES

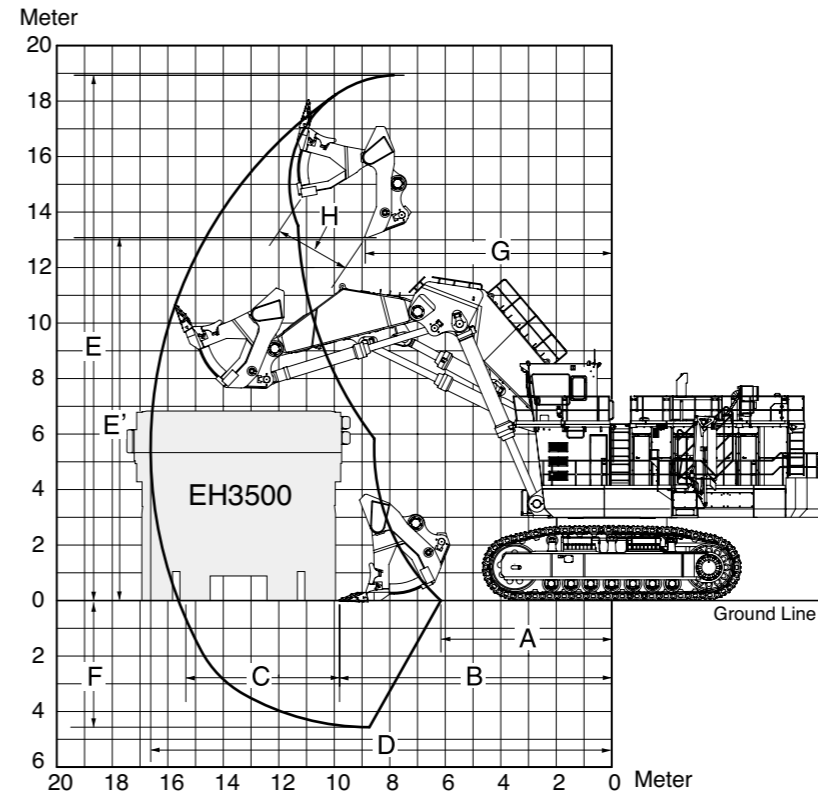

Unit: mm

A	Min. digging distance	6 150
B	Min. level crowding distance	9 800
C	Level crowding distance	5 550
D	Max. digging reach	16 600
E	Max. cutting height	18 900
E'	Max. dumping height	13 100
F	Max. digging depth	4 550
G	Working radius at max. dumping height	8 900
H	Max. bucket opening width	2 700
Arm crowding force		1 570 kN (160 000 kgf)
Breakout force		1 570 kN (160 000 kgf)

SPECIFICATIONS

EX5500-6

BACKHOE ATTACHMENTS

Boom and arm are of all-welded, low-stress, full-box section design.
Bucket of all-welded, high-strength steel structure.

Bucket

Capacity		Width		No. of teeth	Weight	Type
SAE, PCSA heaped	CECE heaped	With side cutters	Without side cutters			
29.0 m ³	26.0 m ³	4 150 mm	-	5	29 200 kg	general purpose

WORKING RANGES

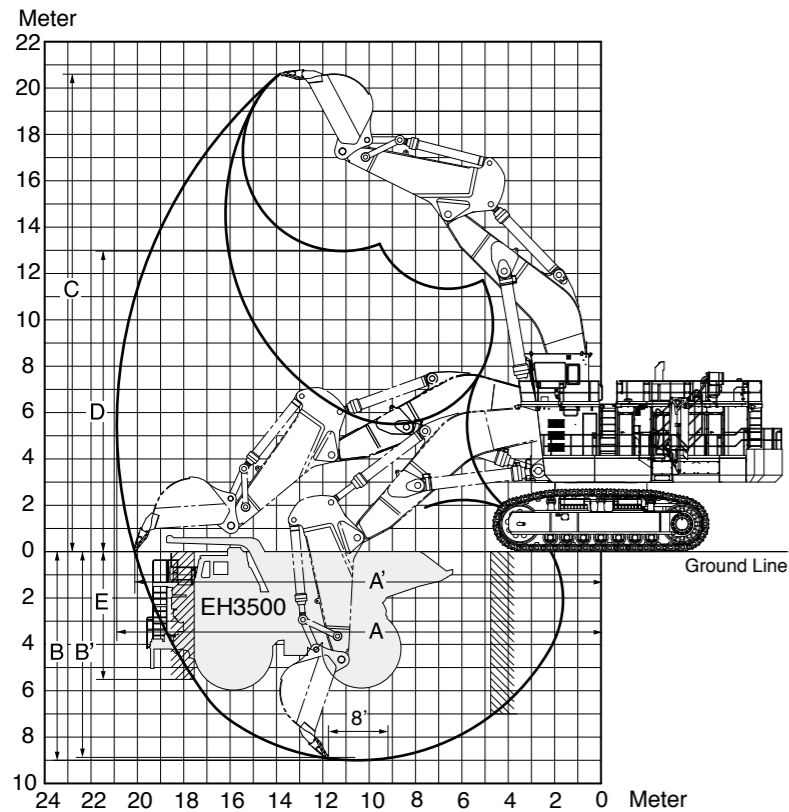

Unit: mm

BE-boom length		10.6 m
BE-arm length		5.3 m
A	Max. digging reach	20 900
A'	Max. digging reach (on ground)	20 100
B	Max. digging depth	9 000
B'	Max. digging depth (8' level)	8 900
C	Max. cutting height	20 600
D	Max. dumping height	13 000
E	Max. vertical wall	5 500
Bucket digging force	ISO	1 370 kN (140 000 kgf)
	SAE, PCSA	1 310 kN (134 000 kgf)
Arm crowd force	ISO	1 240 kN (126 000 kgf)
	SAE, PCSA	1 230 kN (125 000 kgf)

EQUIPMENT

STANDARD EQUIPMENT

Standard equipment may vary by country, so please consult your Hitachi dealer for details.

ENGINE

- 140 A alternator
- Heavy-duty type air cleaner with dust ejector
- Cartridge-type engine oil filter
- Cartridge-type engine oil bypass filter
- Cartridge-type fuel filter
- Water filter
- Radiator reserve tank
- Fan guard
- Isolation-mounted engine
- PRELUB system
- Auto-idle system
- Emergency engine stop system

HYDRAULIC SYSTEM

- E-P control system
- OHS (Optimum Hydraulic System)
- FPS (Fuel-saving Pump System)
- Hydraulic drive cooling-fan system
- Forced-lubrication and forced-cooling pump drive system
- Control valve with main relief valve
- Suction filter
- Full-flow filter
- Bypass filter
- Pilot filter
- Drain filter
- High-pressure strainer

CAB

The sturdy cab, with the top guard conforming to OPG Level II (ISO), helps protect the operator from falling objects. Fluid-filled elastic mounts. Laminated glass windshield. Reinforced/tinted (bronze color) glass side and rear windows. Parallel-link-type intermittent windshield wiper. Front windshield washer. Adjustable reclining seat with air suspension. Footrest. Air horn with electric compressor. Auto-tuning AM-FM radio with digital clock. Seat belt. Storage spaces. Floor mat. Air conditioner with defroster. Rearview mirror. Evacuation hammer. Emergency escape device. Trainer's seat. Pilot control shut-off lever.

MONITOR SYSTEMS

- Meters:
 - Hour meter. Fuel gauge. Hydraulic oil temperature gauge. Engine coolant temperature gauge. Tachometer. Engine oil pressure gauge. Engine oil temperature gauge.
 - Battery voltage gauge. Ambient temperature.
- Pilot lamps (Green):
 - Pre-lub. Auto-Idle. Travel Mode.
- Warning lamps (Red):
 - Alternator. Engine stop. Coolant overheat. Hydraulic oil level. Auto-Lubrication. Fast-filling. Tension. Electric lever. Emergency engine stop. Top valve. Engine over run. Coolant level. Engine oil pressure. Pump transmission oil level indicator.

- Warning lamp (Yellow):
 - Exhaust temperature. Fuel temperature. Engine warning. Hydraulic oil overheat. Stairway position. Electrical equipment box. Pump contamination. Air cleaner restriction.

- Alarm buzzers:
 - Overheat. Engine coolant pressure. Engine coolant level. Fuel temperature. Engine oil pressure. Engine oil temperature. Air intake manifold temperature. Crank case pressure. Pump transmission oil level. Hydraulic oil level. Stop valve close. Fast-fill system panel position (option) Ladder position. Electric lever fault.

DATA LOGGING SYSTEM

- DLU (Data-logging unit) continuously records performance of the engine and the hydraulic system. The record can be downloaded by PC and PDA.

LIGHTS

- 8 working lights. 3 entrance lights. 8 maintenance room lights. 2 cab lights.

UPPERSTRUCTURE

- Lockable machine covers
- 48 700 kg counterweight
- Hydraulic drive grease gun with hose reel
- Folding stairs with wide steps
- Swing parking brake

UNDERCARRIAGE

- Travel parking brake
- Travel motion alarm device
- Travel motor guard. (Backhoe only)
- Hydraulic track adjuster with N₂ gas accumulator with relief valve
- 1 400 mm triple grouser shoes

MISCELLANEOUS

- Standard tool kit
- Stairs and handrails (Meeting ISO)
- Recirculation air filter for air conditioner
- Ventilation air filter for air conditioner
- 12 V power terminal board
- Stop valve for transport and reassembly
- Auto-lubrication system (Lincoln)

FAST-FILLING SYSTEM

- Fast-filling system (Wiggins) for fuel, hydraulic oil, coolant, swing device oil, pump mission oil, engine oil, and grease (couplers not included)

OPTIONAL EQUIPMENT

Optional equipment may vary by country, so please consult your Hitachi dealer for details.

- Electric crane (24 V DC).
- High brightness working lights.
- Back and right side color monitor camera.
- Travel motor guard.
- Travel device guard.

- Fast-Filling couplers.
- Satellite data transmitting system.

SPECIFICATIONS

EX5500E-6

ELECTRIC MOTOR

High Voltage, Three Phase, Squirrel Cage Induction Motor, Totally Enclosed Air-to-Air-Cooled (TEAAC).

Type	HITACHI TFOA-KK
Rating	
Rated continuous output	860 kW x 2
Voltage	AC 6 000 - 6 600 V / 50 Hz AC 6 600 - 6 900 V / 60 Hz
Number of poles	4
Synchronous RPM	1 500 min ⁻¹ / 50 Hz 1 800 min ⁻¹ / 60 Hz
Rated current	89 A x 2 @6 600 V
Insulation class	F class B raise
Space heater included.	
Thermo-guard (temperature detector)	
Starting condition	Reactor 50 % tap

HYDRAULIC SYSTEM

- OHS (Optimum Hydraulic System)
12 main pumps and 6 valves system enable both independent and combined operations of all functions.
- Hydraulic drive cooling-fan system for oil cooler.
- Forced-lubrication and forced-cooling pump drive system.

Main pumps	8 variable-displacement, axis piston pumps for front attachment and travel
Pressure setting	29.4 MPa (300 kgf/cm ²)
Max. oil flow	8 X 375 L/min
Swing pump	4 variable-displacement, axis piston pumps for swinging
Pressure setting	29.4 MPa (300 kgf/cm ²)
Max. oil flow	4 X 425 L/min
Pilot pump	2 gear pump
Pressure setting	3.9 MPa (40 kgf/cm ²)
Max. oil flow	2 x 108 L/min

Relief Valve Settings

Implement circuit	29.4 MPa (300 kgf/cm ²)
Swing circuit	24.5 MPa (250 kgf/cm ²)
Travel circuit	29.4 MPa (300 kgf/cm ²)
Pilot circuit	3.9 MPa (40 kgf/cm ²)

Hydraulic Cylinders

High-strength piston rods and tubes adopted. Cylinder cushion mechanisms are provided for boom, arm bucket and dump cylinders. Bucket cylinder of loading shovel is provided with protector.

Cylinder Dimensions Loading shovel

	Quan.	Bore	Rod diameter
Boom	2	420 mm	300 mm
Arm	1	360 mm	260 mm
Bucket	2	340 mm	250 mm
Dump	2	280 mm	160 mm
Level	1	420 mm	300 mm

Hydraulic Filters

All hydraulic circuits have high-quality hydraulic filters for protection against oil contamination and longer life of hydraulic components.

	Qty.	
Full flow filter	6	10 μm
High pressure strainer (In main & swing pump delivery line)	12	80 meshes
Drain filter (For all plunger type pumps & motors)	1	10 μm
By-pass filter (In oil cooler by-pass line)	1	5 μm
Pilot filter	1	10 μm

These filters are centralized in arrangement for facilitating maintenance.

CONTROLS

2 Implement Levers

Electric joystick control levers. Right lever is for boom and bucket control, left lever for swing and arm control. For loading shovel, 2 pedals provided for opening/closing the bottom dump bucket.

2 Travel Levers with Pedals

Remote-controlled hydraulic servo system. Independent drive at each track allows counter rotation of tracks.

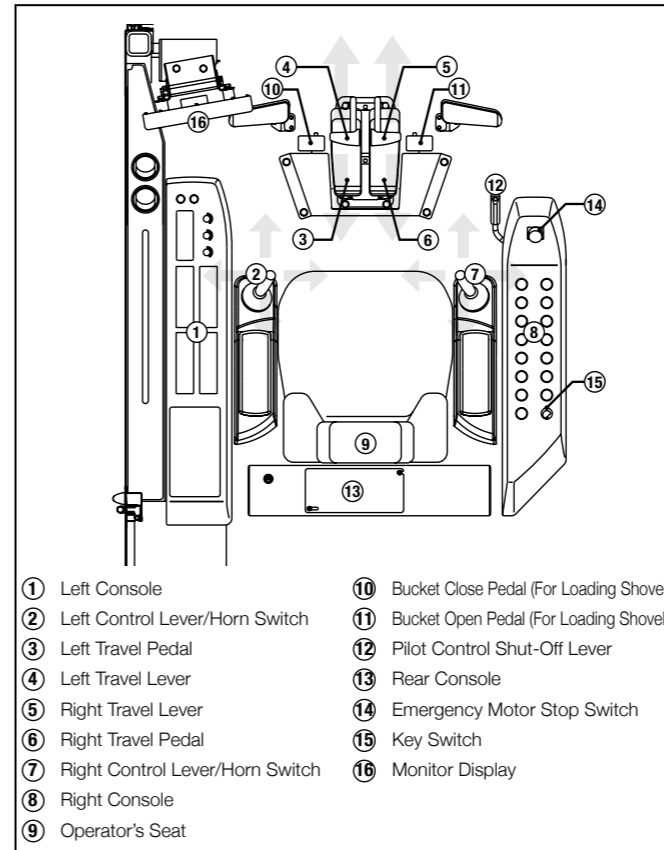

UPPERSTRUCTURE

Revolving Frame

A deep, full-reinforced box section. Heavy-gauge steel plates used for ruggedness.

Deck Machinery

Maintenance accessibility is the major feature in the layout of deck machinery. Sidewalks provide easy access to motors, hydraulic and electrical components. ISO-met stairs and handrails. Sidewalks and stairs are provided with skid-resistant plates.

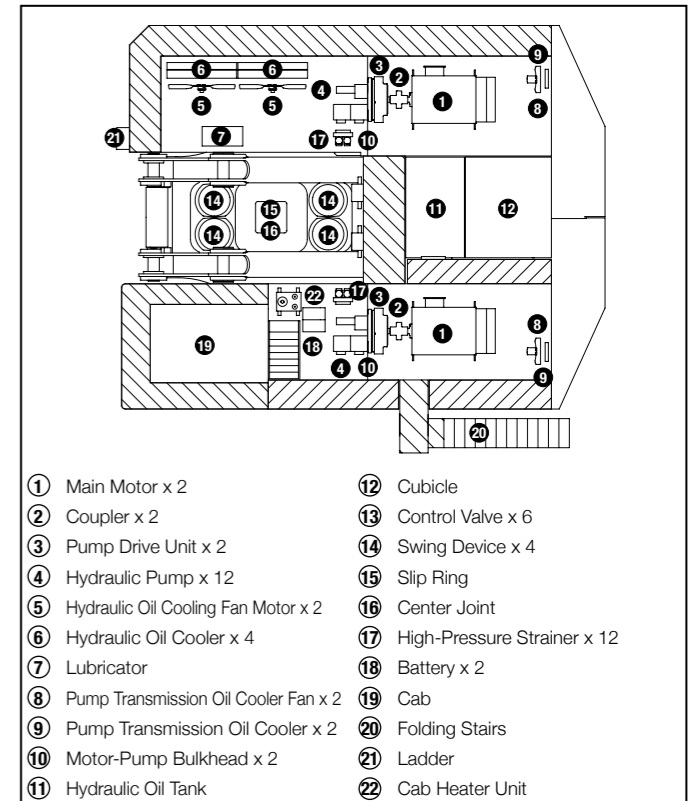

Swing Mechanism

4 high-torque, axial-piston motors with two-stage planetary gear bathed in oil. Swing circle with dirt seals is a heavy-duty, triple-row, cylindrical roller bearing. Induction-hardened internal swing circle gear and pinion immersed in lubricant. Parking brake of spring-set/hydraulic-released disc type. This parking brake is manually releasable.

Swing speed 3.0 min⁻¹ (rpm)

Operator's Cab

The sturdy cab, with the top guard conforming to OPG Level II (ISO), helps protect the operator from falling objects. Independent, pressurized, 1 800 mm wide, 2 150 mm high, roomy 7.5 m³ cab with tinted-glass windows features all-round visibility. Air-suspension type, fully adjustable reclining seat with armrests; movable with or without front & swing control levers by slide. Instruments and control panel are within easy reach of the operator. 3 air conditioner system.

Eye level height 7 640 mm

SPECIFICATIONS

EX5500E-6

UNDERCARRIAGE

Tracks

Shovel-type undercarriage. Dual-flanged-type bolt linkage for side frame and X-form center frame assures durability. Heavy-duty track frame of all-welded, stress-relieved structure. Top-grade materials used for toughness. Lifetime-lubricated induction-hardened track rollers, idlers and drive tumblers with floating seals. Specially heat-treated connection pins. Hydraulic track adjuster provided with N₂ gas accumulator with relief valve. Track adjuster provided with protection device against abnormal tension. Travel motion alarm device.

Shovel-type Undercarriage

Triple grouser track shoes of induction-hardened cast steel.
Shoe width 1 400 mm

Numbers of Rollers and Shoes (each Side)

Upper rollers 3
Lower rollers 7
Track shoes 39

Traction Device

Each track driven by high-torque, axial piston motors, allowing counter rotation of tracks. 2-stage planetary gear plus spur gears reduction device. Dual-support-type traction device. Parking brake of spring-set/hydraulic-released disc type. This parking brake is manually releasable.

Travel speeds High : 0 to 2.1 km/h
Low : 0 to 1.5 km/h

Maximum traction force 2 230 kN
(227 000 kgf)

Grade ability 30°(60 %) continuous

WEIGHTS AND GROUND PRESSURE

Loading Shovel

Equipped with 27.0 m³ (heaped) bottom dump bucket

Shoe type	Shoe width	Operating weight	Ground pressure
Triple grousers	1 400 mm	516 000 kg	229 kPa (2.34 kgf/cm ²)

SERVICE REFILL CAPACITIES

	liters
Pump drive	2 x 28
Swing drive device (4 units)	4 x 84
Travel drive device (2 units)	2 x 340
Hydraulic system	6 200
Hydraulic tank	2 200

LOADING SHOVEL ATTACHMENTS

Boom and arm are of all-welded, low-stress, high-tensile strength steel full-box section design. Efficient, automatic level crowding achieved by one-lever control as the parallel link mechanism keeps the bucket digging angle constant, and level cylinder circuit maintains the bucket height constant (Auto-Leveling Crowd Mechanism).

Bucket

Capacity (heaped)	Width	No. of teeth	Weight	Type
27.0 m ³	4 700 mm	6	43 300 kg	Boom dump type general purpose

WORKING RANGES

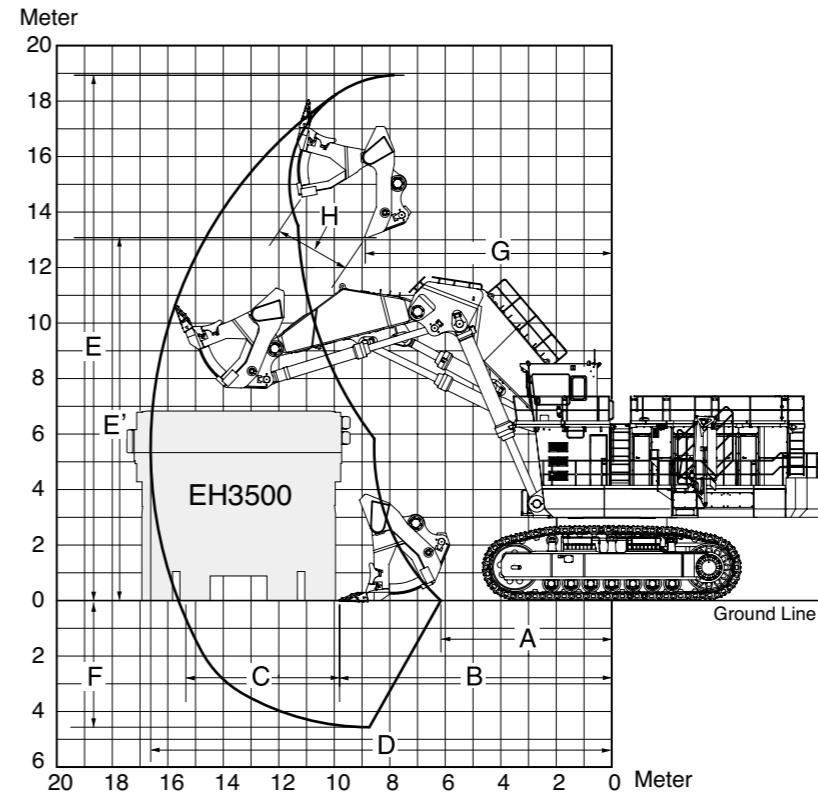

Unit: mm

A	Min. digging distance	6 150
B	Min. level crowding distance	9 800
C	Level crowding distance	5 550
D	Max. digging reach	16 600
E	Max. cutting height	18 900
E'	Max. dumping height	13 100
F	Max. digging depth	4 550
G	Working radius at max. dumping height	8 900
H	Max. bucket opening width	2 700
Arm crowding force		1 570 kN (160 000 kgf)
Breakout force		1 570 kN (160 000 kgf)

TRANSPORTATION

Illustrations show diesel engine type.

- Easily assembled owing to local assembling system requiring no welding.

UPPERSTRUCTURE

Unit: mm

Cab
Weight : 1 750 kg

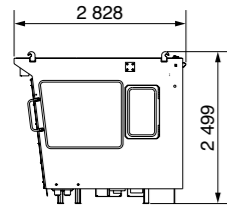

Width : 1 876

Main frame assembly
Weight : 48 300 kg

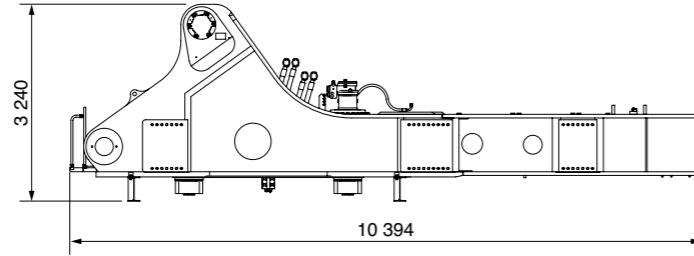

Width : 3 500

Box
Weight : 953 kg

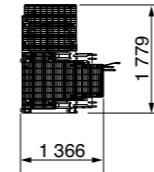

Width : 2 001

Step
Weight : 75 kg

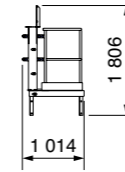

Width : 808

Counterweight (left)
Weight : 24 400 kg

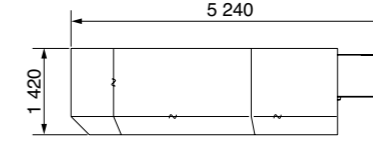

Width : 1 543

Counterweight (right)
Weight : 23 800 kg



Width : 1 543

Unit: mm

Valve assembly
Weight : 7 540 kg

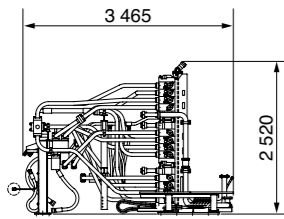

Width : 3 090

Hydraulic oil tank
Weight : 6 730 kg

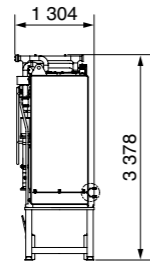

Width : 2 310

Fuel tank
Weight : 5 210 kg

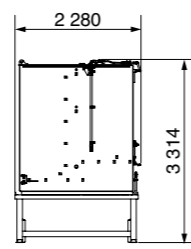

Width : 2 400

Handrail
Weight : 20 kg

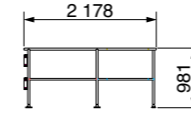

Width : 500

Handrail
Weight : 25 kg

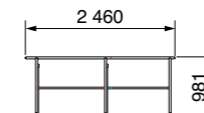

Width : 392

Handrail
Weight : 25 kg

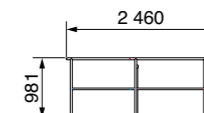

Width : 392

Handrail
Weight : 20 kg

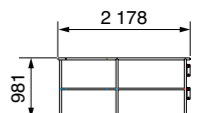

Width : 500

Engine unit (left)
Weight : 26 500 kg

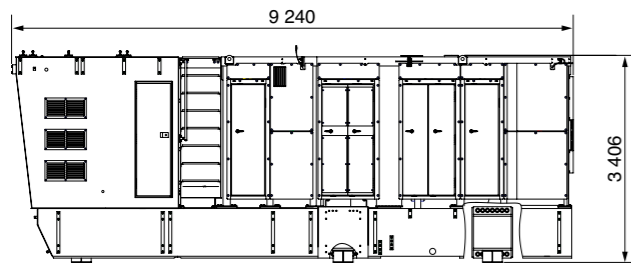

Width : 2 595

Engine unit (right)
Weight : 27 300 kg

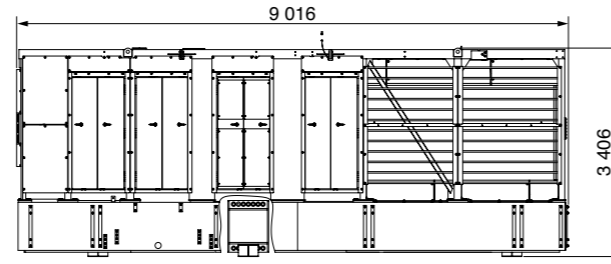

Width : 2 395

Cover
Weight : 18 kg

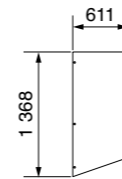

Width : 30

Cover
Weight : 18 kg

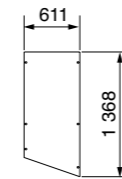

Width : 30

Cover
Weight : 11 kg

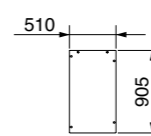

Width : 30

Cover
Weight : 5 kg

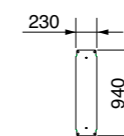

Width : 30

Cover
Weight : 5 kg

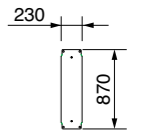

Width : 30

Mufflers and air cleaners (left / right)
Weight : 871 kg x 2

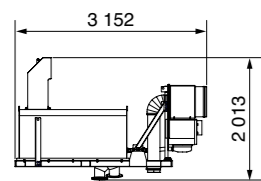

Width : 1 352

Fuel cooler unit
Weight : 53 kg

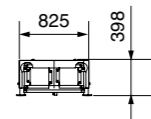

Width : 402

Water Tanks (left / right)
Weight : 177 kg x 2

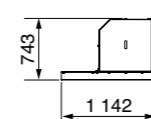

Width : 735

Ladder
Weight : 846 kg

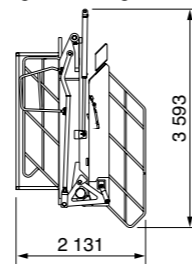

Width : 1 100

Reserve tanks (left / right)
Weight : 370 kg x 2

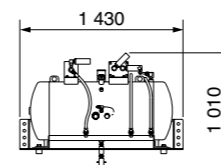

Width : 508

Hydraulic oil pump assembly
Weight : 54 kg

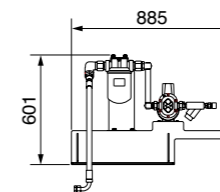

Width : 635

Step
Weight : 21 kg

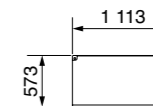

Width : 36

Step
Weight : 19 kg

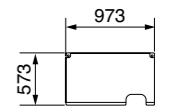

Width : 136

TRANSPORTATION

UPPERSTRUCTURE

Unit: mm

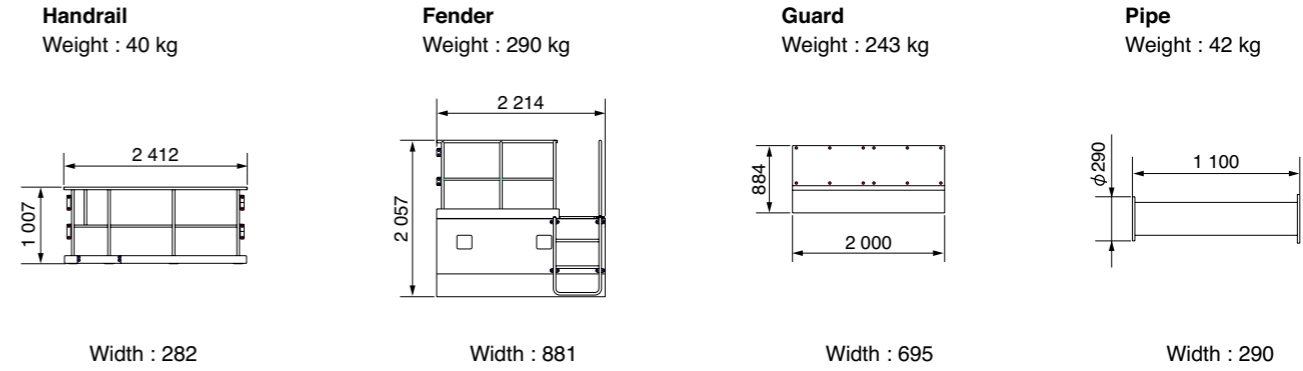
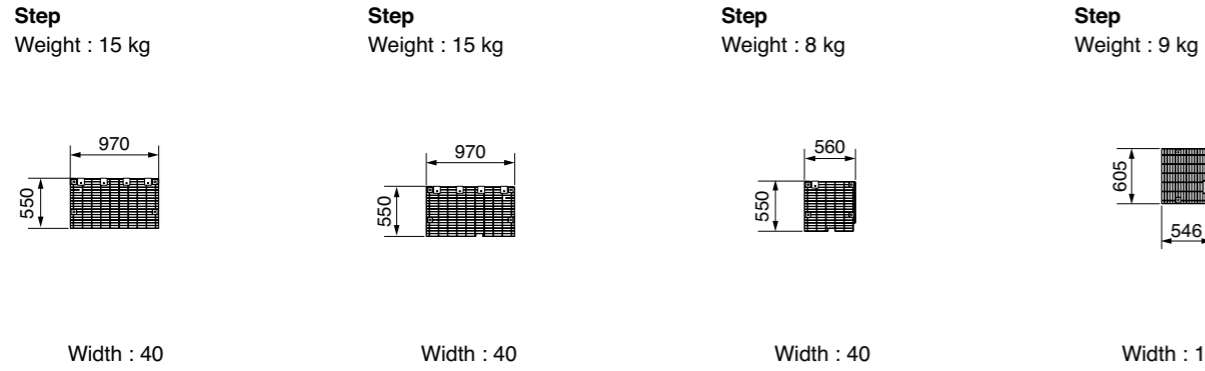

Unit: mm

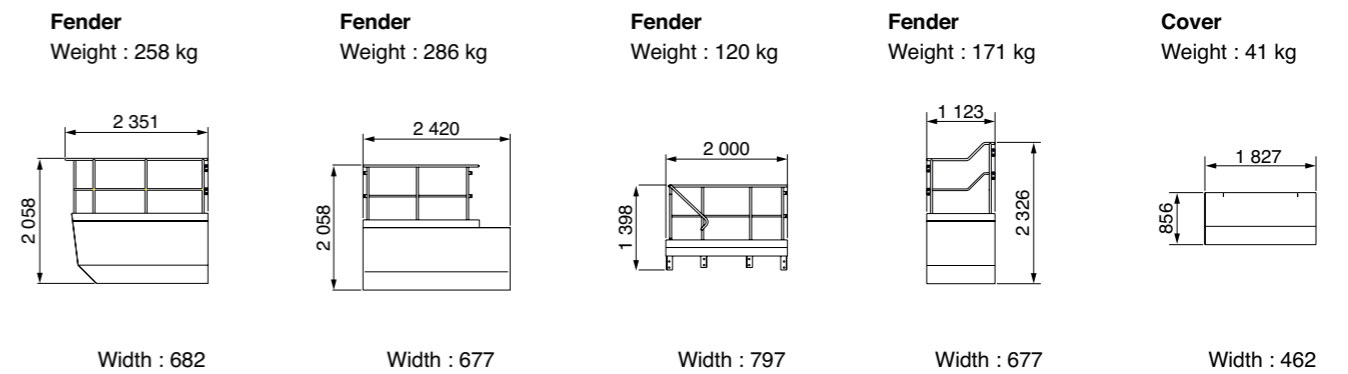
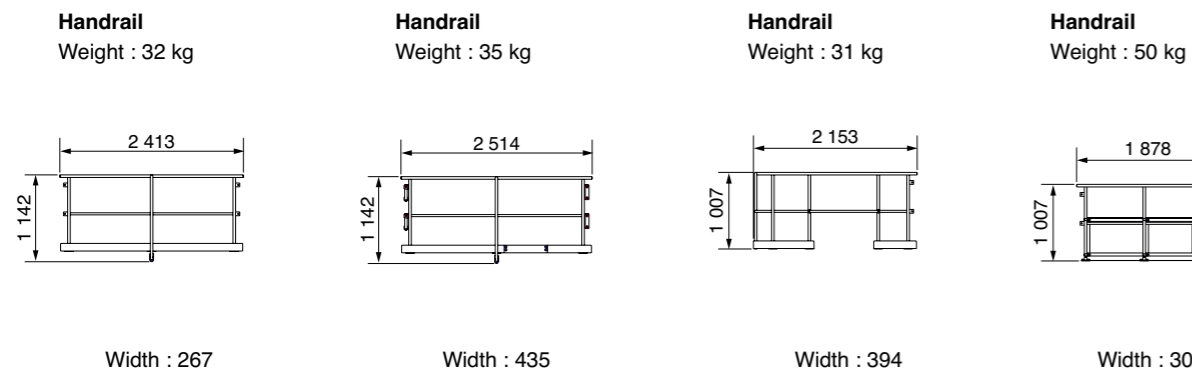
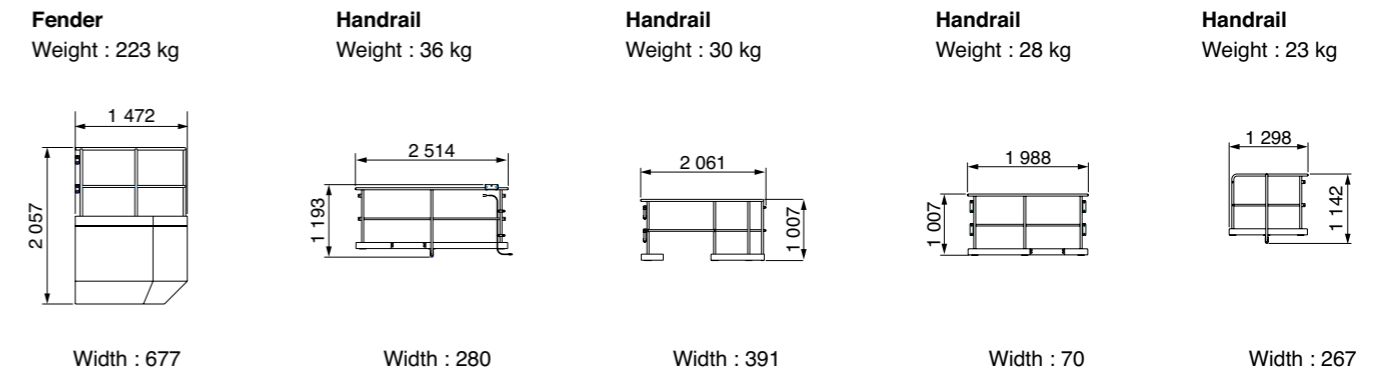
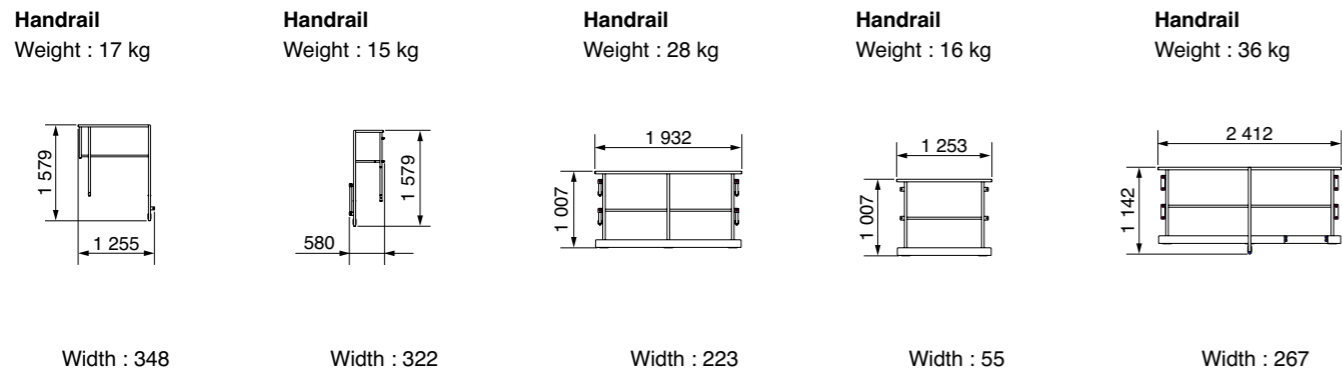
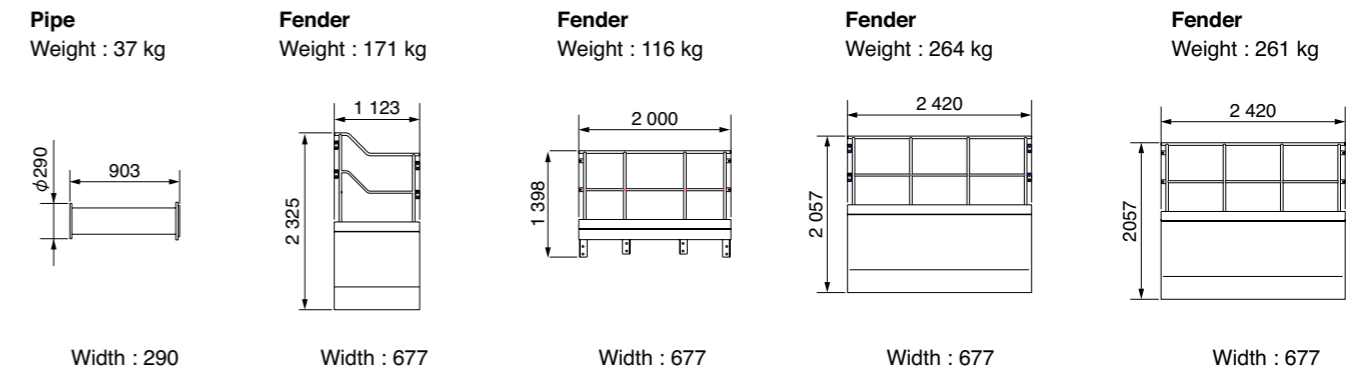
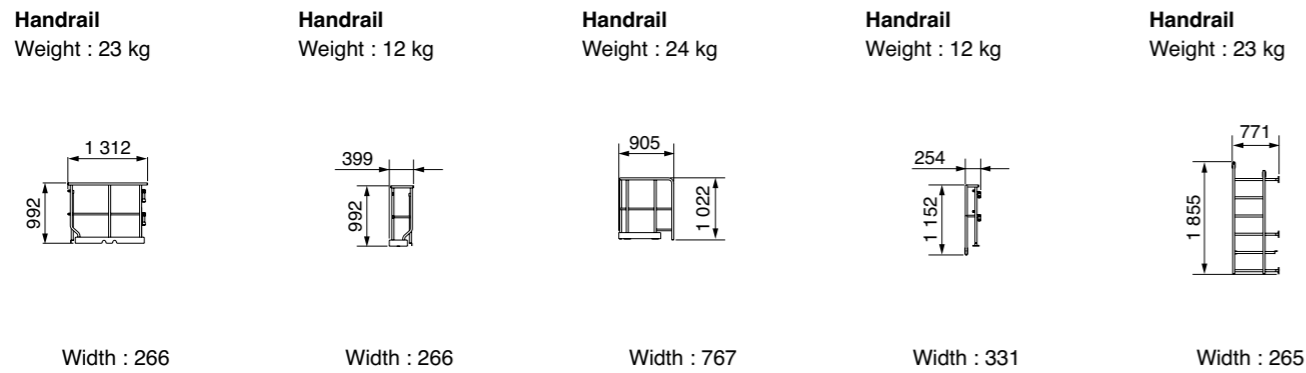

TRANSPORTATION

UPPERSTRUCTURE

Unit: mm

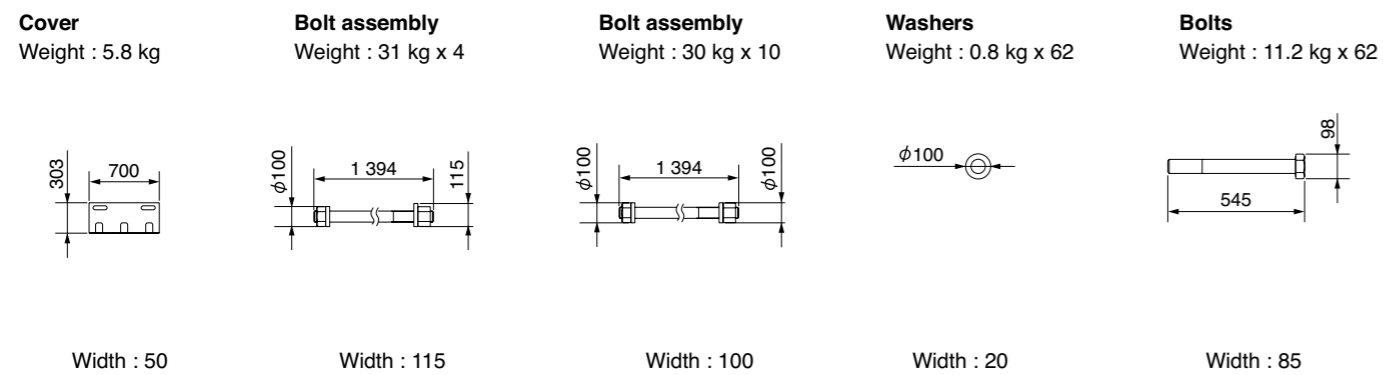
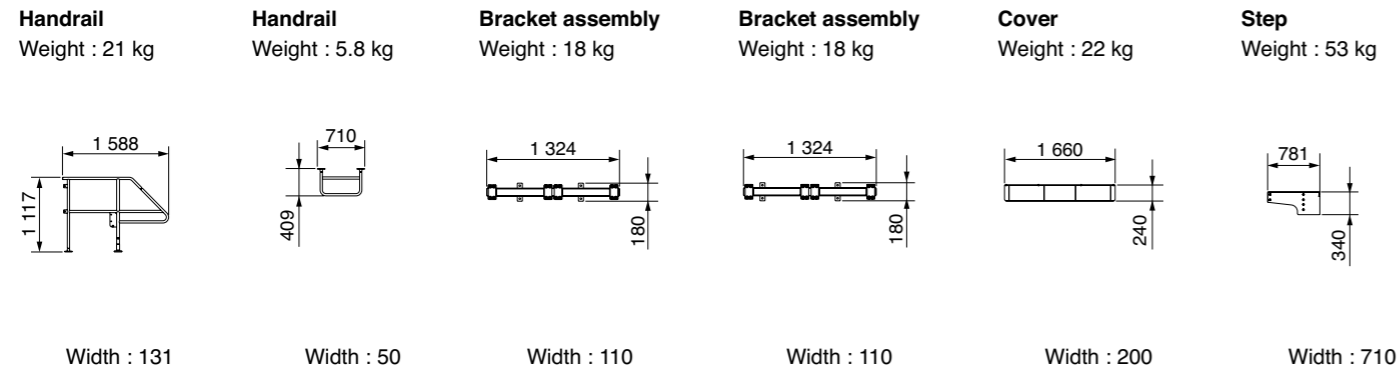
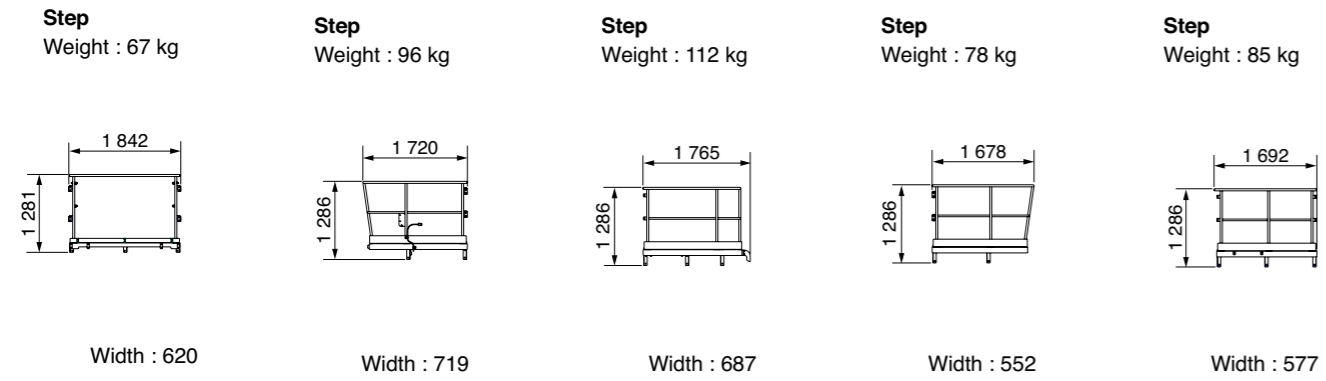
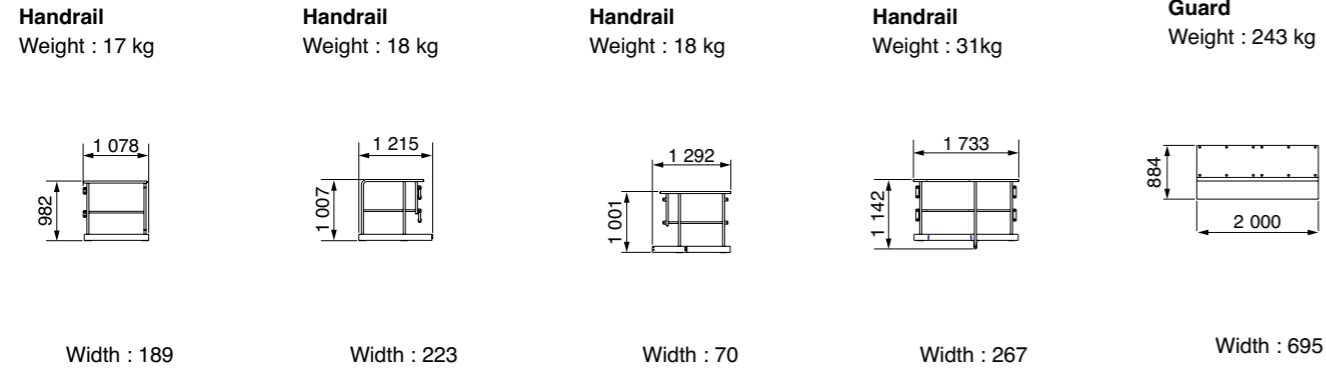

UNDERCARRIAGE

Unit: mm

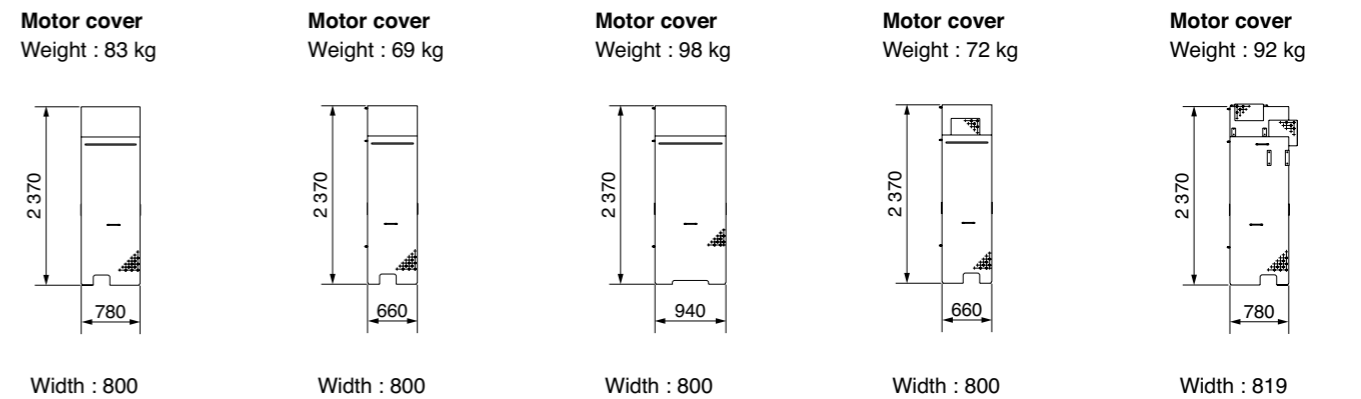
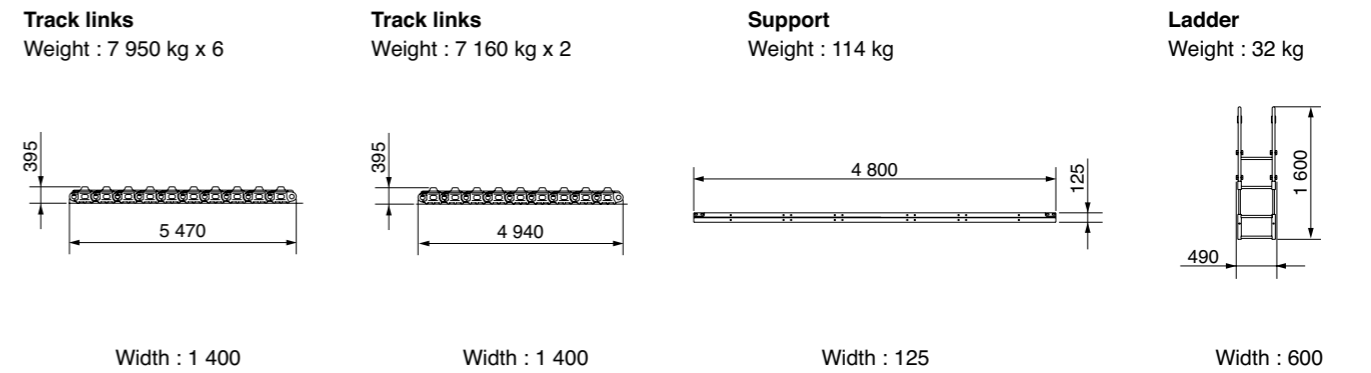
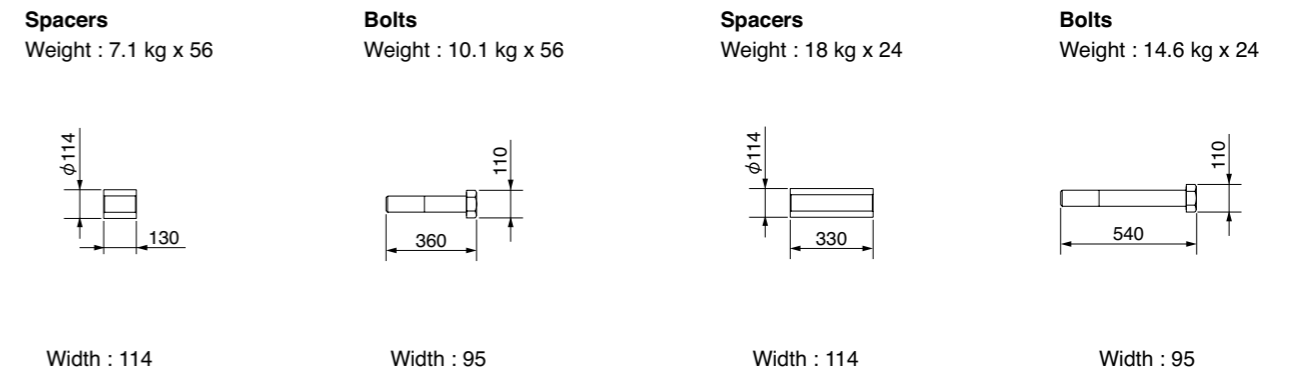
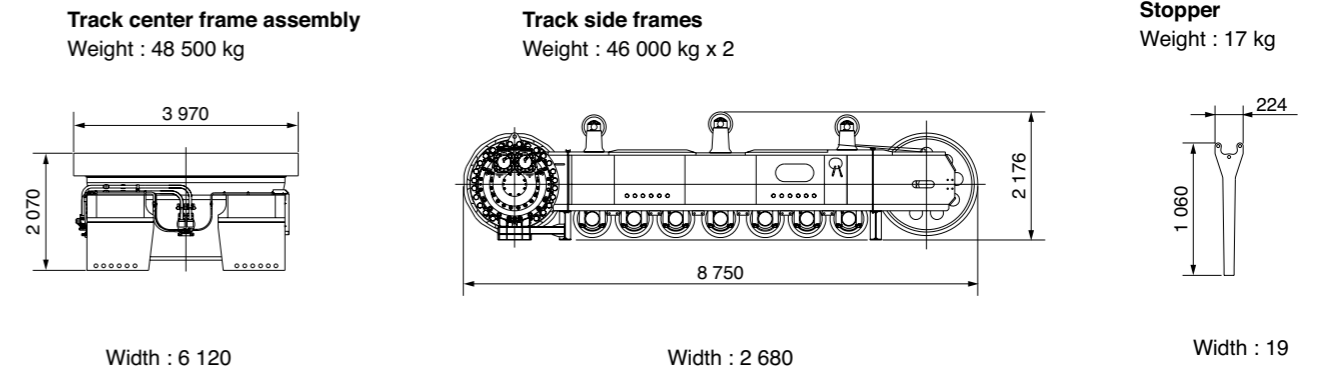

TRANSPORTATION

BACKHOE ATTACHMENTS

Unit: mm

Bucket assembly
Capacity ; 29.0 m³ (SAE, PCSA heaped)
Weight : 30 700 kg

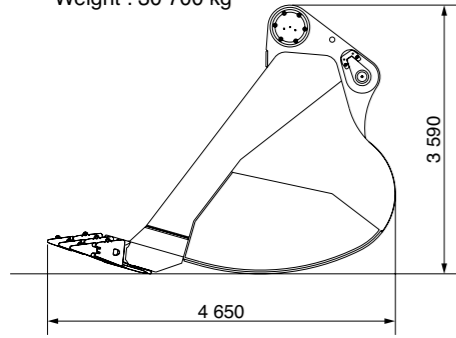

Width : 4 260

Arm assembly
Weight : 37 000 kg

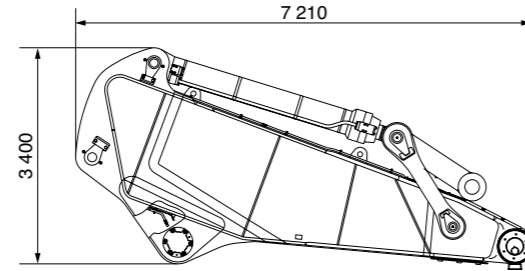

Width : 2 360

Boom assembly
Weight : 40 900 kg

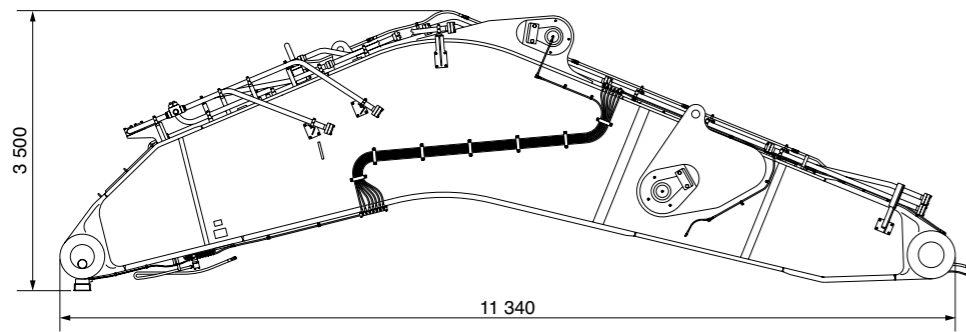

Width : 2 880

Handrails
Weight : 18 kg x 2

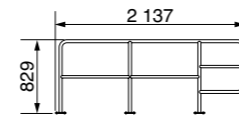

Width : 50

Boom cylinders
Weight : 6 880 kg x 2

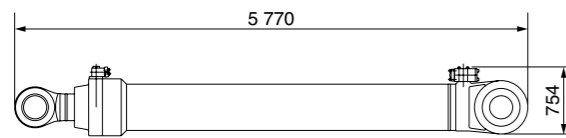

Width : 640

Arm cylinders
Weight : 4 690 kg x 2

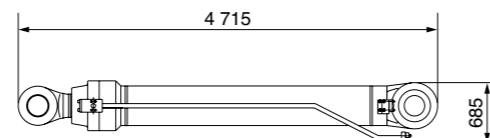

Width : 865

Clamp assembly
Weight : 49 kg

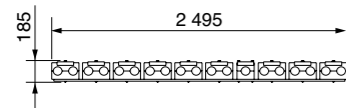

Width : 100

LOADER ATTACHMENTS

Unit: mm

Front bucket
Capacity ; 27.0 m³ (heaped)
Weight : 18 100 kg

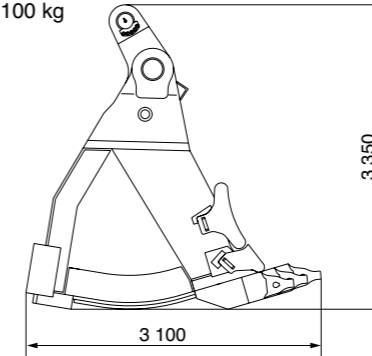

Width : 4 782

Rear bucket
Weight : 20 500 kg

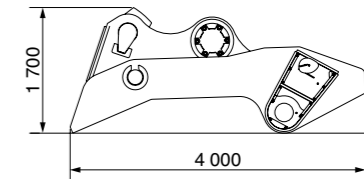

Width : 4 790

Dump cylinders
Weight : 985 kg x 2

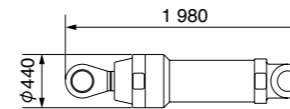

Width : 443

Arm assembly
Weight : 21 300 kg

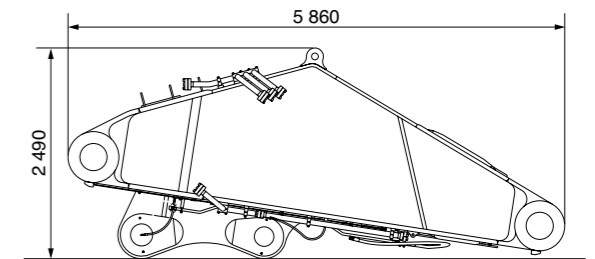

Width : 3 210

Handrails
Weight : 28 kg x 2

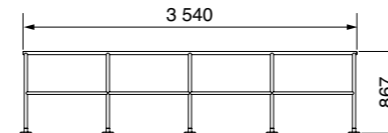

Width : 50

Boom assembly
Weight : 36 400 kg

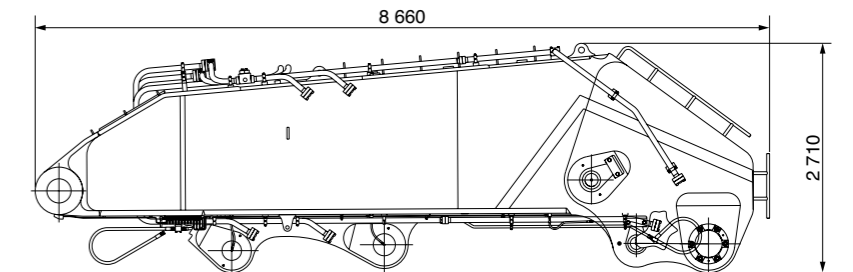

Width : 3 210

LOADER ATTACHMENTS

Unit: mm

Arm cylinder
Weight : 4 320 kg

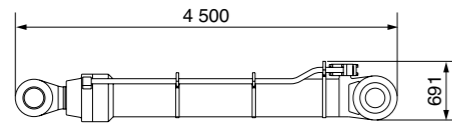

Width : 790

Boom cylinders
Weight : 6 600 kg x 2

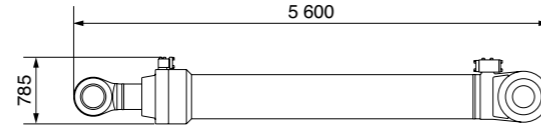

Width : 640

Level cylinder
Weight : 3 840 kg

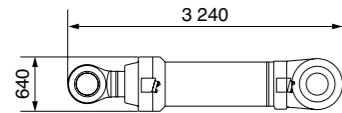

Width : 1 050

Bucket cylinders
Weight : 4 060 kg x 2

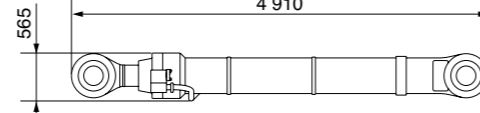

Width : 980

LIFTING CAPACITIES

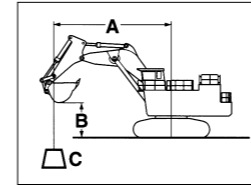

A: Load radius
B: Load point height
C: Lifting capacity

METRIC MEASURE

Rating over-side or 360 degree Rating over-front Unit: 1 000 kg

Conditions	Load point height	Load radius								At max. reach				
		8 m		10 m		12 m		14 m		16 m		meter		
EX5500-6 Boom Arm Bucket	14 m					*55.4	*55.4	*45.4	*45.4			*44.3	*44.3	14.0
	12 m					*58.6	*58.6	*57.0	*57.0			*42.7	*42.7	15.2
	10.6 m													
	5.3 m													
SAE, PCSA : 29.0 m ³ CECE : 26.0 m ³	8 m			*73.6	*73.6	*70.9	*70.9	*65.6	*65.6			*42.8	*42.8	15.9
	6 m					*87.8	*87.8	*70.2	*70.2	54.3	*56.2	*47.2	*47.2	16.6
Shoes 1 400 mm	4 m			*118.2	*118.2	*89.8	*89.8	70.3	*70.5	52.7	*54.8	48.7	*50.1	16.5
	2 m			*116.1	*116.1	*88.3	*88.3	67.9	*68.2	*50.2	*50.2	*47.9	*47.9	16.2
	0 (Ground)			*107.6	*107.6	*82.2	*82.2	*61.9	*61.9			*44.5	*44.5	15.6
	-2 m	*117.3	*117.3	*92.1	*92.1	*69.8	*69.8	*48.3	*48.3			*38.9	*38.9	14.7

- Notes:
1. Ratings are based on SAE J1097.
 2. Lifting capacity of the EX Series does not exceed 75% of tipping load with the machine on firm, level ground or 87% full hydraulic capacity.
 3. The load point is a hook (not standard equipment) loaded on the back of the bucket.
 4. *Indicates load limited by hydraulic capacity.

These specifications are subject to change without notice.
Illustrations and photos show the standard models, and may or may not include optional equipment, accessories, and all standard equipment with some differences in color and features.
Before use, read and understand the Operator's Manual for proper operation.

