

EH series

HITACHI

# EH

# 4000ACII



## DUMP TRUCK

- **Model Code** : EH4000ACII
- **Nominal Payload with Standard Equipment** : 222 tonnes (244.7 tons)
- **Target Gross Machine Operating Weight with Standard Tires** : 384 000 kg
- **Engine** : Cummins QSKTA60-CE  
Rated Power 1 864 kW (2 500HP)



# Refined engineering and advanced Hitachi AC Drive system technology has created hauling capability well recognized in the surface mining industry.

The EH4000ACII continues to prove itself as an exceedingly capable and reliable solution to mine applications worldwide.



### AC Drive Proven Performance & Economic Advantages

Hitachi engineered AC drives make your hauler a more valuable asset in your mining operation. Better performance, higher availability, and significant reductions in maintenance and operating costs - result in a lower cost per tonne and a higher return on your investment.



### High-Powered Engine

Strong, reliable power is provided by the Cummins QSKTA60-CE engine. This U.S. Tier 2 emission certified engine maintains a low fuel consumption level.



### Long Frame Life

A fabricated box section and rectangular frame rail construction provides superior resistance to bending and torsional loads. One-piece top and bottom flanges eliminate cross member tie-in joints and provide a larger exposed center area for access to major components.



### Tough Body

The Hitachi horizontal stiffener design minimizes stress concentrations by dissipating load shocks over the entire body length. Closely spaced stiffeners provide additional protection by minimizing distances between unsupported areas.

### Well Matched: EH4000ACII & Excavators

Excavator	EX3600-6		EX5500-6		EX8000-6
	BH	LD	BH	LD	LD
Front					
Bucket	*22.0 m <sup>3</sup>	21.0 m <sup>3</sup>	*29.0 m <sup>3</sup>	27.0 m <sup>3</sup>	40.0 m <sup>3</sup>
Passes	6	6	4	5	3

BH: Backhoe LD: Loading shovel \*: SAE, PCSA heaped capacity

Note: Photos in this brochure may include optional equipment. They may also include custom-made options to meet specific user needs.



# AC Drive Advantage



Hitachi AC drive technology provides superior truck performance with higher top speeds, better gradeability and stronger retardation. Hitachi inverter modules provide high rigid truck controlability and efficiency. The Hitachi AC wheel motors do not have commutators and brushes, which improves truck performance by providing reduced maintenance costs, higher truck availability and higher travel speeds. These advantages result in more productivity and lower costs per tonne. Hitachi AC drive systems also power electric train locomotives world wide.

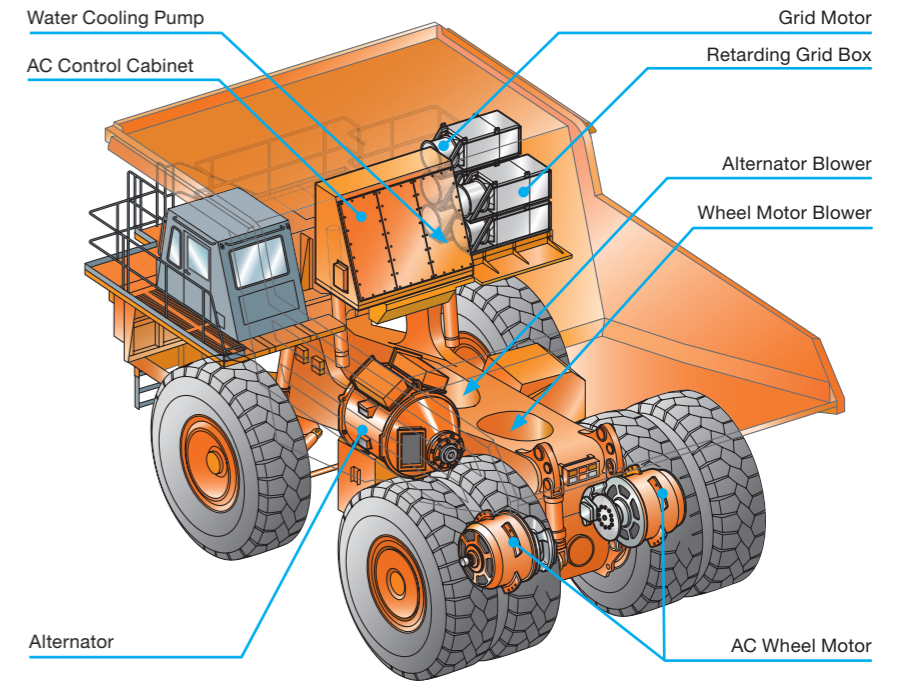

## Full Retarding Capability

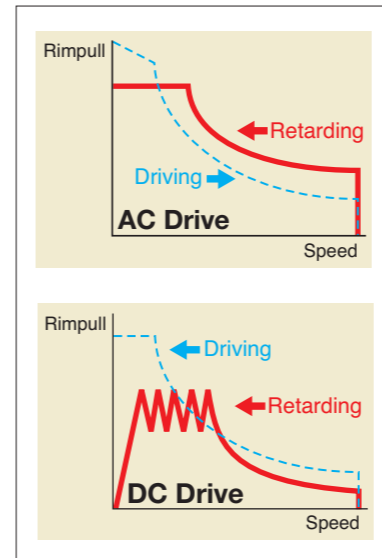

Hitachi AC drive systems provide more rimpull than comparable DC systems. Full retarding capability means the truck can be fully stopped without applying the service brake pedal.

## The AC Drive Wheel Motors

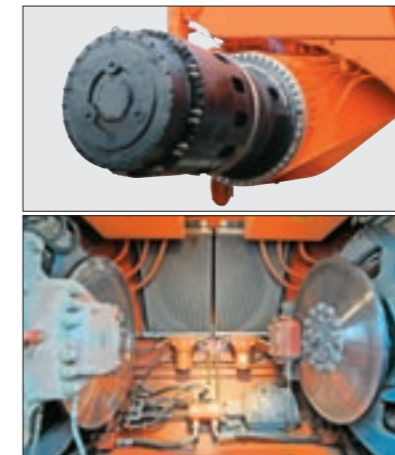

The Hitachi Dual Path Epicyclic Planetary design provides high efficiency and easy maintenance. Allowing the 1st (outer) planetary carrier to travel at wheel speed provides lower operating temperatures. Better component and lubricant life is the result of an inverter controlled lubricant circulation system that includes lubricant cooling and filtration.

## AC Drive Control

**Brake Blending**, which combines service braking with electric retarding, is applied automatically through the AC drive control system to stop the hauler when travel speed is below 0.5 km/hr. Therefore, with the exception of emergencies, the driver can stop the truck using the retarder pedal only, resulting in easy machine operation and longer time between brake service intervals.

**Auto Cruise Control** keeps vehicle speed constant within the set range by limiting the minimum vehicle speed.

**Auto Retarding Control** keeps vehicle downhill speed constant within the set range by limiting the maximum vehicle speed.



# Ease of Operation



## HI-TECH ROPS/FOPS Cab

The new HI-TECH ROPS/FOPS cab has been newly equipped with a Hitachi controller and a large centrally mounted, color Liquid Crystal Display (LCD) as used in Hitachi large sized excavators. Double wall construction of 11 gauge inner and outer steel panels produces a more structurally sound cab. A three-point rubber isolation-mount arrangement minimizes vibration to the operator compartment.



## Superior Suspension

The Hitachi trailing arm suspension system delivers excellent maneuverability, even at higher speeds. The trailing arm layout offers greater ease of servicing while improving truck performance compared to suspended king-pin designs. The pivot mounting of the trailing arm design allows only axial input to the strut and allows wheel movement to the vertical plane only.

### Features:

- Lateral forces that act on the front wheels are minimized, resulting in reduced tire scuffing.
- Dynamic friction (side-wall force) within the strut is low due to the features of the trailing arm suspension design, allowing the use of a lighter strut engineered to a smaller diameter and longer stroke.
- The necessary frame bulk (horse-collar structure) needed to mount a suspended king-pin is non-existent.
- The elimination of the "horse-collar" member provides greater engine access.

- The NEOCON strut used with the trailing arm suspension, improves operator and component isolation, provides better hauler stability and predictable operational control.
- Locating the king-pin close to the wheel assembly and at a slight angle results in low "Dry Park Steering" effort.
- Development of the compressible media, NEOCON- E™ fluid (proprietary, silicone based, environmentally friendly) for use in the suspension strut with Helium gas, results in an improved energy absorption (isolation) system and an improved energy release (stability) system that responds favorably whether traveling empty or loaded in a wide range of ambient temperatures.

The trailing arm suspension design allows the front struts to be removed and installed without removing the front brakes or tires. This means fewer tools and less labor time are required, resulting in less downtime and higher productivity.

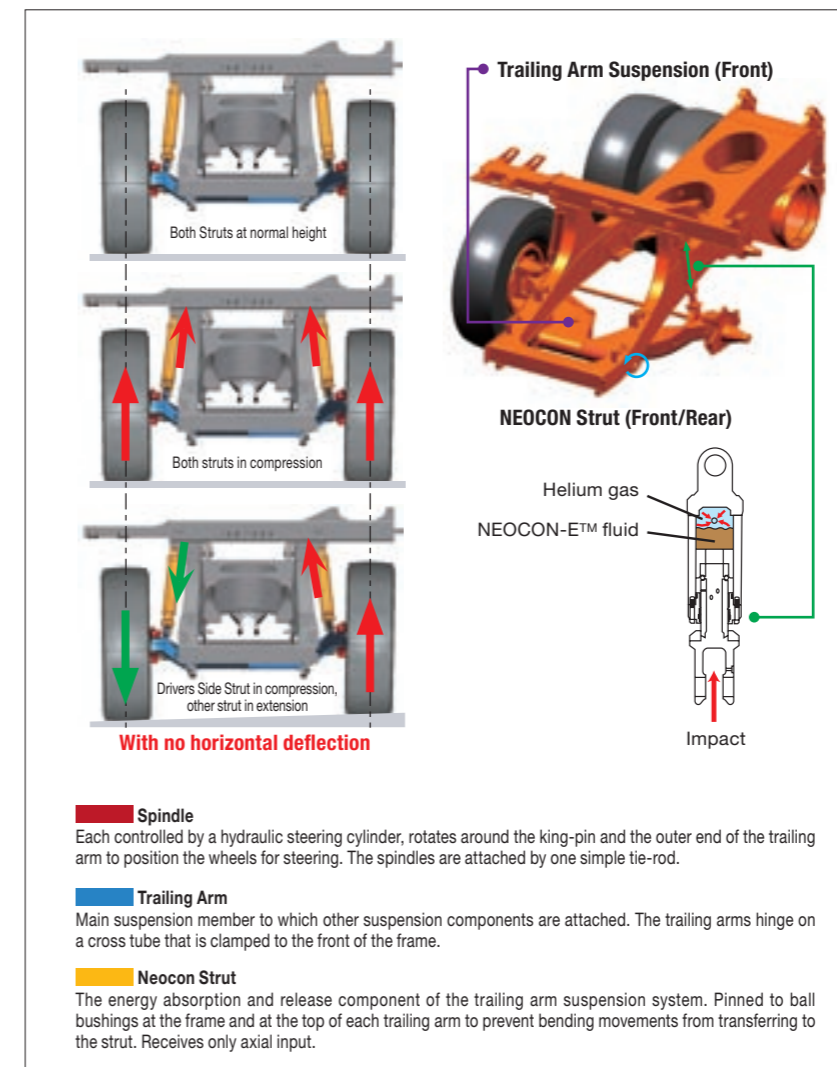

## THE FAST FILLING SYSTEM



1. Hydraulic oil
2. Coolant 1
3. Coolant 2
4. Grease
5. Engine oil

The fast filling system, provided standard on the left side of the radiator, allows direct access at ground level for fast feeding of coolant, grease, hydraulic oil and engine oil. (Couplers are optional.)





# SPECIFICATIONS

## ENGINE

Model .....	Cummins QSKTA60-CE
Type.....	4 Cycle Diesel w/ MCR fuel system
Aspiration.....	1 stage Turbocharged & Low Temperature Aftercooled
Emission Certification .....	U.S. EPA Tier 2
Rated Power	
SAE J1995, gross .....	1 864 kW (2 500 HP) at 1 900 min <sup>-1</sup> (rpm)
Net .....	1 771 kW (2 370 HP) at 1 900 min <sup>-1</sup> (rpm)
Maximum Torque	
(SAE J1995) .....	9 839 N-m (1 004 kgf-m) at 1 500 min <sup>-1</sup> (rpm)
No. Cylinders .....	16
Bore & Stroke.....	159 x 190 mm
Displacement .....	60 L
Starting .....	24 Volt Electric

## ELECTRICAL DRIVE

HITACHI AC-Drive System

### AC Control Cabinet

Rectifier	Number of units.....	1
	Rated capacity .....	1 680 kW
Inverter	Number of units.....	2
	Rated capacity per unit.....	1 000 kVA
Chopper	Number of units.....	2
	Rated capacity per unit.....	1 950 kW

Cabinet is pressurized to reduce dust and moisture. Equipped with a reliable liquid cooling system and lockable doors for safety. Equipped with auxiliary inverters to provide grid motors, blower motor for wheel motors, cabinet coolant pump, and final drive lubricant pump with adequate AC current. The AC drive motors can be controlled independently of engine speed, resulting in stable cooling performance on retarding or slowing down. Uniquely constructed for the Rigid Truck application.

### Alternator

Number of units .....	1
Capacity.....	1 900 kVA at 1 900 min <sup>-1</sup> (rpm)

Equipped with an auxiliary alternator that provides AC current to grid motors, blower motors, cabinet coolant pump and final drive lubricant cooling & filtrating pump. Air cooled by an AC drive blower.

### AC Wheel Motor

Number of units .....	2
Capacity per unit .....	720 kW

Air cooled by AC drive blower.

### Retarding Grid Box

Number of modules.....	5
Capacity per unit .....	625 kW (3 min.)

Equipped with inverter controlled variable speed cooling fan.

### Axle

Planetary Ratio .....	35.3 : 1
Maximum Speed .....	56 km/h

## TIRES

<b>Standard - Front and Rear</b>	<b>Rim Width</b>
46/90R57 .....	736.6 mm (29 in)
<b>Optional - Front and Rear</b>	<b>Rim Width</b>
40.00R57 .....	736.6 mm (29 in)

Optional tires and tread patterns may be available. Certain job conditions may require higher TKPH (TMPH) in order to maintain maximum production. Hitachi recommends evaluating the job conditions and consulting with the tire manufacturer to make proper tire selection.

## ELECTRICAL SYSTEM

Twenty-four volt system. 140 ampere engine driven alternator. Four 245H52, 12 volt, heavy duty batteries connected in series/parallel.

## BODY CAPACITIES

Struck (SAE).....	102.6 m <sup>3</sup>
Heap 3:1 .....	133.4 m <sup>3</sup>
Heap 2:1 (SAE).....	148.2 m <sup>3</sup>

Body capacity and payload subject to change based on customer specific material density and application.

## STEERING SYSTEM

Closed-center, full time hydrostatic power steering system using two double-acting cylinders and a variable displacement piston pump. Hitachi accumulators provide supplementary steering in accordance with ISO 5010 (SAE J1511), supplying a constant steering rate under all conditions. A tilt/telescopic steering wheel with 35 degrees of tilt and 57 mm telescopic travel is standard.

Turning Diameter (ISO 7457) .....	30.2 m
-----------------------------------	--------

## HYDRAULIC SYSTEM

Two (2) Hitachi three-stage, double-acting cylinders, with electronic controlled cushioning in retraction and extension, containing dual rod seals and urethane energized scrapers, inverted and outboard mounted. A tandem piston pump combines with four position electronic pilot controlled hoist valve. The electrical controller is mounted to the shift tower.

Body Raise Travel .....	57.5 degrees
Body Raise Time .....	18.0 s
Body Down Time (Float) .....	13.0 s

## BRAKE SYSTEM

Brake system complies with ISO 3450 (SAE J1473).

### Service

An all-hydraulic actuated braking system provides precise braking control and quick system response. The system is pressure proportioned, front to rear, for improved slippery road control.

### Front Axle – Dry Disc

Disc diameter each (2 discs/axle, 3 calipers/disc) .....	121.6 cm
--	----------

### Rear Axle – Oil-cooled Wet Disc

Brake surface area per axle .....	75 760 cm <sup>2</sup>
-----------------------------------	------------------------

### Secondary

Dual independent hydraulic circuits within the service brake system provide fully modulated reserve braking capability. Both front and rear brakes are automatically applied when loss of supply pressure is detected.

### Parking

Two spring on, hydraulic off armature disc brake heads provide effective parking. The braking system complies with ISO 3450 (SAE J1473).

### Retarder

Superior retardation to zero speed on grades is achieved through AC wheel motors in conjunction with five Hitachi resistor grid packages. Service brake blending occurs at speeds below 0.5 km/h.

Maximum dynamic retarding (Standard) .....	3 200 kW
--	----------

### Load/Dump Brake Apply

Through activation of a switch by the operator, a solenoid is energized, sending full brake pressure to apply the rear Wet Disc brakes. For use during the load and dump cycles.

## WEIGHTS (Approximate)

Net machine weight stated below includes standard equipment. Net machine weight changes will directly affect the Nominal Payload.

### With Standard 46/90R57 Tires

Chassis with Hoist.....	138 140 kg
Body .....	23 860 kg
Net Machine Weight.....	162 000 kg

The Net Machine Weight specification includes operator and 100 % fuel.

Nominal Payload .....	222 tonnes
Target GMOW.....	384 000 kg

### Note:

The Nominal Payload specification is calculated using the Hitachi Loading Policy. Specific job site requirements may result in an adjustment to the Nominal Payload weight. Consult your Hitachi dealer for a truck configuration which will match your haulage application.

Weight Distribution	<b>Front</b>	<b>Rear</b>
Empty	48 %	52 %
Loaded	33 %	67 %

### With Optional 40.00R57 Tires

Chassis with Hoist.....	136 140 kg
Body .....	23 860 kg
Net Machine Weight.....	160 000 kg

The Net Machine Weight specification includes operator and 100 % fuel.

Nominal Payload .....	206 tonnes
Target GMOW.....	366 000 kg

### Note:

The Nominal Payload specification is calculated using the Hitachi Loading Policy. Specific job site requirements may result in an adjustment to the Nominal Payload weight. Consult your Hitachi dealer for a truck configuration which will match your haulage application.

Weight Distribution	<b>Front</b>	<b>Rear</b>
Empty	48 %	52 %
Loaded	33 %	67 %

## HI-TECH ROPS/FOPS CAB

### New HI-TECH ROPS/FOPS Cab

ROPS complies with ISO3471 and SAE J1040-May 94, FOPS complies with ISO3449. A three-point rubber ISO-mount arrangement to the high-arch cross member minimizes vibration transfer to the operator compartment. New wider cab with double full size seat available and enough trainer's leg space brings comfortable operating and training.

### Comfort and Ease of Operation

New wrap-around style dashboard means controls are within easy reach and visual contact. A full complement of easy-to-read automobile type color Liquid Crystal Display (LCD) monitor and warning system, a spacious environment, six-way adjustable operator's air suspension seat, tilt/telescopic steering wheel, filtered adjustable air vents, all contribute to operator safety and comfort.

## Monitoring System

A new Hitachi system monitor provides display information and diagnostics of all onboard systems and controls which include the engine and Hitachi AC drive. Data links offer complete integration, while a color Liquid Crystal Display (LCD) clearly details machine functions. Downtime is minimized with faster and more reliable troubleshooting and analysis. A new Hitachi load monitoring system offers benefits such as better equipment utilization on the jobsite, accurate unit and fleet production results, and benchmark unit statistics against fleet results. Cycle time, distance and cycle count can all be measured and recorded as information that can help in developing higher productivity. The Hitachi load monitoring system is fully integrated with the Hitachi vehicle monitoring system and display interface, avoiding potential failure or error common in aftermarket systems.

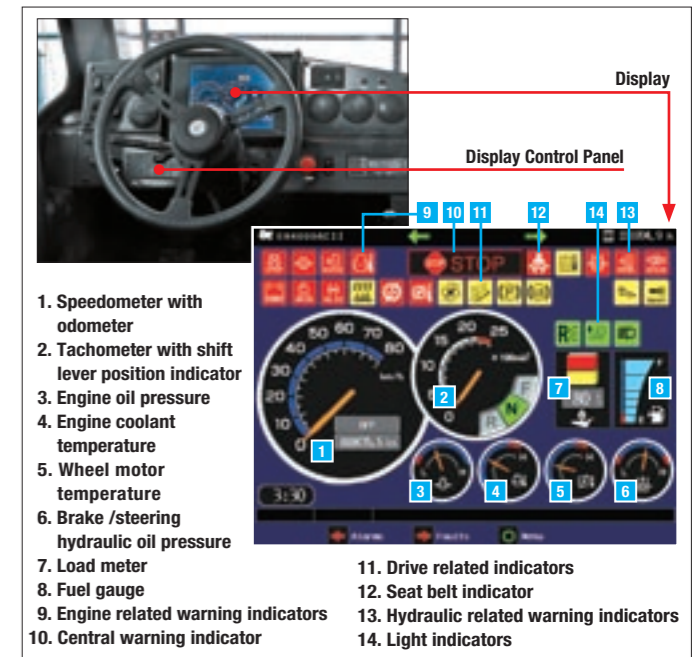

## Camera Monitoring System

Included as standard safety equipment, an analog monitor has been mounted to the dashboard to display live camera information of the rear and right front area.

## Excellent Serviceability

A removable front cover of the cab allows easy access to the service brake valve and A/C filter. A removable cover located behind the seat provides easy access to the electric components, Hitachi controller, and all electrical junction points.

## SUSPENSION

### Front Suspension

Independent trailing arms make up the front axle. NEOCON struts containing energy-absorbing gas and compressible NEOCON-E™ fluid are mounted between the trailing arms and frame. Inherent in the Neocon strut design is a variable damping and rebound feature.

### Rear Suspension

"A" frame structure, integral with axle housing, links the drive axle to the frame at forward center point with pin and spherical bushing. A track rod provides lateral stability between the frame and drive axle. Heavy-duty rear-mounted NEOCON struts containing energy-absorbing gas and compressible NEOCON-E™ fluid suspend the drive axle from the frame. Integral variable damping and rebound feature included.



# SPECIFICATIONS

## FRAME

Full fabricated box section main rails with section height tapered from rear to front. Narrow at the rear to support the load and wider at the front allowing truck stability and excellent engine access for servicing. One piece top and bottom flanges that eliminate cross member tie in joints and provide a large exposed center area for access to major components. Large radii at frame junctions are blended and ground to minimize stress concentrations. Weld joints are oriented longitudinally to the principal flow of stress for greater durability and more strength.

The new "bolt-on" High Arch Design requires less assembling time and no welding. The design provides higher structural quality and better serviceability during engine overhaul.

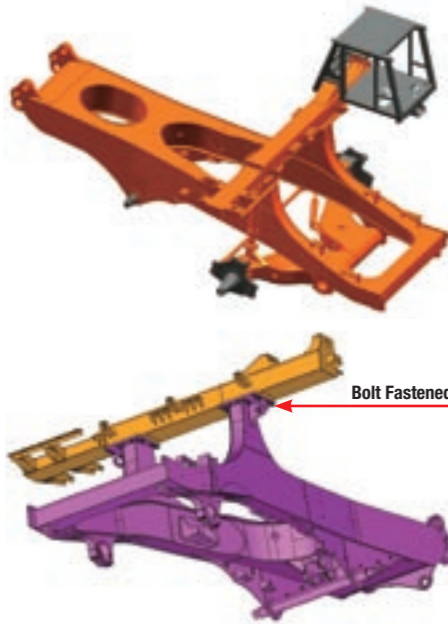

## BODY

An extended canopy protects the service deck area. High tensile strength 400 BHN abrasion and impact resistant alloy steel is used for the plate indicated below:

Floor.....	16 mm
Front.....	10 mm
Sides.....	10 mm
Canopy.....	6 mm
Corners.....	12 mm



High strength 690 N/mm<sup>2</sup> (100 000 psi) alloy steel is also used for the canopy side members and floor stiffeners. The body is rubber cushioned on the frame.

### Optional Body Liners

Floor & Corners.....	12 mm
Sides & Front.....	6 mm
Canopy.....	6 mm

Special plate thicknesses and partial plates are available.

## SERVICE CAPACITIES

Main Accumulator.....	85 L
Crankcase (includes filters).....	261 L
Engine Cooling System.....	619 L
Fuel Tank (Standard).....	2 680 L
Fuel Tank (Optional).....	4 620 L
Hydraulic System.....	750 L
Brake cooling system.....	250 L
Planetary Drives (L&R).....	300 L
Front Wheels (L&R).....	34 L
Windshield Washer.....	20 L

## PERIMETER VISIBILITY

The addition of mirrors and cameras to the base model make the truck compliant to the perimeter viewing requirement of standards ISO 5006 and ISO 14401.

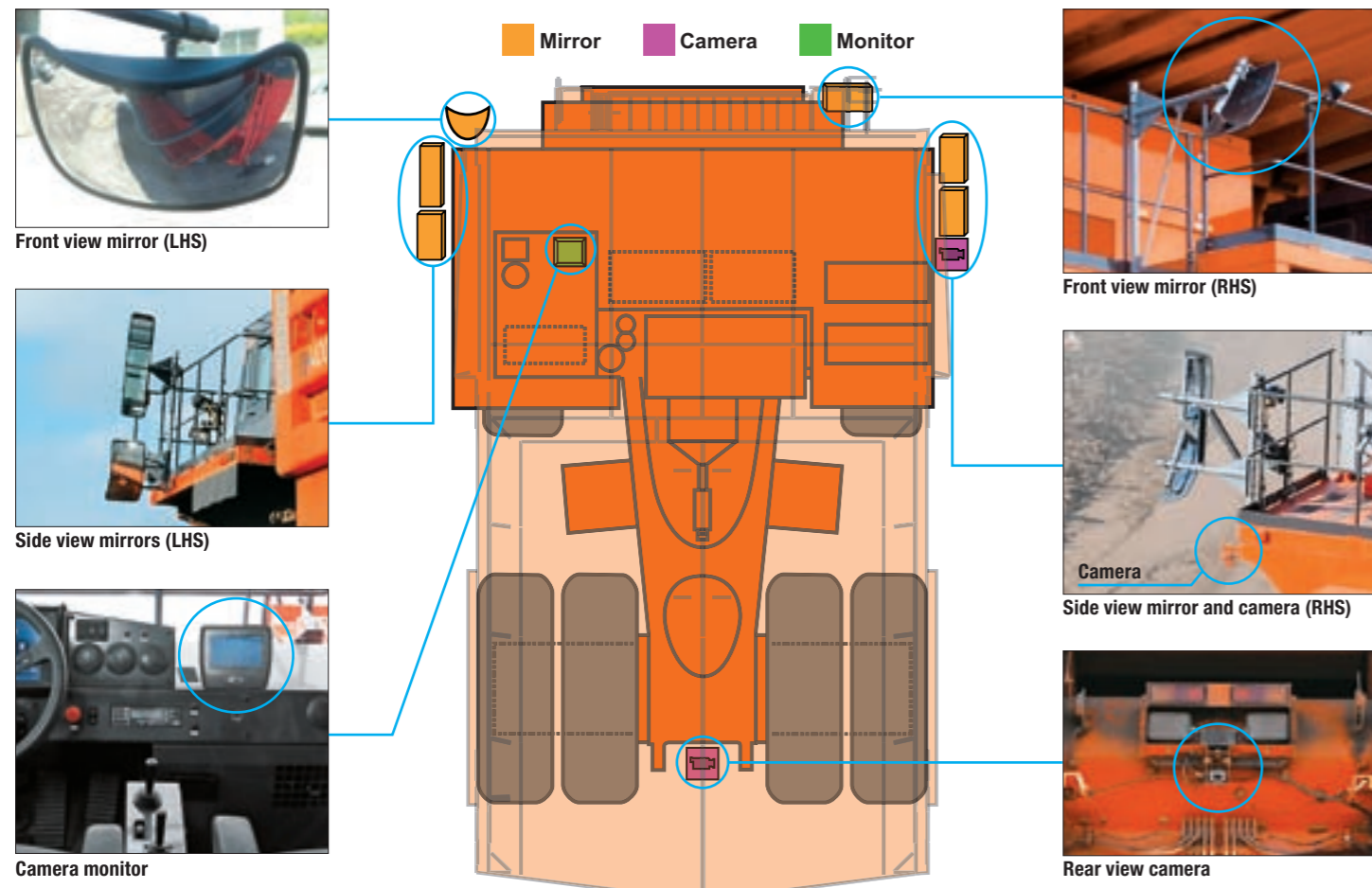

# EQUIPMENT

## STANDARD EQUIPMENT

### GENERAL

AC drive system	Fuel/Water separator
Auto cruise control	Fuel tank, 2 680 L
Auto retarding control	Ground level battery box
Brake blending control	Ground level relay box
Control cabinet	IGBT controlled blower fan motors (2)
pressurized/liquid cooled/lockable	IGBT controlled final drive lubricant motor (1)
Automatic lubrication system (Lincoln)	IGBT controlled grid fan motors (5)
Battery isolation switch	Load weighing system
Body prop pins	NEOCON suspension struts
Deck mounted muffler	Operator arm guard
Deck mounted stone guards	Rear view camera
Diagonal front stairway	Rear view mirrors (4)
Electric controlled hoist system	Rims, available for 40.00R57 & 46/90R57 tires
Electric horns (4)	Side view camera (RHS)
Engine access ladders (2)	Suction port shut off valve at hydraulic tank
Engine shutdown switch	Supplementary front braking system, accumulators
Beside engine (2)	Supplementary rear braking system, accumulators
Ground level, on bumper (1)	Supplementary steering system, accumulators
Inside rear axle (1)	Tire guards
Fan and belt guards	Tow hooks, front
Fan clutch	Tow lugs, rear
Fast fluid filling system	
Fast fuel filling system provision	
Final drive lubricant cooling	
Final drive lubricant filtration	
Front view mirror, LHS/RHS	

### CAB

Air conditioner	Seat with 2-point, 50 mm width seat belt
AM-FM radio	Full size operator's seat, air suspension & 6 position
Auxiliary outlet, 12 volt	Regular size trainer's seat, mechanical & adjustable
Camera monitor	Tinted safety glass, with roll-down windows
Engine shutdown switch	12 volt accessory connection
Heater and defroster	
Integral ROPS/FOPS cab	
LCD system monitor	
Load and dump switch	

### INDICATORS AND GAUGES SHOWN ON MONITOR DISPLAY

Brake/steering hydraulic oil pressure gauge	HCM code
Central warning indicator	Message
Clock	SAE code
Coolant temperature gauge	Light indicators
Drive related warning indicator	Load meter
Engine oil pressure gauge	Shift lever position indicator
Engine related warning indicators	Speedometer with odometer
Engine stop warning indicator	Stop valve warning indicator
Fuel gauge	Tachometer
Hour meter	Turn signal indicator
Hydraulic related warning indicators	Wheel motor temperature gauge

### MACHINE LIGHTS

Backup lights (2)	Engine compartment lights (2)
Clearance lights (4)	Halogen headlights (8)
Combination stop and tail lights (2)	Payload external indicators, 2 locations of 2 lights each
Deck lights (2)	Rear axle compartment light
Diagonal front stairway light	

## OPTIONAL EQUIPMENT

Auxiliary dump connection	Fuel tank inlet access ladder
Auxiliary steer connection	Halogen front tire lights (2)
Body liners (400BHN)	Heated mirrors
Body prop cable	HID headlights (6)
Body sizes **	Loadweight display (1) or (2)
Cold weather package **	Seat with 3-point, 50 mm width seat belt
Extreme cold weather package includes Kim Hot coolant and oil pan heater, and a fan clutch	Full size operator's seat, air suspension & 6 position
Mild cold weather package includes Kim Hot coolant and oil pan heater	Full size trainer's seat, air suspension & 6 position
Continuous heated body	Sound attenuation package **
Fast fluid filling system couplers **	Spare rim
Fast fuel filling system coupler **	Trolley assist configuration **
Fuel tank, 4 620 L	** : engineered on request

## OPTIONAL EQUIPMENT WEIGHT

Body liners (400BHN) plates including floor & corners (12 mm thicknesses), sides & front and canopy (6 mm thicknesses).....	8 201 kg
4620 L fuel tank with 100 % fuel (additional weight to the standard tank with 100 % fuel).....	1 954 kg
Gridbox guard.....	128 kg
Loadweight display (1).....	75 kg



# DIMENSIONS

Unit: mm

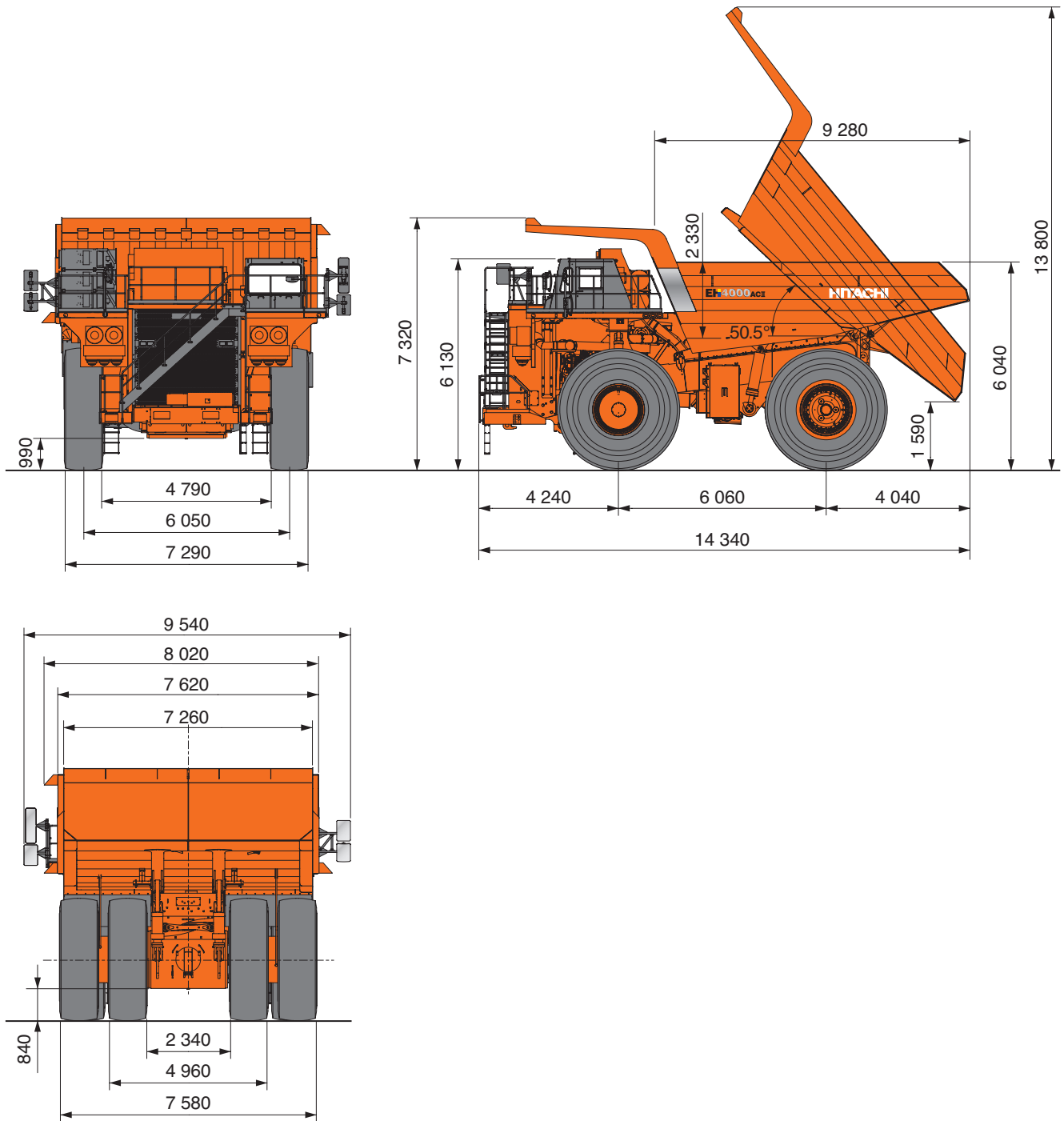

**NOTES:**

Dimensions shown are for an empty machine with 46/90R57 tires.

These specifications are subject to change without notice. Illustrations and photos show standard models, and may or may not include optional equipment, accessories, and all standard equipment with some differences in color and features. Before use, please read and understand the Operator's Manual for proper operation.

