

# Mining Excavator

# R 995

|  |  |
|--|--|
| Operating Weight<br>with Backhoe Attachment: | 441,000 kg / 972,240 lb                                    |
| with Shovel Attachment:                      | 450,000 kg / 992,080 lb                                    |
| Engine Output:                               | 1,600 kW / 2,140 hp  |
| Bucket Capacity:                             | 24.00 – 28.00 m <sup>3</sup> / 31.4 – 36.6 yd <sup>3</sup> |
| Shovel Capacity:                             | 24.00 – 28.00 m <sup>3</sup> / 31.4 – 36.6 yd <sup>3</sup> |



# LIEBHERR

# Technical Data



## Engine

1 MTU diesel engine

Rating per SAE J 1995 \_\_\_\_\_ 1,600 kW/2,140 hp at 1,800 rpm

Model \_\_\_\_\_ 16 V 4000 E 20 (Tier 1)

Type \_\_\_\_\_ 16 cylinder turbocharged V-engine, after-cooled, two separate water cooling circuits, common-rail direct injection system

Displacement \_\_\_\_\_ 65 l/3,967 in<sup>3</sup>

Bore/Stroke \_\_\_\_\_ 165/190 mm/6.5/7.48 in

Engine cooling system \_\_\_\_\_ fans driven via hydraulic piston motor

Air cleaner \_\_\_\_\_ dry-type air cleaner with pre-cleaner, with automatic dust ejector, primary and safety elements

Fuel tank \_\_\_\_\_ 10,000 l/2,640 gal

Electrical system

Voltage \_\_\_\_\_ 24 V

Batteries \_\_\_\_\_ 8 x 170 Ah/12 V

Alternator \_\_\_\_\_ 24 V/240 Amp

Engine idling \_\_\_\_\_ sensor controlled

Electronic engine control system \_\_\_\_\_ engine speed sensing over the entire engine RPM range. Provides integration of engine with other machine systems



## Electric System

Electric isolation \_\_\_\_\_ easy accessible battery isolations

Working lights \_\_\_\_\_ high brightness halogen lights:

- 4 on working attachment
- 2 on LHS of uppercarriage
- 2 on RHS of uppercarriage
- 2 on counterweight

Xenon lights in option

Emergency stop switches \_\_\_\_\_ at ground level, in hydraulic compartment, in engine compartment and in operator cab

Electrical wiring \_\_\_\_\_ heavy duty execution in IP 65 standard for operating conditions of - 50 °C to 100 °C/ - 58 °F to 212 °F



## Swing Drive

Hydraulic motor \_\_\_\_\_ 4 Liebherr axial piston motors

Swing gear \_\_\_\_\_ 4 Liebherr planetary reduction gears

Swing ring \_\_\_\_\_ Liebherr, sealed triple roller swing ring, internal teeth

Swing speed \_\_\_\_\_ 0 - 3.7 rpm

Swing-holding brake \_\_\_\_\_ hydraulically released, maintenance-free, multi-disc brakes integrated in each swing gear



## Hydraulic System

Hydraulic pumps for attachment and travel drive \_\_\_\_\_ 6 variable flow axial piston pumps

Max. flow \_\_\_\_\_ 6 x 840 l/min./6 x 222 gpm

Max. hydr. pressure \_\_\_\_\_ 320 bar/4,640 psi

Hydraulic pumps for swing drive \_\_\_\_\_ 4 reversible swash plate pumps, closed-loop circuit

Max. flow \_\_\_\_\_ 4 x 361 l/min./4 x 95.4 gpm

Max. hydr. pressure \_\_\_\_\_ 350 bar/5,076 psi

Pump management \_\_\_\_\_ electronically controlled pressure and flow management with oil flow optimisation

Hydraulic tank capacity \_\_\_\_\_ 3,030 l/800 gal

Hydraulic system capacity \_\_\_\_\_ 6,400 l/1,690 gal

Hydraulic oil filter \_\_\_\_\_ 1 high pressure safety filter after each high pressure pump + fine filtration of entire return flow

Hydraulic oil cooler \_\_\_\_\_ 2 separate coolers, 3 temperature controlled fans driven via hydraulic piston motors



## Uppercarriage

Design \_\_\_\_\_ torque resistant designed upper frame in box type construction for superior strength and durability

Attachment mounting \_\_\_\_\_ parallel longitudinal main girders in box-section construction

Machine access \_\_\_\_\_ on the cab side with a hydraulically driven access ladder, additional emergency ladder in front of the cab



## Service Flap

Design \_\_\_\_\_ hydraulically actuated service flap, easily accessible from ground level to allow:

- fuel fast refill
- hydraulic oil refill
- engine oil quick change
- splitterbox oil quick change
- swing gearbox oil quick change
- swing ring teeth grease barrel refilling via grease filter
- attachment/swing ring bearing grease barrel refilling via grease filter
- windshield washer water refilling

Quick coupler upon request



## Hydraulic Controls

Servo circuit \_\_\_\_\_ independant, electric over hydraulic proportional controls of each function

Emergency control \_\_\_\_\_ via accumulator for all attachment functions with stopped engine

Power distribution \_\_\_\_\_ via monoblock control valves with integrated primary relief valves and flanged on secondary valves for travel

Flow summation \_\_\_\_\_ to attachment and travel drive

Control functions

Attachment and Swing \_\_\_\_\_ proportional via joystick levers

Travel \_\_\_\_\_ proportional via foot pedals or hand levers

Bottom dump bucket \_\_\_\_\_ proportional via foot pedals

# Technical Data



## Operator's Cab

|                                     |  |
|-------------------------------------|--|
| Design                              | resiliently mounted, sound insulated, large windows for all-around visibility, integrated falling object protection FOPS   |
| Operator seat                       | suspended, body-contoured with shock absorber, adjustable to operator's weight   |
| Cabin windows                       | 20.5 mm/0.8 in tinted armored glass for front window and right hand side windows, all other windows in tinted safety glass, high pressure windshield-washer-system with 75 l/20 gal watertank, sun louvers on all windows in heavy duty design |
| Heating system/<br>Air conditioning | heavy duty, high output air conditioner and heater unit  |
| Cabin pressurization                | ventilation unit with filters  |
| Controls                            | joystick levers integrated into armrest of seat  |
| Monitoring                          | via LCD-Display, data memory   |
| Rear vision system                  | camera installation on counterweight and right-hand side of the uppercarriage displayed over an additional LCD-display   |
| Automatic engine shut off           | in case of low engine oil pressure or low coolant level  |
| Destroking of main pumps            | in case of engine overheating or low hydraulic oil level   |
| Safety functions                    | additional gauges with constant display for: engine speed, hourmeter, engine oil pressure, coolant temperature, hydraulic oil temperature  |
| Noise level (ISO 6396)              | $L_{pa}$ (inside cab) = 76,5 dB(A) with oil/water fans at 100 % and AC fan at 65 %   |



## Undercarriage

|                                   |  |
|-----------------------------------|--|
| Design                            | 3-piece undercarriage, box type structures for center piece and side frames, stress relieved         |
| Hydraulic motor                   | 2 axial piston motors per side frame   |
| Travel gear                       | Liebherr planetary reduction gear  |
| Travel speed                      | 0 – 2.7 km/h/0 – 1.67 mph  |
| Parking brake                     | spring engaged, hydraulically released wet multi-disc brakes for each travel motor, maintenance-free |
| Track components                  | maintenance-free combined pad-link, shovel style double grouser pad                                  |
| Track rollers/<br>Carrier rollers | 7/3  |
| Automatic track tensioner         | pressurized hydraulic cylinder, 1 per side frame with accumulator, maintenance free                  |
| Transport                         | undercarriage side frames are removable  |



## Central Lubrication System

|              |  |
|--------------|--|
| Type         | Lincoln Centromatic lubrication system for the entire attachment/swing ring bearing and teeth                        |
| Grease pumps | 2 Lincoln Powermaster pumps with switch over function, 1 Lincoln Flowmaster pump for swing ring teeth lubrication    |
| Capacity     | 600 l/158 gal bulk container for attachment/swing ring bearing, separated 80 l/21 gal container for swing ring teeth |
| Refill       | via the service flap for both containers with grease filters   |



## Attachment

|                       |   |
|-----------------------|---|
| Design                | box type structure with large steel castings in all high-stress areas   |
| Pivots                | sealed with double side centering with 1 single floating pin per side, all bearings with wear resistant, steel bushings, bolts hardened and chromium-plated |
| Hydraulic cylinders   | Liebherr design, all cylinders located in well protected areas  |
| Hydraulic connections | pipes and hoses equipped with SAE split flange connections  |
| Kinematics            | Liebherr parallel face shovel attachment geometry   |



# Dimensions

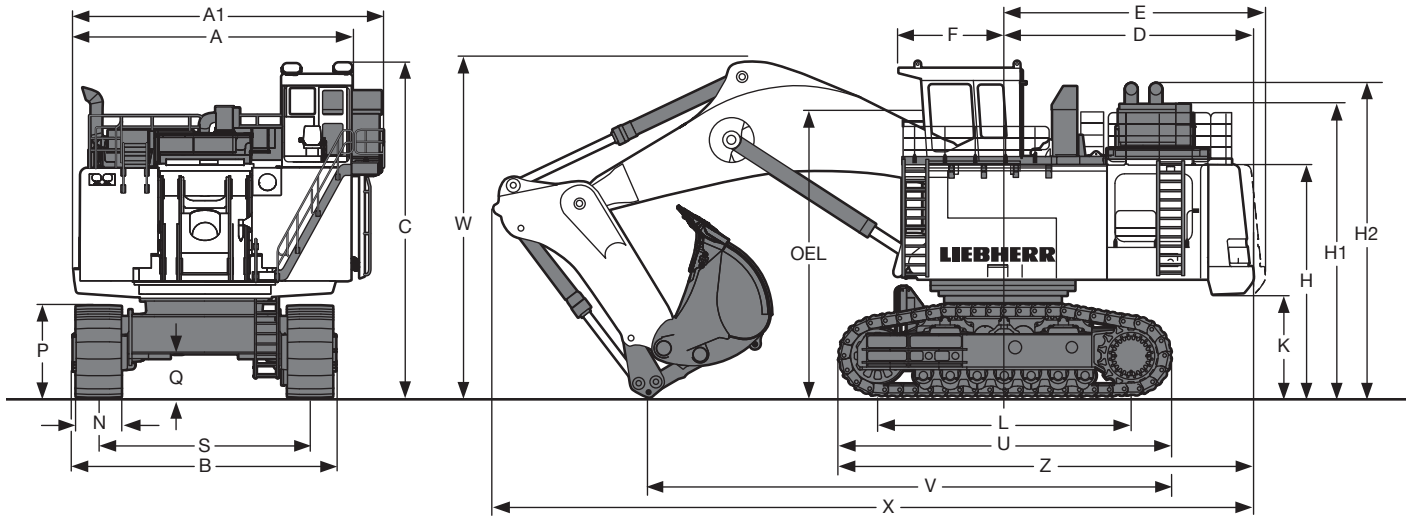

|    | mm/ft in      |
|----|---------------|
| A  | 7,400/24' 3"  |
| A1 | 8,230/26' 11" |
| C  | 8,820/28' 11" |
| D  | 6,590/21' 7"  |
| E  | 6,900/22' 7"  |
| F  | 2,810/ 9' 2"  |
| H  | 6,025/19' 9"  |
| H1 | 7,620/24' 11" |
| H2 | 8,170/26' 9"  |
| K  | 2,600/ 8' 6"  |
| L  | 6,700/21' 11" |

|     | mm/ft in             |
|-----|----------------------|
| U   | 8,877/29' 1"         |
| P   | 2,505/ 8' 2"         |
| Q   | 1,186/ 3' 10"        |
| S   | 5,600/18' 4"         |
| N   | 1,200/ 3' 11"        |
| B   | 6,960/22' 9"         |
| Z   | 11,000/36'           |
| V   | 13,200/43' 4"        |
| W   | 9,100/29' 10"        |
| X   | 19,600/64' 3"        |
| OEL | Operator's Eye Level |
|     | 7,450/24' 5"         |

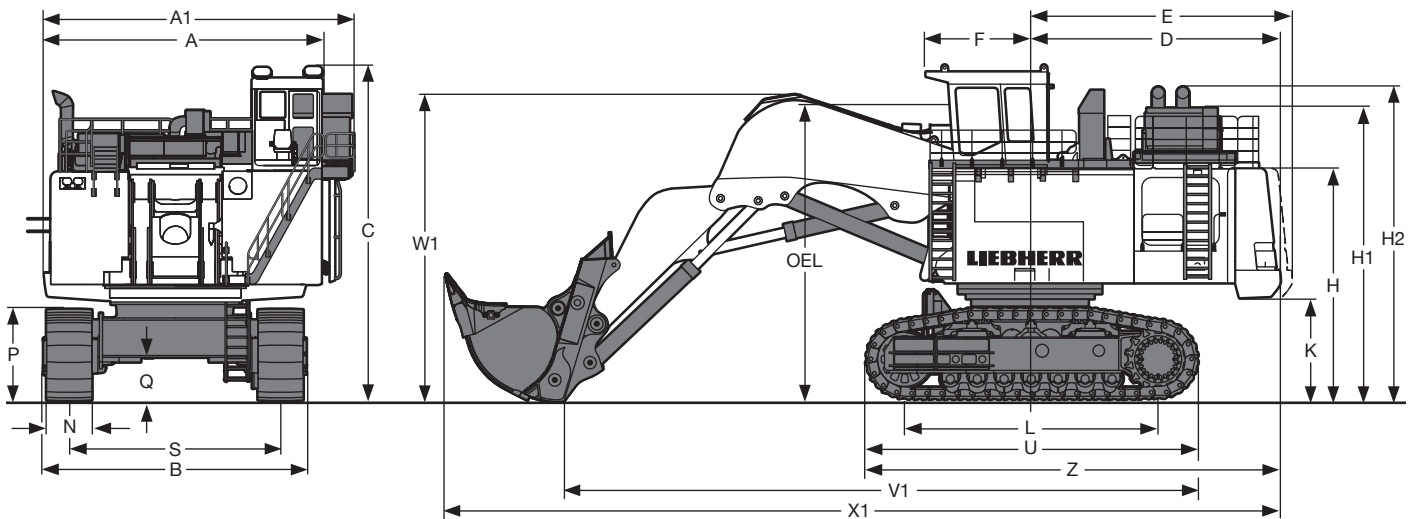

|    | mm/ft in      |
|----|---------------|
| A  | 7,400/24' 3"  |
| A1 | 8,850/29'     |
| C  | 8,820/28' 11" |
| D  | 6,590/21' 7"  |
| E  | 6,900/22' 7"  |
| F  | 2,810/ 9' 2"  |
| H  | 6,025/19' 9"  |
| H1 | 7,620/24' 11" |
| H2 | 8,170/26' 9"  |
| K  | 2,600/ 8' 6"  |
| L  | 6,700/21' 11" |

|     | mm/ft in             |
|-----|----------------------|
| U   | 8,877/29' 1"         |
| P   | 2,505/ 8' 2"         |
| Q   | 1,186/ 3' 10"        |
| S   | 5,600/18' 4"         |
| N   | 1,200/ 3' 11"        |
| B   | 6,960/22' 9"         |
| W1  | 8,000/26' 2"         |
| V1  | 17,000/55' 9"        |
| X1  | 22,100/72' 5"        |
| Z   | 11,000/36'           |
| OEL | Operator's Eye Level |
|     | 7,450/24' 5"         |

# Backhoe Attachment

with Gooseneck Boom 10.00 m/32'10"

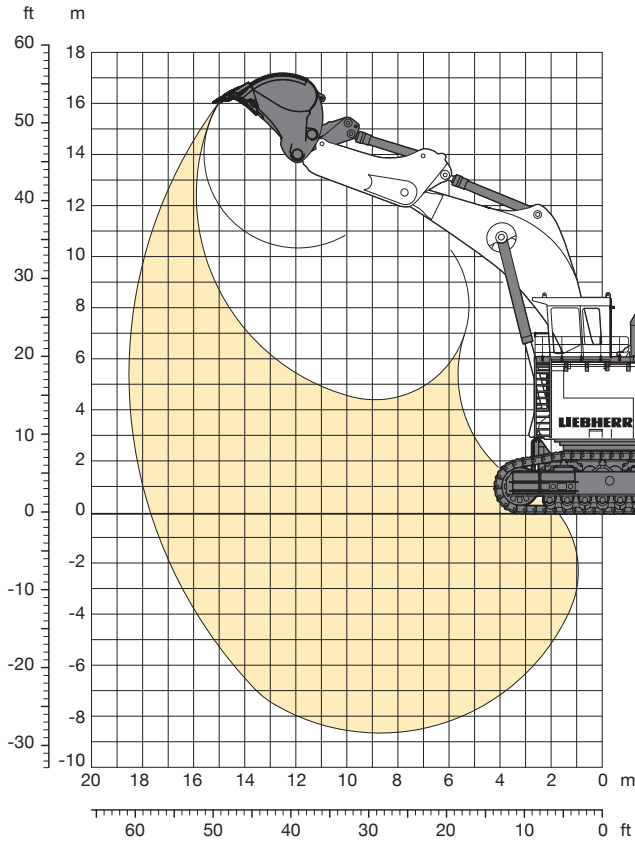

## Digging Envelope

|                            |                     |
|----------------------------|---------------------|
| Stick length               | 4.50 m/14'9"        |
| Max. reach at ground level | 17.80 m/58'4"       |
| Max. teeth height          | 16.30 m/53'5"       |
| Max. dump height           | 10.50 m/34'5"       |
| Max. digging depth         | 8.60 m/28'2"        |
| Max. digging force (SAE)   | 1150 kN/258,530 lbf |
| Max. breakout force (SAE)  | 1400 kN/314,733 lbf |

## Operating Weight and Ground Pressure

The operating weight includes the basic machine with backhoe attachment and a 26.50 m<sup>3</sup>/34.7 yd<sup>3</sup> bucket.

|                 |                          |                 |
|-----------------|--------------------------|-----------------|
| Pad width       | mm/ft in                 | 1,200/3'11"     |
| Weight          | kg/lb                    | 441,000/972,237 |
| Ground pressure | kg/cm <sup>2</sup> / psi | 2.47/35.13      |

## Buckets

| For materials classe according to VOB, Section C, DIN 18300 |                    | < 5    | < 5    | 5 – 6  | 5 – 6  | 5 – 6  | 7 – 8  |
|---|--------------------|--------|--------|--------|--------|--------|--------|
| Typical operation according to VOB, Section C, DIN 18300    |                    | GP     | GP     | HD     | HD     | HD     | XHD    |
| Capacity ISO 7451   | m <sup>3</sup>     | 28.00  | 25.00  | 28.00  | 26.50  | 24.00  | 24.00  |
|   | yd <sup>3</sup>    | 36.62  | 32.70  | 36.62  | 34.66  | 31.39  | 31.39  |
| Suitable for material up to a specific weight of            | t/m <sup>3</sup>   | 1.7    | 2.0    | 1.6    | 1.8    | 2.1    | 1.9    |
|   | lb/yd <sup>3</sup> | 2,867  | 3,373  | 2,698  | 3,035  | 3,541  | 3,204  |
| Cutting width   | mm                 | 4,300  | 4,300  | 4,300  | 4,300  | 4,300  | 4,250  |
|   | ft in              | 14'1"  | 14'1"  | 14'1"  | 14'1"  | 14'1"  | 13'11" |
| Weight  | kg                 | 30,000 | 27,500 | 32,000 | 30,100 | 27,600 | 29,500 |
|   | lb                 | 66,139 | 60,627 | 70,548 | 66,359 | 60,848 | 65,036 |

GP: General purpose bucket with Esco S110 teeth

HD: Heavy-duty bucket with Esco S110 teeth

XHD: Heavy-duty rock bucket with Esco S130 teeth

# Shovel Attachment

with Shovel Boom 7.60 m/24'9"

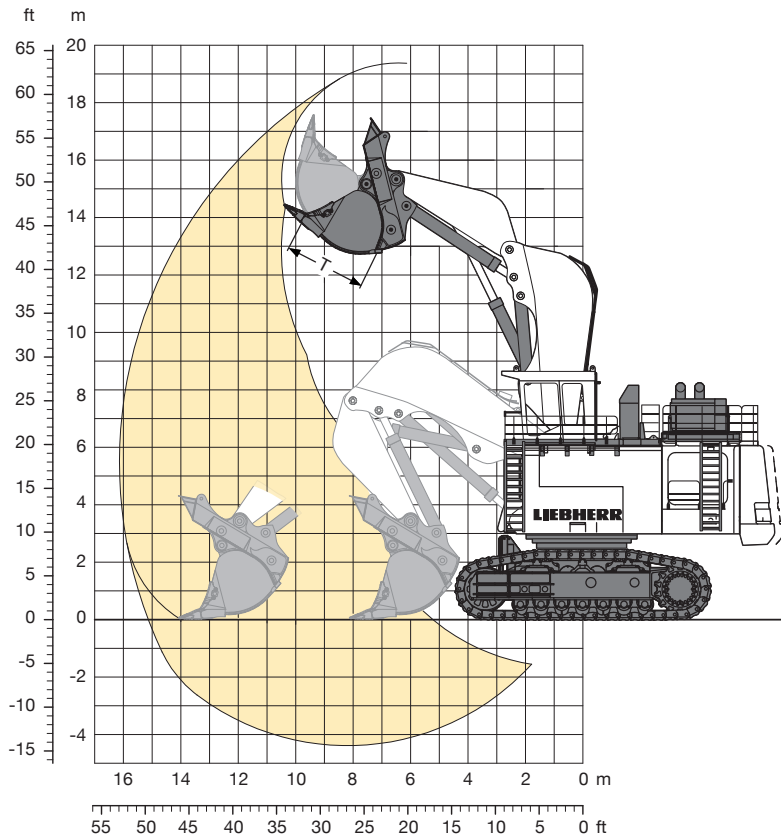

## Digging Envelope

|                                   |                      |
|-----------------------------------|----------------------|
| Stick length                      | 4.60 m/15' 1"        |
| Max. reach at ground level        | 15.15 m/49' 8"       |
| Max. dump height                  | 12.80 m/41'11"       |
| Max. crowd length                 | 6.00 m/19' 8"        |
| Bucket opening width T            | 2.80 m/ 9' 2"        |
| Crowd force at ground level (SAE) | 1,400 kN/314,733 lbf |
| Max. crowd force (SAE)            | 1,800 kN/404,656 lbf |
| Max. breakout force (SAE)         | 1,400 kN/314,733 lbf |

## Operating Weight and Ground Pressure

The operating weight includes the basic machine with shovel attachment and a 26.50 m<sup>3</sup>/34.7 yd<sup>3</sup> bucket.

|                 |                          |                 |
|-----------------|--------------------------|-----------------|
| Pad width       | mm/ft in                 | 1,200/3'11"     |
| Weight          | kg/lb                    | 450,000/992,079 |
| Ground pressure | kg/cm <sup>2</sup> / psi | 2.52/35.84      |

## Bottom Dump Buckets

| For materials classe according to VOB, Section C, DIN 18300 | < 5  | 5 – 6            | 5 – 6            | 7 – 8             |
|---|--|------------------|------------------|-------------------|
| Typical operation according to VOB, Section C, DIN 18300    | GP   | HD               | HD               | XHD               |
| Capacity ISO 7546   | m <sup>3</sup> 28.00<br>yd <sup>3</sup> 36.62    | 26.50<br>34.66   | 24.00<br>31.39   | 24.00<br>31.39    |
| Suitable for material up to a specific weight of            | t/m <sup>3</sup> 1.7<br>lb/yd <sup>3</sup> 2,867 | 1.8<br>3,035     | 2.0<br>3,373     | 1.9<br>3,204      |
| Cutting width   | mm 4,300<br>ft in 14'1"                          | 4,300<br>14'1"   | 4,300<br>14'1"   | 4,300<br>14'1"    |
| Weight  | kg 45,400<br>lb 100,090                          | 45,200<br>99,649 | 44,700<br>98,547 | 47,000<br>103,617 |
| Wear kit level  | I  | II               | II               | III               |

GP: General purpose bucket with Esco S110 teeth  
 HD: Heavy-duty bucket with Esco S110 teeth  
 XHD: Heavy-duty rock bucket with Esco S130 teeth

Level I: For non-abrasive materials, such as limestone, without flint inclusion, shot material or easily breakable rock, i.e., deteriorated rock, soft limestone, shale, etc.

Level II: For preblasted heavy rock, or deteriorated, cracked material (classification 5 to 6, according to DIN 18300)

Level III: For highly-abrasive materials such as rock with a high silica content, sandstone etc.

# Component Dimensions and Weights

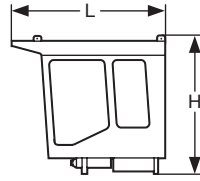

## Cab

|          |          |             |
|----------|----------|-------------|
| L Length | mm/ft in | 3,215/10'6" |
| H Height | mm/ft in | 2,885/ 9'5" |
| Width    | mm/ft in | 1,900/ 6'2" |
| Weight   | kg/lb    | 2,600/5,732 |

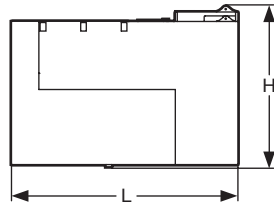

## Cab Elevation with Fuel Tank

|          |          |               |
|----------|----------|---------------|
| L Length | mm/ft in | 4,755/15' 7"  |
| H Height | mm/ft in | 3,400/11' 1"  |
| Width    | mm/ft in | 3,015/ 9'10"  |
| Weight   | kg/lb    | 10,250/22,597 |

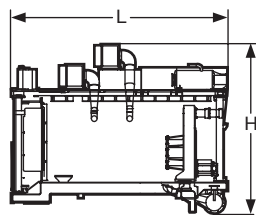

## Powerpack Modules

|          |          |               |
|----------|----------|---------------|
| L Length | mm/ft in | 5,720/18'9"   |
| H Height | mm/ft in | 4,500/14'9"   |
| Width    | mm/ft in | 2,650/ 8'8"   |
| Weight   | kg/lb    | 24,250/53,462 |

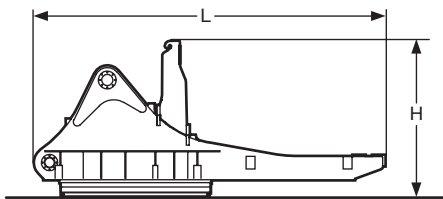

## Rotation Deck (with swing ring, swing gears and control valve bracket)

|          |          |                |
|----------|----------|----------------|
| L Length | mm/ft in | 8,700/28'6"    |
| H Height | mm/ft in | 3,900/12'9"    |
| Width    | mm/ft in | 4,000/13'1"    |
| Weight   | kg/lb    | 56,800/125,222 |

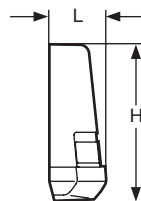

## Counterweight

|          |          |               |
|----------|----------|---------------|
| L Length | mm/ft in | 1,250/ 4' 1"  |
| H Height | mm/ft in | 3,430/11' 3"  |
| Width    | mm/ft in | 6,970/22'10"  |
| Weight   | kg/lb    | 44,000/97,003 |

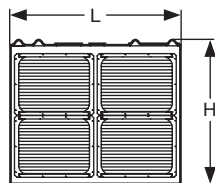

## Hydraulic Oil Cooling

|          |          |              |
|----------|----------|--------------|
| L Length | mm/ft in | 3,650/11'11" |
| H Height | mm/ft in | 3,150/10' 3" |
| Width    | mm/ft in | 2,100/ 6'10" |
| Weight   | kg/lb    | 7,700/16,976 |

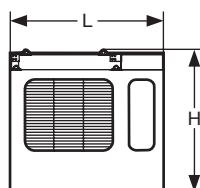

## Compartment Panel Right

|          |          |             |
|----------|----------|-------------|
| L Length | mm/ft in | 3,800/12'5" |
| H Height | mm/ft in | 3,500/11'5" |
| Width    | mm/ft in | 830/ 2'8"   |
| Weight   | kg/lb    | 1,500/3,307 |

# Component Dimensions and Weights

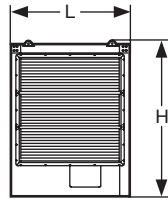

## Compartment Panel Left with Rotary Ladder

|          |          |              |
|----------|----------|--------------|
| L Length | mm/ft in | 2,650/ 8' 8" |
| H Height | mm/ft in | 3,500/11' 5" |
| Width    | mm/ft in | 860/ 2' 9"   |
| Weight   | kg/lb    | 1,800/3,968  |

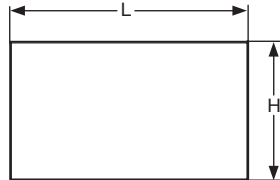

## Miscellaneous

|          |          |              |
|----------|----------|--------------|
| L Length | mm/ft in | 4,500/14'9"  |
| H Height | mm/ft in | 2,600/ 8'6"  |
| Width    | mm/ft in | 2,000/ 6'6"  |
| Weight   | kg/lb    | 5,000/11,023 |

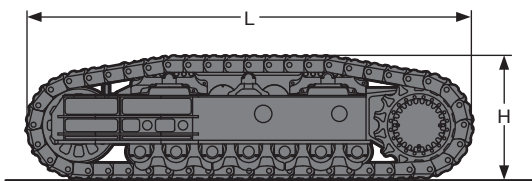

## Side Frame (two)

|                            |          |                        |
|----------------------------|----------|------------------------|
| L Length                   | mm/ft in | 8,800/28'10"           |
| H Height                   | mm/ft in | 2,500/ 8' 2"           |
| Width over travel drive    | mm/ft in | 1,800/ 5'10"           |
| Width without travel drive | mm/ft in | 1,650/ 5' 4"           |
| Weight                     | kg/lb    | 2 x 68,350/2 x 150,686 |

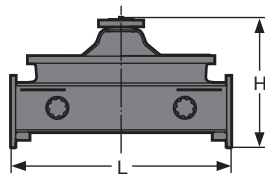

## Undercarriage Central Girder

|          |          |               |
|----------|----------|---------------|
| L Length | mm/ft in | 4,020/13'2"   |
| H Height | mm/ft in | 2,557/ 8'4"   |
| Width    | mm/ft in | 4,440/14'6"   |
| Weight   | kg/lb    | 34,200/75,398 |

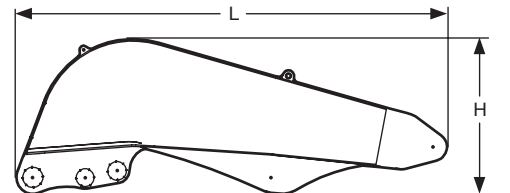

## Shovel Boom

|          |          |               |
|----------|----------|---------------|
| L Length | mm/ft in | 8,200/26'10"  |
| H Height | mm/ft in | 3,000/ 9'10"  |
| Width    | mm/ft in | 2,750/ 9'     |
| Weight   | kg/lb    | 38,000/83,776 |

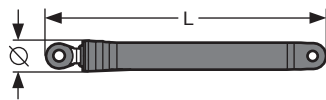

## Shovel Hoist Cylinder (two)

|            |          |                      |
|------------|----------|----------------------|
| L Length   | mm/ft in | 5,100/16'8"          |
| Ø Diameter | mm/ft in | 550/ 1'9"            |
| Weight     | kg/lb    | 2 x 5,000/2 x 11,023 |

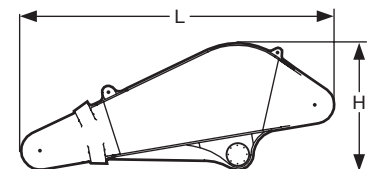

## Shovel Stick

|          |          |               |
|----------|----------|---------------|
| L Length | mm/ft in | 5200/17'      |
| H Height | mm/ft in | 2100/ 6'10"   |
| Width    | mm/ft in | 2300/ 7' 6"   |
| Weight   | kg/lb    | 20,300/44,754 |



# Component Dimensions and Weights

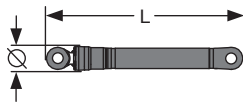

## Shovel Crowd Cylinder (two)

|            |          |                     |
|------------|----------|---------------------|
| L Length   | mm/ft in | 3,600/11'9"         |
| Ø Diameter | mm/ft in | 450/ 1'5"           |
| Weight     | kg/lb    | 2 x 2,000/2 x 4,409 |

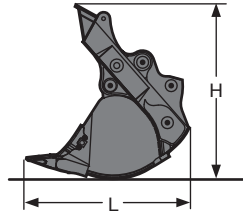

## Bottom Dump Bucket

|                   |                                 |               |
|-------------------|---------------------------------|---------------|
| Application       |                                 | HD            |
| Capacity ISO 7451 | m <sup>3</sup> /yd <sup>3</sup> | 26.5/34.66    |
| L Length          | mm/ft in                        | 4,650/15'3"   |
| H Height          | mm/ft in                        | 4,800/15'8"   |
| Width             | mm/ft in                        | 4,300/14'1"   |
| Weight            | kg/lb                           | 42,600/93,917 |

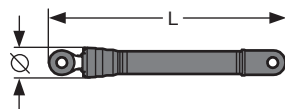

## Bucket Tilt Cylinder (two)

|            |          |                     |
|------------|----------|---------------------|
| L Length   | mm/ft in | 4300/14'1"          |
| Ø Diameter | mm/ft in | 520/ 1'8"           |
| Weight     | kg/lb    | 2 x 3,000/2 x 6,614 |

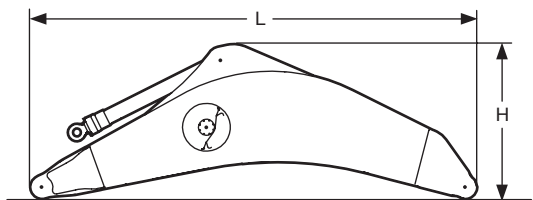

## Gooseneck Boom with Stick Cylinders

|          |          |               |
|----------|----------|---------------|
| L Length | mm/ft in | 10,600/34' 9" |
| H Height | mm/ft in | 4,100/13' 5"  |
| Width    | mm/ft in | 2,700/ 8'10"  |
| Weight   | kg/lb    | 44,300/97,665 |

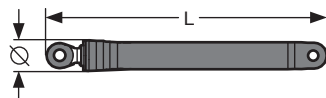

## Backhoe Hoist Cylinders (two)

|            |          |                      |
|------------|----------|----------------------|
| L Length   | mm/ft in | 5,100/16'8"          |
| Ø Diameter | mm/ft in | 550/ 1'9"            |
| Weight     | kg/lb    | 2 x 4,900/2 x 10,800 |

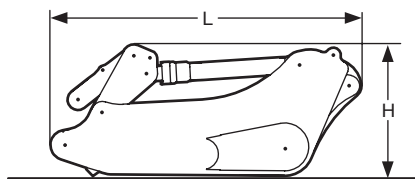

## Stick with Bucket Cylinders

|          |          |               |
|----------|----------|---------------|
| L Length | mm/ft in | 6400/20'11"   |
| H Height | mm/ft in | 2200/ 7' 2"   |
| Width    | mm/ft in | 2150/ 7'      |
| Weight   | kg/lb    | 27,500/60,627 |

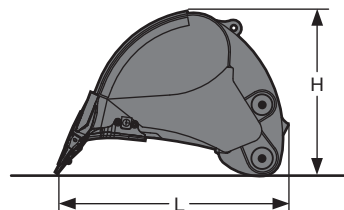

## Backhoe Bucket

|                   |                                 |               |
|-------------------|---------------------------------|---------------|
| Application       |                                 | HD            |
| Capacity ISO 7451 | m <sup>3</sup> /yd <sup>3</sup> | 26.5/34.66    |
| L Length          | mm/ft in                        | 4,300/14'1"   |
| H Height          | mm/ft in                        | 3,200/10'5"   |
| Width             | mm/ft in                        | 4,300/14'1"   |
| Weight            | kg/lb                           | 30,220/66,624 |

All illustrations and data may differ from standard equipment. Subject to change without notice. All indicated loads are based in accordance with ISO 9248.

# The Liebherr Group of Companies

## Wide product range

The Liebherr Group is one of the largest construction equipment manufacturers in the world. Liebherr's high-value products and services enjoy a high reputation in many other fields, too. The wide range includes domestic appliances, aerospace and transportation systems, machine tools and maritime cranes.

## Exceptional customer benefit

Every product line provides a complete range of models in many different versions. With both their technical excellence and acknowledged quality, Liebherr products offer a maximum of customer benefits in practical application.

## State-of-the-art technology

To provide consistent, top quality products, Liebherr attaches great importance to each product area, its components and core technologies. Important modules and components are developed and manufactured in-house, for instance the entire drive and control technology for construction equipment.

## Worldwide and independent

Hans Liebherr founded the Liebherr family company in 1949. Since that time, the enterprise has steadily grown to a group of more than 100 companies with over 32,000 employees located on all continents. The corporate headquarters of the Group is Liebherr-International AG in Bulle, Switzerland. The Liebherr family is the sole owner of the company.

[www.liebherr.com](http://www.liebherr.com)



Printed in Germany by Typodruck RG-BK-RP LFR/SP 11003232-1-03.10\_enGB-US

## Liebherr-France SAS Mining Division

49 rue Frédéric Hartmann, CS 50038, F-68025 Colmar Cedex

☎ +33 369 4921 99, Fax +33 369 4922 79

[www.liebherr.com](http://www.liebherr.com), E-Mail: [info.lfr-mining@liebherr.com](mailto:info.lfr-mining@liebherr.com)