

**Kawasaki**

**70TMV-2**

174HP | 3.2-3.6 yd<sup>3</sup> BUCKET CAPACITY



# RUGGED AND DEPENDABLE

## A COMPLETE SOLUTION

- ▶ Emissions-compliant 174 HP Cummins diesel engine
- ▶ 3.2 to 3.6 cu. yard bucket available
- ▶ Accepts a wide assortment of attachments to handle many jobs
- ▶ Ride Control option provides stable load handling
- ▶ Single hydraulic control option for easy operation
- ▶ Automatic powershift transmission with four forward and reverse speeds
- ▶ Outboard-mounted, dual circuit wet disc brakes for reliability and long service life
- ▶ Torque-proportioning differentials for longer tire life and less wheel spin
- ▶ Transmission has helical gears which reduce noise level and vibration
- ▶ Engine cooling system with hydraulic fan for efficient cooling
- ▶ Adjustable declutch allows the operator to adjust the declutch to various operating conditions
- ▶ Air conditioning, standard
- ▶ MODM (Machine Operation Diagnostic Module) provides essential operations and diagnostic information in an easy-to-read LCD display

**EASY TO OPERATE.  
EASY TO MAINTAIN.  
EASY TO DO BUSINESS WITH.**

## POWER TO SPARE.

The 70TMV-2 features a redesigned ROPS cab with operator-friendly features. The operator may now customize settings and make adjustments to the loader controls to work more efficiently in the current operating conditions or environment. New features like the Adjustable Declutch, Dual Boom Kickout Control, Idle Management System, and Dual Mode Engine Switch, allow the operator to make adjustments from the comfort of the cab increasing productivity and efficiency. Options such as the Limited Slip Differentials and ELS (Efficient Loading System) allow the operator additional controls to adapt the 70TMV-2 loader to the working conditions.



## COMFORTABLE, EFFICIENT, SAFE.

The 70TMV-2 features standard air conditioning and heater. The Air Ride seat is standard. The operator compartment has increased leg room. Options such as the F-R Directional Switch, Ride control, and Single Lever Hydraulic Control allow the operator additional ease of operation and comfort.

## VERSATILE, RELIABLE, STRONG.

Like all Kawasaki loaders, the 70TMV-2 has a 45+ year heritage of strength and reliability.

The 70TMV-2 is available with several buckets, bucket teeth, and bolt-on cutting edge combinations. A third spool valve is available to handle a number of attachments and extend the wheel loader's versatility.

Features such as the outboard-mounted, sealed wet disc brakes are designed for long life and easy access and overhaul. Spin-on filters, grouped grease fittings, sealed universal joints, hinged hydraulic oil cooler, all provide easy field maintenance. The new MODM (Machine Operation Diagnostic Module) provides essential operational and diagnostic information in an easy-to-read LCD display. The optional K-LINK system allows location, system alarm sensors, and all major machine performance data to be electronically transmitted to cell phones, fax and e-mail for real-time equipment management.

## FAILURE IS NOT AN OPTION.

Kawasaki is dedicated to keeping your wheel loader up and running, even in the most challenging situations. Starting with the KLEW (Kawasaki Loaders Early Warning) Oil Analysis System, designed to eliminate unnecessary maintenance and downtime, to our 24-hour parts shipment service, and our extensive rebuild program, Kawasaki has the expertise and experience to respond quickly to your needs.



*Kawasaki and their dealer organization offer comprehensive support and service programs designed to keep you on the job.*

# POWER AND PERFORMANCE PROVIDE UNMATCHED PRODUCTIVITY



## COMPUTER CONTROLLED ENGINE

The Engine Control Module (ECM) provides a wide range of operating data and feedback to assist in analyzing diagnostics and troubleshooting. Cummins offers diagnostic tools to allow technicians to quickly recover engine information for fast, accurate analysis.

EPA Tier III emission standards are met by using the Cummins In-Cylinder Advanced Combustion Solution, a proven technology that keeps the overall design simple and less costly to maintain.

- Extended Oil Change intervals
- Increased Peak Torque provides improved performance, better rimpull.
- Reduced RPM reduces fuel consumption without loss of operating efficiency.
- Idle Management System allows for lower engine speed when idling for extended periods to conserve fuel. It also increases engine RPM to reduce engine warm-up time in cold temperatures.

## WORLD-CLASS ENGINES

- 174 HP Cummins QSB6.7 diesel
- Complies with tough Tier III emissions standards
- Engineered for longer service life
- Reliable and fuel efficient
- Extensive distribution system
- 24 volt battery system for reserve power
- Turbocharger with aftercooler

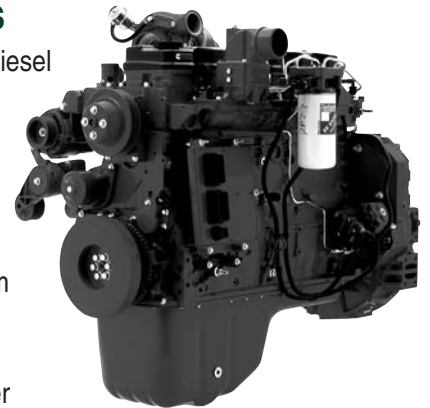

## FUEL EFFICIENT MODE



The operator can select either “Power” or “Fuel Efficient” engine mode. Power mode provides added power for extreme applications. Fuel Efficient mode offers better fuel economy for standard applications.

## HIGH EFFICIENCY HYDRAULIC SYSTEM

- Dry, reliable
- Cast iron, dirt tolerant, gear pumps
- Easy access to two-spool control valve
- Large oil reservoir keeps oil cooler

## TRANSMISSION

- Automatic transmission selects optimum speed from second to fourth gear
- Single lever control
- Switch activates adjustable transmission declutch on the left brake pedal **1**
- Transmission declutch can be set by the operator to match operating conditions
- Downshift button speeds cycle times and reduces operator fatigue
- Helical gears reduce noise and vibration

## AXLES/BRAKES

- Torque Proportioned Differentials improve traction in slippery conditions
- 23.5 x 25-16PR (L-3) tires standard
- 20.5 x 25-12PR (L-3) 23.5 x 25-12PR (L-2, L-3 and radial) tires available
- 650/65R25XLD low profile tires available
- 3-piece rims standard **2**
- Outboard-mounted, dual-circuit wet disc brakes **3**
- Easy maintenance
- High capacity
- Long life

## LIFT ARMS/BUCKETS

- Parallel Linkage keeps loads level throughout lift cycle
- High breakout force
- 3.2 to 3.6 cu. yd. buckets
- Easy loading
- Excellent load retention
- Full assortment of edges and teeth
- Complete array of attachments available

## ECONOMIC AND EFFICIENT SYSTEMS

- Hydraulic System, designed for energy efficiency with the steering flow to supplement the main circuit once steering demand is met. This allows for full utilization of the pump capacity for efficient operation in all conditions.
- Adjustable Boom Kickout can be set by the operator to attain proper dump height and return-to-dig height **4**
- Automatic 4-speed transmission, single grip shift lever
- Bucket leveler and boom kick-out standard

## STRUCTURED TO LAST

- Redesigned buckets provide easy loading and excellent load retention
- Full assortment of edges and teeth
- Complete array of attachments available
- Massive center pins and bearings **5**
- Heavy box frame rear chassis **6**

5



4



3

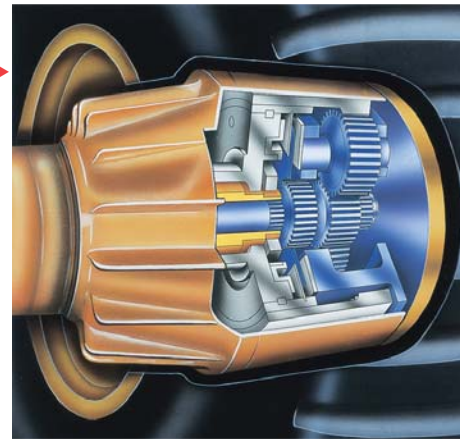

2

1



6

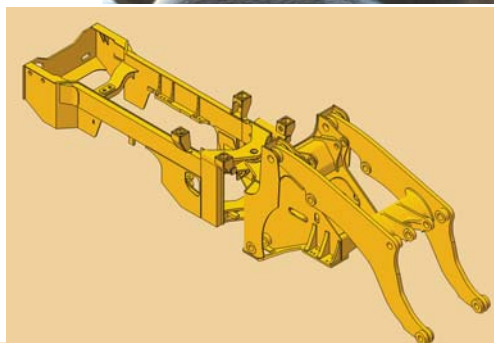

# THE COMFORT ZONE



## ENJOY THE RIDE

- The cab provides excellent visibility in all directions **1**
- The front windshield is flat glass mounted in rubber gaskets that make windshield replacement fast and easy.
- Viscous mounting of the cab reduces vibration and noise
- Fully certified ROPS/FOPS cab meets all regulations
- Increased Leg Room
- Air Conditioning, standard
- Air Ride Seat, standard **2**
- Tilting and Telescopic Steering column
- Easy access to cab on both sides of machine
- Sliding side windows
- AM/FM Cassette Radio, standard
- Increased personal storage and climate controlled storage box
- Front and Rear window wipers and washers



## TOTAL COMMAND. TOTAL CONTROL.

- MODM (Machine Operation Diagnostic Module) offers information to make the operation, maintenance and troubleshooting more efficient. With this information, operators, maintenance and technical personnel can quickly determine key operating data. **3**
- Downshift Button, located on the boom control lever provides quick, convenient downshifting from 2nd gear to 1st gear.
- Adjustable Declutch allows the operator to select the location of the left brake pedal where the declutch engages. This allows the operator to adjust for varying operating conditions easily.
- 12V outlet for operator to use 2-way radios and other plug-in devices



## ACCESSIBILITY, SERVICEABILITY, DURABILITY

- Sealed universal joints only require greasing at 12,000 hour intervals extending the life expectancy of the drive shaft
- Easy engine access with gull wing engine panels and side door opening.
- Easy access to filters, drains and fittings
- MODM (Machine Operation Diagnostic Module) offers information to make the operation, maintenance and troubleshooting more efficient. With this information, operators, maintenance and technical personnel can quickly determine key operating data.
- Hinged Hydraulic Oil Cooler allows for easier cleaning and maintenance.
- Increased Transmission Capacity provides greater service life
- Outboard Wet Disc Brakes, sealed, provide high capacity braking and protection from contamination. The dual brake system separates the front and rear axles for added safety.
- Sealed Deutsch DT electrical connectors are used throughout the system to reduce corrosion and improve durability
- JRB Quick Coupler and Attachments



## OPTIONS

### OPTIONAL EQUIPMENT

- ELS—Efficient Loading System, increases rimpull power when digging while demanding less fuel. Increases productivity and fuel efficiency. A switch on the instrument control panel allows operator to activate from cab. **1**
- Limited Slip Differentials provide additional traction for applications requiring extreme traction control. **2**
- F-R Directional Switch allows the operator to select direction directly from the side console. **3**
- Ride Control offers a smooth ride to improve load retention and increase travel speeds. **4**
- HID (High Intensity Discharge) lights are extremely bright lights with exceptionally long service life.

- K-Link, a management tool, provides on demand reports on machine location, hours, system sensors, engine performance, operating status, geo-fence break alerts and several customizable reports by phone, pager, or e-mail
- Single Lever Hydraulic Control increases operator efficiency
- Third spool hydraulic attachments

### SPECIAL APPLICATION PACKAGES

- Logging/Woodchip **1**
- Waste/Refuse/Recycling **2**

Without Ride Control

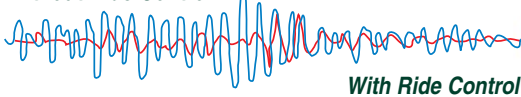

With Ride Control



**3**



**2**

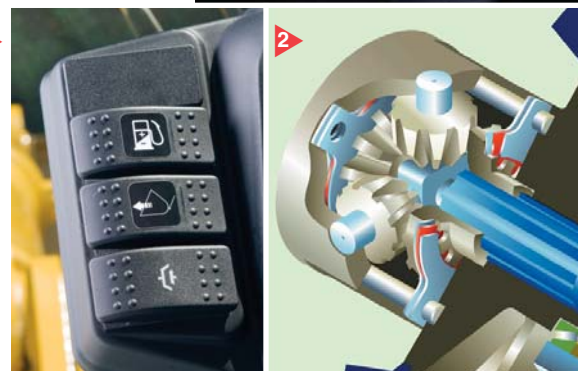

**1**

## OPERATING SPECIFICATIONS

ENGINE	
Gross Power (SAE J1995)	193 HP/2200 RPM
Net Power (SAE J1349)	174 HP/2200 RPM
Net Peak Torque	657 lb.-ft./1400RPM
Make/Model/Fuel Type	Cummins/QSB6.7/Diesel
Type	4-cycle, watercooled, in-line direct injection type with turbo charger and air-cooled intercooler
Number of cylinders	6
Bore and stroke	4.2" x 4.8" (107mm x 124mm)
Total displacement	409 in <sup>3</sup> (6.7 L)
Alternator	AC24V – 1.7kw (70amp)
Battery	12V – 150AH, 2 units

TORQUE CONVERTER AND TRANSMISSION		
Torque converter	3 elements, single stage	
Torque stall ratio	2.96:1	
Main clutches	Wet hydraulic, multi-disc type	
Cooling method	Forced circulation type	
Transmission	Full power shift, 4 forward, 4 reverse with automatic mode (2nd–4th) with downshift switch for 2nd–1st downshifting	
Speeds	Forward	1st: 5.0 MPH (8.0 km/hr) 2nd: 8.3 MPH (13.4 km/hr) 3rd: 13.7 MPH (22.0 km/hr) 4th: 23.4 MPH (37.6 km/hr)
	Reverse	1st: 5.1 MPH (8.2 km/hr) 2nd: 8.5 MPH (13.7 km/hr) 3rd: 13.9 MPH (22.4 km/hr) 4th: 23.6 MPH (38.0 km/hr)

SYSTEMS CAPACITY		
LOCATION	Gallons	Liters
Engine (coolant)	7.9	(30.0)
Fuel tank (diesel fuel)	71.3	(270.0)
Engine (oil pan)	6.3	(24.0)
Front axle (gear oil)	13.2	(50.0)
Rear axle (gear oil)	13.7	(52.0)
Torque converter and transmission (engine oil)	11.9	(45.0)
Hydraulic system including tank (hydraulic oil)	44.9	(170.0)

HYDRAULIC AND STEERING SYSTEM		
Steering type	Articulated frame steering	
Steering mechanism	Hydraulic power steering unit, direct type	
Lift (boom) cylinder	Two (2) double-acting piston type: 5.5" x 29.7" (140mm x 754mm)	
Tilt (bucket) cylinder	One (1) double-acting piston type: 6.3" x 20.1" (160mm x 511mm)	
Steering cylinder	Two (2) double-acting piston type: 3.1" x 15.0" (80mm x 380mm)	
Main oil pump	Gear type: 18.2 GPM @ 2200 RPM (69 LPM @ 2200 RPM)	
Steering oil pump	Gear type: 46.2 GPM @ 2200 RPM (175 LPM @ 2200 RPM)	
Pilot oil pump	Gear type: 18.2 GPM @ 2200 RPM (69 LPM @ 2400 RPM)	
Relief valve set pressure	Loading	3000 psi (210 kg/cm <sup>2</sup> )
	Steering	3000 psi (210 kg/cm <sup>2</sup> )
HYDRAULIC CYCLE TIME*		
Lifting time (at full load)	5.9 sec.	
Lowering time (empty)	3.1 sec.	
Bucket dumping time	1.9 sec.	
TOTAL	10.9 sec.	

\* Measured in accordance with SAE J732C

AXLE SYSTEM		
Drive system	4-wheel drive	
Front and rear axle	Full floating banjo type	
Tires	Standard	23.5 x 25-16PR (L-3)
	Optional	20.5 x 25-12PR (L-2) 20.5 x 25-12PR (L-3) 23.5 x 25-12PR (L-3) 650/65R25 Low Profile
Reduction and differential gear	Spiral bevel/gear, 1 stage reduction torque, proportioning type	
Final reduction gear	Outboard mounted. Internal planetary gear	
Oscillation angle	±11° (total 22°)	

BRAKE SYSTEM	
Service brakes	4 wheel, adjustment free, wet multiple disc brake. Controlled by full hydraulic system. Dual circuit.
Parking/Emergency brake	Spring applied oil pressure released type. Meets MSHA requirements.



## OPERATING SPECIFICATIONS

### WEIGHTS AND DIMENSIONS (SUPPLEMENTAL DATA)

		Operating Weight	Tipping Load			Overall Width (Outside Tire)	Tread	Vertical Dimensions	Overall Length
			Straight	Full Turn					
ROPS Canopy (Instead of ROPS Cab)	lb (kg)	-298 (-135)	-331 (-150)	-265 (-120)	in (mm)				
Remove ROPS Cab (for transport only)	lb (kg)	-1,100 (-500)			in (mm)			-10' 15/16" (-275)	
Remove Optional Counterweight	lb (kg)	-770 (-350)	-1,760 (-800)	-1,540 (-700)	in (mm)				
Tires: 20.5-25-12PR (L-2)	lb (kg)	-1,792 (-813)	-1,344 (-609)	-1,174 (-533)	in (mm)	-2" (-50)	-1 9/16" (-40)	-3" (-76)	+2 1/8" (+55)
20.5-25-12PR (L-3)	lb (kg)	-1,753 (-795)	-1,314 (-596)	-1,148 (-521)	in (mm)	-2" (-50)	-1 9/8" (-40)	-2 3/8" (-60)	+2" (+50)
23.5-25-12PR (L-3)	lb (kg)	-152 (-69)	-114 (-85)	-100 (-45)	in (mm)				
650/65R25 Low Profile	lb (kg)	+396 (+180)	+321 (+145)	+292 (+135)	in (mm)				
Air conditioner (Deletion)	lb (kg)	-220 (-100)	-240 (-110)	-210 (-95)	in (mm)				
Belly Guard (rear frame)	lb (kg)	+236 (+130)	+352 (+160)	+308 (+140)	in (mm)				

Base Tire 23.5-25-16PR (L-3)

Tread ..... 6'10 11/16" (2,100mm)  
 Width (outside tire) ..... 8'7 23/32" (2,635mm)  
 Width (outside bucket) ..... 8'9 1/8" (2,670mm)  
 Equipped with quick coupler, GSC bucket with bolt on cutting edge, 23.5-25-16PR (L-3) tire and ROPS Cab

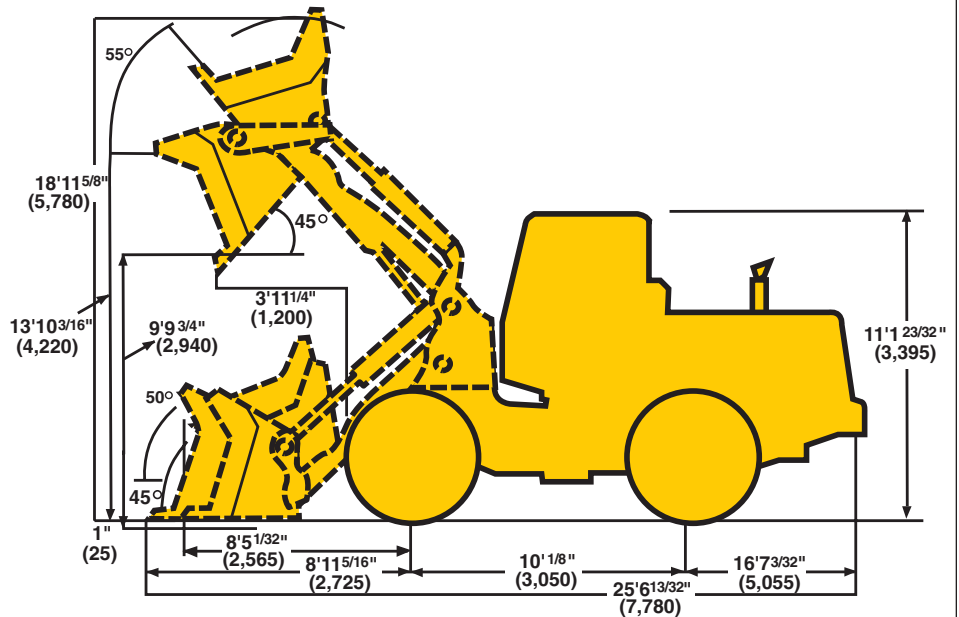

### BUCKET SELECTION CHARTS

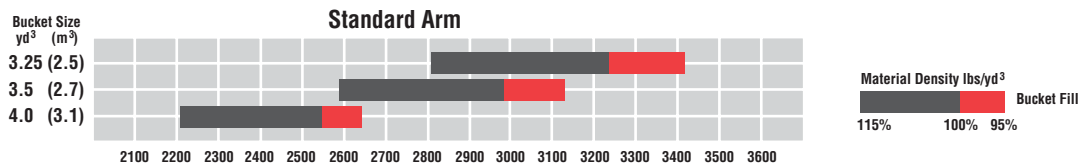

## BUCKET DATA

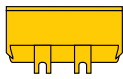
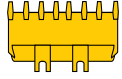
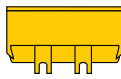
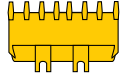
			General Purpose		Pin On	
			QGSC	QGST	GSC	GST
						
Capacity	Heaped	yd <sup>3</sup> (m <sup>3</sup> )	3.4 (2.6)	3.2 (2.4)	3.6 (2.8)	3.4 (2.6)
	Struck	yd <sup>3</sup> (m <sup>3</sup> )	3.1 (2.3)	2.9 (2.2)	3.3 (2.5)	3.1 (2.3)
Maximum dumping clearance		ft-in (mm)	9'9 <sup>3</sup> / <sub>4</sub> " (2,990)	9'6 <sup>3</sup> / <sub>16</sub> " (2,900)	10'2 <sup>9</sup> / <sub>32</sub> " (3,070)	9'9 <sup>5</sup> / <sub>32</sub> " (2,975)
Dumping reach (to front of bucket edge or tooth)		ft-in (mm)	3'11 <sup>1</sup> / <sub>4</sub> " (1,200)	4'1 <sup>5</sup> / <sub>8</sub> " (1,260)	3'8 <sup>5</sup> / <sub>16</sub> " (1,125)	3'10 <sup>7</sup> / <sub>8</sub> " (1,190)
Bucket hinge pin height		ft-in (mm)	13'10 <sup>9</sup> / <sub>16</sub> " (4,220)	13'10 <sup>9</sup> / <sub>16</sub> " (4,220)	13'10 <sup>9</sup> / <sub>16</sub> " (4,220)	13'10 <sup>9</sup> / <sub>16</sub> " (4,220)
Digging depth		ft-in (mm)	1 <sup>3</sup> / <sub>8</sub> " (35)	1 <sup>31</sup> / <sub>32</sub> " (50)	1 <sup>3</sup> / <sub>8</sub> " (35)	1 <sup>31</sup> / <sub>32</sub> " (50)
Breakout force		lb (kg)	29,300 (13,290)	31,500 (14,290)	31,770 (14,410)	34,370 (15,590)
Bucket tilt-back angle	at ground level		43°	43°	43°	43°
	at carry position		52°	52°	52°	52°
Overall	Length	ft-in (mm)	25'10 <sup>11</sup> / <sub>32</sub> " (7,780)	25'5 <sup>13</sup> / <sub>16</sub> " (7,765)	25'11 <sup>1</sup> / <sub>16</sub> " (7,660)	25'6" (7,770)
	Height	ft-in (mm)	11'1 <sup>23</sup> / <sub>32</sub> " (3,395)	11'1 <sup>23</sup> / <sub>32</sub> " (3,395)	11'1 <sup>23</sup> / <sub>32</sub> " (3,395)	11'1 <sup>23</sup> / <sub>32</sub> " (3,395)
	Width (outside tire)	ft-in (mm)	8'6" (2,590)	8'6" (2,590)	8'6" (2,590)	8'6" (2,590)
	Width (outside bucket)	ft-in (mm)	8'9 <sup>5</sup> / <sub>32</sub> " (2,670)	8'9 <sup>5</sup> / <sub>32</sub> " (2,670)	8'9 <sup>5</sup> / <sub>32</sub> " (2,670)	8'9 <sup>5</sup> / <sub>32</sub> " (2,670)
Wheel base		ft-in (mm)	10'1 <sup>1</sup> / <sub>8</sub> " (3,050)	10'1 <sup>1</sup> / <sub>8</sub> " (3,050)	10'1 <sup>1</sup> / <sub>8</sub> " (3,050)	10'1 <sup>1</sup> / <sub>8</sub> " (3,050)
Minimum turning radius	at outside bucket	ft-in (mm)	20'2 <sup>19</sup> / <sub>32</sub> " (6,160)	19'9 <sup>19</sup> / <sub>32</sub> " (6,205)	20'1 <sup>9</sup> / <sub>32</sub> " (6,110)	20'2 <sup>19</sup> / <sub>32</sub> " (6,160)
	at center of outside tire	ft-in (mm)	17'1 <sup>19</sup> / <sub>32</sub> " (5,220)	17'1 <sup>19</sup> / <sub>32</sub> " (5,220)	17'1 <sup>19</sup> / <sub>32</sub> " (5,220)	17'1 <sup>19</sup> / <sub>32</sub> " (5,220)
Minimum ground clearance		ft-in (mm)	1'5 <sup>29</sup> / <sub>32</sub> " (445)	1'5 <sup>29</sup> / <sub>32</sub> " (445)	1'5 <sup>29</sup> / <sub>32</sub> " (445)	1'5 <sup>29</sup> / <sub>32</sub> " (445)
Full articulation angle		degree	40°	40°	40°	40°
Operating weight (with ROPS Cab)		lb (kg)	35,566 (16,132)	35,346 (16,033)	35,056 (15,901)	34,836 (15,801)
Static tipping load (with ROPS Cab)	Straight	lb (kg)	23,170 (10,510)	23,390 (10,610)	23,635 (10,720)	23,855 (10,820)
	Full turn	lb (kg)	19,840 (9,000)	20,040 (9,090)	20,240 (9,180)	20,415 (9,260)

The weight and load figure includes counterweight, air conditioner, enclosed ROPS cab, hydraulic coupler, 23.5-25-16PR (L-3) tires, full fuel tank and operator.

Materials and specifications are subject to change without notice and without obligation on the part of the manufacturer. The specifications supplied, while believed to be completely reliable, are not to be taken as warranty for which we assume legal responsibility.

## ATTACHMENT DATA

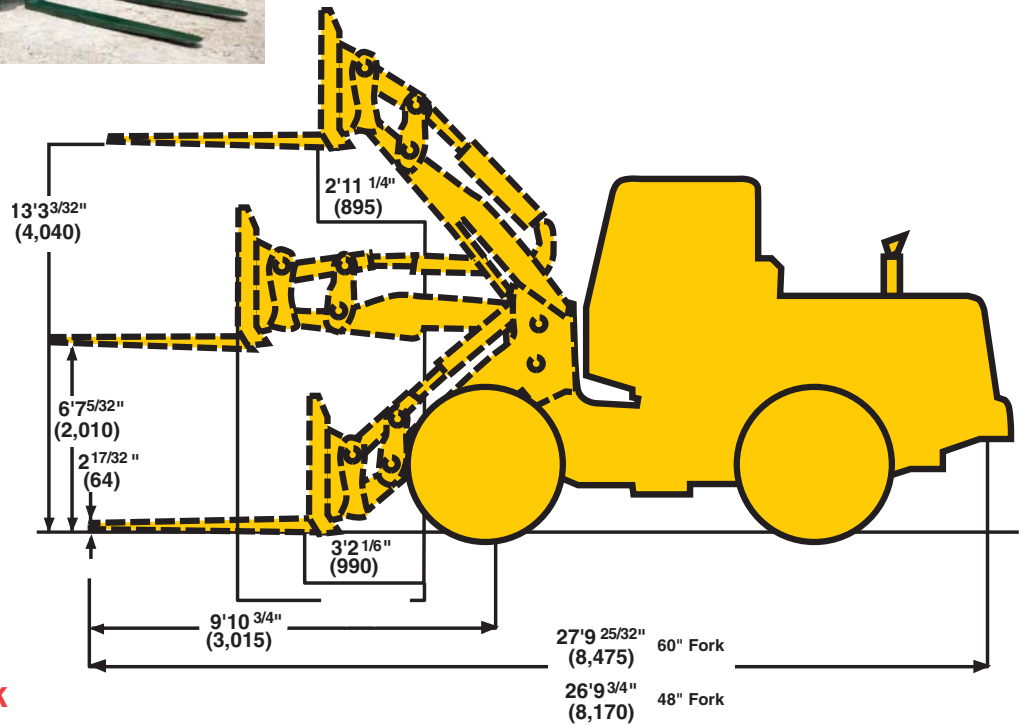

### Construction Utility Fork

SPECIFICATIONS WITH FORKS			
Fork Tine length		48"	60"
Ground to top of tine clearance	ft-in (mm)	13'3 <sup>3</sup> / <sub>32</sub> " (4,040)	13'3 <sup>3</sup> / <sub>32</sub> " (4,040)
Reach with arms horizontal and forks level	ft-in (mm)	9'10 <sup>17</sup> / <sub>32</sub> " (3,010)	10'10 <sup>9</sup> / <sub>16</sub> " (3,315)
Overall Length	ft-in (mm)	26'9 <sup>3</sup> / <sub>4</sub> " (8,170)	27'9 <sup>25</sup> / <sub>32</sub> " (8,475)
Static tipping load with level arms and forks, load center <b>straight</b>	lb (kg)	24,095 (10,930)	22,510 (10,210)
Static tipping load with level arms and forks, load center <b>full 40° turn</b>	lb (kg)	20,635 (9,360)	19,280 (8,745)
Operating weight*	lb (kg)	33,750 (15,310)	33,850 (15,353)
Attachment weight with 60" carriage	lb (kg)	1,475 (670)	1,571 (713)

The weight and load figure includes counterweight, air conditioner, enclosed ROPS cab, hydraulic coupler, 23.5-25-16PR (L-3) tires, full fuel tank and operator.

## ATTACHMENT DATA

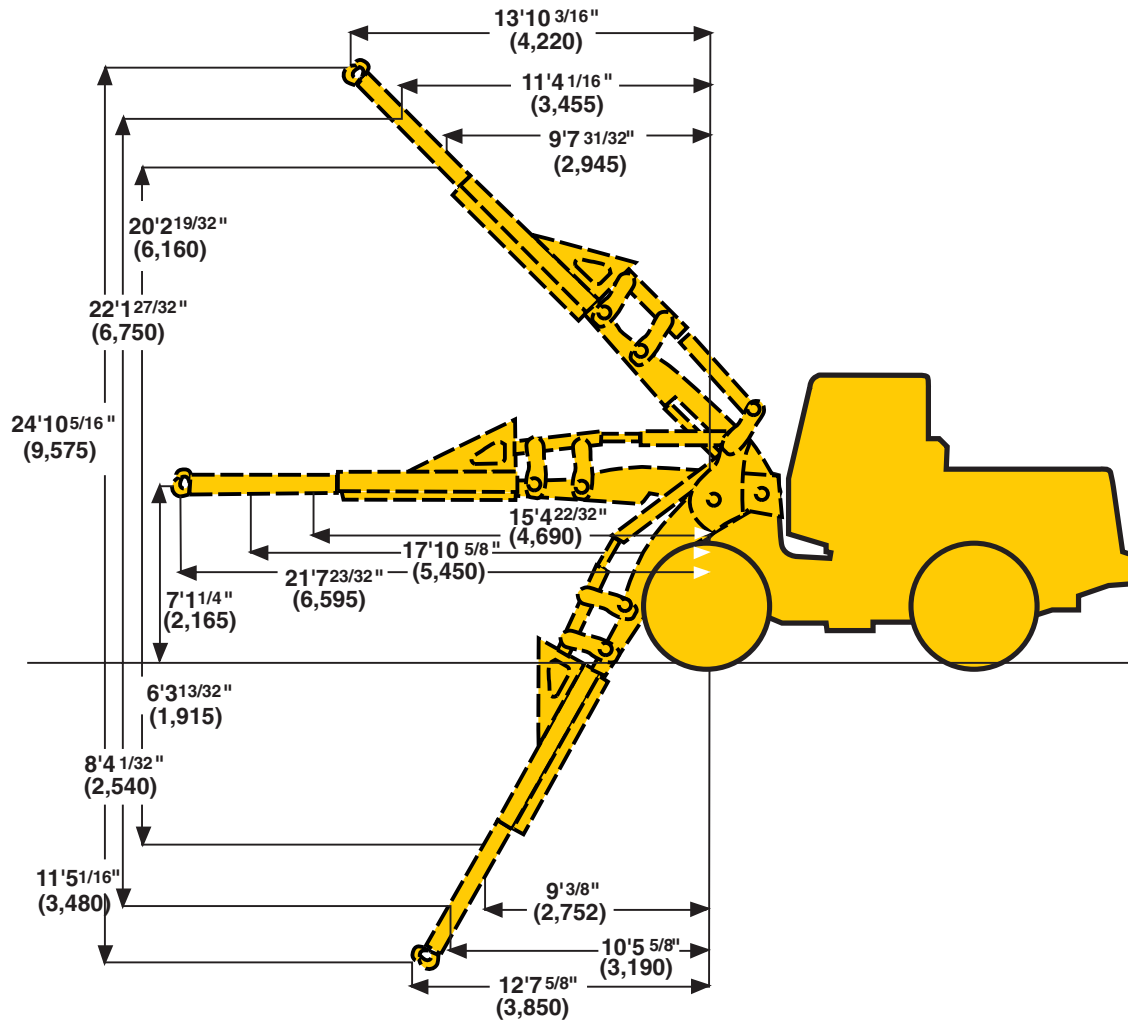

### Extendable Boom

SPECIFICATIONS WITH EXTENDABLE BOOM					
Boom position			Retracted	Mid-Position	Extended
Operating load at 40° articulation		lb (kg)	5,290 (2,400)	4,530 (2,055)	3,425 (1,690)
Static tipping load*	Full 40° turn	lb (kg)	10,580 (4,800)	9,060 (4,110)	7,450 (3,380)
	Straight	lb (kg)	12,355 (5,605)	10,580 (4,800)	8,710 (3,950)
Operating weight*		lb (kg)	33,445 (15,170)	33,445 (15,170)	33,445 (15,170)
Attachment weight		lb (kg)	1,107 (531)	1,107 (531)	1,107 (531)

The weight and load figure includes counterweight, air conditioner, enclosed ROPS cab, hydraulic coupler, 23.5-25-16PR (L-3) tires, full fuel tank and operator.

## EQUIPMENT DATA

STANDARD EQUIPMENT			
<p>Air Conditioner (R134 Refrigerant)</p> <p>Alarms (Audible):            Brake Oil Pressure            Engine Oil Pressure            Hydraulic Oil Level</p> <p>Alarms (Visual):            Air Filter            Battery Discharge            Brake Oil Pressure            Central Warning Lamp            Engine Coolant Temperature            Engine Oil Pressure            Engine Warning            Hydraulic Oil Level            Parking Brake            Torque Converter Oil Temperature            Transmission Control Warning</p> <p>Alternator (70 amp)            AM/FM Cassette Radio            Batteries: 12V-150AH (2 units)            Bellyguard, Engine            Brake Line Protection (Front)            Brake (Parking)            Spring applied; Oil pressure released, Drum Type</p>	<p>Brakes (Service)            Enclosed Wet Disc, Dual System            Full Hydraulic System</p> <p>Bucket Control Lever            Dual, Pilot Assisted</p> <p>Bucket Leveler</p> <p>Boom Kickout (2-Position, Adjustable, In Cab)</p> <p>Coat Hook</p> <p>Cold Start Aid</p> <p>Converter, 12V/10Amp dash outlet</p> <p>Counterweight, Bucket</p> <p>Coupler, Hydraulic w/Lines &amp; Control</p> <p>Cup Holder</p> <p>Downshift Button</p> <p>Drawbar</p> <p>Engine Pre-Cleaner, Full-View</p> <p>Fenders (Front and Rear)</p> <p>Gauges:            Converter Oil Temperature            Engine Coolant Temperature            Fuel Level            Hour Meter            Hydraulic Oil Level, Sight            Tachometer</p>	<p>Heater/Pressurizer (40,000 BTU)</p> <p>Hoodsides (Hinged)</p> <p>Horn (Electric)</p> <p>Hydraulic Fan (Variable, Blower)</p> <p>Indicators:            Engine Pre-Heater            High Beam            Parking Brake            Transmission Declutch            Transmission Shift Monitor            Working Light</p> <p>Linkage (Parallel, Sealed)</p> <p>Lights:            2 Headlights (Hi/Lo/Halogen)            4 Forward Working Lights            4 Rear Working Lights            2 Stop/Tail/Backup (LED)</p> <p>MODM (Machine Operation Diagnostic Module)</p> <p>Muffler</p> <p>Neutral Safety Start</p> <p>Operator's Manual Box</p> <p>Quick Coupler</p> <p>Radiator:            Corrugated Fin Type</p>	<p>Radiator Grille, Hinged</p> <p>Reverse Alarm</p> <p>ROPS Cab: Enclosed cab with sound suppression, 2-front Work lights, front and rear wipers and washers, two rear view and side mirrors, tinted glass, sliding side windows, and 2-rear Work lights</p> <p>Safety Articulation Locking Bar</p> <p>Seat, Air Ride</p> <p>Seat Belt, Retractable, 3" wide</p> <p>Shift Control Unit for Automatic Shift</p> <p>Telescopic and Tilt Steering</p> <p>Torque Proportioning Differentials</p> <p>Transmission Declutch Adjust Switch            Selector Switch</p> <p>Vandalism Protection</p> <p>Wrist Rest, Adjustable</p>

OPTIONAL EQUIPMENT			
<p>Bellyguard, Hinged Transmission</p> <p>Bolt-On Cutting Edge Segments</p> <p>Bucket Teeth</p> <p>Cushion Dump Valve</p>	<p>ELS (Efficient Loading System)</p> <p>Emergency Steering</p> <p>Engine Pre-Cleaner, Turbine</p> <p>Fenders, Extra-Wide, Front &amp; Rear (hinged)</p> <p>F-R Direction Switch</p>	<p>HID Lighting (High Intensity Discharge)</p> <p>Hydraulic System, 3-Spool Valve</p> <p>K-Link</p> <p>Limited Slip Differentials</p> <p>Quick Coupler Attachments</p>	<p>Ride Control</p> <p>ROPS Canopy</p> <p>Single Lever Hydraulic Control</p> <p>Turn Signal With Four-Way Flasher</p>

# KAWASAKI KEEPS IT SIMPLE.



Since 1962, Kawasaki has been listening to and learning from customers and dealers in the field. As a result, Kawasaki wheel loaders continue to evolve, with a constant focus on one thing—producing the most durable, most efficient, most dependable machines possible.

## EASY TO OPERATE.

In a world of increasing demands, tighter deadlines, shrinking budgets and complicated contracts, better efficiency and greater productivity are a must. Innovative high-tech features on all Kawasaki wheel loaders allow the operator to adapt to the environment and the application right from the cab.

## EASY TO MAINTAIN.

Diagnostic and operational modules monitor fluids and filters, and constantly provide information on everything from engine and transmission codes to location, hours, alarm sensors and machine performance data.

## EASY TO DO BUSINESS WITH.

No run-arounds. No layers and layers of management. No distractions from competing product lines. Wheel loaders are our only business. Got a question? We'll get you an answer. Need a part? It's on its way. Quickly. Kawasaki offers flexible warranty programs, a state-of-the-art parts distribution system, an in-house rebuild center, and an experienced, knowledgeable support staff, focused on serving you.

The independent dealers that represent and support Kawasaki loaders are experts in their markets and are dedicated to providing you with the best service available.

Together, we are committed to making your investment in a Kawasaki loader a sound business decision that will pay dividends for years to come.

## KAWASAKI. ONE FOCUS. COMPLETE SOLUTIONS.



# Kawasaki

**Kawasaki Construction Machinery  
Corp. of America**

2140 Barrett Park Drive • Suite 101  
Kennesaw, Georgia 30144  
[www.kawasakiloaders.com](http://www.kawasakiloaders.com)

Tel: 770-499-7000  
Fax: 770-421-6842