



L-1850

SPECIFICATIONS

Engine	2000 hp (1491 kW)
Payload	
Standard	100,000 lbs (45,360 kgs)
High lift	94,000 lbs (42,639 kgs)
Bucket	sized to material density
Truck match	190-320 + tons



LeTourneau
TECHNOLOGIES™
| MINING
PRODUCTS

POWER MODULE

DIESEL POWER OPTIONS

DETROIT DIESEL ENGINE

	Tier One	Tier Two
Model	16V Series 4000 16 cylinders	16V Series 4000 16 cylinders
Type	4-cycle turbocharged	4-cycle turbocharged
Rated Power	2000 HP (1491 kW) @ 1900 rpm	2000 HP (1491 kW) @ 1800 rpm
Bore and Stroke	6.5 in x 7.5 in (165 mm x 190 mm)	6.69 in x 8.27 in (170 mm x 210 mm)
Displacement	3967 cu in (65 l)	4654 cu in (76.27 l)

CUMMINS DIESEL ENGINE

	Tier One	Tier Two
Model	QSK 60 16 cylinders	QSK 60 16 cylinders
Type	4-cycle turbocharged	4-cycle turbocharged
Rated Power	2000 HP (1491 kW) @ 1900 rpm	2000 HP (1491 kW) @ 1800 rpm
Bore and Stroke	6.26 in x 7.48 in (159 mm x 190 mm)	6.26 in x 7.48 in (159 mm x 190 mm)
Displacement	2746 cu in (45 l)	2746 cu in (45 l)

RADIATOR/OIL COOLER MODULE

- Split flow, side by side
- Thermostatically controlled,
- Independent hydraulic, motor-driven, radiator-mounted fan
- Variable-speed fan
- Auxiliary oil cooler available for high ambient conditions

AIR FILTRATION

- **LeTourneau Self-Cleaning KLENZ™ System**
99.9% Efficiency removing +0.3 microns
 - Longest filter maintenance interval in industry
- Supply filtered air for:
- Engine air
 - Drive system cooling
 - Pressurized cab

EXHAUST SYSTEM

Dual low restriction mufflers with vertical, mid-hood discharge

CONTROL SYSTEM – LINCS™

LeTourneau Integrated Network Control System- LINCS™

Microprocessor Based Full Digital Control and Monitoring

Hydraulics • Electrics • Engine • Propulsion System

- Modular design
- Built-in diagnostics
- Dash display and keypad

LINCS LOAD WEIGH

Integrated microprocessor based data logging and storage system displays real time load per pass, per truck and total loads

- Alerts operator if overload occurs
- Stores several months of production information
- Interfaces with radio dispatch systems for real-time monitoring

PROPULSION SYSTEM

- Solid-state AC-DC Phase Controlled Traction Drive
No Contactors or Power Switch Gear
Infinitely Variable Speed Control

TRAVEL SPEED

INFINITELY VARIABLE

Forward and reverse 0-10.5 mph (0-16.9 kph)

GENERATOR

- LeTourneau 12B generator
- Alternating-current, 3-phase, 4-pole
- Solid-state controlled
- Standby power capability

TRACTION MOTORS

- LeTourneau J2 traction motor (4)
- Direct-current, 4-pole, shunt-wound

DRIVE GEARING

Model **LeTourneau 57**

- In-line gear train mounted within the rim of the tire, transmitting power from the traction motor to the tire/rim assembly
- Each drive unit consists of a three-stage planetary
- Total reduction 99:1

PRIMARY BRAKING SYSTEM

Electric braking (retarding) is designed as the primary braking system which can be controlled from the accelerator or brake pedals. This solid-state, non-wearing braking system brings the loader to a full stop without application of the air-operated disc brakes.

SECONDARY AND PARKING BRAKE SYSTEM

Armature speed disc brakes, air-applied, spring-release, automatic actuation on all four wheels in the event of pressure loss.

Parking brakes are spring-applied, air-release.

FRAME

The unique LeTourneau frames are fabricated from high-strength, low-alloy steel with excellent weld characteristics and low temperature properties. The front axle is an integral, fixed part of the frame. The rear axle is allowed to oscillate a total of +/- 11 degrees.

The independent power module mounting system is cradled within the rear frame by a three-point isolation system.

STEERING AND HOISTING SYSTEM

STEERING

Articulating frame, joystick controlled power steering. The LeTourneau's constant-rated engine RPM provides full steering response regardless of vehicle speed.

• Operating pressure	3400 PSI (23,443 kPa)
• Articulation angle	42°
• Rear axle oscillation	+/- 11°
• Turning radius	
Standard lift	43 ft (13.11 m)
High lift	44 ft 1 in (13.44 m)

HOIST & BUCKET CONTROL

Hoist and bucket control functions are incorporated into a simple joystick control. The proportional electro-hydraulic controlled hoist and bucket system is independent of the steering system utilizing single stage, double-acting cylinders.

Standard/High Lift Cycle Times:

Hoist	14 Seconds
Dump	4 Seconds
Float	6 Seconds
Total Time	24 Seconds

HYDRAULIC SYSTEM

HPD DRIVE BOX

- Wet spline design with pressurized, cooled, and filtered lubrication
- Ratio 1:1

PUMPS

Main	Piston (4)	500 GPM	(1893 l/min)
Steering	Piston	90 GPM	(341 l/min)
Fan Drive	Piston	45 GPM	(170 l/min)
Blower	Vane	45 GPM	(170 l/min)
Accessory	Piston	14 GPM	(53 l/min)
Cooling System Circulating Pump	Vane	110 GPM	(416 l/min)

VALVES

Main	Three (3) Relief Pressure	175 GPM	(663 l/min) 3300 PSI (22,754 kPa)
Steering	One (1) Relief Pressure	80 GPM	(303 l/min) 3400 PSI (23,443 kPa)

CYLINDERS

Double-acting, single-stage (diameter and stroke), (standard and high lift)

- Hoist 15 in x 83 in (381 mm x 2108 mm)
- Bucket 12.5 in x 42.8 in (318 mm x 1086 mm)
- Steering 7.5 in x 30 in (190 mm x 762 mm)

GENERAL SERVICE DATA

FLUID TANK CAPACITIES

• Fuel	1050 gals	(3,975 l)
• Hydraulic	375 gals	(1,419 l)
• Cooling System	110 gals	(416 l)
• Crankcase (Includes Filters)		
Cummins	54 gals	(204 l)
Detroit Diesel	66 gals	(250 l)
• Gearbox	7 gals	(27 l)
• Drivers (each)	25 gals	(95 l)

STANDARD FEATURES

TIRES/RIMS

- Tires- 58/85-57 84 PR (L-4)
- Rims- 47 x 57 w/ 6" flange

GAUGES AND INDICATORS

- Engine coolant temperature gauge
- Engine lube-oil pressure gauge
- Fuel level gauge
- Hour meter
- Speedometer
- System air pressure gauge

INDICATOR LIGHTS AND AUDIBLE ALARMS

The operator is informed of a potential problem by an audible alarm and text message display. The digital display also provides repair technicians with operational data and fault messages in the event of a malfunction.

Three warning lights (red, amber or blue), immediately advise the operator of the severity/condition of various engine, hydraulic, electrical and electronic systems.

STANDARD EQUIPMENT

- Access Ladder Light Kit
- Air Clean Out Hose in Cab
- Air Conditioning/Heater-Defroster Filtered and Pressurized
- Air Dryer System
- Air Horn
- Air Tank Bleed Kit
- Automatic Adjustable Lift Height Cut Off
- Automatic Bucket Leveling Device
- Automatic Cabinet Lights
- Automatic Lubrication System
- Backup Alarm, Audible
- Battery Disconnect Switch
- Cigar/Cigarette Lighter

- Door Interlock on Electrical Cabinet
- Drawbar with Tow Hitch
- Emergency Exit - Removable Safety Window
- Emergency Stop - Cab and Remote Mounted
- Engine Compartment Lights
- Five (5) Gallon Windshield Washer Reservoir
- FOPS, Falling Object Protection System
- Ground Fault Electrics
- HID Headlights
- High, Low Idle Switch
- Idle Timer
- Illuminated Instrument Panel
- Interior Lights
- Joy Stick Hoist and Bucket Controls
- Joy Stick Steering
- Ladder Walkway-Rear Access with Retracting Ladder
- LINC'S Alarms
- LINC'S - LeTourneau Integrated Network Control System
- Manual Fire Extinguisher, 21 lbs (9.53 kgs)
- Maintenance Lock-Out Switch
- Mirror, Rearview (Parabolic) (2)
- Operator Seat - 9-Way Adjustable w/ Retractable Seat Belt
- Parking Brake
- Rock Deflectors (Bucket)
- ROPS, Rollover Protective Structure
- Standby Power Capability
- Sun Visor
- Tinted Safety Glass Throughout (Thermopane)
- Turn Signals
- Twelve (12) Volt Power Supply (Cab)
- Windshield Wipers, Front & Rear
- Work Lights, 110 Volt - 500 Watt (4) Front, (2) Rear

OPTIONAL FEATURES

- Auxiliary Cab Heater
- Auxiliary Oil Cooler
- Auxiliary Steering System
- Central Service with Fast Fuel
- Engine Heating System, Oil and Water
- Fast Fuel
- Fluid Sampling Kit
- Grease Reservoir Heater
- Hydraulic Tank and Battery Heater
- Jump Start Kit
- Manual Fire Detection and Suppression System
- Remote Monitoring System
- Standby Power
- Teeth and Lip Options Available
- Tires/Rims
 Tires- 58/85-57 84 PR (L-4) and 60/80R-57
 Rims- 47x57 w/5" flange
- Video Camera, Rear Mounted

BUCKETS

STANDARD, SAE-RATED CAPACITY: 100,000 LBS (45,360 KGS)

ROCK / COAL

Bucket sized to material density

HIGH LIFT, SAE-RATED CAPACITY: 94,000 LBS (42,639 KGS)

ROCK / COAL

Bucket sized to material density

BUCKET HARDWARE OPTIONS

- Skid plates - replaceable
- Lip wear protection
- Wear liner kits

For actual bucket configuration and sizing, consult your dealer representative.

OPERATING CAPACITIES, WEIGHTS, AND DIMENSIONS

	<u>STANDARD</u>		<u>HIGH LIFT</u>	
Bucket Capacity	33 yd ³	25.23 m ³	31 yd ³	23.70 m ³
Operating Payload	100,000 lbs	45,360 kgs	94,000 lbs	42,638 kgs
Bucket Width	21 ft 0 in	6.40 m	21 ft 0 in	6.40 m
Bucket Width with Deflectors	22 ft 0 in	6.71 m	22 ft 0 in	6.71 m
Hinge-Pin Height	30 ft 4 in	9.25 m	32 ft 2 in	9.80 m
Dump Clearance	22 ft 4 in	6.81 m	24 ft 2 in	7.35 m
Reach @ Full Lift	9 ft 8 in	2.94 m	9 ft 8 in	2.92 m
Digging Depth	0 ft 6 in	0.15 m	0 ft 8 in	0.24 m
Height - Bucket Fully Raised	39 ft 9 in	12.12 m	41 ft 2 in	12.54 m
Ground Clearance	2 ft 6 in	0.76 m	2 ft 6 in	0.76 m
Overall Length Bucket Down	58 ft 6 in	17.83 m	60 ft 0 in	18.29 m
Overall Length Carry Position	56 ft 10 in	17.32 m	58 ft 2 in	17.73 m
Wheelbase	23 ft 0 in	7.01 m	23 ft 0 in	7.01 m
Tread	15 ft 0 in	4.57 m	15 ft 0 in	4.57 m
Width Outside Tires	19 ft 10 in	6.04 m	19 ft 10 in	6.04 m
Height Over Cab	20 ft 11 in	6.68 m	20 ft 11 in	6.68 m
Static Tipping Loads:				
Straight	225,000 lbs	102,060 kgs	215,000 lbs	97,524 kgs
Full 42° Turn	200,000 lbs	90,720 kgs	190,000 lbs	86,184 kgs
Breakout Force	276,181 lbs	125,274 kgs	280,672 lbs	127,311 kgs
Operating Weight	506,000 lbs	229,520 kgs	511,000 lbs	231,788 kgs

STANDARD CONFIGURATION

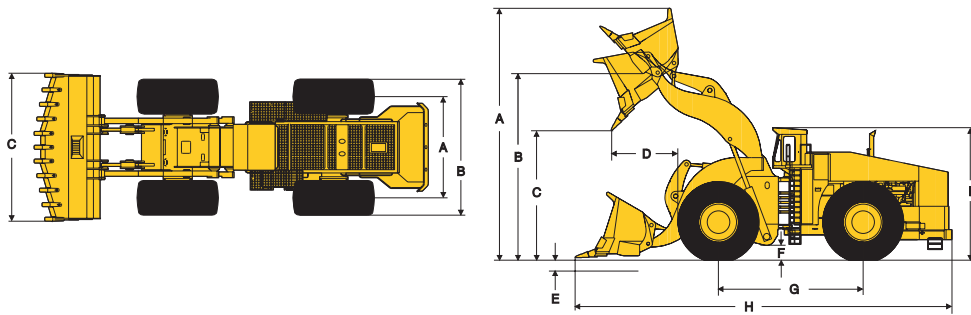

TOP VIEW

(A)	15 ft 0 in	4.57 m
(B)	19 ft 10 in	6.04 m
(C)	21 ft 0 in	6.40 m

SIDE VIEW

Bucket	33 yd ³	25.23 m ³
(A)	39 ft 9 in	12.12 m
(B)	30 ft 4 in	9.25 m
(C)	22 ft 4 in	6.81 m
(D)	9 ft 8 in	2.94 m
(E)	0 ft 6 in	0.15 m
(F)	2 ft 6 in	0.79 m
(G)	23 ft 0 in	7.01 m
(H)	58 ft 6 in	17.83 m
(I)	20 ft 11 in	6.68 m

STANDARD LIFT

HIGH LIFT

Bucket	31 yd ³	23.70 m ³
(A)	41 ft 2 in	12.54 m
(B)	32 ft 2 in	9.8 m
(C)	24 ft 2 in	7.35 m
(D)	9 ft 8 in	2.92 m
(E)	0 ft 8 in	0.24 m
(F)	2 ft 6 in	0.79 m
(G)	23 ft 0 in	7.01 m
(H)	60 ft 0 in	18.29 m
(I)	20 ft 11 in	6.68 m

All dimensions calculated with teeth on bucket.



P.O. Box 2307 • Longview, TX 75606 • (903) 236-6598 • fax (903) 236-6552 • www.letourneautechnologies.com

Meets the following MSHA, SAE and ISO Safety Standards:

Brake Performance Test SAE J1473 / ISO 3450 • Capacity Rating - Loader Bucket SAE J742 • Exterior Sound Level SAE J88 • FOPS SAE J231 / ISO 3449
Interior Sound Level SAE J919 • Rated Operating Load for Loaders SAE J818 • ROPS SAE J1040 / ISO 3471 • Steering Test SAE J1511 / ISO 5010

Please Note: Standard/Optional Equipment, Features and Performance conform to U.S. and International Codes as Required. LeTourneau Technologies, Inc. has made every effort to make these specifications as accurate as possible at the time of printing. However, we reserve the right to make changes and improvements at any time without notice, in equipment, materials and specifications. To ensure the most current information, please contact your dealer representative.

LeTourneau Equipment Group is now known as LeTourneau Technologies™ Mining Products. LeTourneau, KLENZ, and LINCS are registered trademarks of LeTourneau Technologies, Inc. ©2007