

Attachment Information

Liebherr Crawler Excavator
with Multi-User Attachment

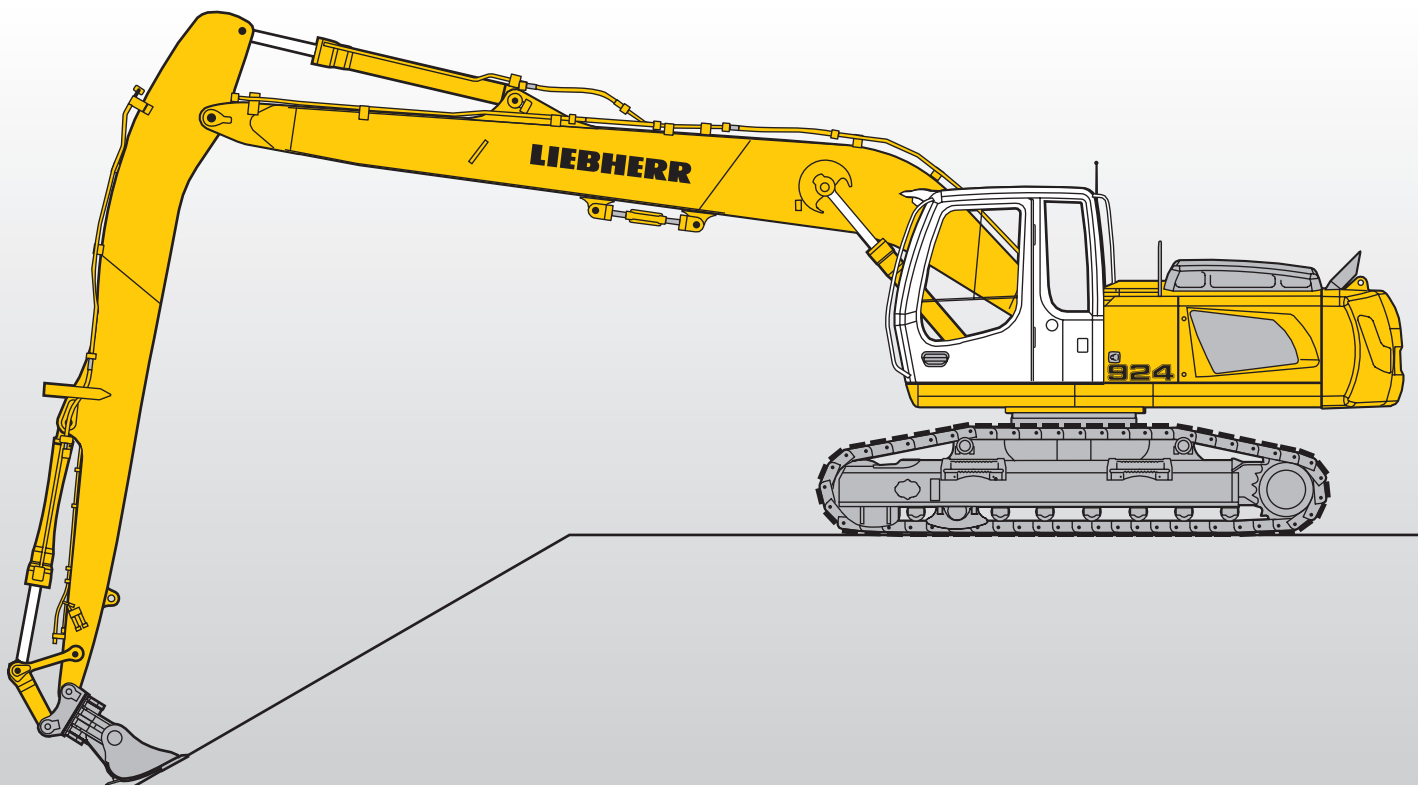

Ditchcleaning Attachment «Multi-User»

with Gooseneck Boom 9,00 m for Ditchcleaning Attachment and HD-SL-Undercarriage

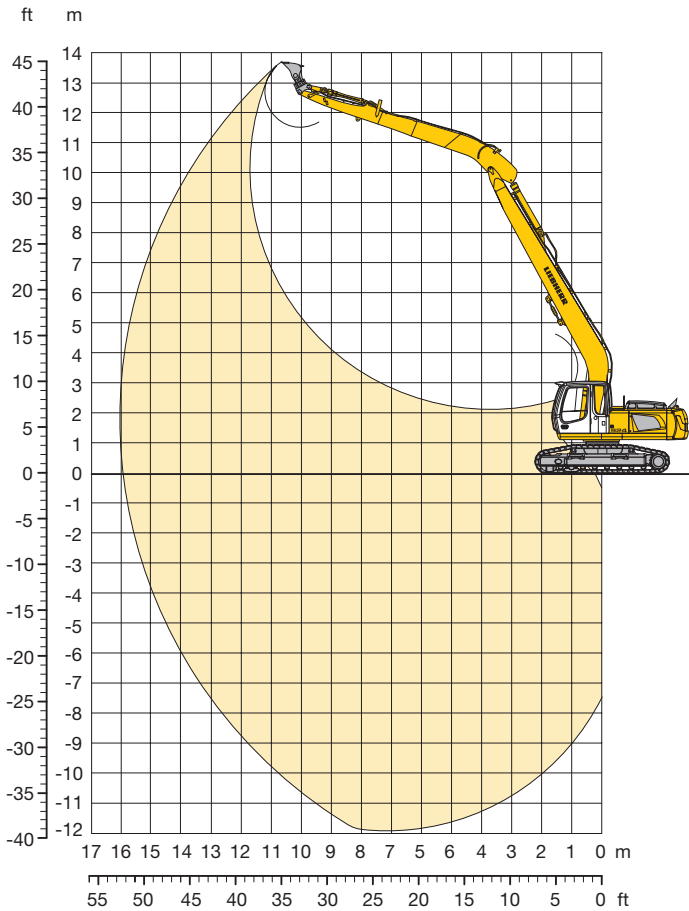

Digging Envelope for Ditchcleaning Bucket

Stick length	m	6,80
Max. digging depth	m	11,85
Max. reach at ground level	m	15,90
Max. dump height	m	11,50
Max. teeth height	m	13,70
Digging force ISO	kN	62,0
	t	6,3
Breakout force ISO	kN	117,0
	t	11,9

Operating Weight and Ground Pressure

Operating weight includes basic machine, gooseneck boom 9,00 m for ditchcleaning attachment, stick 6,80 m for ditchcleaning attachment and ditchcleaning bucket 0,40 m³ (370 kg).

Undercarriage		HD-SL		
Pad width	mm	500	600	750
Weight	kg	26775	27055	27480
Ground pressure	kg/cm ²	0,65	0,55	0,45

Ditchcleaning Bucket Type 904

Cutting width SAE	mm	2000	2000 ¹⁾
Capacity ISO 7451	m ³	0,40	0,50
Weight	kg	370	680
Specific weight	t/m ³	1,80	1,50

¹⁾ Ditchcleaning bucket 2 x 50° tiltable

Bucket Type 904

Cutting width SAE	mm	850	1050	1250
Capacity ISO 7451	m ³	0,55	0,70	0,90
Weight	kg	530	595	685
Specific weight	t/m ³	1,80	1,50	1,20

Lift Capacities

with Gooseneck Boom 9,00 m for Ditchcleaning Attachment and HD-SL-Undercarriage

Stick for Ditchcleaning Attachment 6,80 m

Height (m)	Under-carriage	Radius of load from centerline of machine (m)								
		4,5	6,0	7,5	9,0	10,5	12,0	13,5	15,0	
10,5	HD-SL							0,8# (0,8#)		
9,0	HD-SL							1,4# (1,4#)		
7,5	HD-SL						2,1# (2,1#)	1,7# (1,7#)	0,9# (0,9#)	
6,0	HD-SL						2,5# (2,5#)	1,8 (2,1#)	1,3 (1,4#)	
4,5	HD-SL						3,0# (3,0#)	2,3 (2,7#)	1,7 (2,4#)	1,2 (1,7#)
3,0	HD-SL		5,1# (5,1#)	4,0 (4,0#)	2,9 (3,4#)	2,1 (2,9#)	1,6 (2,6#)	1,1 (2,1#)		
1,5	HD-SL	7,5 (8,5#)	4,9 (5,9#)	3,5 (4,6#)	2,6 (3,7#)	1,9 (3,1#)	1,4 (2,7)	1,0 (2,2)	0,7 (0,8#)	
0	HD-SL	6,3 (7,6#)	4,2 (6,6#)	3,1 (5,0#)	2,3 (4,0#)	1,7 (3,3)	1,3 (2,6)	0,9 (2,1)		
- 1,5	HD-SL	5,7 (6,4#)	3,8 (6,9#)	2,7 (5,2)	2,0 (4,0)	1,5 (3,1)	1,1 (2,5)	0,9 (2,0)		
- 3,0	HD-SL	5,4 (6,6#)	3,5 (7,0#)	2,5 (5,0)	1,9 (3,8)	1,4 (3,0)	1,1 (2,4)	0,8 (1,9)		
- 4,5	HD-SL	5,4 (7,3#)	3,4 (6,8#)	2,4 (4,9)	1,8 (3,7)	1,3 (2,9)	1,0 (2,3)			
- 6,0	HD-SL	5,4 (8,2#)	3,4 (6,4#)	2,3 (4,8)	1,7 (3,6)	1,3 (2,8)	1,0 (2,3)			
- 7,5	HD-SL	5,6 (7,4#)	3,5 (5,7#)	2,4 (4,5#)	1,8 (3,6#)	1,3 (2,9)				
- 9,0	HD-SL	6,0 (6,0#)	3,7 (4,7#)	2,5 (3,7#)	1,9 (3,0#)					
- 10,5	HD-SL	4,0# (4,0#)	3,2# (3,2#)	2,5# (2,5#)						

The lift capacities are stated in metric tonnes (t) on the articulation stick/bucket (bucket's weight included) and can be lifted 360° on firm, level supporting surface. Values quoted in brackets are valid for the undercarriage when in longitudinal position. Capacities are valid for 600 mm wide triple grouser pads. Indicated loads are based on ISO 10567 standard and do not exceed 75 % of tipping or 87 % of hydraulic capacity (indicated via #). Without bucket (0,55 m³), the lift capacities will increase by 530 kg, without bucket cylinder, link and lever they increase by an additional 275 kg. Lifting capacity of the excavator is limited by machine stability, hydraulic capacity and maximum permissible load of the load hook. According to European Standard, EN 474-5: In the European Union excavators have to be equipped with an overload warning device, a load diagram and automatic check valves on the hoist cylinders, when they are used for lifting operations which require the use of lifting accessories.

Ditchcleaning Attachment «Multi-User»

with Gooseneck Boom 8,20 m for Ditchcleaning Attachment and HD-SL-Undercarriage

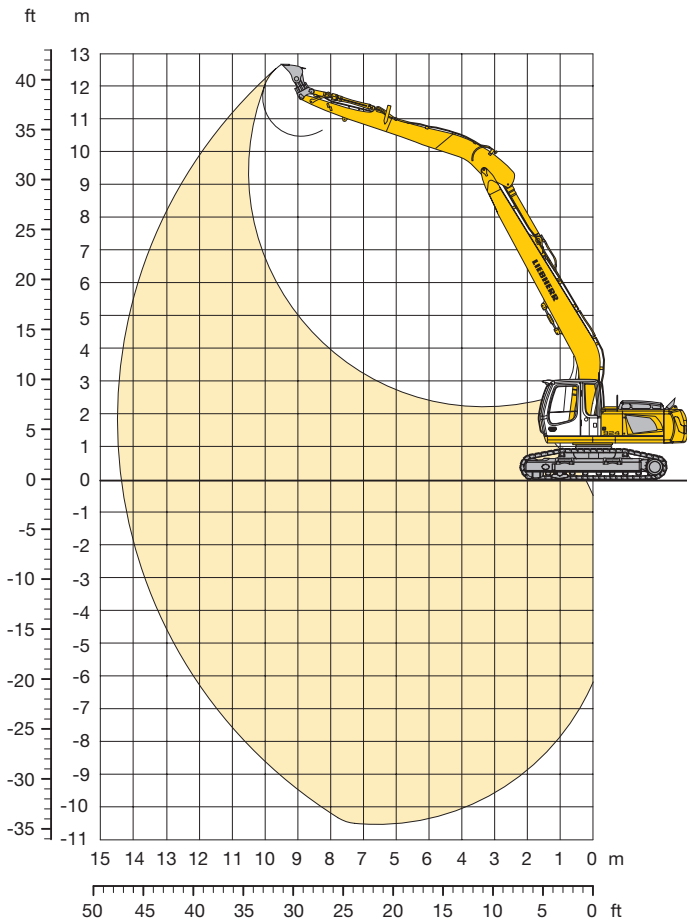

Digging Envelope for Ditchcleaning Bucket

Stick length	m	6,00
Max. digging depth	m	10,45
Max. reach at ground level	m	14,35
Max. dump height	m	10,50
Max. teeth height	m	12,65
Digging force ISO	kN	69,0
	t	7,0
Breakout force ISO	kN	117,0
	t	11,9

Operating Weight and Ground Pressure

Operating weight includes basic machine, gooseneck boom 8,20 m for ditchcleaning attachment, stick 6,00 m for ditchcleaning attachment and ditchcleaning bucket 0,70 m³ (500 kg).

Undercarriage		HD-SL		
Pad width	mm	500	600	750
Weight	kg	26595	26875	27300
Ground pressure	kg/cm ²	0,65	0,54	0,44

Ditchcleaning Bucket Type 904

Cutting width SAE	mm	2000	2000 ¹⁾
Capacity ISO 7451	m ³	0,70	0,70
Weight	kg	500	800
Specific weight	t/m ³	1,80	1,50

¹⁾ Ditchcleaning bucket 2 x 50° tiltable

Bucket Type 904

Cutting width SAE	mm	1050	1250	1400
Capacity ISO 7451	m ³	0,70	0,90	1,05
Weight	kg	595	685	730
Specific weight	t/m ³	1,80	1,50	1,20

Lift Capacities

with Gooseneck Boom 8,20 m for Ditchcleaning Attachment and HD-SL-Undercarriage

Stick for Ditchcleaning Attachment 6,00 m

Height (m)	Under-carriage	Radius of load from centerline of machine (m)								
		4,5	6,0	7,5	9,0	10,5	12,0	13,5	15,0	
10,5	HD-SL									
9,0	HD-SL						1,6# (1,6#)			
7,5	HD-SL						2,1# (2,1#)			
6,0	HD-SL					3,0# (3,0#)	2,5 (2,5#)	1,7# (1,7#)		
4,5	HD-SL				3,9# (3,9#)	3,2 (3,5#)	2,4 (3,1#)	1,8 (2,2#)		
3,0	HD-SL	7,4# (7,4#)	5,6# (5,6#)	4,1 (4,5#)	3,0 (3,8#)	2,2 (3,4#)	1,6 (2,6#)			
1,5	HD-SL	7,9 (9,2#)	5,2 (6,5#)	3,7 (5,1#)	2,7 (4,2#)	2,0 (3,6#)	1,5 (2,8)			
0	HD-SL	6,9 (10,0#)	4,6 (7,2#)	3,3 (5,5#)	2,5 (4,4)	1,9 (3,4)	1,4 (2,7)			
- 1,5	HD-SL	6,4 (8,5#)	4,2 (7,5#)	3,0 (5,6)	2,3 (4,2)	1,7 (3,3)	1,3 (2,6)			
- 3,0	HD-SL	6,2 (8,7#)	4,0 (7,5#)	2,9 (5,4)	2,1 (4,1)	1,7 (3,2)	1,3 (2,6)			
- 4,5	HD-SL	6,2 (9,7#)	3,9 (7,2#)	2,8 (5,3)	2,1 (4,0)	1,6 (3,2)				
- 6,0	HD-SL	6,3 (8,7#)	4,0 (6,6#)	2,8 (5,2#)	2,1 (4,0)	1,6 (3,2)				
- 7,5	HD-SL	6,5 (7,2#)	4,1 (5,6#)	2,9 (4,4#)	2,2 (3,4#)					
- 9,0	HD-SL	5,1# (5,1#)	4,0# (4,0#)	3,1# (3,1#)						
- 10,5	HD-SL									

The lift capacities are stated in metric tonnes (t) on the articulation stick/bucket (bucket's weight included) and can be lifted 360° on firm, level supporting surface. Values quoted in brackets are valid for the undercarriage when in longitudinal position. Capacities are valid for 600 mm wide triple grouser pads. Indicated loads are based on ISO 10567 standard and do not exceed 75 % of tipping or 87 % of hydraulic capacity (indicated via #). Without bucket (0,55 m³), the lift capacities will increase by 530 kg, without bucket cylinder, link and lever they increase by an additional 275 kg. Lifting capacity of the excavator is limited by machine stability, hydraulic capacity and maximum permissible load of the load hook. According to European Standard, EN 474-5: In the European Union excavators have to be equipped with an overload warning device, a load diagram and automatic check valves on the hoist cylinders, when they are used for lifting operations which require the use of lifting accessories.

Dimensions

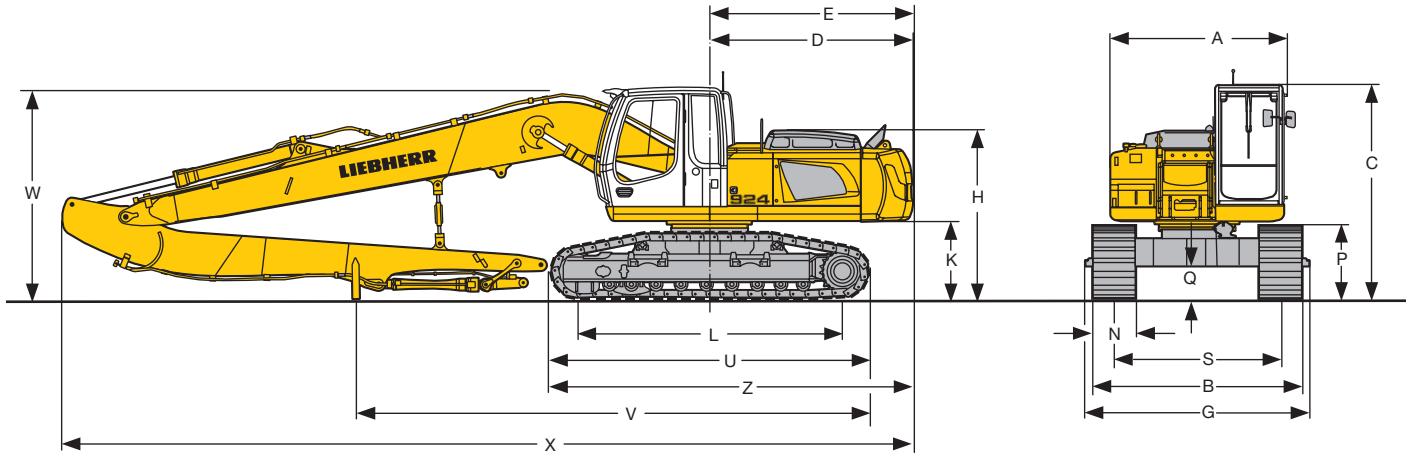

	mm		
A	2500		
C	3070		
D	2920		
E	2940		
H	2425		
K	1100		
L	3830		
P	995		
Q	470		
S	2400		
U	4635		
N	500	600	750
B	2966	3000	3150
G	3160	3160	3160
Z	5250		

Gooseneck Boom 8,20 m for Ditchcleaning Attachment, Stick 6,00 m for Ditchcleaning Attachment and HD-SL-Undercarriage

V	7400
W	3000
X	12250

Gooseneck Boom 9,00 m for Ditchcleaning Attachment, Stick 6,80 m for Ditchcleaning Attachment and HD-SL-Undercarriage

V	7400
W	3050
X	13050

Liebherr-France SAS

2, avenue Joseph Rey, B.P. 90287, F-68005 Colmar Cedex

+33 389 21 30 30, Fax +33 389 21 37 93

www.liebherr.com, E-Mail: info.lfr@liebherr.com