

Wheel Loaders

L 524 - L 542
2plus1 2plus1

Tipping load, articulated: 7,300 kg – 9,760 kg



LIEBHERR

L 524 2plus1

Tipping load, articulated: 7,300 kg
Bucket capacity: 2.0 m³
Operating weight: 10,600 kg
Engine output: 86 kW

L 528 2plus1

Tipping load, articulated: 8,100 kg
Bucket capacity: 2.2 m³
Operating weight: 11,100 kg
Engine output: 86 kW

L 538 2plus1

Tipping load, articulated: 9,020 kg
Bucket capacity: 2.5 m³
Operating weight: 12,755 kg
Engine output: 105 kW

L 542 2plus1

Tipping load, articulated: 9,760 kg
Bucket capacity: 2.7 m³
Operating weight: 13,320 kg
Engine output: 105 kW



Economy

The Liebherr driveline combined with low operating weight and high tipping load results in up to 25 % less fuel consumption compared with conventionally driven wheel loaders. Up to 5 litres of fuel per operating hour can be saved, which means lower operating costs and an active protection of the environment at the same time.

Performance

The Liebherr driveline enables the Liebherr diesel engine to be installed in the ideal position. For this class of wheel loader, it is transversely mounted at the rear. This greatly increases the tipping load and the handling capacity per operating hour at a lower operating weight than conventional wheel loaders.

Reliability

All the materials used have passed long-time tests to ensure that they comply with Liebherr's high quality standards in even the toughest conditions. A sophisticated concept and proven quality mean that Liebherr wheel loaders set the standard when it comes to reliability.

Comfort

The ultra-modern cabin design with advanced ergonomics, continuously variable Liebherr driveline without interruption of tractive force thanks to the "2plus1" gearbox, optimal weight distribution and a transversely-mounted engine for excellent maintenance access lead to unequalled overall comfort.





Lower fuel consumption

- A fuel saving of up to 5 litres per operating hour represents a cost saving of up to 25 %.
- The Liebherr standard test demonstrates the operating efficiency of Liebherr wheel loaders.



Economy

The Liebherr driveline combined with low operating weight and high tipping load results in up to 25 % less fuel consumption compared with conventionally driven wheel loaders. Up to 5 litres of fuel per operating hour can be saved, which means lower operating costs and an active protection of the environment at the same time.

Low operating costs

Minimum costs, high handling capacity

When it comes to economy, conventional wheel loaders are no match for Liebherr machines, mainly due to the following factors:

- Low fuel consumption as a result of higher efficiency and a lower operating weight. The Liebherr wheel loader's fuel consumption is up to 5 litres per operating hour lower than a conventional wheel loader under the same working conditions.
- Virtually no brake wear, thanks to the hydraulic braking action of the driveline. This means no brake repair costs resulting from wear and tear.
- Continuous traction control for reduced tyre wear. Depending on the working conditions, tyre wear can be up to 25 % lower than with conventional wheel loaders.

Active environmental protection

Economical use of resources

Reduced fuel consumption means lower emissions, which leads to the active and economical use of resources.

During combustion, 1 litre of diesel produces up to 3 kg of CO₂. A saving of 5 litres of fuel per operating hour translates into a 15,000-kilogram reduction in CO₂ emissions over a period of 1,000 operating hours, for example. The result: reduced fuel costs and active protection of the environment.

Low noise emissions

The innovative driveline concept also cuts noise emissions considerably: Liebherr wheel loaders are significantly quieter in operation.



Reduced brake wear

- Even in the toughest working conditions, the Liebherr travel drive is always braked hydraulically. The mechanical service brake is used only as a secondary braking function – as such – the brakes are virtually wear-free.



Reduced tyre wear

- The tractive force can be adjusted continuously. This prevents wheelspin and reduces tyre wear by up to 25 %.



Liebherr driveline

- Optimum weight distribution thanks to transverse installation of the Liebherr diesel engine.
- The Liebherr diesel engine is used as a counterweight - so high tipping load at low operating weight.
- Compact design improves visibility in all directions.

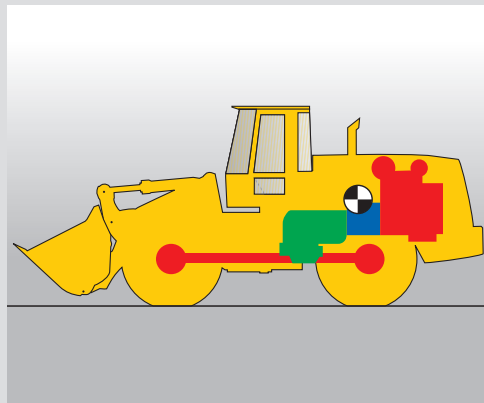
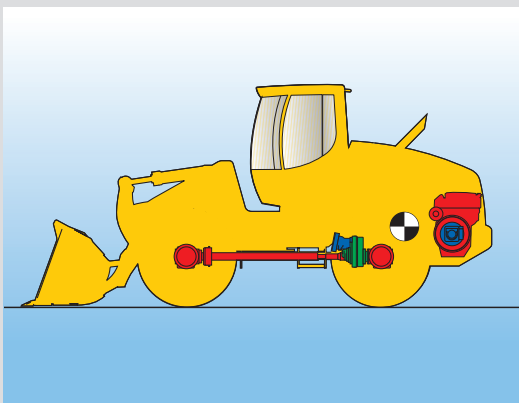

Performance

The Liebherr driveline enables the Liebherr diesel engine to be installed in the ideal position. For this class of wheel loader, it is transversely mounted at the rear. This greatly increases the tipping load and the handling capacity per operating hour at a lower operating weight than conventional wheel loaders.

Higher performance, lower weight

Higher productivity, lower operating weight

Liebherr's driveline enables the Liebherr diesel engine to be installed transversely at the rear of the wheel loader. This increases the tipping load while keeping the operating weight low. Productivity is greatly increased because no unnecessary counterweight has to be carried on the machine.

Ultra-modern Liebherr driveline

Innovative technology

Liebherr Allround wheel loaders are equipped with a "2plus1" gearbox. Tractive force and speed are adapted to suit demand – automatically and without gear changes. Even the change from forward to reverse travel is controlled hydraulically, so that no mechanical reverse gear is required.

Flexibility puts them ahead

An all-purpose loader

The Allround wheel loader models can be supplied with either a parallel or a Z-pattern linkage. This gives them the ideal equipment for tackling a variety of tasks. Their compact design allows these wheel loaders to manoeuvre quickly and efficiently – an ideal basis for high handling capacity.



Conventional travel gear

- Longitudinally mounted diesel engine moves the centre of gravity to the further forward.
- Much more additional counterweight is needed to maintain stability and to increase the tipping load.
- This leads to high operating weight and bad visibility.



An all-purpose loader

- The choice between parallel (P) and Z-pattern linkage means that the loader can always be configured to suit the customer's specific tasks: P for industrial use, Z for conventional material handling.

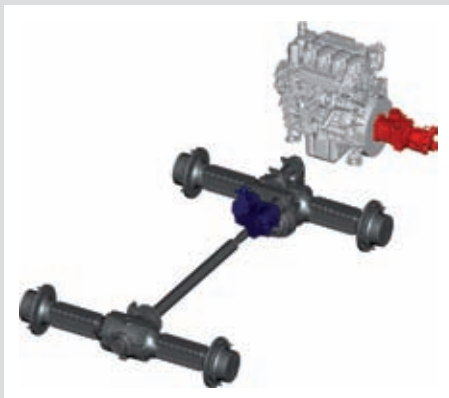

Liebherr driveline

- The Liebherr driveline consists of two hydraulic motors, which accelerate the loader continuously from a standstill to maximum speed, either forwards or in reverse – without a manual gear shift and a reversing gear unit.



Reliability

All the materials used have passed long-time tests to ensure that they comply with Liebherr's high quality standards in even the toughest conditions. A sophisticated concept and proven quality mean that Liebherr wheel loaders set the standard when it comes to reliability.

Reliable Liebherr driveline

Fewer components

Liebherr's driveline includes a self-locking hydraulic brake, with the result that the additional wet brake discs are effectively wear-free. A reversing gear unit is not required, thereby reducing the number of components susceptible to wear.

Controlled cooling

The intelligent answer

The cooling fan is not driven directly from the Liebherr diesel engine, and produces only the cooling air output that is needed at any given moment. Heat sensors control its operating speed, and if overheating should occur, the wheel loader shifts down automatically to the lowest travel speed range.

Since less power is then consumed, the Liebherr diesel engine is better protected against overheating. At the same time, the fan speed is increased to the maximum value, for the best possible protection of all components.

Components to the manufacturer's quality standards

Everything from a single source

Important components such as the engine, hydraulic rams and electronics are manufactured by Liebherr itself – which means co-ordinated quality from the manufacturer down to the smallest detail to ensure the highest possible performance and reliability.



Cooling system

- The radiator is installed on the rear section of the vehicle, between the diesel engine and the cabin. Cooling air is drawn in directly behind the cabin and blown out upwards at the rear. The fan speed is varied automatically by heat sensors that determine the amount of cooling needed.
- A reversible fan drive to expel dust from the radiator can be specified as an optional extra.



Liebherr's own components

- Liebherr has many years of experience in the design, development and construction of diesel engines, hydraulic rams and electronic components. They are all matched together down to the smallest detail for use on its wheel loaders.



Liebherr control lever

- The Liebherr control lever is used to manage all the machine's travel and working movements. The operator's left hand can remain on the steering wheel at all times without having to reach for other control levers – a valuable safety feature. The operator controls the following functions with his right hand:

- Raise and lower attachment
- Fill and dump the bucket
- Automatic bucket repositioning
- Change of travel direction with simultaneous travel start
- Controls for additional hydraulic functions



Comfort

The ultra-modern cabin design with advanced ergonomics, continuously variable Liebherr driveline without no interruption of tractive force thanks to the “2plus1” gearbox, optimal weight distribution and a transversely-mounted engine for excellent maintenance access lead to unequalled overall comfort.

Top-class cabin design

Comfort cabin

This ultra-modern, ergonomically planned cabin design is the basis for increased performance and productivity of the operator. The displays, controls and driver's seat are carefully coordinated to form a perfect ergonomic unit.

Liebherr control lever

All working and travel functions are operated precisely and sensitively from a single control lever. This means accurate and safe handling, and the left hand always remains on the steering wheel. This increases the safety at the job site.

Liebherr driveline

Continuously variable transmission

Liebherr's driveline with a “2plus1” gearbox enables the wheel loader to accelerate smoothly and continuously in all speed ranges, with no discernable gear shifts and no interruptions to tractive force.

Unique oscillation system

The combination of centre pivot and rear swing axle reduces the cab tilt by 50 % and this again makes the working conditions much more pleasant for the operator.

Service accessibility

Straightforward maintenance

The transversely-installed Liebherr diesel engine allows excellent ease of access for maintenance. All maintenance points can be reached easily and safely from ground level when a single engine hood is opened.

Hydrostatic fan drive

The cooling system is located directly behind the cabin. This reduces the accumulation of dust and thus the need for cleaning and maintenance work, which in turn saves both time and money.



Service accessibility

- The transversely installed Liebherr diesel engine enables an easy accessibility for maintenance. Lifting a hinge up cover allows you a safe and convenient access to all maintenance points from ground level.



Unique oscillation system

- The combination of centre pivot and rear swing axle reduces the cab tilt by 50 %. This leads to greater operator comfort based on the reduction of the cab tilt.

- Initial position
- Liebherr wheel loader
- Conventional wheel loader
- Lateral slope angle

Technical Data



Engine

	L 524 2plus1	L 528 2plus1	L 538 2plus1	L 542 2plus1
Diesel engine	4045 HF 286I	4045 HF 286I	D 934 S AG	D 934 S AG
Design	4-cylinder, inline engine, water-cooled, turbo charged, intercooled			
Rated output according to ISO 9249	kW 86			
at RPM 2,400	86	105	105	105
Max. torque	Nm 430			
at RPM 1,500	430	770	770	770
Displacement	Liter 4.5			
Bore/Stroke	106/127	106/127	122/136	122/136
Air cleaner system	Dry air filter with main and safety element, pre-cleaner, service indicator on LCD display			
Electrical system				
Operating voltage	V 24			
Battery	Ah/V 2 x 135/12			
Alternator	Three-phase AC			
Starter	V/A 24/55			
	24	24	24	24
	2 x 135/12	2 x 135/12	2 x 135/12	2 x 135/12
	24/55	28/80	28/80	24/5.4
	24/7	24/7	24/5.4	24/5.4

The exhaust emissions are below the limits in stage IIIA/Tier 3.



Travel Drive

Steppless hydrostatic travel drive	Swash plate type variable flow pump and two variable axial piston motors in closed loop circuit and axle transfer case 2plus1. Direction of travel is reversed by changing the flow-direction of the variable-displacement pump			
Design "2plus1"				
Filtering system	Suction filter for closed circuit			
Control	By travel and inching pedal. The inching pedal makes it possible to control the tractive and thrust forces steplessly at full engine speed. The Liebherr joystick is used to control forward and reverse travel			
Travel speed range	Speed range 1 0 - 6.0 km/h			
	Speed range A1-2 0 - 16.0 km/h			
	Speed range A1-3 0 - 40.0 km/h			
	The quoted speeds apply with the tyres that are standard equipment on the loader			



Axles

Four-wheel drive	Fixed			
Front axle	Centre pivot, with 6° oscillating angle to each side. 470 mm in height can be driven over (with all four wheels remain in contact with the ground)			
Rear axle				
Differentials	Automatic limited-slip differentials with 45 % locking action in both axles			
Reduction gear	Planetary final drive in wheel hubs			
Track width	1,960 mm with all types of tyres (L 524, L 528)			
	1,900 mm with all types of tyres (L 538, L 542)			



Brakes

Wear-free service brake	Self-locking of the hydrostatic travel drive (acting on all four wheels) and additional pump-accumulator brake system with wet multi-disc brakes located in the differential housing (two separate brake circuits)			
Parking brake	Electro-hydraulically actuated spring-loaded disc brake system on the front axle			

The braking system meets the requirements of the EC guidelines 71/320.



Steering

Design	Hydraulic servo power steering Central oscillating frame articulation with damper element			
Articulation angle	40° (to each side)			
Oscillating angle	6° (to each side)			
Max. pressure	230 bar			
Emergency steering	Electro-hydraulic emergency steering system			



Attachment Hydraulics

Design	"Load-Sensing" variable axial piston pump with output and flow control, and pressure cut-off in the control block			
Cooling	Hydraulic oil cooling using thermostatically controlled fan and oil cooler			
Filtration	Return line filter in the hydraulic reservoir			
Control	"Liebherr joystick" with hydrostatic servo control			
Lift circuit	Lifting, neutral, lowering and float position controlled by Liebherr joystick with detent; automatic lifting-limit circuit optional			
Tilt circuit	Tilt back, neutral, dump automatic bucket positioning			
	L 524 2plus1	L 528 2plus1	L 538 2plus1	L 542 2plus1
Max. flow	105	105	140	140
Max. pressure	315	315	330	330



Attachment

Geometry can be chosen _____ Powerful Z-bar linkage with one tilt cylinder, hydr. quick change coupler - optional equipment
 _____ Parallel linkage with two tilt cylinders, hydr. quick change coupler - standard equipment

Bearings	Sealed							
Cycle time at nominal load	L 524 2plus1		L 528 2plus1		L 538 2plus1		L 542 2plus1	
	ZK	PK	ZK	PK	ZK	PK	ZK	PK
Lifting	6.6	6.6	6.6	6.6	5.9	5.9	5.9	5.9
Dumping	1.8	3.5	1.8	3.5	1.6	3.5	1.6	3.5
Lowering (empty)	4.0	4.0	4.0	4.0	4.0	4.0	4.0	4.0



Operator's Cab

Design	On elastic bearing on rear section, soundproof ROPS/FOPS cab. Operator's door with optional sliding window, 180° opening angle, fold-out window on right side with opening angle, front windscreen made of compound safety glass, green tinted as standard, side windows made of single-pane safety glass, grey tinted, continuously adjustable steering column and joystick control as standard, heatable rear window			
	ROPS roll over protection per DIN/ISO 3471/EN 474-3			
	FOPS falling objects protection per DIN/ISO 3449/EN 474-1			
Liebherr Operator's seat	6 way adjustable seat with lap belt, vibration damping and suspension adjustable for the operator's weight			
Cab heating and ventilation	Operator's cab with 4-level air control, cooling water heating, defroster and air conditioning with electronic valve control, as well as electronic fresh/recirculated air control, filter system with pre-filter, fresh air filter and recirculated air filter, easily replaced, air condition optional			



Noise Emission

	L 524 2plus1	L 528 2plus1	L 538 2plus1	L 542 2plus1
ISO 6396				
L _{DA} (inside cab)	69 dB(A)	69 dB(A)	69 dB(A)	69 dB(A)
2000/14/EC				
L _{WA} (surround noise)	101 dB(A)	101 dB(A)	102 dB(A)	102 dB(A)



Capacities

	L 524 2plus1	L 528 2plus1	L 538 2plus1	L 542 2plus1
Fuel tank	170	170	170	170
Engine oil				
(inclusive filter change)	12	12	29	29
Pump distributor gears	3.8	3.8	3.8	3.8
Front axle/wheel hubs	16.3/2.6	16.3/2.6	16.3/2.6	16.3/2.6
Rear axle/wheel hubs	15/2.6	15/2.6	15/2.6	15/2.6
Hydraulic tank	110	110	110	110
Hydraulic system, total	170	170	180	180

Z-bar Linkage

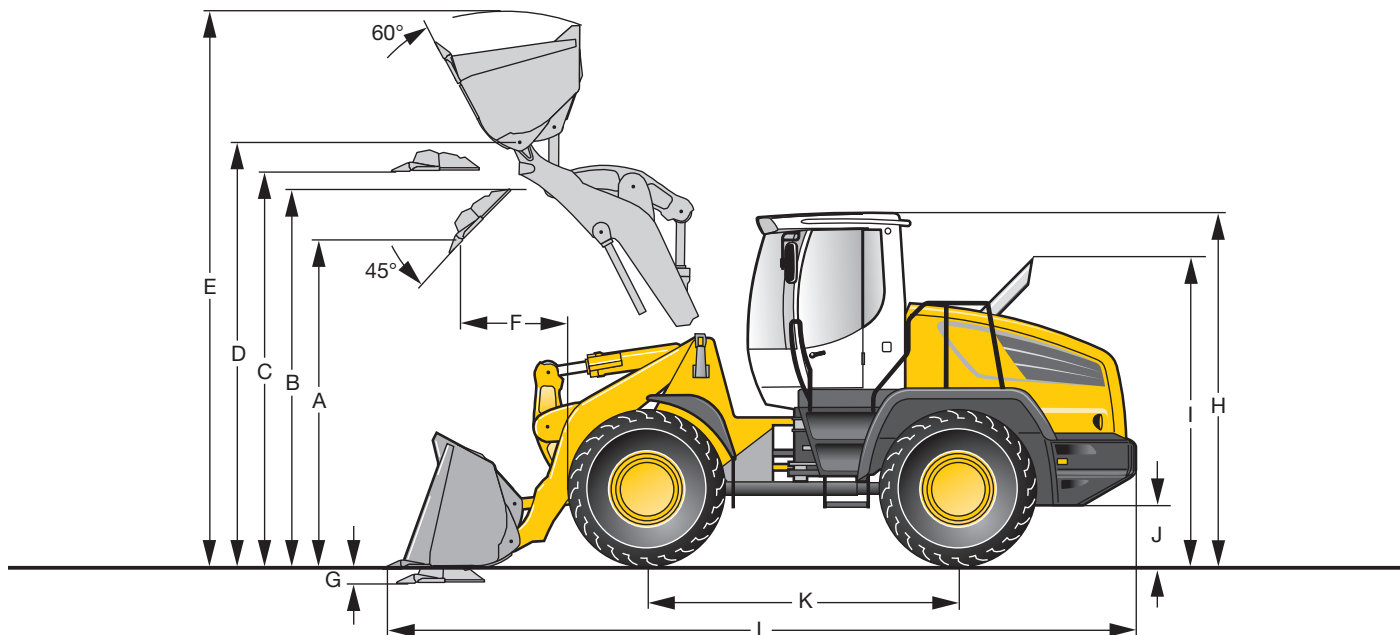

		L 524 ^{2plus1}			L 528 ^{2plus1}			L 538 ^{2plus1}			L 542 ^{2plus1}			
	Bucket type	GPB	QH	LMB	GPB	QH	LMB	GPB	QH	LMB	GPB	QH	LMB	
	Cutting tools	T	T	BOCE	T	T	BOCE	T	T	BOCE	T	T	BOCE	
	Bucket capacity according to ISO 7546**	m ³	2.0	1.7	2.4	2.2	2.0	3.0	2.5	2.2	3.5	2.7	2.4	4.0
	Bucket width	mm	2,500	2,500	2,500	2,500	2,500	2,750	2,500	2,500	2,750	2,500	2,500	2,750
	Specific material weight	t/m ³	1.8	1.8	1.0	1.8	1.8	1.0	1.8	1.8	1.0	1.8	1.8	1.0
A	Dumping height at max. lift height	mm	2,870	2,765	2,660	2,800	2,700	2,550	2,900	2,770	2,606	2,845	2,740	2,505
B	Dump-over height	mm	3,335	3,320	3,320	3,335	3,320	3,330	3,480	3,475	3,475	3,480	3,480	3,476
C	Max. height of bucket bottom	mm	3,530	3,530	3,525	3,530	3,530	3,531	3,680	3,680	3,681	3,680	3,680	3,688
D	Max. height of bucket pivot point	mm	3,775	3,775	3,775	3,775	3,775	3,775	3,930	3,930	3,928	3,930	3,930	3,930
E	Max. operating height	mm	4,860	4,915	5,160	4,960	5,030	5,230	5,170	5,230	5,530	5,260	5,290	5,590
F	Reach at max. lift height	mm	850	900	1,075	935	980	1,120	960	1,015	1,165	1,005	1,050	1,265
G	Digging depth	mm	80	80	80	80	80	80	80	80	80	80	80	80
H	Height above cab	mm	3,200	3,200	3,200	3,200	3,200	3,200	3,250	3,250	3,250	3,250	3,250	3,250
I	Height above exhaust	mm	2,860	2,860	2,860	2,860	2,860	2,860	2,910	2,910	2,910	2,910	2,910	2,910
J	Ground clearance	mm	460	460	460	460	460	460	490	490	490	490	490	490
K	Wheelbase	mm	2,750	2,750	2,750	2,850	2,850	2,850	2,975	2,975	2,975	2,975	2,975	2,975
L	Overall length	mm	6,720	6,835	7,245	6,930	7,035	7,240	7,150	7,280	7,605	7,225	7,335	7,695
	Turning circle radius over outside bucket edge	mm	5,520	5,550	5,620	5,660	5,690	5,840	5,840	5,880	6,045	5,870	5,910	6,100
	Lifting force (SAE)	kN	100	99	98	99	97	96	145	143	135	144	142	132
	Breakout force (SAE)	kN	91	85	83	80	76	73	113	102	96	105	96	81
	Tipping load, straight*	kg	8,310	7,500	7,320	9,180	8,380	8,130	10,210	9,250	9,135	11,040	10,220	9,931
	Tipping load, articulated at 40°*	kg	7,300	6,600	6,430	8,100	7,400	7,180	9,020	8,180	8,060	9,760	9,040	8,760
	Operating weight*	kg	10,600	10,780	11,055	11,100	11,330	11,470	12,755	12,915	13,090	13,320	13,530	13,805
	Tyre sizes		17.5R25 Michelin XHA			17.5R25 Michelin XHA			20.5R25 Michelin XHA2			20.5R25 Michelin XHA2		

* The figures shown here are valid with tyres above, includes all lubricants, a full fuel tank, the ROPS/FOPS cab and the operator. Different tyres and optional equipment will change the operating weight and tipping load.

** Actual bucket capacity may be approx. 10% larger than the calculation according to ISO 7546 standard. The degree to which the bucket can be filled depends on the material – see page 17.

GPB = General purpose bucket (Rehandling bucket)

QH = Quickhitch

LMB = Light material bucket

T = Welded-on tooth holder with add-on teeth

BOCE = Bolt-on cutting edge

Parallel Linkage

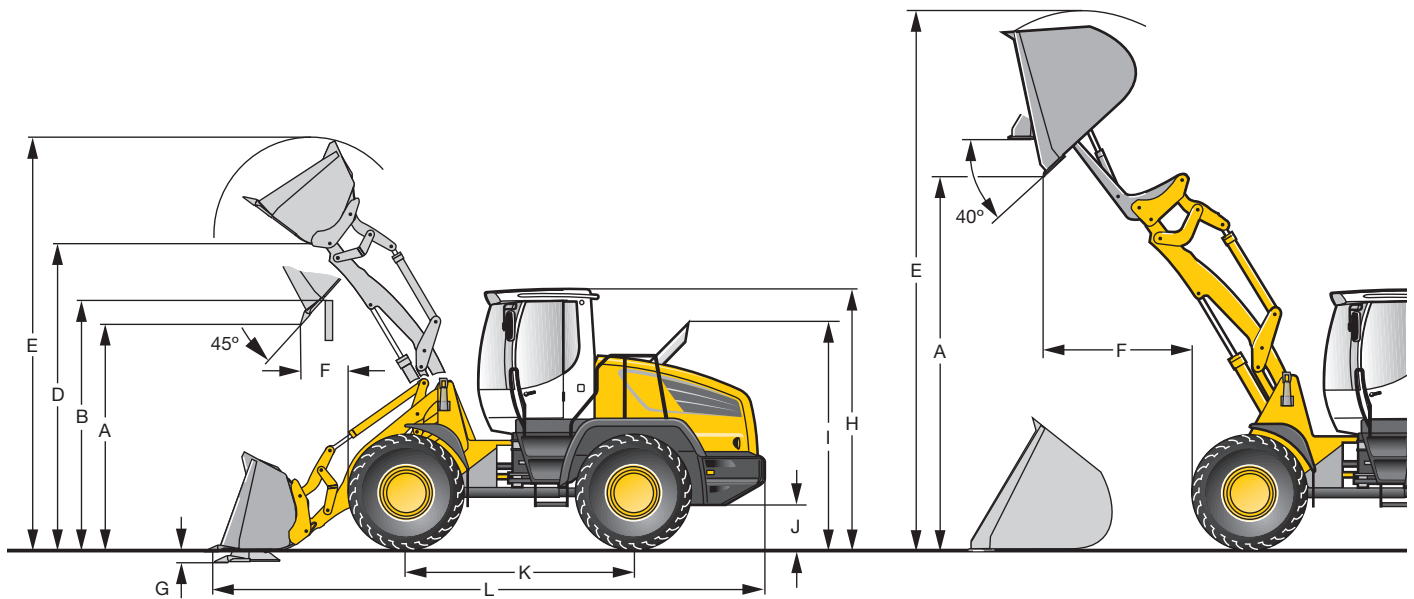

L 524 ^{2plus1}

L 528 ^{2plus1}

L 538 ^{2plus1}

L 542 ^{2plus1}

		LMB	LMB	HDB	LMB	LMB	HDB	LMB	LMB	HDB	LMB	LMB	HDB
		BOCE	BOCE	BOCE	BOCE	BOCE	BOCE	BOCE	BOCE	BOCE	BOCE	BOCE	BOCE
Bucket type		LMB	LMB	HDB	LMB	LMB	HDB	LMB	LMB	HDB	LMB	LMB	HDB
Cutting tools		BOCE	BOCE	BOCE	BOCE	BOCE	BOCE	BOCE	BOCE	BOCE	BOCE	BOCE	BOCE
Bucket capacity according to ISO 7546**	m ³	3.0	5.5	5.0	3.5	6.0	5.5	4.0	6.5	6.0	4.5	7.0	6.7
Bucket width	mm	2,750	2,750	2,700	2,750	2,750	2,700	2,750	2,750	2,700	2,750	2,750	2,950
Specific material weight	t/m ³	1.0	0.5	0.5	1.0	0.5	0.5	1.0	0.5	0.5	1.0	0.5	0.5
A Dumping height at max. lift height	mm	2,630	2,230	4,479	2,550	2,185	4,457	2,520	2,185	4,480	2,450	2,135	4,417
B Dump-over height	mm	3,380	3,380	4,505	3,380	3,380	4,505	3,430	3,430	4,555	3,430	3,430	4,555
C Max. height of bucket bottom	mm	3,595	3,595	3,595	3,595	3,595	3,595	3,645	3,645	3,645	3,645	3,645	3,645
D Max. height of bucket pivot point	mm	3,835	3,835	3,835	3,835	3,835	3,835	3,890	3,890	3,890	3,890	3,890	3,890
E Max. operating height	mm	5,290	5,670	6,500	5,440	5,450	6,630	5,460	5,925	6,755	5,560	5,980	6,820
F Reach at max. lift height	mm	1,220	1,630	1,639	1,305	1,680	1,666	1,300	1,650	1,613	1,370	1,700	1,600
G Digging depth	mm	55	55	55	55	55	55	35	35	35	35	35	35
H Height above cab	mm	3,200	3,200	3,200	3,200	3,200	3,200	3,250	3,250	3,250	3,250	3,250	3,250
I Height above exhaust	mm	2,860	2,860	2,860	2,860	2,860	2,860	2,910	2,910	2,910	2,910	2,910	2,910
J Ground clearance	mm	460	460	460	460	460	460	490	490	490	490	490	490
K Wheelbase	mm	2,750	2,750	2,750	2,850	2,850	2,850	2,975	2,975	2,975	2,975	2,975	2,975
L Overall length	mm	7,255	7,830	7,739	7,475	8,000	7,874	7,765	8,250	8,094	7,865	8,320	8,194
Turning circle radius over outside bucket edge	mm	5,765	5,930	5,925	5,905	6,070	5,934	6,070	6,240	6,193	6,120	6,265	6,340
Lifting force (SAE)	kN	76			75			102			101		
Breakout force (SAE)	kN	63			61			80			76		
Tipping load, straight*	kg	7,686	7,010	6,665	8,718	8,065	7,840	9,092	8,580	8,375	9,969	9,445	9,125
Tipping load, articulated at 40°*	kg	6,754	6,155	5,855	7,698	7,120	6,920	8,019	7,570	7,385	8,793	8,330	8,050
Operating weight*	kg	11,929	12,320	12,715	12,335	12,750	13,145	13,442	13,745	14,220	14,041	14,320	14,910
Tyre sizes		17.5R25 Michelin XHA			17.5R25 Michelin XHA			20.5R25 Michelin XHA2			20.5R25 Michelin XHA2		

* The figures shown here are valid with tyres above, includes all lubricants, a full fuel tank, the ROPS/FOPS cab and the operator. Different tyres and optional equipment will change the operating weight and tipping load.

** Actual bucket capacity may be approx. 10% larger than the calculation according to ISO 7546 standard. The degree to which the bucket can be filled depends on the material – see page 17.

LMB = Light material bucket

HDB = High-Dump bucket

BOCE = Bolt-on cutting edge

Parallel Linkage High Lift

Light Material Bucket

High-Dump Bucket

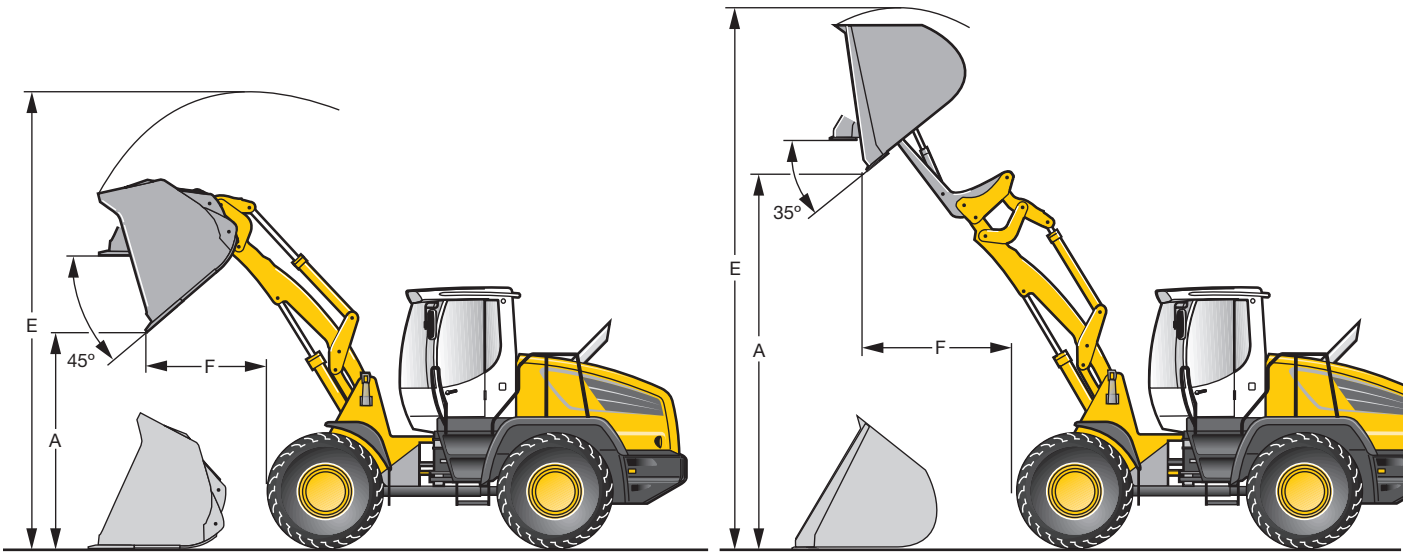

Light Material Bucket with Bolt-On Cutting Edge

		L 524 ^{2plus1}	L 528 ^{2plus1}	L 538 ^{2plus1}	L 542 ^{2plus1}
Bucket capacity	m ³	4.0	4.5	5.0	5.5
Bucket width	mm	2,750	2,750	2,750	2,750
Specific material weight	t/m ³	0.5	0.5	0.5	0.5
A Dumping height at max. lift height	mm	3,050	2,980	2,960	2,855
E Max. operating height	mm	5,950	6,050	6,140	6,250
F Reach at maximum lift height	mm	1,355	1,425	1,404	1,505
L Overall length	mm	8,165	8,365	8,635	8,780
Tipping load, straight*	kg	5,510	6,380	7,020	7,655
Tipping load, articulated at 40°*	kg	4,840	5,635	6,190	6,750
Operating weight*	kg	12,500	12,930	13,905	14,530
Tyre sizes		17.5R25 Michelin XHA	17.5R25 Michelin XHA	20.5R25 Michelin XHA2	20.5R25 Michelin XHA2

High-Dump Bucket with Bolt-On Cutting Edge

		L 524 ^{2plus1}	L 528 ^{2plus1}	L 538 ^{2plus1}	L 542 ^{2plus1}
Bucket capacity	m ³	3.5	4.0	4.5	5.0
Bucket width	mm	2,500	2,700	2,700	2,700
Specific material weight	t/m ³	0.5	0.5	0.5	0.5
A Dumping height at max. lift height	mm	5,260	5,260	5,269	5,246
E Max. operating height	mm	6,915	6,975	7,085	7,160
F Reach at maximum lift height	mm	1,468	1,468	1,446	1,479
L Overall length	mm	8,257	8,357	8,612	8,652
Tipping load, straight*	kg	5,045	5,940	6,485	7,310
Tipping load, articulated at 40°*	kg	4,430	5,245	5,720	6,450
Operating weight*	kg	12,820	13,255	14,320	14,925
Tyre sizes		17.5R25 Michelin XHA	17.5R25 Michelin XHA	20.5R25 Michelin XHA2	20.5R25 Michelin XHA2

* The figures shown here are valid with tyres above, includes all lubricants, a full fuel tank, the ROPS/FOPS cab and the operator. Different tyres and optional equipment will change the operating weight and tipping load.

Attachment

Fork Carrier and Fork

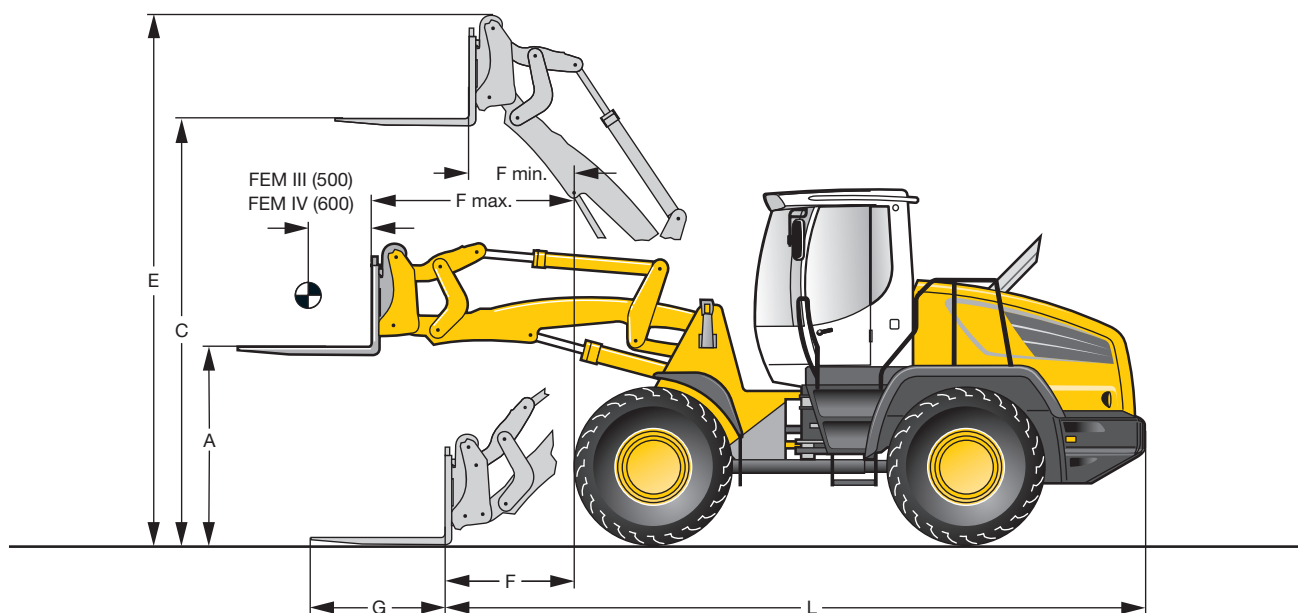

Fork Carrier and Fork with Quick Change Device

L 524 ^{2plus1}

L 528 ^{2plus1}

L 538 ^{2plus1}

L 542 ^{2plus1}

L 538 ^{2plus1}

L 542 ^{2plus1}

	Fork Geometry	FEM III				FEM IV								
		ZK	PK	ZK	PK	ZK	PK	ZK	PK					
A	Lifting height at max. reach	mm	1,690	1,690	1,693	1,693	1,781	1,739	1,780	1,739	1,760	1,715	1,760	1,715
C	Max. lifting height	mm	3,580	3,645	3,592	3,650	3,738	3,697	3,740	3,699	3,710	3,665	3,710	3,665
E	Max. operating height	mm	4,510	4,560	4,513	4,565	4,662	4,612	4,664	4,613	4,695	4,610	4,695	4,610
F	Reach at loading position	mm	975	1,110	969	1,104	939	975	937	974	955	995	955	995
F max.	Max. reach	mm	1,625	1,720	1,619	1,720	1,635	1,635	1,631	1,631	1,615	1,610	1,615	1,610
F min.	Reach at max. lifting height	mm	695	780	698	774	694	695	683	684	675	975	675	975
G	Fork length	mm	1,200	1,200	1,200	1,200	1,200	1,200	1,200	1,200	1,200	1,200	1,200	1,200
L	Length – basic machine without forks	mm	7,290	7,425	7,392	7,527	7,553	7,591	7,552	7,590	7,525	7,570	7,525	7,570
	Tipping load, straight*	kg	5,755	6,315	6,410	7,205	7,225	7,610	7,970	8,355	7,110	7,510	7,860	8,260
	Tipping load, articulated at 40°**	kg	5,055	5,550	5,660	6,360	6,375	6,715	7,030	7,370	6,270	6,620	6,935	7,285
	Recommended payload**	kg	3,035	3,330	3,395	3,820	3,825	4,030	4,220	4,420	3,765	3,975	4,160	4,370
	Recommended payload***	kg	4,045	4,440	4,150 ¹⁾	5,000 ²⁾	5,000 ²⁾	5,000 ²⁾	5,000 ²⁾	5,000 ²⁾	5,020	5,300	5,165 ¹⁾	5,830
	Operating weight*	kg	10,525	11,370	10,905	11,735	12,500	12,690	13,035	13,225	12,736	12,926	13,274	13,464
	Tyre sizes		17.5R25 Michelin XHA		17.5R25 Michelin XHA		20.5R25 Michelin XHA2		20.5R25 Michelin XHA2		20.5R25 Michelin XHA2		20.5R25 Michelin XHA2	

* The figures shown here are valid with tyres above, includes all lubricants, a full fuel tank, the ROPS/FOPS cab and the operator. Different tyres and optional equipment will change the operating weight and tipping load.

** for uneven ground = 60 % of tipping load (articulated at 40°) (according to EN 473-3 and ISO 14397)

*** for smooth surfaces = 80 % of tipping load (articulated at 40°) (according to EN 473-3 and ISO 14397)

1) Payload on forks is limited by tilt cylinder

2) Load capacity for the fork carrier and forks is limited to 5,000 kg

ZK = Z-bar linkage

PK = Parallel linkage

Tipping Load

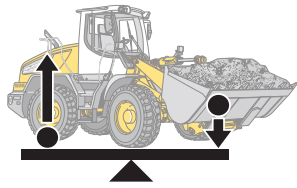

ISO 7546

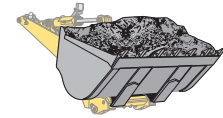

What is tipping load?

Load at centre of gravity of working equipment, so that the wheel loader just begins to tip over the front axle.

This is the most unfavourable static-load position for the wheel loader.

Lifting arms horizontal, wheel loader fully articulated at centre pivot.

Pay load.

The pay load must not exceed 50% of the tipping load when articulated.

This is equivalent to a static stability-margin factor of 2.0.

Bucket capacity.

The bucket volume is determined from the pay load.

$$\text{Pay load} = \frac{\text{Tipping load, articulated}}{2}$$

$$\text{Bucket capacity} = \frac{\text{Pay load (t)}}{\text{Specific bulk weight of material (t/m}^3\text{)}}$$

Bulk Material Densities and Bucket Filling Factors

	t/m ³	%		t/m ³	%		t/m ³	%
Gravel, moist	1.9	105	Clay, natural	1.6	110	Granite	1.8	95
dry	1.6	105	dry	1.4	110	Limestone, hard	1.65	95
wet, 6 – 50 mm	2.0	105	wet	1.65	105	soft	1.55	100
dry, 6 – 50 mm	1.7	105	Clay and gravel, dry	1.4	110	Sandstone	1.6	100
crushed stone	1.5	100	wet	1.6	100	Slate	1.75	100
Sand, dry	1.5	110	Earth, dry	1.3	115	Bauxite	1.4	100
moist	1.8	115	wet excavated	1.6	110	Gypsum, broken	1.8	100
wet	1.9	110	Topsoil	1.1	110	Coke	0.5	110
Gravel and sand, dry	1.7	105	Weathered rock			Slag, broken	1.8	100
wet	2.0	100	50 % rock, 50 % earth	1.7	100	Coal	1.1	110
Sand and clay	1.6	110	Basalt	1.95	100			

Tyres



	Size and tread code		Change of operating weight kg	Width over tyres mm	Change in vertical dimensions mm	Use
L 524^{2plus1} / L 528^{2plus1}						
Bridgestone	17.5R25 VMT	L3	+ 84	2,450	+ 21	Gravel
Bridgestone	17.5R25 VSDL	L5	+ 640	2,450	+ 57	Stone, Recycling
Goodyear	17.5R25 RT-3B	L3	+ 168	2,470	+ 21	Gravel
Goodyear	17.5R25 RL-5K	L5	+ 704	2,470	+ 42	Industry, Stone
Michelin	17.5R25 XTLA	L2	- 68	2,470	- 6	Gravel, Earthworks
Michelin	17.5R25 XHA	L3	0	2,460	0	Gravel
Michelin	17.5R25 XLD D2A	L5	+ 420	2,480	+ 37	Stone, Recycling
Michelin	17.5R25 X-MINE D2	L5	+ 608	2,480	+ 54	Stone, Recycling
L 538^{2plus1} / L 542^{2plus1}						
Bridgestone	20.5R25 VMT	L3	+ 174	2,470	- 6	Gravel
Bridgestone	20.5R25 VSDL	L5	+ 672	2,470	+ 36	Stone, Scrap
Goodyear	20.5R25 RL-5K	L5	+ 624	2,490	+ 47	Industry, Stone
Goodyear	20.5R25 RT-3B	L3	+ 16	2,480	+ 5	Gravel
Goodyear	20.5R25 TL-3A+	L3	- 16	2,480	+ 5	Gravel, Earthworks
Goodyear	20.5R25 GP-4D	L4	+ 328	2,470	+ 18	Sand, Gravel, Industry
Michelin	20.5R25 XHA2	L3	0	2,480	0	Gravel
Michelin	20.5R25 XLD D2A	L5	+ 428	2,490	+ 30	Stone, Mining spoil, Recycling
Michelin	20.5R25 X-Mine D2	L5	+ 696	2,480	+ 43	Stone, Scrap

Before operating the vehicle with tyre foam filling or tyre protection chains, please discuss this with the Liebherr-Werk Bischofshofen GmbH.

The Liebherr Wheel Loaders

Stereoloader



		L 506 ^{Stereo}	L 507 ^{Stereo}	L 508 ^{Stereo}	L 509 ^{Stereo}	L 510 ^{Stereo}	L 514 ^{Stereo}
Tipping load	kg	3,231	3,501	3,824	4,225	4,581	5,680
Bucket capacity	m ³	0.8	0.9	1.0	1.1	1.2	1.5
Operating weight	kg	5,120	5,240	5,480	6,080	6,250	8,350
Engine output	kW/HP	46/63	48/65	48/65	60/82	60/82	72/98

Wheel Loader



		L 524 ^{2plus1}	L 528 ^{2plus1}	L 538 ^{2plus1}	L 542 ^{2plus1}	L 550 ^{2plus2}
Tipping load	kg	7,300	8,100	9,020	9,760	11,650
Bucket capacity	m ³	2.0	2.2	2.5	2.7	3.2
Operating weight	kg	10,600	11,100	12,755	13,320	16,525
Engine output	kW/HP	86/117	86/117	105/143	105/143	129/175

Wheel Loader



		L 556 ^{2plus2}	L 566 ^{2plus2}	L 576 ^{2plus2}	L 580 ^{2plus2}	L 586 ^{2plus2}
Tipping load	kg	13,140	15,550	17,200	18,000	20,430
Bucket capacity	m ³	3.6	4.0	4.5	5.0	5.5
Operating weight	kg	17,270	22,500	24,260	24,580	31,380
Engine output	kW/HP	140/191	190/259	200/272	200/272	250/340

07.10

Environmental protection can help you earn money!

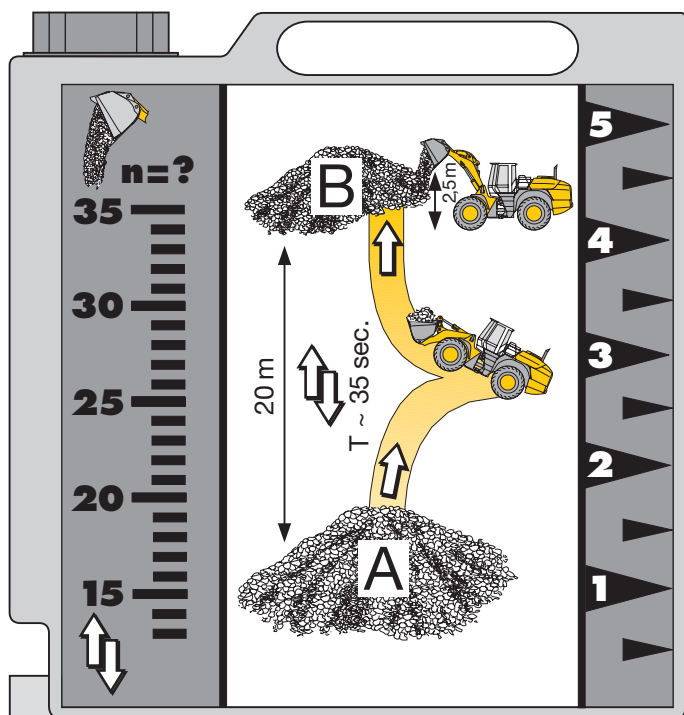

The Liebherr Standard Consumption Test - easy to reproduce and practical.

Every Liebherr dealer will provide you with this measuring-tank kit free of charge or, on request, will carry out the standard fuel consumption test on your premises. It's so easy: you simply determine the number of loading cycles that can be carried out with 5 litres of diesel. The material is taken from pile A and carried over a distance of 20 metres to point B. The time needed for each working cycle should be 35 seconds. Discharge at point B should take place from a height of 2.5 m. The working cycles continue until the 5 litres of diesel in the external measuring tank have been used up. The loader's fuel consumption per operating hour is calculated as follows:

$$\frac{400}{\text{Number of loading cycles}} = \text{consumption per hour}$$

Values for the Liebherr Wheel Loaders

	Numbers of working cycles	Litres/100 tons	Litres/hour
L 524 2plus1: 2.0 m ³	n = 44	3.2	9.1
L 528 2plus1: 2.2 m ³	n = 43	2.9	9.3
L 538 2plus1: 2.5 m ³	n = 36	2.9	11.1
L 542 2plus1: 2.7 m ³	n = 35	2.7	11.4
L 550 2plus2: 3.2 m ³	n = 31	2.6	12.9
L 556 2plus2: 3.6 m ³	n = 27	2.9	14.5
L 566 2plus2: 4.0 m ³	n = 22	2.9	18.2
L 576 2plus2: 4.5 m ³	n = 21	2.9	19.1
L 580 2plus2: 5.0 m ³	n = 20	2.8	20.0
L 586 2plus2: 5.5 m ³	n = 14	3.2	28.5*

* Equipped with L5 tires and 5.5 m³ HD bucket

Equipment



Basic Machine

	524 2plus1	528 2plus1	538 2plus1	542 2plus1
Automatic central lubrication system	•	•	•	•
Battery master switch	•	•	•	•
Fuel particle filter	•	•	•	•
Electronical theft protection	•	•	•	•
Automatic travel mode	•	•	•	•
Headlights	•	•	•	•
Ride control	•	•	•	•
Fluff trap for radiator	•	•	•	•
Large-mesh radiator	•	•	•	•
Pre-heat system for cold starting	•	•	•	•
Combined inching-braking system	•	•	•	•
Fuel tank steel version	•	•	•	•
Multi-disc limited slip differentials in both axles	•	•	•	•
LiDAT Standard (Liebherr Data Transfer System)	•	•	•	•
Liebherr bio degradable hydraulic oil	•	•	•	•
Liebherr travel gear	•	•	•	•
Liebherr shock absorbing element	•	•	•	•
Air cleaner system with pre-filter	•	•	•	•
Reversible fan drive	•	•	•	•
Emergency steering system	•	•	•	•
Back-up alarm	•	•	•	•
Lockable doors, service flap and engine hood	•	•	•	•
Toolbox with toolkit	•	•	•	•
Towing hitch	•	•	•	•
Two working area lights at rear	•	•	•	•
Two tail lights	•	•	•	•
20 km/h speed limiting	•	•	•	•



Operator's Cab

	524 2plus1	528 2plus1	538 2plus1	542 2plus1
Storage box	•	•	•	•
Lockable storage compartment	•	•	•	•
Ashtray	•	•	•	•
Operator's package	•	•	•	•
Operator's seat – adjustable in 6 ways	•	•	•	•
Operator's seat – air sprung with seat heating	•	•	•	•
Fire extinguisher 2 kg	•	•	•	•
Cup holder	•	•	•	•
Height-adjustable steering column	•	•	•	•
Horn	•	•	•	•
Joystick steering	•	•	•	•
Floor mat	•	•	•	•
Clothes hook	•	•	•	•
Air conditioning system	•	•	•	•
LED operating spotlight, front/rear	•	•	•	•
Liebherr-joystick control – adjustable	•	•	•	•
Radio set	•	•	•	•
Provision for radio including loudspeaker	•	•	•	•
Monitoring area to the rear with camera	•	•	•	•
Interior rear-view mirror	•	•	•	•
Amber beacon	•	•	•	•
Soundproof ROPS/FOPS cab with tinted safety glass front windscreen, heatable rear window	•	•	•	•
Wash/wipe system for windscreen and rear window	•	•	•	•
Sliding window	•	•	•	•
Protective ventilation system	•	•	•	•
Windscreen guard	•	•	•	•
Sun visor	•	•	•	•
Dust filter system	•	•	•	•
Plug 12 V	•	•	•	•
First aid kit	•	•	•	•
Adjustable steering column	•	•	•	•
Four working area lights at front	•	•	•	•
Hot water heater with defroster and recirculated-air system	•	•	•	•
Wide angle mirror	•	•	•	•
Xenon working lights front	•	•	•	•
Two or four working area lights rear	•	•	•	•



Instruments for:

	524 2plus1	528 2plus1	538 2plus1	542 2plus1
Timer for hours of operation	•	•	•	•
Flashing turn indicators	•	•	•	•
Diagnosis system	•	•	•	•
Forward – reverse travel	•	•	•	•
Travel speed ranges and gear selected	•	•	•	•
High-beam headlights	•	•	•	•
Fuel reserve	•	•	•	•
Engine oil temperature	•	•	•	•

• = Standard, + = Option

All illustrations and data may differ from standard equipment. Subject to change without notice.

Reverse travel	•	•	•	•
Speedometer	•	•	•	•
Clock	•	•	•	•
Diesel engine pre-heat	•	•	•	•
Forward travel	•	•	•	•



Warning Lights for:

	524 2plus1	528 2plus1	538 2plus1	542 2plus1
Battery charge	•	•	•	•
Flow through emergency steering system	•	•	•	•
Parking brake	•	•	•	•
Hydraulic oil temperature	•	•	•	•
Air cleaner blockage	•	•	•	•
Engine oil pressure	•	•	•	•
Engine overheat	•	•	•	•



Audible Warnings for:

	524 2plus1	528 2plus1	538 2plus1	542 2plus1
Overheat of hydraulic fluid	•	•	•	•
Engine oil pressure	•	•	•	•
Engine overheat	•	•	•	•
Emergency steering system	•	•	•	•



Function Keys for:

	524 2plus1	528 2plus1	538 2plus1	542 2plus1
Working lights rear	•	•	•	•
Working lights front	•	•	•	•
Electronic tractive force adaptation	•	•	•	•
Speed range selection	•	•	•	•
Headlights	•	•	•	•
Ride control	•	•	•	•
Parking brake	•	•	•	•
Fresh air or recirculated air	•	•	•	•
Blower	•	•	•	•
Heater	•	•	•	•
Hoist kick-out	•	•	•	•
Air conditioning	•	•	•	•
Creep speed	•	•	•	•
Mode switch	•	•	•	•
Amber beacon	•	•	•	•
Automatic bucket positioner	•	•	•	•
Wash/wipe system for rear window	•	•	•	•
Float position	•	•	•	•
Road travel	•	•	•	•
Hazard warning flashers	•	•	•	•
Additional hydraulics	•	•	•	•



Equipment

	524 2plus1	528 2plus1	538 2plus1	542 2plus1
Automatic hoist kick out – adjustable	•	•	•	•
Automatic bucket positioner – adjustable	•	•	•	•
Fork carrier and lift forks	•	•	•	•
High-dump bucket	•	•	•	•
Hydraulic quick-change device – Parallel linkage	•	•	•	•
Hydraulic quick-change device – Z-bar linkage	•	•	•	•
Hydraulic servo control of working hydraulics	•	•	•	•
Comfort control	•	•	•	•
Loading buckets with and without teeth, or bolt-on cutting edge	•	•	•	•
Country-specific versions	•	•	•	•
Light material bucket	•	•	•	•
Parallel linkage	•	•	•	•
Parallel linkage “High Lift”	•	•	•	•
Float position	•	•	•	•
Z-bar linkage	•	•	•	•
3rd hydraulic control circuit	•	•	•	•
3rd and 4th hydraulic control circuits	•	•	•	•

524-542 03.10

The Liebherr Group of Companies

Wide product range

The Liebherr Group is one of the largest construction equipment manufacturers in the world. Liebherr's high-value products and services enjoy a high reputation in many other fields, too. The wide range includes domestic appliances, aerospace and transportation systems, machine tools and maritime cranes.

Exceptional customer benefit

Every product line provides a complete range of models in many different versions. With both their technical excellence and acknowledged quality, Liebherr products offer a maximum of customer benefits in practical application.

State-of-the-art technology

To provide consistent, top quality products, Liebherr attaches great importance to each product area, its components and core technologies. Important modules and components are developed and manufactured in-house, for instance the entire drive and control technology for construction equipment.

Worldwide and independent

Hans Liebherr founded the Liebherr family company in 1949. Since that time, the enterprise has steadily grown to a group of more than 100 companies with over 32,000 employees located on all continents. The corporate headquarters of the Group is Liebherr-International AG in Bulle, Switzerland. The Liebherr family is the sole owner of the company.

www.liebherr.com



Printed in Germany by Eberl RG-BK-RP LBH/PM 10354047-2-07.10_enGB

Liebherr-Werk Bischofshofen GmbH

Postfach 49, A-5500 Bischofshofen

☎ +43 50809 1-0, Fax +43 50809 11385

www.liebherr.com, E-Mail: info.lbh@liebherr.com