

GENERAL DATA

CRANE CAPACITY	77 ton at 10 feet (70t at 3.0m)
BOOM	4-section, 37' 6" – 111' 6" (11.4 m – 34.0 m)
DIMENSION	
Overall Length	48' 3" (14.94 m)
Overall Width (tracks extended)	18' 8" (5.69 m)
Overall Width (tracks retracted)	12' 6" (3.81 m)
Overall Width (tracks removed)	9' 10" (3.0 m)
Overall Height	10' 7" (3.22 m)
MASS	
Gross Vehicle Mass (Standard Equipment Package)	137,554 LB (62,241 kg)
PERFORMANCE	
Travel Speed	0.6 mph – 1.7 mph (1.0 km/h – 2.8 km/h)
Gradability	68%

CRANE SPECIFICATION

MODEL

15010

CAPACITY

77 ton at 10 feet (70t at 3.0m)

BOOM

4-section full power synchronized telescoping boom. Synchronized telescoping system consists of two double acting hydraulic cylinders with load holding valves and extension and retraction cables.

- Retracted Length: 37' 6" (11.4m)
- Extended Length: 111' 6" (34 m)
- Elevating Angles: -1° to 78°
- Boom Head: Seven, 19 inch (483 mm) diameter cast nylon sheaves on heavy-duty roller bearings. (5 load bearing and 2 lead in sheaves)
- Extension Time: 102 s
- Elevating Time: 64 s

AUXILIARY BOOM HEAD

Quick reeve, single 19 inch (483 mm) diameter high-strength, cast nylon sheave mounted on a heavy-duty roller bearing.

- Hook Block: 80 ton (72.5 t) hook block - Five 19 inch (483 mm) diameter sheaves mounted on heavy duty roller bearings with swivel hook and safety latch.
- Headache Ball: 12 ton (11t) ball includes a swivel hook with a safety latch

COUNTERWEIGHT

Total 35,000 LB (two pieces at 17,500 lbs each)
(15,875 kg - (Two pieces at 7,938 kg each))

WINCHES

Planetary geared two-speed winch includes a bent axis hydraulic motor, multi-disc internal brake and counterbalance valve. Drum rotation indicator is included (complete winch performance specs on Page 4)

- Main Winch
 - Rope Diameter and Length: ¾" x 700 ft (19mm x 213m)
 - Single line pull: 17,960 lb (79.9 kN)(first layer)
 - Single line speed: 192 ft/min (59 m/min)(4th layer)
- Auxiliary Winch
 - Rope Diameter and Length: ¾" x 350 ft (19mm x 107m)
 - Single line pull: 15,360 lb (68.3 kN) (first layer)
 - Single line speed: 243 ft/min (74.1 m/min) (at the 4th layer)

TRAVEL

Each side frame contains a pilot controlled, two-speed track drive with hydraulic axial piston motor and parking brake. Travel system provides skid steering and counter rotation.

- Low travel speed: 0.6 mph (1.0 km/h)
- High travel speed: 1.7 mph (2.8 km/h)
- Gradeability (unladen): 68%

SWING

Gear motor driving a planetary gear reducer with a shaft mounted pinion, external gear shear ball slew bearing bolted to the superstructure and the carbody allows the superstructure to rotate 360°

- Swing Speed: 0 - 2.2 rpm
- Swing Parking Brake: Spring applied failsafe brake with hydraulic release that is controlled from the operators cab
- Swing Service Brake: Hydraulically applied, controlled through foot actuated pedal
- House Lock System: 2-position, manually pinned

LOAD MOMENT INDICATOR

Standard Rated Capacity Limiter and Anti-Two Block system

- Control function shutdown. Audible and visual warnings
- LCD screen provides a continuous display of working boom length, boom angle, working load radius, tip height, parts-of-line (operator set), machine track configuration, relative load moment, maximum permissible load and actual load.
- Anti-two block weight allows quick reeving of hook block

FRAME

The frame is an all-steel, welded structure, precision machined to accept attachment of the boom and swing components.

OPERATORS CAB

Fully-enclosed, air conditioned all-steel modular cab with lockable swinging door, acoustical lining, anti-slip floor and tinted safety glass.

- Cab tilts 20°.
- Rear view cameras are appropriately located as are three remote control work lights.
- Vent window in the rear of the cab.
- Grab bars and steps are located for easy access to the cab.
- Defroster, heater, circulating fan
- 2-speed windshield wiper, top glass wiper
- Six-way adjustable fabric seat with headrest, seat belt
- Dome light
- Dry-chemical fire extinguisher
- Four-way electronic armrest mounted joysticks control swing, boom extend, main winch, auxiliary winch and boom hoist. Electronic foot pedals control the travel and swing service brake functions.
- Selectable control modes for: Fine Control, Auger, and hand control of travel functions.
- Seat and armrest termination switches immediately disable all hydraulic functions as the operator rises from the seat or lifts the left hand armrest.

Dash instrumentation: tachometer, voltmeter, oil pressure gauge, temperature gauge, hour meter and fuel gauge. Indicators are provided for crane level, load moment, drum rotation, air filter restriction, hydraulic oil temperature and filter restriction, engine oil pressure and temperature.

ENGINE

- Make/ Model: Cummins QSB 6.7
- Type: 6 Cylinder, Water cooled, 4 Cycle
- Aspiration: Turbocharged and Aftercooled
- Max.Output: 260 hp (194 kw) @ 2200 RPM
- Max Torque: 728 Lb-ft (987 Nm) @ 1500 RPM
- Piston Disp: 6.7 liter
- Bore x Stroke: 107mm x 124mm
- Emission Cert: U.S. EPA Tier 3, Euromot Stage IIIA
- Alternator: 130 amp

ELECTRICAL SYSTEM

12 VDC

FUEL SYSTEM

- Capacity: 105 gallon (397 liter)
- Filtration: Inline fuel/water separator and engine mounted fuel filter

SIDE FRAMES

Two welded steel side frames are paired with a track group. The side frames extend and retract hydraulically and are controlled from the cab.

- Track Rollers: Two top and twelve bottom sealed rollers on each track frame Idler: Oil filled, self lubricating with spring type tensioner
- Track Shoes: 36 inch (900 mm), 3-bar semi grouser

HYDRAULIC SYSTEM

- Hydraulic Pumps: Two high pressure, variable axial piston pumps with load sense and power limiting control for crane functions. One variable axial piston pump for cooling loop
- Directional Valves: Multiple pressure and flow compensated valves with integrated relief valves controlled by hydraulic pilot signals.
- Pump output: 154 gpm (583 l/min) @ 2100 RPM engine speed. 4,800 psi (330 bar) maximum pressure
- Reservoir: 300 gallon (1,136 liter) capacity, spin-on filler/ breather, sight gauge, cleanout, and sump drain.
- Filtration: 5 micron, full flow tank mounted return filters with electrical clogging indicator. 5 micron pilot oil in-line pressure filter
- Diagnostic Ports: Provided for system, load sense, and pilot pressure

OPTIONAL EQUIPMENT

- Boom Extension: Lattice type, swing away
 - Length: 30 feet (9.1m)
 - Head: Two, 19-inch (483 mm) diameter cast nylon sheaves on heavy-duty roller bearings
 - Max. Lifting Height: 142 ft (43.3 m)
- Boom Jib: Lattice type, swing away, stores along boom extension
 - Length: 20 feet (6.1m)
 - Offset Angles: 15° & 30°
 - Max. Lifting Height: 162 feet (49.4 m)
- 50 ton (45t) hook block - Three 18 inch (457 mm) steel sheaves, swivel hook & safety latch
- Carbody Jack System: Hydraulic cylinder jack system and pendant control to facilitate quick removal of track frames for 9' 10" (3.0m) shipping width.
- Track Shoes: 30 inch (760 mm) 3-bar semi grouser
- Track Shoes: 31.5 inch (800 mm) flat shoe
- Auger Ready Package: Includes hoses, fasteners and stowage bracket assembly mounted to the base section of the boom with a flow capability of 34 gpm (130 l/min)
- Complete Auger Package: Adds a two speed auger motor/gear box and one 60 inch (1.52 m) kelly bar to the Auger Ready Package.
- Tool Circuit: Provides 5 gpm (23 l/min) and 10 gpm (45 l/min) at 2,500 PSI (176 bar) through a 50 foot (15.2m) twin hose reel with quick disconnect fittings to operate open center tools.
- Free Fall Hoists: Winches are available in controlled free fall configurations.
- Cold Weather Packages: Cold weather options are available for operation to -40°C (Consult factory for application support)
- Work Platform: Model WP750 – 36 in x 72 in (0.9m x 1.8m) , all steel, welded, two person platform with maximum capacity of 750 lbs (340 kg).
- Pole Claw: Heavy-duty pole claw with hydraulic clamp and tilt.
- Radio control package.
- Rotation resistant wire rope.
- Access Walkways.

MAIN WINCH

Planetary geared two-speed winch includes a bent axis, variable displacement hydraulic motor and a multi-disc internal brake.
Wire Rope: 700 ft (213 m) 3/4 in (19 mm) 6 x 37 EIPS, IWRC, RRL. Line pulls are not based on wire rope strength. Drum rotation indicator is standard.

Rope Layer	Maximum Line Pull		Full Load Line Speed		High Line Speed		Layer		Total	
	lb	kN	ft/min	m/min	ft/min	m/min	ft	m	ft	m
1	17,960	79.9	149	45	336	102	109	33	109	33
2	16,400	72.9	164	50	368	112	119	36	228	69
3	15,090	67.1	178	54	400	122	130	40	358	109
4	13,970	62.1	192	59	432	132	140	43	498	152
5	13,010	57.9	206	63	464	141	153	46	649	198
6	12,170	54.1	221	67	496	151	161	49	810	247

AUXILIARY WINCH

Planetary geared two-speed winch includes a bent axis, variable displacement hydraulic motor and a multi-disc internal brake.
Wire Rope: 350 ft (107 m) 3/4 in (19 mm) 6 x 37 EIPS, IWRC, RRL. Line pulls are not based on wire rope strength. Drum rotation indicator is standard.

Rope Layer	Maximum Line Pull		Full Load Line Speed		High Line Speed		Layer		Total	
	lb	kN	ft/min	m/min	ft/min	m/min	ft	m	ft	m
1	15,360	68.3	175	53	392	119	64	20	64	20
2	13,590	60.5	197	60	444	135	72	21	136	41
3	12,180	54.2	220	67	495	151	80	25	216	66
4	11,040	49.1	243	74	546	166	89	27	305	93
5	10,100	44.9	266	81	597	182	97	30	402	123

MACHINE WEIGHTS

LB

KG

STANDARD CRANE WITH 4 SECTION 111 ft 6 in (33.99 m) BOOM, AUXILIARY WINCH, 80 TON HOOK BLOCK, 12 TON HEADACHE BALL, 2 PIECE COUNTERWEIGHT & 36 in (914 mm) TRACK SHOES	137,554	62,242
Crane Less Counterweight and Track Frames	62,150	28,122
Counterweight, 2 Pieces at 17,500 Lb each	35,000	15,837
Track Frames, 2 pieces at 18,000 LB each	36,000	16,290
80 ton Hook Block	1,825	828
12 ton Headache Ball	404	183

OPTIONAL EQUIPMENT

LB

KG

Alternative Boom 54 ft (16.46 m) three section boom in place of standard boom**	-8,300	-3,756
Auxiliary Winch with standard rope	960	434
50 ton Hook Block	1,100	498
30 ft (9.1m) Lattice Extension	1,700	769
20 ft (6.1m) Jib	700	317
Auxiliary Nose Sheave	210	95
Auger Ready Package	440	199
Complete Auger Package	1,520	688
60 in Kelly Bar	120	54
72 in Kelly Bar	140	63
Heavy Duty Pole Claw	830	375

* Deduction from Standard Crane Weight

15010

77 Ton Telescopic Boom Crawler Crane

SPECIFICATION SHEET NO. 417-08/10

DIMENSIONS

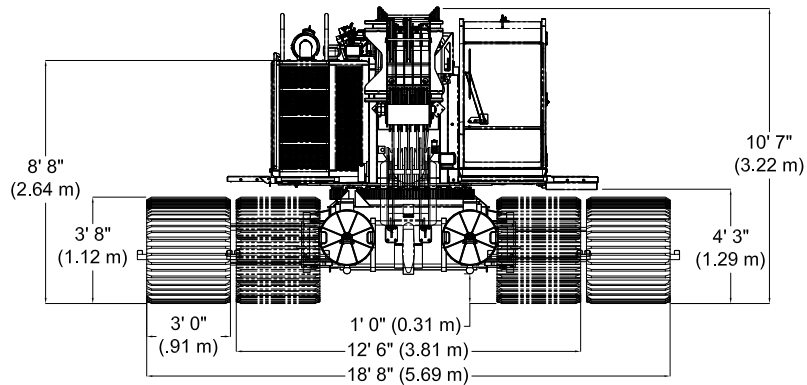
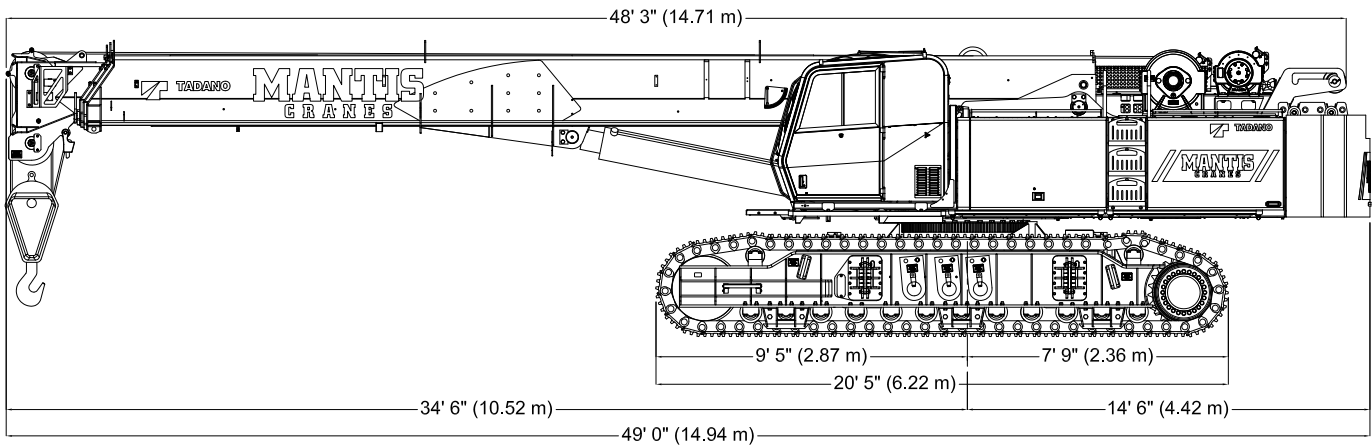

WIDTHS, WEIGHTS, AND GROUND PRESSURES*

Shoe Width	Overall Width		Area	Ground Pressure	Working Weight
	Retracted	Extended			
30 in (762 mm)	12 ft 0 in (3.66 m)	18 ft 2 in (5.54 m)	12,360 in ² (7.97 m ²)	11.0 psi (0.77 kg/cm ²)	135,730 lb (61,419 kg)
36 in (900 mm)	12 ft 6 in (3.81 m)	18 ft 8 in (5.69 m)	14,850 in ² (9.57 m ²)	9.3 psi (0.65 kg/cm ²)	137,554 lb (62,241 kg)

* Crane equipped with: 111 ft 6 in boom, extension, jib, 75 ton hook block and 12 ton headache ball

15010

77 Ton Telescopic Boom Crawler Crane

SPECIFICATION SHEET NO. 417-08/10

TRANSPORT DIMENSIONS

Track Frames:
2 Pieces
18,000 lb (8,165 kg) each

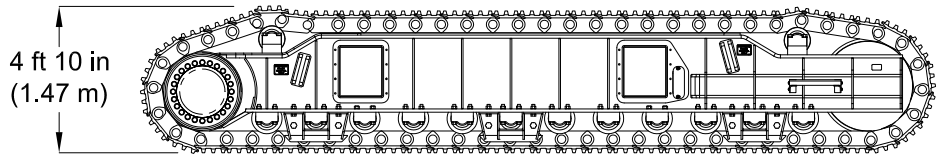
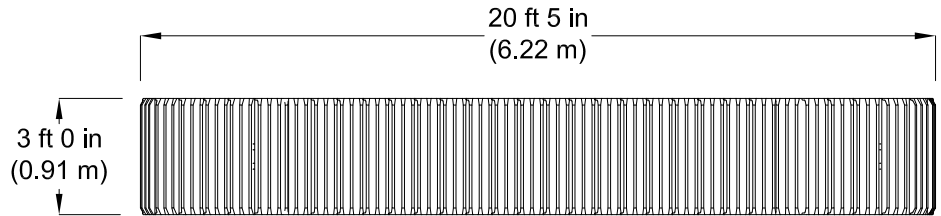

Front Counterweight:
1 Piece
17,500 lb (7,938 kg)

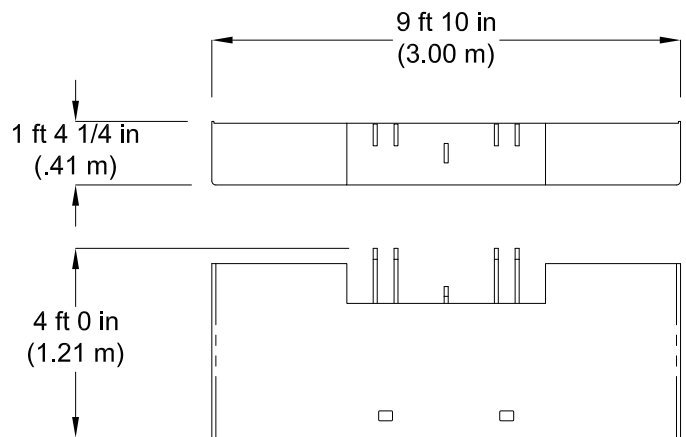

Back Counterweight
1 Piece
17,500 lb (7,938 kg)

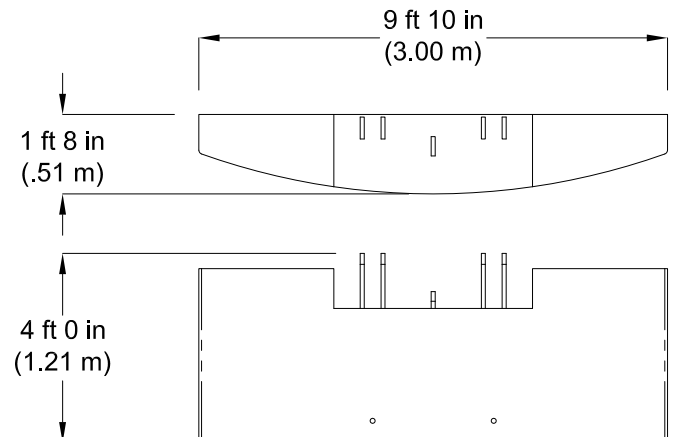

111 FT 6 IN MAIN BOOM, 30 FT EXTENSION & 20 FT JIB

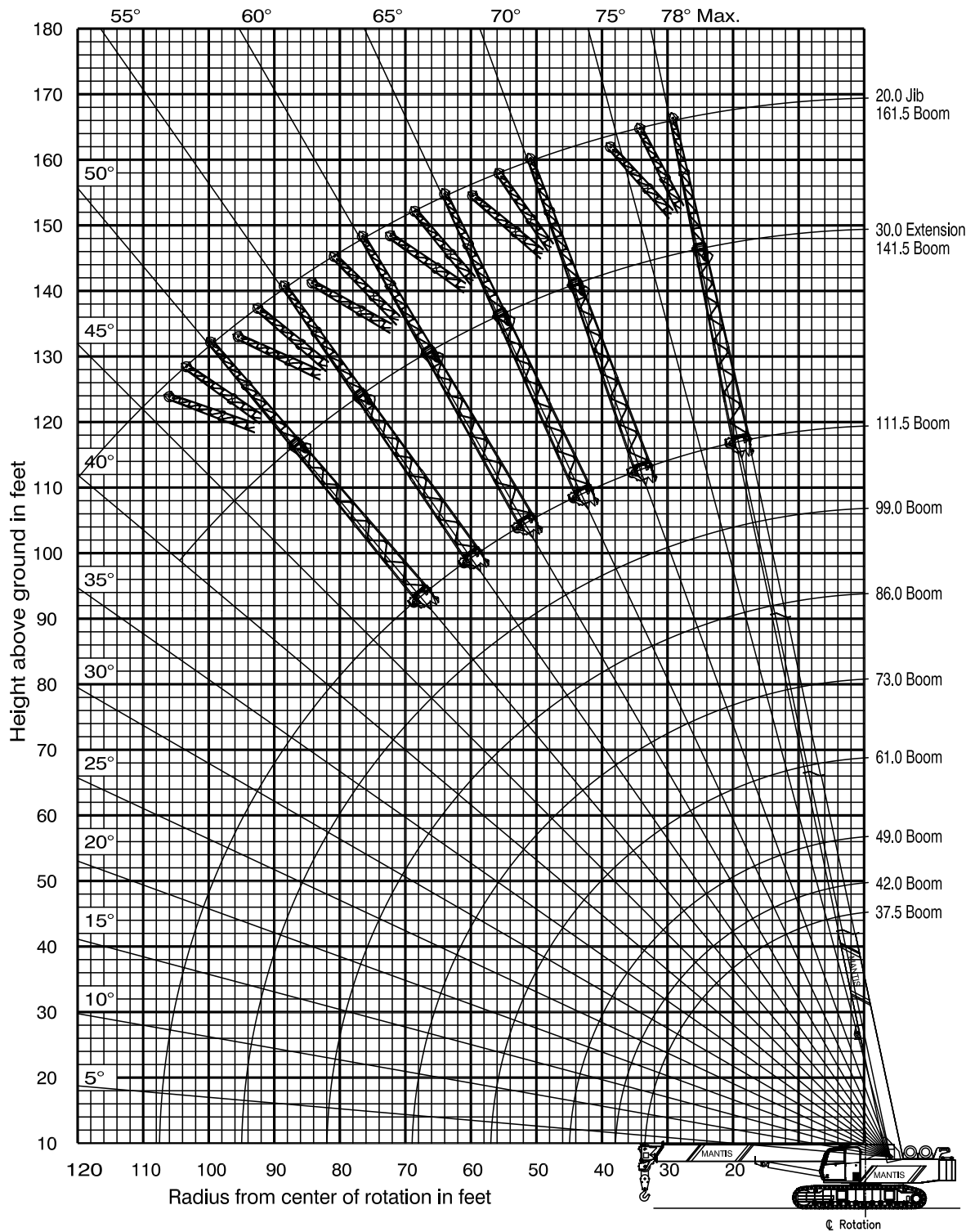

LOAD CHARTS

360 DEGREE RATING - LOADS IN lb x 1000

MAIN BOOM with TRACKS FULLY EXTENDED									
35,000 lb COUNTERWEIGHT									
RADIUS (ft)	MAIN BOOM LENGTH (ft)								RADIUS (ft)
	37.5	45.4	53.3	61.2	73.8	86.4	99.0	111.6	
10	154.0	107.5	105.0	103.0					10
12	136.5	104.0	100.0	90.0					12
15	114.0	102.0	94.0	82.0	64.5				15
20	81.8	81.0	79.0	68.0	59.0	51.0	46.0		20
25	59.7	59.4	59.0	58.7	50.0	42.0	38.5	36.0	25
30	44.2	44.0	43.7	43.4	44.5	36.8	33.2	31.0	30
35		34.2	33.9	33.7	34.8	34.3	29.0	26.7	35
40		32.6	27.2	27.0	28.0	28.6	25.5	23.0	40
45			22.3	22.0	23.1	23.6	24.0	21.9	45
50				18.3	19.3	19.8	20.4	19.7	50
55				15.3	16.3	16.8	17.4	17.5	55
60					13.9	14.4	15.0	15.0	60
65					12.0	12.4	13.0	13.0	65
70						10.8	11.3	11.4	70
75						9.3	9.9	9.9	75
80						8.1	8.6	8.7	80
85							7.6	7.6	85
90							6.6	6.7	90
95							5.8	5.9	95
100								5.1	100
105								4.5	105

NOTE: Capacities appearing above the bold line are based on structural strength; tipping should not be relied upon as a capacity limitation.
 Capacities appearing below the bold line are based on stability and do not exceed 75% of tipping.

LOAD CHARTS

360 DEGREE RATING - LOADS IN lb x 1000

MAIN BOOM with TRACKS FULLY EXTENDED									
17,500 lb COUNTERWEIGHT									
RADIUS (ft)	MAIN BOOM LENGTH (ft)								RADIUS (ft)
	37.5	45.4	53.3	61.2	73.8	86.4	99.0	111.6	
10	154.0	107.5	105.0	103.0					10
12	136.5	104.0	100.0	90.0					12
15	114.0	102.0	94.0	82.0	64.5				15
20	63.6	64.1	63.9	63.3	59.0	51.0	46.0		20
25	42.3	42.7	42.6	42.1	43.9	42.0	38.5	36.0	25
30	30.5	30.9	30.8	30.4	32.1	33.2	33.2	31.0	30
35		23.5	23.4	23.0	24.6	25.7	26.2	26.5	35
40		22.2	18.3	17.9	19.4	20.5	20.9	21.3	40
45			14.5	14.1	15.6	16.7	17.1	17.4	45
50				11.3	12.7	13.8	14.2	14.5	50
55				9.0	10.5	11.5	11.9	12.2	55
60					8.6	9.6	10.0	10.3	60
65					7.1	8.1	8.5	8.8	65
70						6.8	7.2	7.5	70
75						5.7	6.1	6.4	75
80						4.8	5.2	5.4	80
85							4.4	4.6	85
90							3.6	3.9	90
95							3.0	3.3	95
100								2.7	100
105								2.2	105

NOTE: Capacities appearing above the bold line are based on structural strength; tipping should not be relied upon as a capacity limitation.
 Capacities appearing below the bold line are based on stability and do not exceed 75% of tipping.

LOAD CHARTS

360 DEGREE RATING - LOADS IN lb x 1000

MAIN BOOM with TRACKS FULLY EXTENDED									
NO COUNTERWEIGHT									
RADIUS (ft)	MAIN BOOM LENGTH (ft)								RADIUS (ft)
	37.5	45.4	53.3	61.2	73.8	86.4	99.0	111.6	
10	143.0	107.5	105.0	103.0					10
12	119.0	104.0	100.0	90.0					12
15	80.0	79.6	79.3	78.8	64.5				15
20	43.5	43.3	43.1	42.7	44.1	44.9	45.8		20
25	28.2	28.0	27.9	27.6	28.7	29.4	30.3	31.0	25
30	19.8	19.6	19.5	19.3	20.3	20.9	21.7	22.4	30
35		14.3	14.2	14.0	15.0	15.6	16.3	16.9	35
40		13.4	10.6	10.4	11.3	11.9	12.6	13.2	40
45			7.9	7.7	8.6	9.1	9.8	10.4	45
50				5.7	6.5	7.1	7.7	8.3	50
55				4.0	4.9	5.4	6.1	6.6	55
60					3.6	4.1	4.8	5.3	60
65					2.5	3.0	3.7	4.2	65
70						2.1	2.7	3.3	70
75						1.3	2.0	2.5	75
80						NR	1.3	1.8	80
85							NR	1.2	85
90							NR	NR	90
95							NR	NR	95
100								NR	100
105								NR	105

NOTE: Capacities appearing above the bold line are based on structural strength; tipping should not be relied upon as a capacity limitation.
 Capacities appearing below the bold line are based on stability and do not exceed 75% of tipping.

LOAD CHARTS

360 DEGREE RATING - LOADS IN lb x 1000

MAIN BOOM with TRACKS RETRACTED									
17,500 lb COUNTERWEIGHT									
RADIUS (ft)	MAIN BOOM LENGTH (ft)								RADIUS (ft)
	37.5	45.4	53.3	61.2	73.8	86.4	99.0	111.6	
10.0	130.5	107.5	105.0	103.0					10.0
12.0	90.6	89.5	88.8	88.2					12.0
15.0	60.8	59.9	59.3	58.8	60.3				15.0
20.0	37.7	36.9	36.4	36.0	37.2	38.1	38.8		20.0
25.0	26.1	25.4	24.9	24.6	25.7	26.5	27.1	27.6	25.0
30.0	19.2	18.5	18.1	17.8	18.8	19.6	20.2	20.6	30.0
35.0		13.9	13.5	13.2	14.2	15.0	15.5	16.0	35.0
40.0		10.6	10.2	10.0	10.9	11.6	12.2	12.6	40.0
45.0			7.8	7.5	8.5	9.2	9.7	10.1	45.0
50.0				5.6	6.6	7.2	7.8	8.2	50.0
55.0				4.1	5.0	5.7	6.2	6.6	55.0
60.0					3.8	4.4	5.0	5.4	60.0
65.0					2.7	3.4	3.9	4.3	65.0
70.0						2.5	3.0	3.4	70.0
75.0						1.7	2.3	2.7	75.0
80.0						1.1	1.6	2.0	80.0
85.0							1.0	1.4	85.0
90.0							NR	NR	90.0
95.0							NR	NR	95.0
100.0								NR	100.0
105.0								NR	105.0

NOTE: Capacities appearing above the bold line are based on structural strength; tipping should not be relied upon as a capacity limitation.
 Capacities appearing below the bold line are based on stability and do not exceed 75% of tipping.

LOAD CHARTS

360 DEGREE RATING - LOADS IN lb x 1000

AUXILIARY BOOM NOSE SHEAVE with TRACKS FULLY EXTENDED									
35,000 lb COUNTERWEIGHT									
RADIUS (ft)	MAIN BOOM LENGTH (ft)								RADIUS (ft)
	37.5	45.4	53.3	61.2	73.8	86.4	99.0	111.6	
10	11.0	11.0	11.0	11.0					10
12	11.0	11.0	11.0	11.0					12
15	11.0	11.0	11.0	11.0	11.0				15
20	11.0	11.0	11.0	11.0	11.0	11.0	11.0		20
25	11.0	11.0	11.0	11.0	11.0	11.0	11.0	11.0	25
30	11.0	11.0	11.0	11.0	11.0	11.0	11.0	11.0	30
35		11.0	11.0	11.0	11.0	11.0	11.0	11.0	35
40		11.0	11.0	11.0	11.0	11.0	11.0	11.0	40
45			11.0	11.0	11.0	11.0	11.0	11.0	45
50				11.0	11.0	11.0	11.0	11.0	50
55				11.0	11.0	11.0	11.0	11.0	55
60					11.0	11.0	11.0	11.0	60
65					11.0	11.0	11.0	11.0	65
70						10.6	11.0	11.0	70
75						9.1	9.7	9.7	75
80						7.9	8.4	8.5	80
85							7.4	7.4	85
90							6.4	6.5	90
95							5.6	5.7	95
100								4.9	100
105								4.3	105

NOTE: Capacities appearing above the bold line are based on structural strength; tipping should not be relied upon as a capacity limitation. Capacities appearing below the bold line are based on stability and do not exceed 75% of tipping.

LOAD CHARTS

360 DEGREE RATING - LOADS IN lb x 1000

AUXILIARY BOOM NOSE SHEAVE with TRACKS RETRACTED									
17,500 lb COUNTERWEIGHT									
RADIUS (ft)	MAIN BOOM LENGTH (ft)								RADIUS (ft)
	37.5	45.4	53.3	61.2	73.8	86.4	99.0	111.6	
10	11.0	11.0	11.0	11.0					10
12	11.0	11.0	11.0	11.0					12
15	11.0	11.0	11.0	11.0	11.0				15
20	11.0	11.0	11.0	11.0	11.0	11.0	11.0		20
25	11.0	11.0	11.0	11.0	11.0	11.0	11.0	11.0	25
30	11.0	11.0	11.0	11.0	11.0	11.0	11.0	11.0	30
35		11.0	11.0	11.0	11.0	11.0	11.0	11.0	35
40		10.4	10.0	9.8	10.7	11.0	11.0	11.0	40
45			7.6	7.3	8.3	9.0	9.5	9.9	45
50				5.4	6.4	7.0	7.6	8.0	50
55				3.9	4.8	5.5	6.0	6.4	55
60					3.6	4.2	4.8	5.2	60
65					2.5	3.2	3.7	4.1	65
70						2.3	2.8	3.2	70
75						1.5	2.1	2.5	75
80						0.9	1.4	1.8	80
85							0.8	1.2	85
90							NR	NR	90
95							NR	NR	95
100								NR	100
105								NR	105

NOTE: Capacities appearing above the bold line are based on structural strength; tipping should not be relied upon as a capacity limitation.
 Capacities appearing below the bold line are based on stability and do not exceed 75% of tipping.

LOAD CHARTS

360 DEGREE RATING - LOADS IN lb x 1000

30' EXTENSION with TRACKS FULLY EXTENDED				
35,000 lb COUNTERWEIGHT		17,500 lb COUNTERWEIGHT		
Boom Angle	All Boom Lengths	Total Boom Length		Boom Angle
		67.5' to 129'	> 129'	
78°	18.0	18.0	18.0	78°
75°	13.6	13.6	13.6	75°
72°	11.5	11.5	11.5	72°
70°	10.1	10.1	10.1	70°
68°	8.9	8.9	8.9	68°
65°	8.0	8.0	8.0	65°
62°	7.2	7.2	7.2	62°
60°	6.7	6.7	6.7	60°
58°	6.1	6.1	6.1	58°
55°	5.8	5.8	5.8	55°
52°	5.3	5.3	5.3	52°
50°	5.1	5.1	4.8	50°
48°	4.9	4.9	4.2	48°
45°	4.6	4.6	3.5	45°

30' EXTENSION + 20' JIB with TRACKS FULLY EXTENDED				
35,000 lb or 17,500 lb COUNTERWEIGHT				
20' JIB				
Boom Angle	Jib Offset Angles			Boom Angle
	0°	15°	30°	
78°	6.6	4.0	2.2	78°
75°	6.3	4.0	2.1	75°
72°	5.6	3.5	2.0	72°
70°	5.1	3.2	1.9	70°
68°	4.6	3.0	1.8	68°
65°	4.2	2.8	1.8	65°
62°	3.9	2.6	1.7	62°
60°	3.5	2.4	1.7	60°
58°	3.2	1.9	1.4	58°
55°	2.6	1.3	1.0	55°
52°	2.0	0.6	0.4	52°
50°	1.5	0.3	0.2	50°

NOTE: Capacities appearing above the bold line are based on structural strength; tipping should not be relied upon as a capacity limitation.
Capacities appearing below the bold line are based on stability and do not exceed 75% of tipping.

LOAD CHARTS

750 WORK PLATFORM
Installed on MANTIS MODEL 15010
as originally manufactured and equipped by Tadano Mantis Corporation

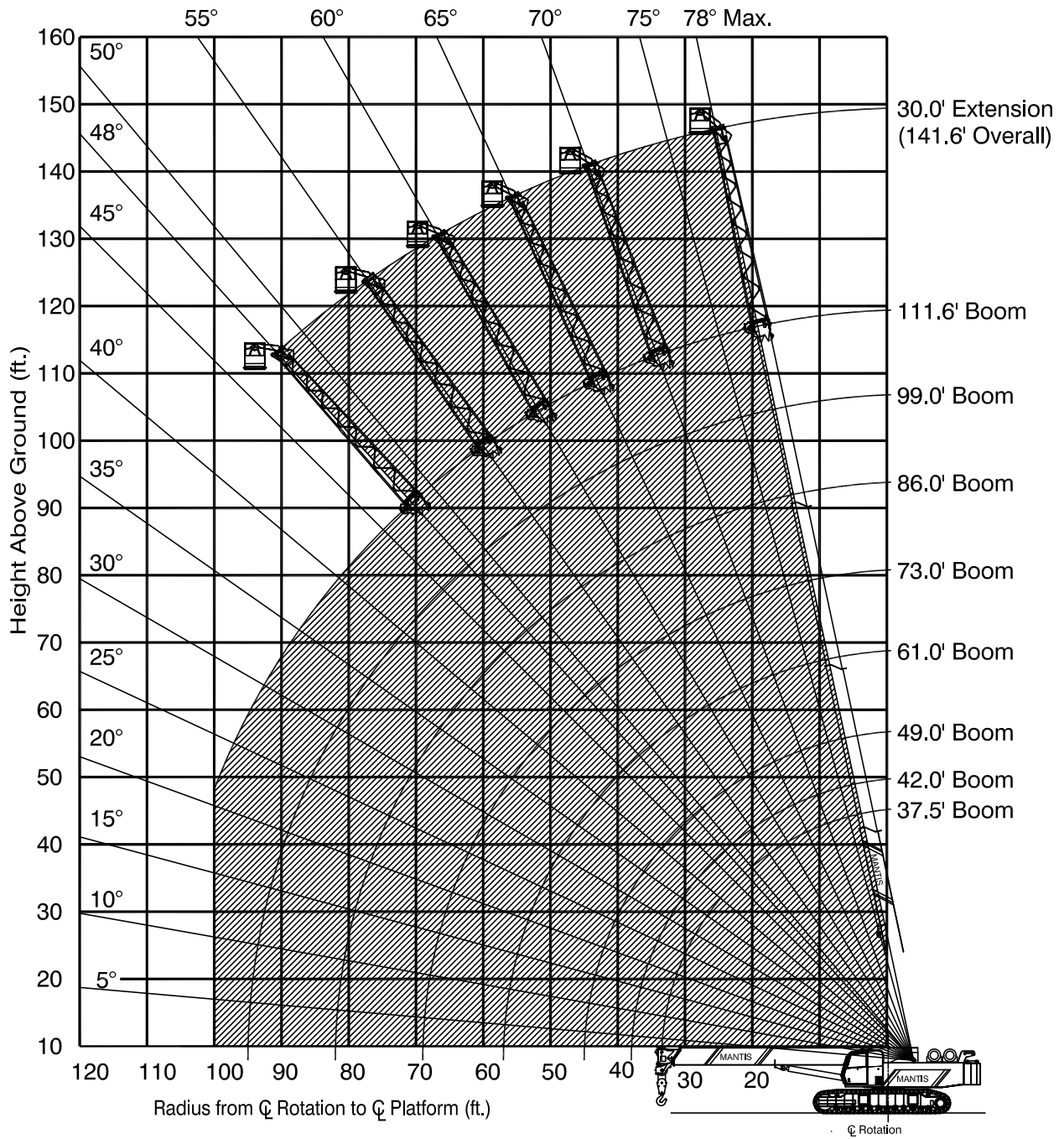

Limits of operation:

Maximum load capacity = 750 lb (340 kg)

Maximum radius when mounted on main boom = 100 ft (30.4 m)

Minimum boom angle when mounted on 30 ft (9.1 m) extension = 48°

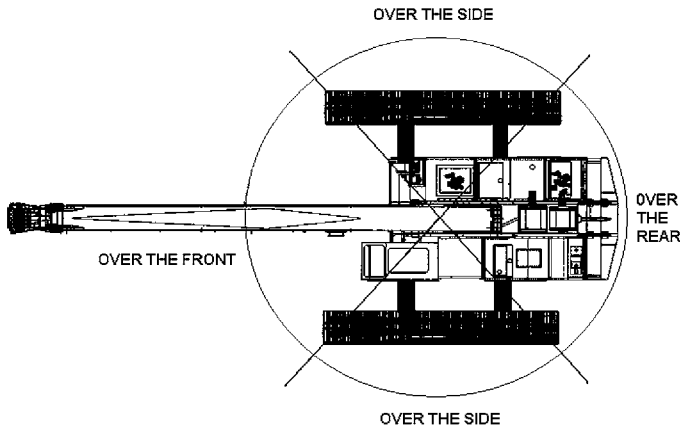

TADANO MANTIS 15010				
WIRE ROPE LINE PULL CAPACITIES				
PARTS OF LINE	MAIN WINCH	AUX WINCH	PARTS OF LINE	MAIN WINCH
1	16,800 lb (74.7 kN)	16,800 lb (74.7 kN)	6	95,712 lb (425.8 kN)
2	32,858 lb (146.1 kN)	32,858 lb (146.1 kN)	7	110,850 lb (493.1 kN)
3	48,924 lb (217.6 kN)	N/A	8	125,763 lb (559.4 kN)
4	64,753 lb (288.0 kN)	N/A	9	140,456 lb (624.7 kN)
5	80,348 lb (357.4 kN)	N/A	10	154,932 lb (689.1 kN)

3/4 inch (19 mm) diameter wire rope, 6x37 Class, EIP, IWRC

PLEASE READ, UNDERSTAND, AND FOLLOW THE MANUALS FURNISHED WITH THE CRANE (OPERATORS AND SAFETY) AS WELL AS THE CAPACITY LIMITATIONS AND GENERAL CONDITIONS LISTED BELOW PRIOR TO OPERATION OF THE CRANE. FAILURE TO DO SO MAY RESULT IN AN ACCIDENT.

This **MANTIS CRANE** as manufactured by Tadano Mantis Corporation meets the requirements of **ASME B30.5**. Structure and stability have been tested in accordance with **SAE J1063** and **SAE J765**, respectively. Lifting capacities as determined by boom length, angle or radius, apply only to machines as originally equipped by manufacturer and in a properly maintained condition. Capacities given are maximum covered by the manufacturer's warranty and are based on a freely suspended load with **NO** allowance for factors as out-of-level operation, supporting surface conditions, hazardous surroundings, experience of personnel, etc. The operator shall establish practical working loads based on prevailing operating conditions, such as, but not limited to the above.

When making lifts where capacities may be within a zone limited by structural strength, the operator shall determine that the weight of the load is known within plus or minus (+/-) ten percent (10%) before making lift. **DO NOT** lift load or extend boom without counterweight in place. Deductions from rated capacities must be made for the weight of the hook block, hook/ball, slings, spreader bar, or other suspended equipment.

Side pull on boom is extremely dangerous and must be avoided.

DO NOT exceed manufacturer's maximum specified reeving.

DO NOT use this chart if wind speed exceeds 20 mph. Consult the manufacturer for specialized load ratings.

Load radius is defined as the horizontal distance from the axis of rotation (with no load) to the center of the lifting device after load is applied. Boom angle is the included angle between the longitudinal axis of the boom base section and the Horizontal axis, after lifting load. The boom angle before lifting should be slightly greater than desired to account for boom deflection.

Boom angle/boom length relationships given are an approximation of the resulted load radius, which should be an accurate measurement. Boom height dimensions are measured from ground to center of lower boom head sheave.

It is permissible to attempt to telescope boom with a load within the limits of rated capacities. However, boom angle system hydraulic pressure, and/or boom lubrication may affect operation.

It is permissible to travel with loads within the rated capacity of the crane. Travel speeds should be greatly reduced to reflect terrain limitations and minimize dynamic loads applied to the crane structure.

TADANO MANTIS CORPORATION

1705 Columbia Avenue • Franklin, TN 37064 USA • Toll-Free: 1-800-272-3325 • Fax: 615-790-6803 • mantiscranes.com