

# HITACHI ZAXIS180W

engine rated power  
**90.2 kW / 121 HP**

operating weight  
**17 100 - 19 300 kg**

bucket capacity  
**0.51 - 1.20 m<sup>3</sup>**

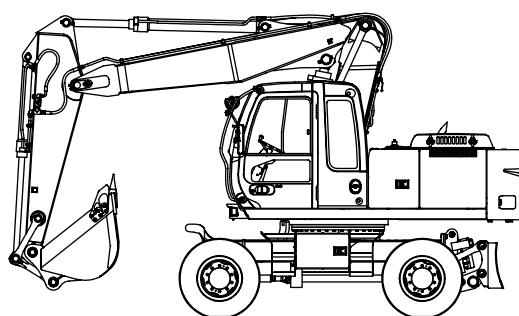

# HITACHI

## Engine

|                     |  |
|---------------------|--|
| Model               | Isuzu 4BG1XABFA  |
| Type                | 4-cycle water-cooled direct injection                                  |
| Aspiration          | Turbocharged intercooled   |
| No. of cylinders    | 4  |
| Rated power         |  |
| Traveling           |  |
| DIN 6271, net       | 90.2 kW (123 PS, 121 HP) at 2 200 min <sup>-1</sup> (rpm)              |
| SAE J1349, net      | 90.2 kW (123 PS, 121 HP) at 2 200 min <sup>-1</sup> (rpm)              |
| ISO 9249, net       | 90.2 kW (123 PS, 121 HP) at 2 200 min <sup>-1</sup> (rpm)              |
| ECE-R24             | 90.2 kW (123 PS, 121 HP) at 2 200 min <sup>-1</sup> (rpm)              |
| Digging             |  |
| DIN 6271, net       | H/P mode: 90.2 kW (123 PS, 121 HP)<br>at 2 200 min <sup>-1</sup> (rpm) |
|                     | P mode: 87.4 kW (119 PS, 117 HP)<br>at 2 000 min <sup>-1</sup> (rpm)   |
| SAE J1349, net      | H/P mode: 90.2 kW (123 PS, 121 HP)<br>at 2 200 min <sup>-1</sup> (rpm) |
|                     | P mode: 87.4 kW (119 PS, 117 HP)<br>at 2 000 min <sup>-1</sup> (rpm)   |
| ISO 9249, net       | H/P mode: 90.2 kW (123 PS, 121 HP)<br>at 2 200 min <sup>-1</sup> (rpm) |
|                     | P mode: 87.4 kW (119 PS, 117 HP)<br>at 2 000 min <sup>-1</sup> (rpm)   |
| Maximum torque      | 447 Nm at 1 800 min <sup>-1</sup> (rpm)                                |
| Piston Displacement | 4.329 l  |
| Bore and stroke     | 105 mm x 125 mm  |
| Batteries           | 2 x 12 V / 55 Ah   |
| Governor            | Mechanical speed control with stepping motor                           |

## Hydraulic system

- Work mode selector  
Digging mode / Attachment mode
- Engine speed sensing system

|                  |  |
|------------------|--|
| Main pumps       | 2 variable displacement axial piston pumps |
| Maximum oil flow | 2 x 200 l/min                              |
| Pilot pump       | 1 gear pump                                |
| Maximum oil flow | 26.6 l/min                                 |
| Steering pump    | 1 gear pump                                |
| Maximum oil flow | 26.6 l/min                                 |

### HYDRAULIC MOTORS

|        |  |
|--------|--|
| Travel | 1 variable displacement axial piston motor |
| Swing  | 1 axial piston motor                       |

### RELIEF VALVE SETTINGS

|                   |  |
|-------------------|--|
| Implement circuit | 34.3 MPa (350 kgf/cm <sup>2</sup> , 4 980 psi) |
| Swing circuit     | 33.3 MPa (340 kgf/cm <sup>2</sup> , 4 830 psi) |
| Travel circuit    | 34.3 MPa (350 kgf/cm <sup>2</sup> , 4 980 psi) |
| Pilot circuit     | 3.9 MPa (40 kgf/cm <sup>2</sup> , 570 psi)     |

### HYDRAULIC CYLINDERS

High-strength piston rods and tubes. Cylinder cushion mechanisms provided in boom and arm cylinders to absorb shock at stroke ends.

### DIMENSIONS

|                            | Qty. | Bore   | Rod diameter |
|----------------------------|------|--------|--------------|
| Boom (2-Piece boom)        | 2    | 110 mm | 80 mm        |
| Positioning (2-Piece boom) | 1    | 170 mm | 120 mm       |
| Boom (Monoblock boom)      | 2    | 110 mm | 80 mm        |
| Arm                        | 1    | 120 mm | 90 mm        |
| Bucket                     | 1    | 105 mm | 75 mm        |

### HYDRAULIC FILTERS

Hydraulic circuits use high-quality hydraulic filters. A suction filter is incorporated in the suction line, and full-flow filters in the return line and swing/travel motor drain lines.

## Controls

Pilot controls. Hitachi's original shockless valve and quick warm-up system built in the pilot circuit. Hydraulic warm-up control system for engine and hydraulic oil.

|                              |   |
|------------------------------|---|
| Implement levers             | 2 |
| Travel pedal                 | 1 |
| Outrigger and/or blade lever | 1 |
| Positioning and/or Att Pedal | 1 |

## Upperstructure

### REVOLVING FRAME

Welded sturdy box construction, using heavy-gauge steel plates for ruggedness. Reinforced frame for resistance to deformation.

### SWING MECHANISM

Axial piston motor with planetary reduction gear is bathed in oil. Swing circle is single-row, shear-type ball bearing with induction-hardened internal gear. Internal gear and pinion gear are immersed in lubricant.

Swing parking brake is spring-set/hydraulic-released disc type.

Swing speed 12.8 min<sup>-1</sup> (rpm)

### OPERATOR'S CAB

Independent spacious cab, 1 005 mm wide by 1 675 mm high, conforming to ISO standards. Reinforced glass windows on 4 sides for visibility. Front windows (upper and lower) can be opened. Reclining seat with armrests; adjustable with or without control levers.

## Undercarriage

Wheeled type undercarriage. The frame is of welded, stress-relieved structure.

Drive system: 2 gear power shift transmission and variable displacement axial piston type travel motor.

Travel speed (forward and reverse)

Creep speed range 0 to 2.6 km/h

Low speed range 0 to 7.2 km/h

High speed range 0 to 30.0 km/h

Gradeability 33 degree (64%)

Minimum turning radius 6 550 mm

Axle:

All-wheel drive.

The front axle can be locked hydraulically in any position.

Oscillating front axle left: ± 6°

right: ± 6°

Brakes system:

Maintenance free wet-disc brakes on front axle and rear axle are standard.

Fully hydraulic service brake system.

## Operating weight

### ZAXIS180W WITH MONOBLOCK BOOM:

Equipped with monoblock boom, 2.70 m arm and 0.7 m<sup>3</sup> (PCSA heaped) bucket.

| Stabilization            | Operating weight |             |
|--------------------------|------------------|-------------|
|                          | Short chassis    | STD chassis |
| Rear Blade               | 17 100 kg        | 17 400 kg   |
| Rear Outrigger           | 17 400 kg        | 17 700 kg   |
| Front and Rear Outrigger | -                | 18 800 kg   |
| Outrigger and Blade      | -                | 18 500 kg   |

### ZAXIS180W WITH 2-PIECE BOOM:

Equipped with 2-piece boom, 2.25 m arm 0.7 m<sup>3</sup> (PCSA heaped) and bucket.

| Stabilization            | Operating weight |             |
|--------------------------|------------------|-------------|
|                          | Short chassis    | STD chassis |
| Rear Blade               | 17 600 kg        | 17 900 kg   |
| Rear Outrigger           | 17 900 kg        | 18 200 kg   |
| Front and Rear Outrigger | -                | 19 300 kg   |
| Outrigger and Blade      | -                | 19 000 kg   |

## Service refill capacities

|                         |         |
|-------------------------|---------|
| Fuel tank               | 280 l   |
| Engine coolant          | 19.2 l  |
| Engine oil              | 15.8 l  |
| Swing mechanism         | 6.2 l   |
| Transmission            | 2.9 l   |
| Front differential gear | 8.5 l   |
| Rear differential gear  | 11 l    |
| Hub reduction gear      |         |
| Front axle              | 2 x 2 l |
| Rear axle               | 2 x 2 l |
| Hydraulic system        | 270 l   |
| Hydraulic tank          | 100 l   |

## Backhoe attachments

Booms and arms are of welded, box-section design.

Monoblock and 2-piece booms are available.

2.25 m, 2.70 m and 3.20 m arms are available.

Bucket is of all-welded, high-strength steel structure.

### BUCKETS

| Capacity            |                      | Width             |                      | Weight | Recommendation ZAXIS180W |            |            |
|---------------------|----------------------|-------------------|----------------------|--------|--------------------------|------------|------------|
| SAE (PCSA) heaped   | CECE heaped          | With side cutters | Without side cutters |        | 2.25 m arm               | 2.70 m arm | 3.20 m arm |
| 0.51 m <sup>3</sup> | 0.45 m <sup>3</sup>  | 720 mm            | 850 mm               | 530 kg | ⊙                        | ⊙          | ⊙          |
| 0.70 m <sup>3</sup> | 0.60 m <sup>3</sup>  | 900 mm            | 1 010 mm             | 610 kg | ⊙                        | ⊙          | ⊙          |
| 0.80 m <sup>3</sup> | 0.70 m <sup>3</sup>  | 1 030 mm          | 1 140 mm             | 670 kg | ⊙                        | ○          | □          |
| 0.91 m <sup>3</sup> | 0.80 m <sup>3</sup>  | 1 150 mm          | 1 280 mm             | 720 kg | ○                        | □          | -          |
| 1.10 m <sup>3</sup> | 0.90 m <sup>3</sup>  | 1 330 mm          | 1 460 mm             | 780 kg | ○                        | -          | -          |
| 1.20 m <sup>3</sup> | 1.000 m <sup>3</sup> | 1 450 mm          | -                    | 690 kg | □                        | -          | -          |

⊙ Suitable for materials with density of 1 800 kg/m<sup>3</sup> or less

○ Suitable for materials with density of 1 600 kg/m<sup>3</sup> or less

□ Suitable for materials with density of 1 100 kg/m<sup>3</sup> or less

# SPECIFICATIONS

## Dimensions

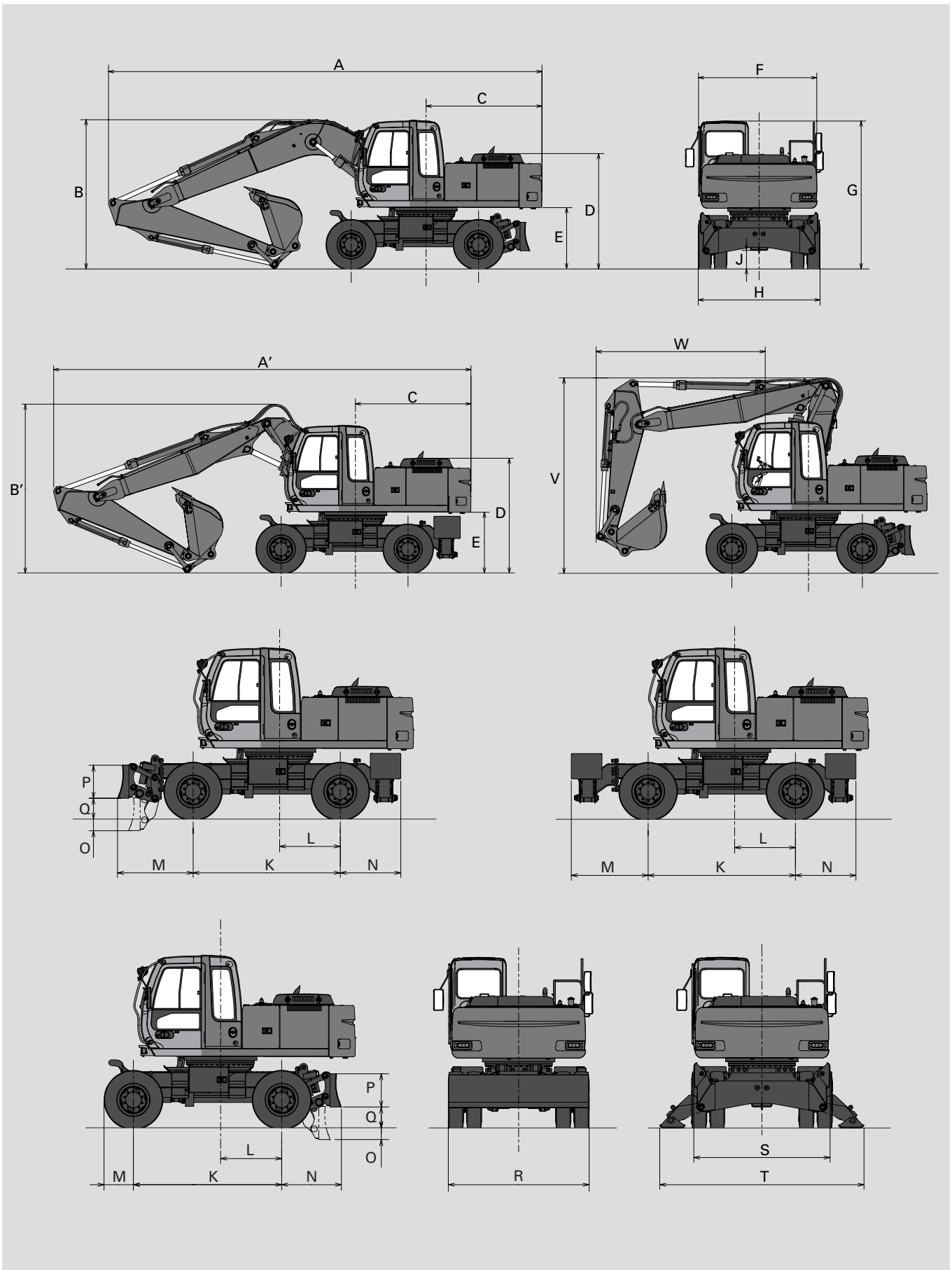

## Dimensions

Unit: mm

|  | Short Chassis |          | STD Chassis |          |                      |                       |
|--|---------------|----------|-------------|----------|----------------------|-----------------------|
|  | Rear BL       | Rear O/R | Rear BL     | Rear O/R | Front BL<br>Rear O/R | Front and<br>Rear O/R |
| A Overall length (with monoblock boom) |               |          |             |          |                      |                       |
| 2.25 m arm                             | 9 000         | 9 000    | 9 000       | 9 000    | 9 000                | 9 000                 |
| 2.70 m arm                             | 8 880         | 8 880    | 9 010       | 9 010    | 9 370                | 9 370                 |
| 3.20 m arm                             | 8 880         | 8 880    | 9 010       | 9 010    | 9 370                | 9 370                 |
| A' Overall length (with 2-piece boom)  |               |          |             |          |                      |                       |
| 2.25 m arm                             | 8 740         | 8 740    | 8 740       | 8 740    | 8 740                | 8 740                 |
| 2.70 m arm                             | 8 720         | 8 720    | 8 850       | 8 850    | 9 210                | 9 210                 |
| 3.20 m arm                             | 8 690         | 8 690    | 8 820       | 8 820    | 9 180                | 9 180                 |
| B Overall height (with monoblock boom) |               |          |             |          |                      |                       |
| 2.25 m arm                             |               |          |             | 3 130    |                      |                       |
| 2.70 m arm                             |               |          |             | 3 100    |                      |                       |
| 3.20 m arm                             |               |          |             | 3 410    |                      |                       |
| B' Overall height (with 2-piece boom)  |               |          |             |          |                      |                       |
| 2.25 m arm                             |               |          |             | 3 520    |                      |                       |
| 2.70 m arm                             |               |          |             | 3 520    |                      |                       |
| 3.20 m arm                             |               |          |             | 3 710    |                      |                       |
| C Rear-end swing radius                |               |          |             | 2 440    |                      |                       |
| D Engine cover height                  |               |          |             | 2 400    |                      |                       |
| E Counterweight clearance              |               |          |             | 1 270    |                      |                       |
| F Overall width of the upperstructure  |               |          |             | 2 465    |                      |                       |
| G Overall height of cabin              |               |          |             | 3 080    |                      |                       |
| H Overall width of tires               |               |          |             | 2 530    |                      |                       |
| J Minimum ground clearance             |               |          |             | 360      |                      |                       |
| K Wheel base                           |               |          |             | 2 650    |                      |                       |
| L Swing-center to rear axle            |               |          |             | 1 100    |                      |                       |
| M Front overhang                       | 530           | 530      | 1 020       | 1 020    | 1 360                | 1 380                 |
| N Rear overhang                        | 1 070         | 1 090    | 1 070       | 1 090    | 1 090                | 1 090                 |
| O Maximum blade lower                  | 220           | -        | 220         | -        | 220                  | -                     |
| P Height of blade                      | 590           | -        | 590         | -        | 590                  | -                     |
| Q Maximum blade raise                  | 370           | -        | 370         | -        | 370                  | -                     |
| R Overall width of blade               | 2 530         | -        | 2 530       | -        | 2 530                | -                     |
| S Overall width of O/R retract         | -             | 2 470    | -           | 2 470    | 2 470                | 2 470                 |
| T Overall width of O/R extend          | -             | 3 700    | -           | 3 700    | 3 700                | 3 700                 |
| V Overall height of boom (traveling)   |               |          |             |          |                      |                       |
| *2.25 m arm                            |               |          |             | 4 000    |                      |                       |
| 2.70 m arm                             |               |          |             | 3 810    |                      |                       |
| 3.20 m arm                             |               |          |             | 4 000    |                      |                       |
| W Front overhang (traveling)           |               |          |             |          |                      |                       |
| *2.25 m arm                            |               |          |             | 3 470    |                      |                       |
| 2.70 m arm                             |               |          |             | 5 310    |                      |                       |
| 3.20 m arm                             |               |          |             | 5 110    |                      |                       |

Transportation dimensions are A (A'), B (B'), H (without blade) or A (A'), B (B'), R (with blade).

\* Certified by the German Automobile Inspection.

# SPECIFICATIONS

## Working ranges

### ZAXIS180W WITH MONOBLOCK BOOM

Unit: mm

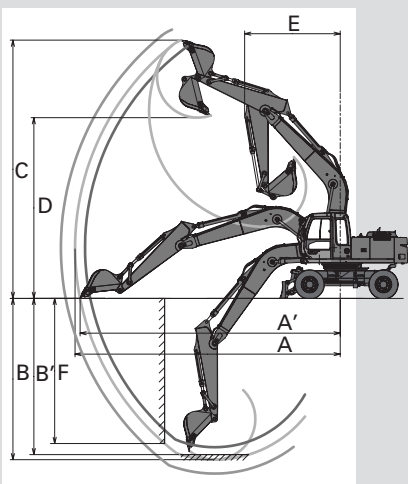

| Arm length                        | 2.25 m                 | 2.70 m                 | 3.20 m                 |
|-----------------------------------|------------------------|------------------------|------------------------|
| A Max. digging reach              | 9 160                  | 9 520                  | 10 030                 |
| A' Max. digging reach (on ground) | 8 970                  | 9 340                  | 9 860                  |
| B Max. digging depth              | 5 340                  | 5 790                  | 6 290                  |
| B' Max. digging depth (8' level)  | 5 140                  | 5 610                  | 6 130                  |
| C Max. cutting height             | 9 180                  | 9 270                  | 9 650                  |
| D Max. dumping height             | 6 380                  | 6 490                  | 6 830                  |
| E Min. swing radius               | 3 460                  | 3 430                  | 3 400                  |
| F Max. vertical wall              | 4 770                  | 5 210                  | 5 710                  |
| Bucket digging force ISO          | 116 kN<br>(11 800 kgf) | 116 kN<br>(11 800 kgf) | 116 kN<br>(11 800 kgf) |
| Bucket digging force SAE : PCSA   | 102 kN<br>(10 400 kgf) | 102 kN<br>(10 400 kgf) | 102 kN<br>(10 400 kgf) |
| Arm digging force ISO             | 99 kN<br>(10 100 kgf)  | 86 kN<br>(8 800 kgf)   | 76 kN<br>(7 800 kgf)   |
| Arm digging force SAE : PCSA      | 95 kN<br>(9 700 kgf)   | 83 kN<br>(8 500 kgf)   | 74 kN<br>(7 600 kgf)   |

### ZAXIS180W WITH 2-PIECE BOOM

Unit: mm

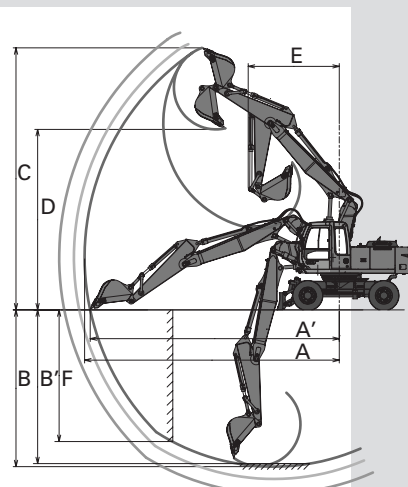

| Arm length                        | 2.25 m                 | 2.70 m                 | 3.20 m                 |
|-----------------------------------|------------------------|------------------------|------------------------|
| A Max. digging reach              | 8 870                  | 9 240                  | 9 750                  |
| A' Max. digging reach (on ground) | 8 670                  | 9 050                  | 9 570                  |
| B Max. digging depth              | 5 450                  | 5 880                  | 6 390                  |
| B' Max. digging depth (8' level)  | 5 350                  | 5 790                  | 6 310                  |
| C Max. cutting height             | 9 120                  | 9 250                  | 9 640                  |
| D Max. dumping height             | 6 280                  | 6 420                  | 6 790                  |
| E Min. swing radius               | 3 170                  | 3 160                  | 3 170                  |
| F Max. vertical wall              | 4 580                  | 5 000                  | 5 570                  |
| Bucket digging force ISO          | 116 kN<br>(11 800 kgf) | 116 kN<br>(11 800 kgf) | 116 kN<br>(11 800 kgf) |
| Bucket digging force SAE : PCSA   | 102 kN<br>(10 400 kgf) | 102 kN<br>(10 400 kgf) | 102 kN<br>(10 400 kgf) |
| Arm digging force ISO             | 99 kN<br>(10 100 kgf)  | 86 kN<br>(8 800 kgf)   | 76 kN<br>(7 800 kgf)   |
| Arm digging force SAE : PCSA      | 95 kN<br>(9 700 kgf)   | 83 kN<br>(8 500 kgf)   | 74 kN<br>(7 600 kgf)   |

# LIFTING CAPACITIES

## Metric measure

### ZAXIS180W WITH MONOBLOCK BOOM, 2.70 M ARM, STD CHASSIS

- Notes:
1. Ratings are based on 10567.
  2. Lifting capacity of the ZAXIS series does not exceed 75% of tipping load with the machine on firm level ground, or 87% full hydraulic capacity.
  3. The load point is the center-line of the bucket pivot mounting pin on the arm.
  4. \*Indicates load limited by hydraulic capacity.
  5. 0 m = Ground.

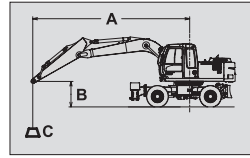

A: Load radius  
B: Load point height  
C: Lifting capacity



Rating over-side or 360 degrees



Rating over-front

Unit: 1 000 kg

|                  | Stabilization                       | Load radius |       |       |      |      |      |      |      |      |      | At max. reach |      | meter |
|------------------|-------------------------------------|-------------|-------|-------|------|------|------|------|------|------|------|---------------|------|-------|
|                  |                                     | 3 m         |       | 4 m   |      | 5 m  |      | 6 m  |      | 7 m  |      | meter         |      |       |
|                  |                                     |             |       |       |      |      |      |      |      |      |      |               |      |       |
| 6 m              | Rear blade up                       |             |       |       |      |      |      | *4.9 | 3.5  |      |      | 2.7           | 2.4  | 6.86  |
|                  | Rear blade down                     |             |       |       |      |      |      | *4.9 | 4.2  |      |      | *3.4          | 2.8  |       |
|                  | Rear outrigger down                 |             |       |       |      |      |      | *4.9 | 4.2  |      |      | *3.4          | 3.3  |       |
|                  | Front outrigger and rear blade down |             |       |       |      |      |      | *4.9 | *4.9 |      |      | *3.4          | *3.4 |       |
|                  | Front blade and rear outrigger down |             |       |       |      |      |      | *4.9 | *4.9 |      |      | *3.4          | *3.4 |       |
| 4 outrigger down |                                     |             |       |       |      |      | *4.9 | *4.9 |      |      | *3.4 | *3.4          |      |       |
| 5 m              | Rear blade up                       |             |       |       |      | 4.5  | 4.0  | 3.4  | 3.0  | 2.6  | 2.3  | 2.4           | 2.1  | 7.39  |
|                  | Rear blade down                     |             |       |       |      | *5.8 | 4.5  | *5.3 | 3.4  | *4.5 | 2.6  | *3.4          | 2.4  |       |
|                  | Rear outrigger down                 |             |       |       |      | *5.8 | 5.5  | *5.3 | 4.1  | *4.5 | 3.2  | *3.4          | 2.9  |       |
|                  | Front outrigger and rear blade down |             |       |       |      | *5.8 | *5.8 | *5.3 | 4.9  | *4.5 | 3.8  | *3.4          | *3.4 |       |
|                  | Front blade and rear outrigger down |             |       |       |      | *5.8 | *5.8 | *5.3 | 5.1  | *4.5 | 4.0  | *3.4          | *3.4 |       |
| 4 outrigger down |                                     |             |       |       | *5.8 | *5.8 | *5.3 | *5.3 | *4.5 | *4.5 | *3.4 | *3.4          |      |       |
| 4 m              | Rear blade up                       | 9.6         | 8.2   | 6.1   | 5.3  | 4.4  | 3.8  | 3.3  | 2.9  | 2.6  | 2.3  | 2.2           | 1.9  | 7.75  |
|                  | Rear blade down                     | *10.0       | 9.6   | *7.7  | 6.1  | *6.4 | 4.4  | *5.6 | 3.3  | *5.1 | 2.6  | *3.4          | 2.2  |       |
|                  | Rear outrigger down                 | *10.0       | *10.0 | *7.7  | 7.5  | *6.4 | 5.3  | *5.6 | 4.0  | 4.9  | 3.1  | *3.4          | 2.6  |       |
|                  | Front outrigger and rear blade down | *10.0       | *10.0 | *7.7  | *7.7 | *6.4 | 6.3  | *5.6 | 4.8  | *5.1 | 3.7  | *3.4          | 3.2  |       |
|                  | Front blade and rear outrigger down | *10.0       | *10.0 | *7.7  | *7.7 | *6.4 | *6.4 | *5.6 | 5.0  | *5.1 | 3.9  | *3.4          | 3.3  |       |
| 4 outrigger down | *10.0                               | *10.0       | *7.7  | *7.7  | *6.4 | *6.4 | *5.6 | *5.6 | *5.1 | 4.5  | *3.4 | *3.4          |      |       |
| 3 m              | Rear blade up                       |             |       | 5.7   | 4.9  | 4.1  | 3.6  | 3.2  | 2.8  | 2.5  | 2.2  | 2.0           | 1.8  | 7.97  |
|                  | Rear blade down                     |             |       | *8.9  | 5.7  | *7.1 | 4.1  | *6.0 | 3.2  | *5.3 | 2.5  | *3.5          | 2.0  |       |
|                  | Rear outrigger down                 |             |       | *8.9  | 7.0  | *7.1 | 5.0  | *6.0 | 3.8  | 4.8  | 3.0  | *3.5          | 2.5  |       |
|                  | Front outrigger and rear blade down |             |       | *8.9  | 8.6  | *7.1 | 6.1  | *6.0 | 4.6  | *5.3 | 3.7  | *3.5          | 3.0  |       |
|                  | Front blade and rear outrigger down |             |       | *8.9  | *8.9 | *7.1 | 6.4  | *6.0 | 4.9  | *5.3 | 3.9  | *3.5          | 3.2  |       |
| 4 outrigger down |                                     |             | *8.9  | *8.9  | *7.1 | *7.1 | *6.0 | 5.6  | *5.3 | 4.4  | *3.5 | *3.5          |      |       |
| 2 m              | Rear blade up                       |             |       | 5.3   | 4.6  | 3.9  | 3.4  | 3.0  | 2.6  | 2.4  | 2.1  | 2.0           | 1.7  | 8.06  |
|                  | Rear blade down                     |             |       | *9.9  | 5.3  | *7.7 | 3.9  | *6.4 | 3.0  | 5.4  | 2.4  | *3.7          | 2.0  |       |
|                  | Rear outrigger down                 |             |       | *9.9  | 6.6  | *7.7 | 4.8  | 6.0  | 3.7  | 4.7  | 3.0  | *3.7          | 2.4  |       |
|                  | Front outrigger and rear blade down |             |       | *9.9  | 8.2  | *7.7 | 5.9  | *6.4 | 4.5  | *5.5 | 3.6  | *3.7          | 2.9  |       |
|                  | Front blade and rear outrigger down |             |       | *9.9  | 8.7  | *7.7 | 6.2  | *6.4 | 4.7  | 5.3  | 3.8  | *3.7          | 3.1  |       |
| 4 outrigger down |                                     |             | *9.9  | *9.9  | *7.7 | 7.2  | *6.4 | 5.5  | 5.5  | 4.4  | *3.7 | 3.5           |      |       |
| 1 m              | Rear blade up                       |             |       | 5.1   | 4.3  | 3.7  | 3.2  | 2.9  | 2.5  | 2.4  | 2.0  | 1.9           | 1.7  | 8.02  |
|                  | Rear blade down                     |             |       | *10.3 | 5.1  | *8.0 | 3.8  | *6.6 | 2.9  | 5.3  | 2.4  | *3.9          | 1.9  |       |
|                  | Rear outrigger down                 |             |       | *10.3 | 6.4  | 7.9  | 4.6  | 5.9  | 3.6  | 4.7  | 2.9  | 3.8           | 2.4  |       |
|                  | Front outrigger and rear blade down |             |       | *10.3 | 7.9  | *8.0 | 5.7  | *6.6 | 4.4  | *5.6 | 3.5  | *3.9          | 2.9  |       |
|                  | Front blade and rear outrigger down |             |       | *10.3 | 8.5  | *8.0 | 6.0  | *6.6 | 4.6  | 5.2  | 3.7  | *3.9          | 3.0  |       |
| 4 outrigger down |                                     |             | *10.3 | 10.1  | *8.0 | 7.0  | *6.6 | 5.4  | 5.4  | 4.3  | *3.9 | 3.5           |      |       |
| 0 m              | Rear blade up                       | *4.7        | *4.7  | 4.9   | 4.2  | 3.6  | 3.1  | 2.8  | 2.5  | 2.3  | 2.0  | 2.0           | 1.7  | 7.85  |
|                  | Rear blade down                     | *4.7        | *4.7  | *10.2 | 4.9  | *8.1 | 3.6  | 6.6  | 2.8  | 5.2  | 2.3  | *4.3          | 2.0  |       |
|                  | Rear outrigger down                 | *4.7        | *4.7  | *10.2 | 6.2  | 7.7  | 4.5  | 5.8  | 3.5  | 4.6  | 2.8  | 3.9           | 2.4  |       |
|                  | Front outrigger and rear blade down | *4.7        | *4.7  | *10.2 | 7.8  | *8.1 | 5.6  | *6.7 | 4.3  | *5.6 | 3.5  | *4.3          | 2.9  |       |
|                  | Front blade and rear outrigger down | *4.7        | *4.7  | *10.2 | 8.3  | *8.1 | 5.9  | 6.5  | 4.5  | 5.1  | 3.6  | *4.3          | 3.1  |       |
| 4 outrigger down | *4.7                                | *4.7        | *10.2 | 9.9   | *8.1 | 6.9  | *6.7 | 5.3  | 5.3  | 4.2  | *4.3 | 3.6           |      |       |
| -1 m             | Rear blade up                       | *7.3        | 6.4   | 4.9   | 4.2  | 3.6  | 3.1  | 2.8  | 2.4  | 2.3  | 2.0  | 2.1           | 1.8  | 7.53  |
|                  | Rear blade down                     | *7.3        | *7.3  | *9.8  | 4.9  | *7.9 | 3.6  | *6.5 | 2.8  | 5.2  | 2.3  | 4.6           | 2.1  |       |
|                  | Rear outrigger down                 | *7.3        | *7.3  | *9.8  | 6.2  | 7.7  | 4.5  | 5.7  | 3.5  | 4.6  | 2.8  | 4.1           | 2.5  |       |
|                  | Front outrigger and rear blade down | *7.3        | *7.3  | *9.8  | 7.8  | *7.9 | 5.5  | *6.5 | 4.2  | *5.4 | 3.4  | *4.8          | 3.1  |       |
|                  | Front blade and rear outrigger down | *7.3        | *7.3  | *9.8  | 8.3  | *7.9 | 5.8  | 6.4  | 4.5  | 5.1  | 3.6  | 4.6           | 3.3  |       |
| 4 outrigger down | *7.3                                | *7.3        | *9.8  | *9.8  | *7.9 | 6.9  | *6.5 | 5.2  | 5.3  | 4.2  | 4.8  | 3.8           |      |       |
| -2 m             | Rear blade up                       | 7.8         | 6.5   | 4.9   | 4.2  | 3.6  | 3.1  | 2.8  | 2.4  | 2.3  | 2.0  | 2.3           | 2.0  | 7.07  |
|                  | Rear blade down                     | *10.3       | 7.8   | *8.9  | 4.9  | *7.3 | 3.6  | *6.0 | 2.8  | *4.8 | 2.3  | *4.8          | 2.3  |       |
|                  | Rear outrigger down                 | *10.3       | 10.1  | *8.9  | 6.2  | *7.3 | 4.5  | 5.7  | 3.5  | 4.6  | 2.8  | 4.5           | 2.8  |       |
|                  | Front outrigger and rear blade down | *10.3       | *10.3 | *8.9  | 7.8  | *7.3 | 5.5  | *6.0 | 4.2  | *4.8 | 3.4  | *4.8          | 3.4  |       |
|                  | Front blade and rear outrigger down | *10.3       | *10.3 | *8.9  | 8.3  | *7.3 | 5.8  | *6.0 | 4.5  | *4.8 | 3.6  | *4.8          | 3.6  |       |
| 4 outrigger down | *10.3                               | *10.3       | *8.9  | *8.9  | *7.3 | 6.8  | *6.0 | 5.2  | *4.8 | 4.2  | *4.8 | 4.1           |      |       |
| -3 m             | Rear blade up                       | 7.9         | 6.6   | 5.0   | 4.3  | 3.6  | 3.1  | 2.8  | 2.4  |      |      | 2.6           | 2.3  | 6.4   |
|                  | Rear blade down                     | *9.3        | 7.9   | *7.7  | 5.0  | *6.4 | 3.6  | *5.1 | 2.8  |      |      | *4.6          | 2.6  |       |
|                  | Rear outrigger down                 | *9.3        | *9.3  | *7.7  | 6.3  | *6.4 | 4.5  | *5.1 | 3.5  |      |      | *4.6          | 3.2  |       |
|                  | Front outrigger and rear blade down | *9.3        | *9.3  | *7.7  | *7.7 | *6.4 | 5.5  | *5.1 | 4.3  |      |      | *4.6          | 3.9  |       |
|                  | Front blade and rear outrigger down | *9.3        | *9.3  | *7.7  | *7.7 | *6.4 | 5.9  | *5.1 | 4.5  |      |      | *4.6          | 4.1  |       |
| 4 outrigger down | *9.3                                | *9.3        | *7.7  | *7.7  | *6.4 | *6.4 | *5.1 | *5.1 |      |      | *4.6 | *4.6          |      |       |

# LIFTING CAPACITIES

## Metric measure

### ZAXIS180W WITH 2-PIECE BOOM, 2.25 M ARM, STD CHASSIS

- Notes:
1. Ratings are based on 10567.
  2. Lifting capacity of the ZAXIS series does not exceed 75% of tipping load with the machine on firm level ground, or 87% full hydraulic capacity.
  3. The load point is the center-line of the bucket pivot mounting pin on the arm.
  4. \*Indicates load limited by hydraulic capacity.
  5. 0 m = Ground.

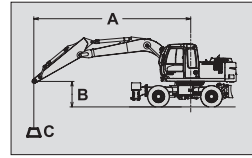

A: Load radius  
B: Load point height  
C: Lifting capacity



Rating over-side or 360 degrees



Rating over-front

Unit: 1 000 kg

|                                     | Stabilization                       | Load radius |       |       |       |      |      |      |      |      |      | At max. reach |      | meter |
|-------------------------------------|-------------------------------------|-------------|-------|-------|-------|------|------|------|------|------|------|---------------|------|-------|
|                                     |                                     | 3 m         |       | 4 m   |       | 5 m  |      | 6 m  |      | 7 m  |      | meter         |      |       |
|                                     |                                     |             |       |       |       |      |      |      |      |      |      |               |      |       |
| 6 m                                 | Rear blade up                       |             |       |       |       | *4.2 | *4.2 | 3.5  | 3.1  |      |      | 3.4           | 3.0  | 6.07  |
|                                     | Rear blade down                     |             |       |       |       | *4.2 | *4.2 | *4.5 | 3.5  |      |      | *4.4          | 3.4  |       |
|                                     | Rear outrigger down                 |             |       |       |       | *4.2 | *4.2 | *4.5 | 4.2  |      |      | *4.4          | 4.1  |       |
|                                     | Front outrigger and rear blade down |             |       |       |       | *4.2 | *4.2 | *4.5 | *4.5 |      |      | *4.4          | *4.4 |       |
|                                     | Front blade and rear outrigger down |             |       |       |       | *4.2 | *4.2 | *4.5 | *4.5 |      |      | *4.4          | *4.4 |       |
| 5 m                                 | 4 outrigger down                    |             |       |       |       | *4.2 | *4.2 | *4.5 | *4.5 |      |      | *4.4          | *4.4 |       |
|                                     | Rear blade up                       |             |       |       |       | *4.5 | 4.1  | 3.5  | 3.1  |      |      | 2.9           | 2.5  | 6.66  |
|                                     | Rear blade down                     |             |       |       |       | *4.5 | *4.5 | *4.5 | 3.5  |      |      | *4.2          | 2.9  |       |
|                                     | Rear outrigger down                 |             |       |       |       | *4.5 | *4.5 | *4.5 | 4.2  |      |      | *4.2          | 3.5  |       |
|                                     | Front outrigger and rear blade down |             |       |       |       | *4.5 | *4.5 | *4.5 | *4.5 |      |      | *4.2          | 4.2  |       |
| Front blade and rear outrigger down |                                     |             |       |       | *4.5  | *4.5 | *4.5 | *4.5 |      |      | *4.2 | *4.2          |      |       |
| 4 m                                 | 4 outrigger down                    |             |       |       |       | *4.5 | *4.5 | *4.5 | *4.5 |      |      | *4.2          | *4.2 |       |
|                                     | Rear blade up                       | *7.2        | *7.2  | *5.9  | 5.5   | 4.5  | 4.1  | 3.5  | 3.1  | 2.6  | 2.3  | 2.6           | 2.2  | 7.07  |
|                                     | Rear blade down                     | *7.2        | *7.2  | *5.9  | *5.9  | *5.2 | 4.6  | *4.8 | 3.6  | *4.7 | 2.6  | *4.2          | 2.6  |       |
|                                     | Rear outrigger down                 | *7.2        | *7.2  | *5.9  | *5.9  | *5.2 | *5.2 | *4.8 | *4.2 | *4.7 | 3.2  | *4.2          | 3.1  |       |
|                                     | Front outrigger and rear blade down | *7.2        | *7.2  | *5.9  | *5.9  | *5.2 | *5.2 | *4.8 | *4.8 | *4.7 | 3.8  | *4.2          | 3.7  |       |
| Front blade and rear outrigger down | *7.2                                | *7.2        | *5.9  | *5.9  | *5.2  | *5.2 | *4.8 | *4.8 | *4.7 | 4.0  | *4.2 | 3.9           |      |       |
| 3 m                                 | 4 outrigger down                    | *7.2        | *7.2  | *5.9  | *5.9  | *5.2 | *5.2 | *4.8 | *4.8 | *4.7 | 4.6  | *4.2          | *4.2 |       |
|                                     | Rear blade up                       | *7.6        | *7.6  | 6.1   | 5.4   | 4.5  | 4.0  | 3.5  | 3.1  | 2.6  | 2.3  | 2.4           | 2.1  | 7.31  |
|                                     | Rear blade down                     | *7.6        | *7.6  | *7.4  | 6.1   | *5.9 | 4.5  | *5.2 | 3.5  | *4.9 | 2.6  | *4.3          | 2.4  |       |
|                                     | Rear outrigger down                 | *7.6        | *7.6  | *7.4  | 7.2   | *5.9 | 5.3  | *5.2 | 4.1  | *4.9 | 3.1  | *4.3          | 2.9  |       |
|                                     | Front outrigger and rear blade down | *7.6        | *7.6  | *7.4  | *7.4  | *5.9 | *5.9 | *5.2 | 4.8  | *4.9 | 3.8  | *4.3          | 3.5  |       |
| Front blade and rear outrigger down | *7.6                                | *7.6        | *7.4  | *7.4  | *5.9  | *5.9 | *5.2 | 5.0  | *4.9 | 4.0  | *4.3 | 3.7           |      |       |
| 2 m                                 | 4 outrigger down                    | *7.6        | *7.6  | *7.4  | *7.4  | *5.9 | *5.9 | *5.2 | *5.2 | *4.9 | 4.6  | *4.3          | 4.2  |       |
|                                     | Rear blade up                       | 9.1         | 8.0   | 6.0   | 5.3   | *4.5 | 4.0  | 3.5  | 3.0  | 2.5  | 2.2  | 2.3           | 2.0  | 7.40  |
|                                     | Rear blade down                     | *9.7        | 9.1   | *8.8  | 6.0   | *6.8 | 4.5  | *5.7 | 3.5  | *5.1 | 2.6  | *4.5          | 2.3  |       |
|                                     | Rear outrigger down                 | *9.7        | *9.7  | *8.8  | 7.2   | *6.8 | 5.3  | *5.7 | 4.2  | 4.9  | 3.1  | 4.4           | 2.8  |       |
|                                     | Front outrigger and rear blade down | *9.7        | *9.7  | *8.8  | 8.5   | *6.8 | 6.2  | *5.7 | 4.8  | *5.1 | 3.7  | *4.5          | 3.4  |       |
| Front blade and rear outrigger down | *9.7                                | *9.7        | *8.8  | *8.8  | *6.8  | *6.4 | *5.7 | 5.0  | *5.1 | 3.9  | *4.5 | 3.5           |      |       |
| 1 m                                 | 4 outrigger down                    | *9.7        | *9.7  | *8.8  | *8.8  | *6.8 | *6.8 | *5.7 | 5.6  | *5.1 | 4.5  | *4.5          | 4.1  |       |
|                                     | Rear blade up                       | *9.2        | 8.0   | *6.0  | 5.3   | 4.5  | 4.0  | 3.3  | 2.9  | 2.5  | 2.2  | 2.2           | 2.0  | 7.36  |
|                                     | Rear blade down                     | *11.4       | *9.2  | *9.7  | *6.0  | *7.4 | 4.5  | *6.2 | 3.3  | *5.4 | 2.5  | *4.8          | 2.3  |       |
|                                     | Rear outrigger down                 | *11.4       | 11.2  | *9.7  | 7.2   | *7.4 | 5.3  | 6.1  | 4.0  | 4.9  | 3.0  | 4.4           | 2.8  |       |
|                                     | Front outrigger and rear blade down | *11.4       | *11.4 | *9.7  | 8.5   | *7.4 | 6.2  | *6.2 | 4.9  | *5.4 | 3.7  | *4.8          | 3.4  |       |
| Front blade and rear outrigger down | *11.4                               | *11.4       | *9.7  | 8.9   | *7.4  | 6.5  | *6.2 | *5.1 | *5.4 | 3.9  | *4.8 | 3.5           |      |       |
| 0 m                                 | 4 outrigger down                    | *11.4       | *11.4 | *9.7  | *9.7  | *7.4 | 7.3  | *6.2 | 5.7  | *5.4 | 4.5  | *4.8          | 4.1  |       |
|                                     | Rear blade up                       | 9.3         | 8.0   | 6.1   | 5.3   | 4.4  | 3.9  | 3.2  | 2.8  | 2.4  | 2.1  | 2.3           | 2.0  | 7.17  |
|                                     | Rear blade down                     | *13.1       | 9.3   | *10.2 | 6.1   | *7.9 | 4.4  | *6.5 | 3.2  | 5.4  | 2.4  | 5.2           | 2.3  |       |
|                                     | Rear outrigger down                 | *13.1       | 11.4  | *10.2 | 7.3   | *7.9 | 5.4  | *6.2 | 3.9  | 4.8  | 3.0  | 4.6           | 2.8  |       |
|                                     | Front outrigger and rear blade down | *13.1       | *13.1 | *10.2 | 8.6   | *7.9 | 6.3  | *6.5 | 4.7  | *5.6 | 3.6  | *5.3          | 3.4  |       |
| Front blade and rear outrigger down | *13.1                               | *13.1       | *10.2 | 9.0   | *7.9  | *6.5 | *6.5 | 5.0  | 5.3  | 3.8  | 5.1  | 3.6           |      |       |
| -1 m                                | 4 outrigger down                    | *13.1       | *13.1 | *10.2 | *10.2 | *7.9 | 7.3  | *6.5 | 5.7  | 5.5  | 4.4  | 5.3           | 4.2  |       |
|                                     | Rear blade up                       | 9.1         | 7.7   | 5.9   | 5.1   | 4.2  | 3.7  | 3.1  | 2.7  |      |      | 2.4           | 2.1  | 6.83  |
|                                     | Rear blade down                     | *14.3       | 9.1   | *10.3 | 5.9   | *8.1 | 4.2  | *6.6 | 3.1  |      |      | 5.6           | 2.5  |       |
|                                     | Rear outrigger down                 | *14.3       | 11.6  | *10.3 | 7.3   | *8.0 | 5.1  | 6.1  | 3.8  |      |      | 4.9           | 3.0  |       |
|                                     | Front outrigger and rear blade down | *14.3       | 13.9  | *10.3 | 8.8   | *8.1 | 6.2  | *6.6 | 4.6  |      |      | *5.7          | 3.7  |       |
| Front blade and rear outrigger down | *14.3                               | *14.3       | *10.3 | *9.2  | *8.1  | 6.6  | *6.6 | 4.8  |      |      | 5.5  | 3.9           |      |       |
| -2 m                                | 4 outrigger down                    | *14.3       | *14.3 | *10.3 | 10.3  | *8.1 | 7.5  | *6.6 | 5.6  |      |      | 5.7           | 4.5  |       |
|                                     | Rear blade up                       | 9.0         | 7.6   | 5.8   | 5.0   | 4.0  | 3.5  | 3.0  | 2.6  |      |      | 2.7           | 2.4  | 6.3   |
|                                     | Rear blade down                     | *14.5       | 9.0   | *10.5 | 5.8   | *8.3 | 4.0  | *6.6 | 3.0  |      |      | *6.1          | 2.7  |       |
|                                     | Rear outrigger down                 | *14.5       | 11.5  | *10.5 | 7.2   | *8.3 | 4.9  | 6.0  | 3.6  |      |      | 5.5           | 3.4  |       |
|                                     | Front outrigger and rear blade down | *14.5       | *14.2 | *10.5 | 8.8   | *8.3 | 6.0  | *6.6 | 4.4  |      |      | *6.1          | 4.1  |       |
| Front blade and rear outrigger down | *14.5                               | *14.5       | *10.5 | 9.4   | *8.3  | 6.3  | *6.6 | 4.7  |      |      | *6.1 | 4.3           |      |       |
| -3 m                                | 4 outrigger down                    | *14.5       | *14.5 | *10.5 | *10.5 | *8.3 | 7.4  | *6.6 | 5.4  |      |      | *6.1          | 5.0  |       |
|                                     | Rear blade up                       | 8.9         | 7.5   | 5.5   | 3.9   | 3.3  |      |      |      |      |      | 3.3           | 2.8  | 5.55  |
|                                     | Rear blade down                     | *14.9       | 8.9   | *10.7 | *7.8  | 3.9  |      |      |      |      |      | *6.4          | 3.3  |       |
|                                     | Rear outrigger down                 | *14.9       | 11.4  | *10.7 | *7.8  | 4.8  |      |      |      |      |      | *6.4          | 4.1  |       |
|                                     | Front outrigger and rear blade down | *14.9       | 14.5  | *10.7 | *7.8  | 5.9  |      |      |      |      |      | *6.4          | 5.0  |       |
| Front blade and rear outrigger down | *14.9                               | *14.9       | *10.7 | *7.8  | 6.2   |      |      |      |      |      | *6.4 | 5.3           |      |       |
| 4 outrigger down                    | *14.9                               | *14.9       | *10.7 | *7.8  | 7.3   |      |      |      |      |      | *6.4 | 6.1           |      |       |



## Standard Equipment

Standard equipment may vary by country, so please consult your Hitachi dealer for details.

### ENGINE

- The engine conforms to EU stage II standards
- Turbocharged, intercooled
- The radiator, oil cooler and intercooler are all made of aluminum
- H/P mode control
- E mode control
- 50 A alternator
- Dry-type air filter with evacuator valve (with safety element)
- Cartridge-type engine oil filter
- Cartridge-type fuel filter
- Radiator and oil cooler with dust protective net
- Radiator reserve tank
- Fan guard
- Isolation-mounted engine
- Auto-idle system
- Auto acceleration system

### HYDRAULIC SYSTEM

- Work mode selector
- Engine speed sensing system
- E-P control system
- Quick warm-up system for pilot circuit
- Shockless valve in pilot circuit
- Boom-arm anti-drift valve
- Brake valves for travel circuits
- Accumulator in pilot circuit
- Control valve with main relief valve
- Extra port for control valve
- Suction filter
- Full-flow filter
- Pilot filter

- Steering filter
- Outriggers are individually controlled

### CABIN

- CRES (Center pillar Reinforced Structure) cabin
- All-weather sound-suppressed steel cab
- Reinforced, tinted (green color) glass windows
- 4 fluid-filled elastic mounts
- Windows on upper, lower-front and left side can be opened
- Intermittent windshield retractable wipers
- Front window washer
- Transparency roof (with roll curtain)
- Adjustable suspension seat with armrests
- Footrest
- Electric double horn
- AM - FM radio with digital clock
- Auto-idle / acceleration selector
- Seat belt
- Drink holder
- Cigar lighter
- Ashtray
- Storage box
- Glove compartment
- Floor mat
- Pilot control shut-off lever
- Engine stop knob
- Information controller
- Auto control air conditioner

### MONITOR SYSTEM

- Meters: Speedometer, hourmeter and tripmeter, engine coolant temperature gauge, hydraulic brake pressure gauge, fuel gauge
- Warning lamps: Alternator charge, brake pressure warning indicator, engine oil pressure, engine overheat, travel motor warning indicator, air filter restriction and minimum fuel level
- Pilot lamps: Work light, auto-idle and auto-acceleration, digging mode and attachment mode, engine preheat, turn signals, head light high beam, parking brake, digging brake, axle lock, hazard warning signals, shift lever (N/D/L), clearance light, outrigger/dozer, blade operation
- Alarm buzzers: Front attachment operation while parking brake is on, engine oil pressure, engine overheat, and brake pressure

### LIGHTS AND SIGNALS

- Two headlights
- Working light
- Combination lamps
- Turn signal lamps
- Brake lamps
- Clearance lamps
- Hazard lamps

### UPPERSTRUCTURE

- Undercover
- Fuel level float
- Hydraulic oil level gauge
- Rearview mirrors, left and right
- Swing parking brake
- Swing lock

### UNDERCARRIAGE

- Parking brake
- Toolbox; left chassis
- Traction type pattern tires (10.00-20-14 PR)
- Tire spacer

### FRONT ATTACHMENTS

- HN bushing
- WC thermal spraying
- Reinforced resin thrust plate
- Flanged pin
- Bucket clearance adjust mechanism
- Centralized lubrication system
- Dirt seal on all bucket pins

### MISCELLANEOUS

- Standard tool kit
- Lockable machine covers
- Lockable fuel filling cap
- Skid-resistant tapes, plates and handrails
- Travel direction mark on chassis frame

## Optional Equipment

Optional equipment may vary by country, so please consult your Hitachi dealer for details.

### CABIN

- Full seat screw on the cab
- Roof guard for cab
- Upper front guard for cab
- Low front guard for cab
- Suspension seat with heater
- Air suspension seat with heater
- Immobilizer key
- 12 V power source
- Vandal cover for cab
- Rotating lamp
- OPG top and front guard level 2 (ISO) compliant cab

### LIGHTS

- Additional cab roof front light
- Additional cab roof rear light
- Additional boom light with cover

### FRONT ATTACHMENTS

- 2-piece boom
- 2.25 m arm
- 3.20 m arm
- Other variety buckets
- Reinforced arm

### UNDERCARRIAGE

- Short chassis
- Rear dozer blade
- Rear outriggers
- Front dozer blade + rear outriggers
- Front outriggers + rear dozer blade
- Front outriggers + rear outriggers
- Right toolbox
- Twin tire 11:00-20

### ATTACHMENT

- Parts for hammer and crusher
- Hammer and crusher piping
- Assist piping
- Clamshell piping
- Quick coupler piping

### OTHERS

- Hose rupture valve (boom) with overload warning device
- Hose rupture valve (arm)
- Hose rupture valve (positioning)
- Pre-cleaner
- Fuel double filter
- Biodegradable oil
- High-performance full flow filter (with restriction indicator)
- Electric fuel refilling pump





**Hitachi Construction Machinery (Europe) NV**

Souvereinstraat 16, 4903 RH Oosterhout, P.O. Box 404, 4900 AK Oosterhout, The Netherlands  
T +31-(0)162 48 44 00, F +31-(0)162 45 74 53, [www.hcme.com](http://www.hcme.com)

Siciliëweg 5, Haven 5112, 1045 AT Amsterdam, P.O. Box 59239, 1040 KE Amsterdam, The Netherlands  
T +31-(0)20 44 76 700, F +31-(0)20 33 44 045, [www.hcme.com](http://www.hcme.com)



**Breaking  
new  
ground**

**HITACHI**