



M320

Wheel Excavator

Cat® 3116 T Engine	98 kW/131 hp
Operating Weight	19 400 to 20 650 kg
Bucket Capacities	0.41 to 1.35 m ³
Maximum	
Reach at Ground Level	11 180 mm
Digging Depth	7680 mm
Travel Speed	20 km/h

The Cat M320 wheel excavator

Setting a high standard in mobility, versatility, operator comfort and ease of maintenance.

The 300 Family sleek styling on wheels

Both the cab and body have smooth, rounded contours with blended-in roading lights for a modern look. The cab interior combines modern styling with a soft and pleasing color scheme. The M320 offers everything an operator could expect today in a wheel excavator.

A step forward in environmental considerations

The Caterpillar 3116 T engine meets regulatory emissions requirements worldwide, including the European Union Non-Road Mobile Machinery Engine Emission Directive 97/68/EC.

The engine has low spectator and operator sound levels and the hydraulic system can be operated with bio-degradable oil as an option. These features make the M320 a friendly machine, which helps protect the environment. **pg. 8**



State-of-the-art hydraulic system

The load-sensing hydraulic system with load independent flow distribution offers exceptional operation control, modulation, and multi-function capability. Up to four additional hydraulic functions can be added for maximum application flexibility. **pg. 10**

Modern electronics

A microprocessor together with modern electronics register the operator's commands and manage the engine and pump interface to help maximize fuel efficiency. **pg. 6-7**

Ground level maintenance

All daily maintenance points are accessible from ground level. A centralized greasing port is located on the right foot of the boom. This allows the operator to grease the front linkage pins from ground level. **pg. 10**

A choice of the best boom and stick match

2 booms and 5 different sticks allow you to choose the best match for each job. Computer aided design and stress analysis of all front-end structures give the best combination of durability and weight control. **pg. 9**

The cab: a new reference

Pilot operated joysticks control front-end and swing functions. The tiltable steering column and the pedal controls offer optimal comfort. The control panel informs the operator of the machine status at all times. Large windows offer good visibility while roading and working in tight quarters. The fully adjustable seat offers lumbar support. Heater, defroster, and fan keep positive filtered air (warm, fresh, or cool if equipped with the air conditioner option) flowing through the cab at the flip of a switch. **pg. 4-5**



Cat '5 Star Customer Service'

Turns your investment into profit, from purchase to resale through:

- Equipment Management Services for optimum profit
- Maintenance Services for equipment protection
- Predictive Services for optimum availability
- Reconditioning Services for lower repair cost
- Your Caterpillar dealer for satisfaction and peace of mind

pg. 23

Outstanding operator comfort

Plenty of room, all-around visibility, and ergonomic layout for convenient operation.

Easy access

Conveniently located grab irons and large steps mounted on the undercarriage allow easy access to the cab.

A quiet cab

The cab is resiliently mounted. Sound suppression panels considerably reduce outside noise levels.

A comfortable seat

The suspension seat adjusts to the operator's weight and offers excellent lumbar support. There are height-adjustable armrests and numerous seat adjustments.

Outstanding visibility

Wide windows help ensure excellent visibility in all directions. This is especially critical when roading the machine or when working on public roadways. A parallelogram windshield wiper clears the front window efficiently in rainy weather. Rear visibility is excellent thanks to the small engine cover. The standard skylight provides upward visibility.

Excellent ventilation

Strategically located vents circulate forced air, heat, or defrost air for maximum comfort. The two-piece front window has multiple positions. In rainy weather, the lower front window can be tilted inwards to provide fresh air and the skylight can be opened for additional ventilation. For work in hot weather conditions, an optional air conditioner is available.

Practical controls

- The control panel switches are conveniently located.
- Warning lights are clearly visible on the upper portion of the control panel.
- Joysticks require low effort and a short stroke for maximum control and efficiency.
- Ample space is reserved for the additional switches and pedals used to activate optional equipment.





Maestro Mobile electronic system

An electronic system matching the state-of-the-art hydraulic system designed specifically for wheel excavator applications.

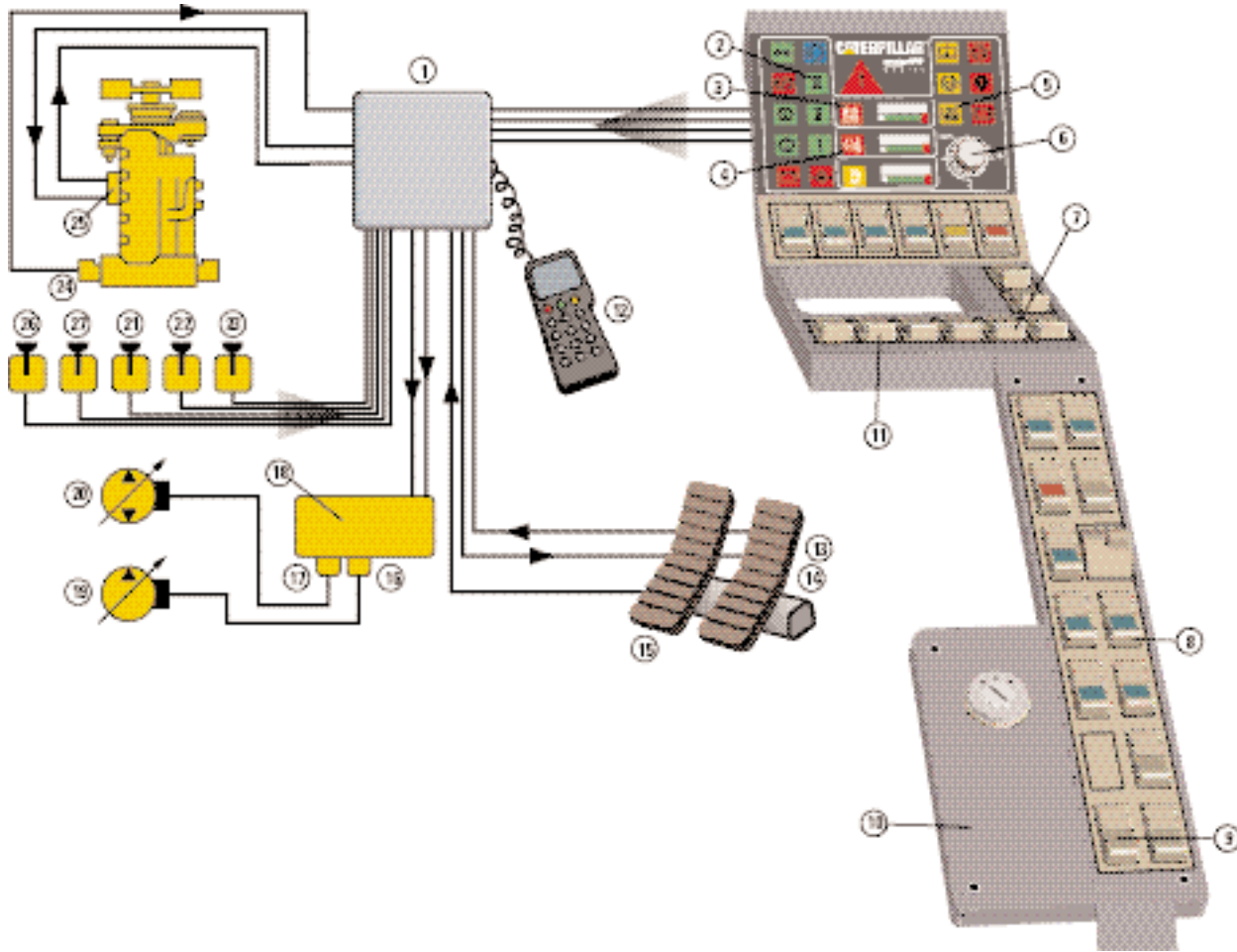

- | | | |
|--|---|---|
| 1 Microprocessor | 10 RH console | 19 Main pump |
| 2 Power mode III indicator | 11 Power mode switch (I/II) | 20 Swing pump |
| 3 Hydraulic oil temperature – high | 12 Diagnostic tool or laptop-PC running <i>Cat Electronic Technician (ET)</i> software | 21 Brake light switch |
| 4 Engine coolant temperature – high | 13 Travel pedal switch | 22 Pressure switch – AEC Main pump |
| 5 Hydraulic oil temperature – low | 14 Travel pedal magnet | 23 Pressure switch – AEC Swing pump |
| 6 Engine speed dial | 15 Brake light pressure switch | 24 Engine speed pick-up |
| 7 Travel lock switch | 16 Main pump PRV | 25 Governor actuator and feedback sensor |
| 8 Automatic engine control (AEC) switch | 17 Swing pump PRV | 26 Pressure switch – AEC stick cylinder |
| 9 Back-up switch | 18 Pilot manifold | 27 Pressure switch – AEC boom cylinder |

State-of-the-art hydraulic system

Closed center, variable flow, load-sensing plus. A variable displacement piston pump powers the boom, stick, bucket, outriggers/dozer, and travel circuit.

A gear pump powers the steering system, the brake system, and the pilot control system, and, if equipped, the medium pressure function.

A dedicated swing pump

A separate dedicated variable displacement piston pump and fixed displacement piston motor power the swing mechanism. This closed hydraulic circuit helps to provide maximum swing performance and control at all times.

An efficient and expandable hydraulic system

Up to four optional hydraulic valves can be added to the main valve stack for additional hydraulic functions.

A medium pressure auxiliary hydraulic circuit is also available. These features offer almost unlimited auxiliary hydraulic capability.

Maestro Mobile Control Panel

The right side console, shown on page 6, contains switches for the power mode selector, automatic engine control, lights, windshield wiper and washer, and travel speed selector.

Integrated electronic system

A microprocessor monitors and controls all M320 parameters and functions. The microprocessor was designed specifically for a wheel excavator to maximize the efficiency of the engine and the hydraulic system.

This Electronic Control System monitors and controls the following functions:

Engine Speed Control Via Potentiometer – The diesel final control element at the diesel engine is controlled via a potentiometer in the instrument panel. A button on the right joystick immediately sets the idle down manually.

Three power mode settings – There are three power mode settings. The operator can choose the best power setting for both engine and hydraulics, without any loss of hydraulic force.

Mode III – Works only during travel and is automatically engaged. It provides maximum speed and drawbar pull.

Mode II – The standard mode, used for normal truck loading, trenching, and hydraulic hammer use.

Mode I – The economy mode, used for lifting, pipe setting, bank forming, grading, slope finishing, and close quarter and precise work. This mode helps ensure minimum fuel consumption.

Automatic Engine Speed Control – When activated, this device reduces engine speed to a minimum during periods of inactivity. This reduces noise and saves fuel.

Electronic Underspeed Control – Constant electronic monitoring assures that the pump output is always matched to diesel engine power. As a result, a nearly constant diesel engine speed can be maintained.

Protective Measures – Maximum power is reduced when engine temperature is too high or the hydraulic temperature is either too low or too high.

Diagnostic System – System parameters and failure identification codes can be read by means of a diagnostic tool.

Top Speed Adjustment (optional) – This holds the travel pedal in the maximum position to reduce strain on the operator. The pedal is released by activating the brake.

Cat 3116 T engine

An emission controlled engine offering the latest environmental benefits.

- Conservative 98 kW rating, high power to displacement ratio of 15.2 kW/liter and low rpm operation help ensure long life and exceptional reliability.
- The 3116 T engine meets the European Union 97/68/EC Non-Road Mobile Machinery Engine Emission Directive and the current US EPA Non-Road Regulation.
- Four-stroke-cycle design uses long power strokes for more complete fuel combustion and efficiency. Accurate fuel metering results in low fuel consumption.
- Long-life design includes large bearing surfaces, alloy steel valves, lightweight cam roller followers, and easily replaceable crankshaft seals.
- The engine is designed for high torque rise at medium rpm. This is suited for excavator applications.
- The engine is longitudinally mounted on the right to make it easier to serve the oil filter, oil filler, oil drain valve, fuel filter, V-belt tightener, and dipstick which are all accessible from ground level.
- Low engine noise emissions make the M320 a real friendly machine which helps protect the environment:
 $L_{pA} - 72 \text{ dB(A)}$;
 $L_{wA} - 102 \text{ dB(A)}$

Dynamically measured according to ISO6396 or 95/27/EC.



Undercarriage, outriggers, dozer blade, axles

Undercarriage and axles match: providing maximum flexibility and mobility.

Undercarriage – A strong and long-life welded frame structure built with large sections and thinner plates for excellent rigidity. The frame has been Finite Element Method analyzed. Both the dozer blade and the outriggers feature a pin-on design.

Axles – Heavy duty axles. The front axle offers one of the best axle oscillation and steering in the industry for optimized flexibility and mobility.

Outriggers – Recommended for maximum operation stability when digging and lifting. They can be controlled individually to level the machine on slopes. Pin-on design, including standard outriggers cylinder guards. Can be mounted on the front and/or on the rear.

Dozer Blade – A useful addition for leveling and backfilling or clean-up work, also used to improve machine stability when digging or lifting. Pin-on design, including standard dozer blade cylinders guard. This can be mounted on the front and/or on the rear.

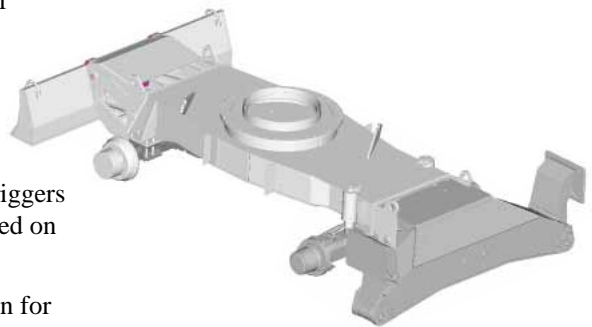

Booms and sticks

Choose the boom/stick combination best matching your needs. Contact your Cat dealer for more information.

1 One-piece Boom 5.65 meters – For all standard applications. It is built with large sections and thinner plates for maximum weight reduction and durability and has been Finite Element Method analyzed. Recommended for hammer applications.

2 Hydraulically Adjustable Boom (VA) max. 5.41 meters – For improved visibility and machine roading balance. Indicated when working in tight quarters. It is built with large sections and thinner plates for maximum weight reduction and durability and has been Finite Element Method analyzed.

Sticks – 5 stick lengths are available for maximum flexibility. They are built with large sections and thinner plates for maximum weight reduction and durability. They have been Finite Element Method analyzed.

- Short stick: 1.9 m
- Medium stick: 2.5 m
- Long stick: 2.9 m
- Extra long stick: 4.2 m
- Material handling stick: 3.4 m.

Industrial arrangement – For industrial or agricultural applications choose the best matching boom and the 3.4 m industrial droop nose stick. With this stick, a free swinging work tool can be used.

Bucket linkage – Two bucket linkages are offered. One with diverter valve, the other without.

3 Finite Element Analysis – With FEA, a most stable and reliable base frame and upper frame structure could be designed. For maximum strength and best range, also all linkage parts (boom, sticks) have been analyzed to help optimize the balance of weight reduction versus fatigue strength. This also includes the offset boom.

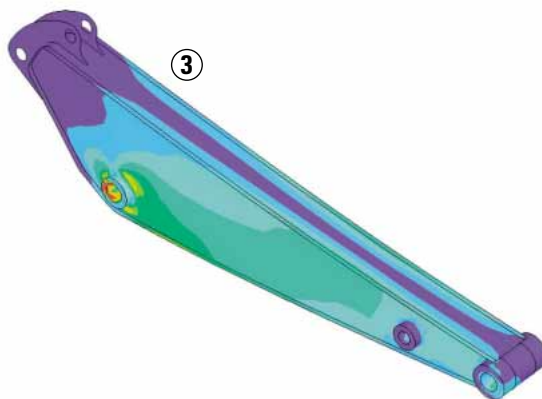

Hydraulics

The M320 hydraulic system provides more performance and efficiency to your jobs.

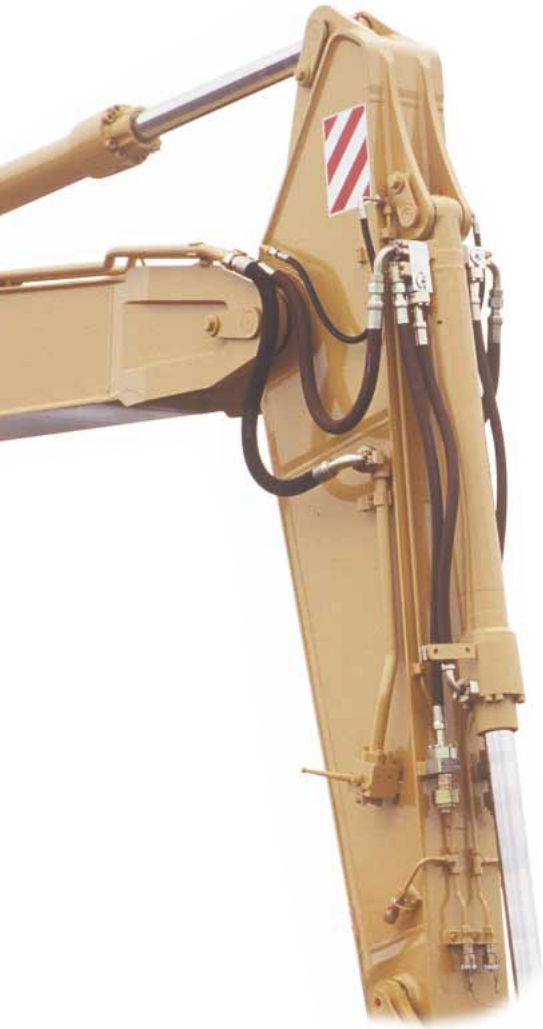

Efficient and expandable hydraulic system – The flow distances between hydraulic components are minimized. This helps provide maximum hydraulic efficiency. The load independent flow distribution together with the separate swing pump helps ensure maximum power at all times.

- Load independent flow distribution and control system with pressure cut-off. The pump flow is independently and proportionally distributed to the flow users. This is a flow-on-demand hydraulic system offering multi-function capability.
- Optional hydraulic valves can be flanged to the main valve stack for maximum hydraulic flexibility.

Caterpillar XT hoses and couplings – meet the critical flexibility and strength demands of wheel excavator applications. O-ring face seal couplings provide positive sealing for reliable and leak-free connections.

Hammer Lines (optional) – Factory installed hammer hydraulic lines are available. These lines allow single acting function for dedicated proportional hammer foot control for maximum comfort and precision. Optimized hose routing provides excellent protection and durability.

High Pressure Hydraulic Lines (optional) – Factory installed high pressure lines are available. They are designed to function with 2-way hydro-mechanical attachments such as shears and crushers at maximum working pressure and flow. Optimized hose routing provides excellent protection and durability.

Medium Pressure Hydraulic Lines (optional) – Factory installed medium pressure lines are available. They are designed to function with double-acting rotating devices such as the ditch cleaning bucket tilt and the clamshell rotation. Optimized hose routing provides excellent protection and durability.

Serviceability

Simplified service and maintenance features save you time and money.

Fast, easy maintenance means improved uptime and better value.

Ground level service points for fuel-water separator, engine oil filter, battery, radiator fluid level, window washer fluid level, fuel filter, engine oil gauge, hydraulic oil level, air cleaner and pilot system filter.

Filters and filter locations make maintenance easier.

- Air cleaner has double layered filter core and built-in air precleaner for better filtration. No tools required to change.
- Operator is alerted by warning light in cab to need for filter change.
- Engine oil filter, fuel filter and fuel-water separator are positioned for easier access.
- Pilot hydraulic system filter keeps contaminants away from the pilot system.

Water separator removes water from fuel even when under pressure and is located in the engine compartment.

Remote greasing block on the upper frame with two grease points for the swing bearing and one for the front end attachment to deliver grease to hard to reach locations.

Buckets and work tools

A wide variety of buckets and work tools help optimize machine performance. Purpose designed and built to Caterpillar's high durability standards.

Work Tools – A variety of work tools are available from your Cat dealer for the M320 wheel excavator. These include quick couplers, different kinds of grapples, and demolition and sorting tools such as shears, pulverizers, or hydraulic hammers.

Tip selection

The following tips are available for the buckets for the M320:

- Long Tips
- Short Tips
- Abrasive Tips
- Penetration Tips
- Sharp Corner Tips
- Wide Tips

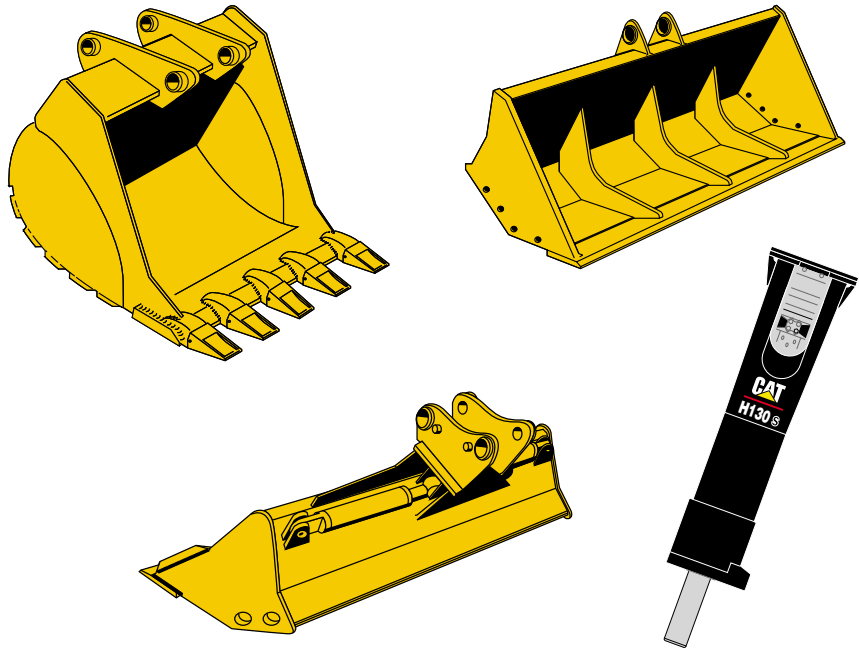

Bucket specifications

		General Purpose							
A	Bite width	mm	600	750	1000	1100	1250	1400	1500
B	Tip radius	mm	1423	1423	1423	1423	1423	1423	1423
	SAE rated capacity	m ³	0.41	0.55	0.81	0.90	1.05	1.20	1.35
	Weight with tips	kg	540	560	600	685	740	780	810
	Number of teeth		3	3	4	5	5	6	6
		Extreme Service		Ditch Cleaning					
A	Bite width	mm	1200	1250	1800	2000	2000	2300	2000
B	Tip radius	mm	1340	1423	1244	1300	1400	1244	896
	SAE rated capacity	m ³	0.90	1.05	0.48	0.58	0.70	0.62	0.70
	Weight with tips	kg	710	750	*477	*680	*720	*569	640
	Number of teeth		5	5					
					Tilttable	Tilttable	Tilttable	Tilttable	Rigid

All buckets include weld-on tooth adapters.

All buckets are available with or without adjuster group:

All weights are with tips.

* J300 tips required, buckets without * require J250 tips.

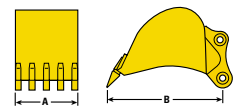

Buckets (optional) – A complete range of Cat specifically designed general purpose buckets are available for maximum flexibility.

All are available either with or without adjuster groups.

A range of tilttable and rigid ditch cleaning buckets are also available.

Tips can be chosen from the J250 / J300 G.E.T offering.

Engine

Caterpillar four-stroke-cycle, six cylinder 3116 T turbocharged diesel engine.

Ratings at 2300 rpm	kW	hp
Gross power	104.5	140
Net power	98	131

The following ratings apply at 2300 rpm when tested under the conditions for the specified standard:

Net power	kW	hp
ISO 9249	98	131
EEC 80/1269	98	131

Dimensions

Bore	102 mm
Stroke	130 mm
Displacement	6.6 liters
Maximum torque	608 Nm
Torque rise	19% at 1400 rpm

- An emission controlled engine. Meets the 97/68/EC Non-Road Mobile Machinery Engine Emission Directive and the current US EPA Non-Road Regulation.
- Longitudinal mounting on the right for easy ground access for service/maintenance of: oil filter, oil filler, oil drain valve, fuel filter, V-belt tightener, dipstick.
- An electric 24-volt starting system with a 55 amp alternator and two, 12-volt, 100 amp hour Caterpillar Maintenance-Free batteries.
- An air cleaner, dry type with radial seal primary and secondary element. Easy and rapid to service and replace.
- Maximum altitude at full power: 2950 meters.

Environmental features

The M320 offers a list of features to help protect the environment.

- Low fuel consumption. Compared to power and performance, the M320 has a low level of fuel consumption.
- Biodegradable hydraulic oil. On the M320, you can use a biodegradable hydraulic oil to help protect the environment and meet governmental requirements in certain countries.
- The M320 features extremely low operator and spectator sound levels.
- The emission controlled engine complies with the 97/68/EC Non-Road-Machinery Engine Emission Directive.

Emission values	g/kWh
Hydrocarbons (HC)	below 1.3
Carbon Monoxide (CO)	below 5.0
Nitrogen Oxide (NO _x)	below 9.2

Noise levels

L_{pA} – 72 dB(A); L_{WA} – 102 dB(A)

Dynamically measured according to ISO6396 or 95/27/EC.

Brakes

Maintenance free wet-disc service brakes on the front and rear axles are standard.

- A fully hydraulic service brake system. Braking system is supplied with hydraulic oil from a separate gear pump mounted on the engine.
- A dual-circuit braking system with independent front and rear axle service brake circuits, for increased safety.
- Two separate pre-charged hydraulic accumulators, one per circuit, for increased safety.
- A disc brake parking brake located in the transmission housing. Spring applied and hydraulically released.

Axles and final drives

Planetary axles with planetary gear reduction final drives located in the axle hubs.

- All-wheel drive.
- High quality graphite iron axle housings for maximum strength and durability.
- Front steering axle oscillates 9° for improved stability and manoeuvrability in rough terrain.
- Front axle can be locked from operator station in any position of oscillation for improved working stability.

Ground clearance (with standard tires)	360 mm
Axle static load capacity	40 000 kg

Hydraulic system

Main Hydraulic System

Maximum flow	320 l/min
Maximum pressure	
Implements	330 bar
Travel	330 bar
Optional heavy lift circuit	370 bar

Pilot System

Maximum flow	15 l/min
Maximum pressure	32 bar

Maestro Mobile electronic control system

The microcontroller monitors and controls the interference between the engine and the hydraulics.

- Automatically passes into power mode III to help maximize power when travel is activated.
- Balances pump output and engine power in power modes I and II to help maximize efficiency.
- Automatic engine control (AEC), provides automatic engine low idle for noise and fuel reduction and operator comfort.
- 3 power modes: travel mode, standard mode, economy mode.
- The electrical back-up system for the microprocessor is standard. The switch is in the cab.
- The central diagnostic function records system parameters or faults. It can be read by dealer technicians with portable diagnostic tools for fast analysis and troubleshooting.

Steering

Fully hydraulic, powered by a separate gear pump mounted on the engine.

- Maintenance-free steering system.
- Synchronized steering cylinder integrated in the steering axle housing to help maximize protection.
- Steering angle of 35° for reduced turning circle and mobility.
- Optional battery-powered supplemental steering system.

Outer turning circle diameter	13.5 m
Vehicle clearance turning circle	
with one-piece boom	18.8 m
with VA boom	15.5 m

Transmission

2-gear power-shift transmission. Permanent all wheel drive.

- Forward, reverse travel and speed are controlled by a single foot pedal on the right side of the steering column.
- The transmission is protected by a downshift governor to help prevent high-to-low shift until pre-set slower ground speed is reached.
- The overspeed valve limits downhill travel speed in forward and reverse gears.
- An optional two-piece drive shaft with an intermediate bearing to help maximize ground clearance is available.
- The transmission is flanged to the differential housing of the rear axle for maximum protection by axle and base frame, and for better ground clearance.
- Standard creeper speed.
- Optional travel speed lock for operator comfort. This locks the travel pedal for long distance travelling.

Speeds

1st gear, forward/reverse	5 km/h
2nd gear, forward	20 km/h
2nd gear, reverse	20 km/h
Creeper speed (first gear)	2-3 km/h
Creeper speed (second gear)	11-16 km/h
Drawbar pull	105 kN
Gradeability	57%

Tires

Dual pneumatic 11.00-20 tires are standard.

Optional tires:

- 10.00-20 (dual solid rubber),
- 18R 19.5 XF (super single).
- 18R 22.5 XF (super single).

Service refill capacities

	Liters
Fuel Tank	370
Cooling	35
Lubrication	
Engine	21
Rear axle housing, differential	12
Front steering axle, differential	11
Final drives, front (each)	2
Final drives, rear (each)	1.5
Powershift transmission	3
Hydraulic system (including tank)	300
Hydraulic tank	205

Controls

Two pilot-operated revolver type hand levers actuate boom, stick, bucket and swing (SAE pattern).

Right lever

- Move forwards and backwards to lower and raise boom,
- Move left and right to control bucket curl and dump,
- Press button on top of control to activate the optional auxiliary circuit in one direction.

Left lever

- Move forwards and backwards to move stick out and in,
- Move left and right to control the direction of swing,
- Press button on top of control to activate the optional auxiliary circuit in one direction.
- Press single button on top of control to activate the swing brake.

Pedals to the right of the steering column

- Service brake pedal is immediately to the right of the steering column. Fully depressed brake pedal automatically locks oscillating axle
- Forward and reverse rocker travel pedal is located to the right of the service brake pedal.

Pedals to the left of the steering column

- Optional VA boom rocker control pedal is immediately to the left of the steering column,
- Optional hammer or auxiliary hydraulic high pressure function control pedal is located to the left of the VA boom rocker control pedal.

Left side console lifts for operator entry and exit. Raising the side console isolates all hydraulic functions except steering. This console must be raised to start the engine.

Swing mechanism

Dedicated variable displacement axial-piston pump and fixed-displacement axial-piston motor powers the swing mechanism.

- Closed hydraulic circuit, flow and torque controlled with pressure cut-off for maximum swing performance and control. Swing output is power mode influenced.
- Double-reduction, planetary swing drive.
- Splash lubricated.
- Maintenance free gear mechanism.
- Adjustable constant brake torque while coasting when the swing control is released.
- Maximum holding torque at operating pressure in a standstill position.
- Automatic swing brake is activated after 3.5 seconds of no swing operation. Additional emergency swing brake button on joystick.
- Standard manual swing lock pin actuated from the cab for machine transportation.

Swing system

Maximum flow	112 l/min
Maximum pressure	340 bar
Swing torque	56.6 kNm
Max. swing speed	9.4 rpm

Weights

Average operating weights include general purpose bucket, 100% fuel and operator. An optional additional counterweight of 600 kg is available.

Stick	One-piece boom 1 set of outriggers/dozer kg	VA boom dozer only kg
1900 mm	20 360	19 410
2500 mm	20 380	19 470
2900 mm	20 520	19 610
4200 mm	20 640	19 730

For the following equipment change the above weights:

One-piece boom	–	-620
VA boom	+620	–
Dozer only	-1280	–
1 set of outriggers only	-900	+380
2 sets of outriggers	+380	+1660
1 set of outriggers/dozer	–	+1280

Undercarriage with dozer only

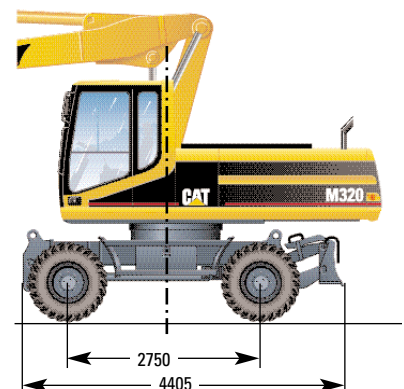

Dimensions

All dimensions are approximate – measured in mm

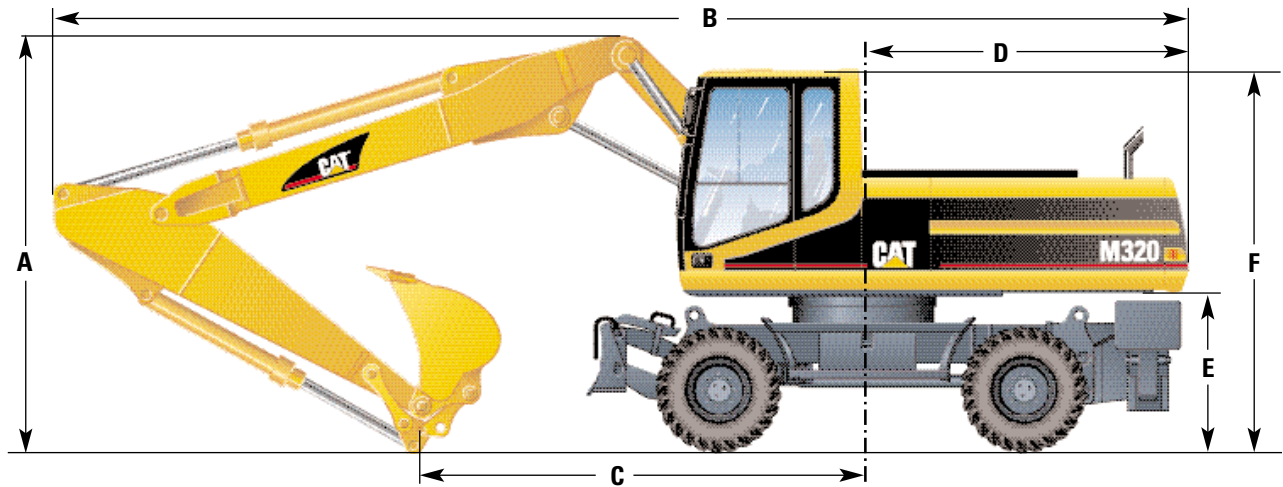

	One-piece boom	VA boom
A Shipping height	1900 mm stick	3280
	2500 mm stick	3210
	2900 mm stick	Cab height
	4200 mm stick	*3470
		*3400
B Shipping length	1900 mm stick	9770
	2500 mm stick	9550
	2900 mm stick	9660
	4200 mm stick	*9700
		*9270
C Support Point	1900 mm stick	4810
	2500 mm stick	3670
	2900 mm stick	3060
	4200 mm stick	*2280
		*2150

D Tail swing radius	2700
E Counterweight clearance	1310
F Cab height	3145

* Bucket removed

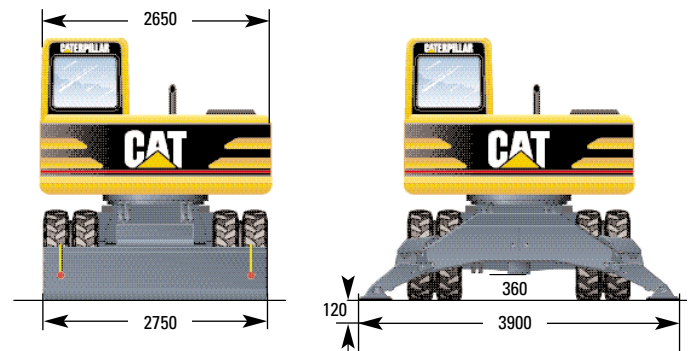

Undercarriage with 2 sets of outriggers

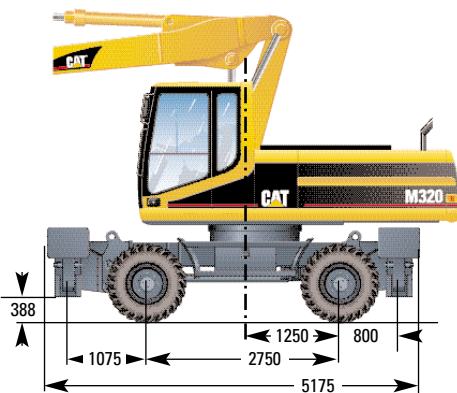

Undercarriage with 1 set of outriggers and dozer

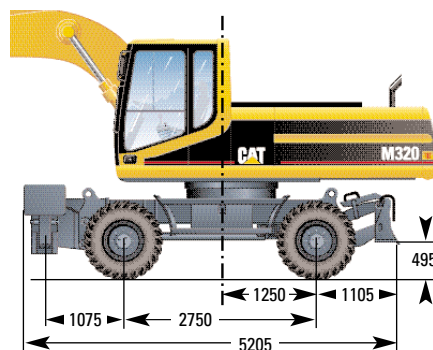

Roading position with 2.5 m stick

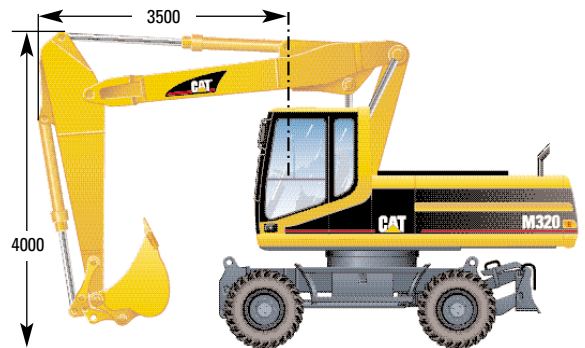

Working ranges

With one-piece boom

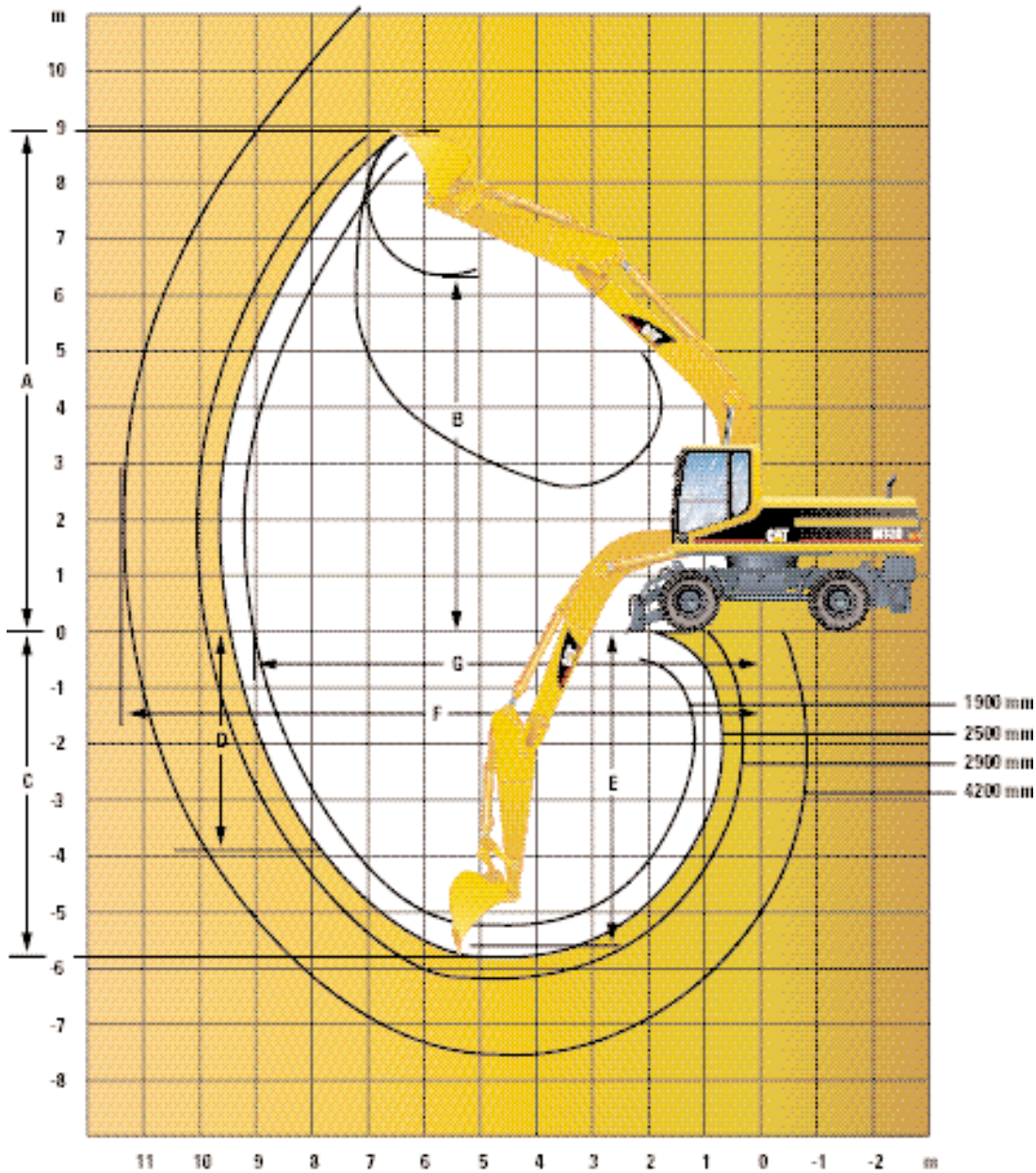

Stick	1900 mm	2500 mm	2900 mm	4200 mm
Bucket	1.05 m³	0.90 m³	0.81 m³	0.55 m³
A Maximum cutting height	8620 mm	8970 mm	8800 mm	9500 mm
B Maximum loading height	6060 mm	6300 mm	6210 mm	6840 mm
C Maximum digging depth	5190 mm	5790 mm	6190 mm	7470 mm
D Maximum vertical wall digging depth	2460 mm	3910 mm	3670 mm	5340 mm
E Maximum depth of cut, for 2500 mm level bottom	4940 mm	5580 mm	6000 mm	7350 mm
F Maximum reach	9250 mm	9800 mm	10 070 mm	11 340 mm
G Maximum reach at ground level	9050 mm	9610 mm	9900 mm	11 180 mm
Digging forces (SAE):				
Stick	130 kN	99 kN	90 kN	69 kN
Bucket	137 kN	127 kN	127 kN	127 kN

Working ranges

With VA boom.

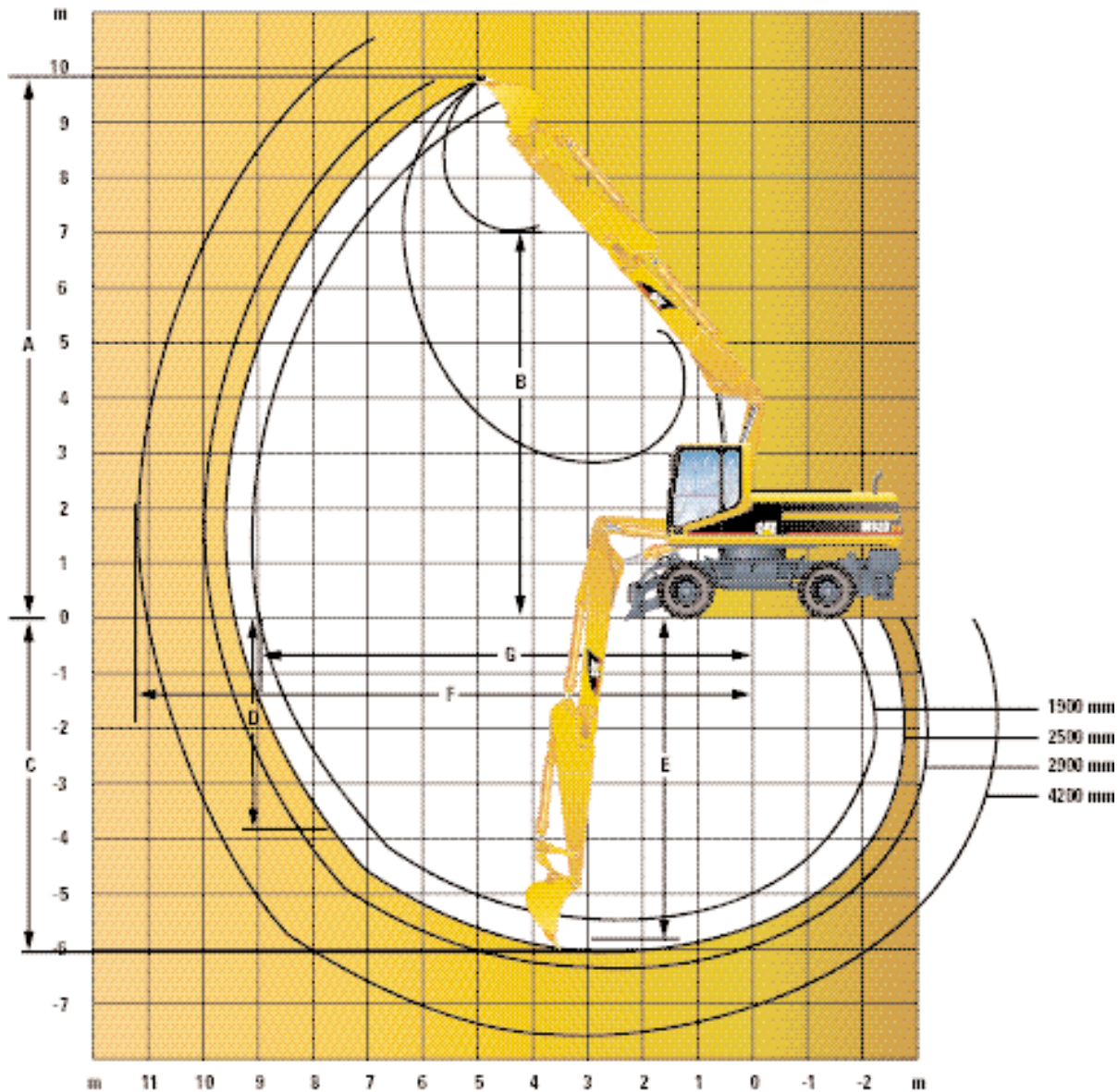

Stick	1900 mm	2500 mm	2900 mm	4200 mm
Bucket	1.05 m³	0.90 m³	0.81 m³	0.55 m³
A Maximum cutting height	9370 mm	9790 mm	9740 mm	10 630 mm
B Maximum loading height	6660 mm	7040 mm	7100 mm	7900 mm
C Maximum digging depth	5420 mm	6010 mm	6380 mm	7680 mm
D Maximum vertical wall digging depth	2460 mm	3850 mm	3640 mm	5280 mm
E Maximum depth of cut, for 2500 mm level bottom	5000 mm	5620 mm	6000 mm	7360 mm
F Maximum reach	9020 mm	9570 mm	9850 mm	11 120 mm
G Maximum reach at ground level	8820 mm	9380 mm	9670 mm	10 960 mm

Digging forces (SAE):

Stick	130 kN	99 kN	90 kN	69 kN
Bucket	137 kN	127 kN	127 kN	127 kN

Lift capacities**

with one-piece boom – 5.65 m

Stick
1.9 m

Bucket
1.05 m³

Stick 1.9 m	Undercarriage configuration	3.0 m			4.5 m			6.0 m			7.5 m			m
6.0 m	Rear dozer up Rear dozer down Rear stab down 2 sets stab down Dozer and stab down							*5.0 *5.0 *5.0	*5.0 *5.0 *5.0	3.2 3.7 4.5				
4.5 m	Rear dozer up Rear dozer down Rear stab down 2 sets stab down Dozer and stab down							5.2 *5.5 *5.5	3.1 3.6 4.4	3.4 *5.0 4.9	1.9 2.3 2.9			
3.0 m	Rear dozer up Rear dozer down Rear stab down 2 sets stab down Dozer and stab down							4.9 *6.3 *6.3	2.9 3.4 4.2	3.4 *5.2 4.8	1.9 2.6 2.8	2.6 *3.2 *3.2	1.4 1.7 2.2	8.89
1.5 m	Rear dozer up Rear dozer down Rear stab down 2 sets stab down Dozer and stab down							4.7 *7.1 *7.1	2.7 3.2 4.0	3.3 5.4 4.7	1.8 2.2 2.7	2.4 *3.3 *3.3	1.3 1.6 2.0	9.10
Ground	Rear dozer up Rear dozer down Rear stab down 2 sets stab down Dozer and stab down			7.1 *10.4 *10.4	3.9 4.7 5.9	4.6 7.4 6.7	2.6 3.0 3.8	3.2 5.3 4.6	1.8 2.1 2.7	2.4 *3.4 *3.4	1.3 1.6 2.0			9.00
-1.5 m	Rear dozer up Rear dozer down Rear stab down 2 sets stab down Dozer and stab down			7.2 *9.9 *9.9	3.9 4.7 5.9	4.5 7.2 6.7	2.5 3.0 3.8				2.6 *3.8 *3.8	1.4 1.7 2.2		8.58
-3.0 m	Rear dozer up Rear dozer down Rear stab down 2 sets stab down Dozer and stab down	*11.7 *11.7 *11.7	8.0 9.7 *11.7	7.3 *8.6 *8.6	4.1 4.9 6.1	4.7 *6.1 *6.1	2.6 3.1 3.9							

Stick
2.5 m

Bucket
0.9 m³

Stick 2.5 m	Undercarriage configuration	3.0 m			4.5 m			6.0 m			7.5 m			m
4.5 m	Rear dozer up Rear dozer down Rear stab down 2 sets stab down Dozer and stab down							*5.1 *5.1 *5.1	3.2 3.7 4.5	3.6 *4.6 *4.6	2.1 2.5 3.0			
3.0 m	Rear dozer up Rear dozer down Rear stab down 2 sets stab down Dozer and stab down			*8.1 *8.1 *8.1	4.7 5.5 6.8	5.1 *6.0 *6.0	3.0 3.5 4.3	3.5 *5.0 *5.0	2.0 2.4 2.9	*1.4 *1.4 *1.4	1.3 *1.4 *1.4			9.45
1.5 m	Rear dozer up Rear dozer down Rear stab down 2 sets stab down Dozer and stab down			7.5 *9.7 *9.7	4.2 5.0 6.3	4.8 *6.8 *6.8	2.8 3.3 4.0	3.3 *5.4 *5.4	1.9 2.3 2.8	*1.5 *1.5 *1.5	1.2 *1.5 *1.5			9.65
Ground	Rear dozer up Rear dozer down Rear stab down 2 sets stab down Dozer and stab down			7.2 *10.4 *10.4	4.0 4.8 6.0	4.6 *7.4 6.8	2.6 3.1 3.9	3.3 5.3 4.7	1.8 2.2 2.7	*1.6 *1.6 *1.6	1.2 1.5 *1.6			9.56
-1.5 m	Rear dozer up Rear dozer down Rear stab down 2 sets stab down Dozer and stab down			7.2 *10.3 *10.3	3.9 4.7 6.0	4.6 *7.4 6.7	2.5 3.0 3.8	3.2 5.3 4.7	1.8 2.2 2.7	*1.7 *1.7 *1.7	1.3 1.6 *1.7			
-3.0 m	Rear dozer up Rear dozer down Rear stab down 2 sets stab down Dozer and stab down	*13.4 *13.4 *13.4	7.8 9.5 12.3	7.3 *9.4 *9.4	4.0 4.8 6.1	4.6 *6.8 *6.8	2.6 3.1 3.9				*2.1 *2.1 *2.1	1.5 1.8 *2.1		8.44
-4.5 m	Rear dozer up Rear dozer down Rear stab down 2 sets stab down Dozer and stab down			*7.1 *7.1 *7.1	4.3 5.1 6.3									

	Undercarriage configuration
6.0 m	Rear dozer up Rear dozer down Rear stab down 2 sets stab down Dozer and stab down
4.5 m	Rear dozer up Rear dozer down Rear stab down 2 sets stab down Dozer and stab down
3.0 m	Rear dozer up Rear dozer down Rear stab down 2 sets stab down Dozer and stab down
1.5 m	Rear dozer up Rear dozer down Rear stab down 2 sets stab down Dozer and stab down
Ground	Rear dozer up Rear dozer down Rear stab down 2 sets stab down Dozer and stab down
-1.5 m	Rear dozer up Rear dozer down Rear stab down 2 sets stab down Dozer and stab down
-3.0 m	Rear dozer up Rear dozer down Rear stab down 2 sets stab down Dozer and stab down
-4.5 m	Rear dozer up Rear dozer down Rear stab down 2 sets stab down Dozer and stab down

	Undercarriage configuration
6.0 m	Rear dozer up Rear dozer down Rear stab down 2 sets stab down Dozer and stab down
4.5 m	Rear dozer up Rear dozer down Rear stab down 2 sets stab down Dozer and stab down
3.0 m	Rear dozer up Rear dozer down Rear stab down 2 sets stab down Dozer and stab down
1.5 m	Rear dozer up Rear dozer down Rear stab down 2 sets stab down Dozer and stab down
Ground	Rear dozer up Rear dozer down Rear stab down 2 sets stab down Dozer and stab down
-1.5 m	Rear dozer up Rear dozer down Rear stab down 2 sets stab down Dozer and stab down
-3.0 m	Rear dozer up Rear dozer down Rear stab down 2 sets stab down Dozer and stab down
-4.5 m	Rear dozer up Rear dozer down Rear stab down 2 sets stab down Dozer and stab down

Lift capacities**

with hydraulically adjustable boom – 5.41 m

Stick
1.9 m

Bucket
1.05 m³

Stick 1.9 m	Undercarriage configuration	3.0 m			4.5 m			6.0 m			7.5 m			8.65 m		
6.0 m	Rear dozer up Rear dozer down Rear stab down 2 sets stab down Dozer and stab down							*4.7	*4.7	*4.7						
4.5 m	Rear dozer up Rear dozer down Rear stab down 2 sets stab down Dozer and stab down				*6.2	*6.2	*6.2	5.3	*5.2	*5.2						
3.0 m	Rear dozer up Rear dozer down Rear stab down 2 sets stab down Dozer and stab down				*7.5	*7.5	*7.5	5.1	5.2	*6.0	3.4	*5.1	1.9	2.8	1.5	8.65
1.5 m	Rear dozer up Rear dozer down Rear stab down 2 sets stab down Dozer and stab down				7.9	*9.3	*9.3	5.0	5.1	*6.8	3.2	3.4	1.9	2.6	1.4	8.87
Ground	Rear dozer up Rear dozer down Rear stab down 2 sets stab down Dozer and stab down	*14.8	*14.8	*14.8	8.1	*10.4	*10.4	4.9	5.2	*7.3	3.0	3.3	1.8	2.6	1.8	8.77
-1.5 m	Rear dozer up Rear dozer down Rear stab down 2 sets stab down Dozer and stab down	16.6	*17.4	*17.4	8.2	*10.6	*10.6	4.7	4.9	*7.6	2.8			2.8	1.5	8.34
-3.0 m	Rear dozer up Rear dozer down Rear stab down 2 sets stab down Dozer and stab down	17.3	*18.1	*18.1	8.0	*10.9	*10.9	4.6	4.8	*6.2	2.7					

Stick	Undercarriage configuration	Stick
6.0 m	Rear dozer up Rear dozer down Rear stab down 2 sets stab down Dozer and stab down	
4.5 m	Rear dozer up Rear dozer down Rear stab down 2 sets stab down Dozer and stab down	
3.0 m	Rear dozer up Rear dozer down Rear stab down 2 sets stab down Dozer and stab down	
1.5 m	Rear dozer up Rear dozer down Rear stab down 2 sets stab down Dozer and stab down	
Ground	Rear dozer up Rear dozer down Rear stab down 2 sets stab down Dozer and stab down	
-1.5 m	Rear dozer up Rear dozer down Rear stab down 2 sets stab down Dozer and stab down	
-3.0 m	Rear dozer up Rear dozer down Rear stab down 2 sets stab down Dozer and stab down	
-4.5 m	Rear dozer up Rear dozer down Rear stab down 2 sets stab down Dozer and stab down	

Stick
2.5 m

Bucket
0.9 m³

Stick 2.5 m	Undercarriage configuration	3.0 m			4.5 m			6.0 m			7.5 m			8.65 m		
6.0 m	Rear dozer up Rear dozer down Rear stab down 2 sets stab down Dozer and stab down							*4.2	*4.2	*4.2						
4.5 m	Rear dozer up Rear dozer down Rear stab down 2 sets stab down Dozer and stab down				*5.4	*5.4	*5.4	*5.4	*4.7	*4.7	3.4	3.6	*4.5	*4.5	2.1	
3.0 m	Rear dozer up Rear dozer down Rear stab down 2 sets stab down Dozer and stab down	*8.2	*8.2	*8.2	*7.4	*7.4	*7.4	5.1	5.2	*5.6	3.4	3.6	*4.8	*4.8	2.1	9.22
1.5 m	Rear dozer up Rear dozer down Rear stab down 2 sets stab down Dozer and stab down	*11.4	*11.4	*11.4	8.0	*9.2	*9.2	5.1	*5.2	*6.5	3.3	3.6	*5.3	*5.0	2.1	9.42
Ground	Rear dozer up Rear dozer down Rear stab down 2 sets stab down Dozer and stab down	*14.2	*14.2	*14.2	8.0	*10.3	*10.3	5.0	*5.2	*7.2	3.2	3.4	*5.5	*4.9	1.9	9.33
-1.5 m	Rear dozer up Rear dozer down Rear stab down 2 sets stab down Dozer and stab down	16.4	*17.0	*17.0	8.2	*10.5	*10.5	4.8	5.1	*7.5	3.0	3.3	5.5	4.8	1.8	8.93
-3.0 m	Rear dozer up Rear dozer down Rear stab down 2 sets stab down Dozer and stab down	17.2	*17.7	*17.7	8.1	*10.8	*10.8	4.7	4.9	*7.3	2.8				*2.2	8.17
-4.5 m	Rear dozer up Rear dozer down Rear stab down 2 sets stab down Dozer and stab down	*16.6	*16.6	*16.6												

Stick	Undercarriage configuration	Stick
6.0 m	Rear dozer up Rear dozer down Rear stab down 2 sets stab down Dozer and stab down	
4.5 m	Rear dozer up Rear dozer down Rear stab down 2 sets stab down Dozer and stab down	
3.0 m	Rear dozer up Rear dozer down Rear stab down 2 sets stab down Dozer and stab down	
1.5 m	Rear dozer up Rear dozer down Rear stab down 2 sets stab down Dozer and stab down	
Ground	Rear dozer up Rear dozer down Rear stab down 2 sets stab down Dozer and stab down	
-1.5 m	Rear dozer up Rear dozer down Rear stab down 2 sets stab down Dozer and stab down	
-3.0 m	Rear dozer up Rear dozer down Rear stab down 2 sets stab down Dozer and stab down	
-4.5 m	Rear dozer up Rear dozer down Rear stab down 2 sets stab down Dozer and stab down	

3.0 m			4.5 m			6.0 m			7.5 m						m
						*3.7	3.5	*2.2	2.2						
						*3.7	*3.7	*2.2	*2.2						
						*3.7	*3.7	*2.2	*2.2						
						*4.3	3.4	3.7	2.2						
						*4.3	3.9	*4.1	*4.1						
						*4.3	*4.3	*4.1	*4.1						
*11.2		*9.6	*6.7	*5.2	*5.2	3.4	3.7	2.2	*1.3			*1.3	9.51		
	*11.2	*11.2	*6.7	*6.0	*5.2	3.8	3.8	2.6	*1.3			*1.3			
	*11.2	*11.2	*6.7	*6.7	*5.2	4.5	4.5	3.1	*1.3			*1.3			
*11.2		*11.2	*6.7	*6.7	*5.2	5.2	5.2	3.1	*1.3			*1.3			
	*11.2	*11.2	*6.7	*6.7	*5.2	5.2	5.2	3.9	*1.3			*1.3			
*11.2		9.2	8.0	5.0	*5.1	3.3	3.6	2.1	*1.3			1.2	9.71		
	*11.2	10.8	*8.7	5.7	*6.2	3.8	3.8	2.5	*1.3			*1.3			
	*11.2	*11.2	*8.7	*6.9	*6.2	4.4	4.4	3.1	*1.3			*1.3			
*11.2		*11.2	*8.7	*8.7	*6.2	6.2	*5.1	4.6	*1.3			*1.3			
	*11.2	*11.2	*8.7	8.5	*6.2	5.5	5.5	3.9	*1.3			*1.3			
*13.7		9.2	7.9	4.9	5.1	3.2	3.5	2.0	*1.4			1.2	9.62		
	*13.7	10.7	*10.0	*5.7	*7.0	3.8	3.8	2.4	*1.4			*1.4			
	*13.7	13.1	*10.0	6.8	7.0	4.5	4.5	2.9	*1.4			*1.4			
*13.7		*13.7	*10.0	*10.0	*7.0	6.4	*5.5	4.5	*1.4			*1.4			
	*13.7	*13.7	*10.0	8.4	*7.0	5.5	*5.5	3.8	*1.4			*1.4			
16.1		9.0	8.2	4.8	5.1	3.0	3.3	1.8	*1.6			1.3	9.23		
	*16.4	10.8	*10.4	5.6	*7.4	3.5	3.5	2.2	*1.6			1.5			
	*16.4	13.5	*10.4	6.9	*7.1	4.3	4.3	2.8	*1.6			*1.6			
*16.4		*16.4	*10.4	*10.1	*7.4	6.6	*5.7	4.4	*1.6			*1.6			
	*16.4	*16.4	*10.4	8.6	*7.4	5.5	*5.7	3.6	*1.6			*1.6			
16.8		8.9	8.2	4.7	4.8	2.8			*2.0			1.5	8.51		
	*17.4	10.7	*10.7	5.5	*7.6	3.3	3.3		*2.0			1.8			
	*17.4	13.7	*10.7	6.8	7.1	4.1	4.1		*2.0			*2.0			
*17.4		*17.4	*10.7	*10.5	*7.6	6.4	6.4		*2.0			*2.0			
	*17.4	*17.4	*10.7	8.8	*7.6	5.2	5.2		*2.0			*2.0			
*17.0		8.9	7.8	4.4											
	*17.7	10.7	*9.8	5.5											
	*17.7	13.7	*9.8	6.5											
*17.7		*17.7	*9.8	*9.8											
	*17.7	*17.7	*9.8	8.4											

Stick

2.9 m

Bucket

0.81 m³

All weights are in metric tons

** all lift capacities are with optional 600 kg additional counterweight and optional heavy lift hydraulic circuit.

3.0 m			4.5 m			6.0 m			7.5 m			9.0 m						m
									*2.8	2.4	*1.0							
									*2.8	2.8	*1.0							
									*2.8	*2.8	*1.0							
									*2.8	*2.8	*1.0							
									*3.1	2.4	*2.4	1.5	*0.7	*0.7		10.38		
									*3.1	2.8	*2.4	1.8	*0.7	*0.7				
									*3.1	*3.1	*2.4	2.3	*0.7	*0.7				
									*3.1	*3.1	*2.4	2.4	*0.7	*0.7				
									*3.1	*3.1	*2.4	2.4	*0.7	*0.7				
						*4.0	3.4	*3.7	2.3	2.7		1.5	*0.7	*0.7		10.81		
						*4.0	3.9	*3.7	2.7	3.2	*3.1	1.8	*0.7	*0.7				
						*4.0	*4.0	*3.7	3.2	3.2	*3.1	2.3	*0.7	*0.7				
						*4.0	*4.0	*3.7	*3.7	*3.1	*3.1	2.9	*0.7	*0.7				
						*4.0	*4.0	*3.7	*3.7	*3.1	*3.1	2.9	*0.7	*0.7				
*11.7		9.4	*6.9	5.1	5.2	3.2	3.6	2.3	2.6	2.6		1.5	*0.7	*0.7		10.97		
	*11.7	10.9	*6.9	*6.9	*5.2	*3.7	*3.7	*4.3	2.6	3.7	*3.7	1.8	*0.7	*0.7				
	*11.7	*11.7	*6.9	*6.9	*5.2	4.5	4.5	*4.3	*3.1	3.7	*3.7	2.2	*0.7	*0.7				
*11.7		*11.7	*6.9	*6.9	*5.2	5.2	5.2	*4.3	*4.3	*3.7	*3.7	3.4	*0.7	*0.7				
	*11.7	*11.7	*6.9	*6.9	*5.2	5.2	5.2	*4.3	3.9	*3.7	*3.7	2.8	*0.7	*0.7				
*12.5		9.1	7.8	4.9	5.1	3.2	3.6	2.3	2.5	2.5		1.4	*0.8	*0.8		10.90		
	*12.5	10.6	*8.8	*5.6	*6.3	3.7	3.7	*5.0	2.7	3.7	*3.9	1.7	*0.8	*0.8				
	*12.5	*12.5	*8.8	6.8	*6.3	4.4	4.4	4.9	3.1	3.6	*3.6	2.1	*0.8	*0.8				
*12.5		*12.5	*8.8	*8.8	*6.3	6.3	6.3	*5.0	*4.5	*3.9	*3.9	3.3	*0.8	*0.8				
	*12.5	*12.5	*8.8	8.3	*6.3	5.4	5.4	*5.0	3.8	*3.9	*3.9	2.7	*0.8	*0.8				
*14.0		9.0	7.9	5.0	5.0	3.2	3.5	2.1	2.4	2.4		1.3	*0.9	*0.9		10.57		
	*14.0	10.6	*10.0	5.7	*7.0	3.7	3.7	5.4	2.5	3.0	*3.1	1.6	*0.9	*0.9				
	*14.0	13.1	*10.0	6.4	6.9	4.4	4.4	4.9	3.0	3.0	*3.1	2.0	*0.9	*0.9				
*14.0		*14.0	*10.0	9.9	*7.0	6.3	6.3	5.4	4.5	*3.1	*3.1	3.1	*0.9	*0.9				
	*14.0	*14.0	*10.0	8.4	*7.0	5.4	5.4	3.8	*3.1	*3.1	*3.1	2.6	*0.9	*0.9				
16.1		8.9	*8.0	4.7	5.1	3.0	3.4	1.9					*1.1	1.1		9.96		
	*16.3	10.7	*10.3	5.5	*7.3	3.5	3.5	5.4	*2.3	4.8		2.8	*1.1	*1.1				
	*16.3	*13.6	*10.3	6.8	7.0	4.3	4.3	4.8	2.8	4.4		4.4	*1.1	*1.1				
*16.3		*16.3	*10.3	10.1	*7.3	6.5	6.5	5.6	4.4	3.7		3.7	*1.1	*1.1				
	*16.3	*16.3	*10.3	*8.6	*7.3	5.5	5.5	5.6	3.7				*1.1	*1.1				
*16.8		8.8	8.1	4.6	4.8	2.7	2.9	1.8					*1.4	1.3		9.01		
	*17.4	10.6	*10.6	5.5	*7.5	3.3	3.3	*2.9	2.1	2.7		2.7	*1.4	*1.4				
	*17.4	13.6	*10.6	6.8	7.0	4.1	4.1	*2.9	2.7	2.7		2.7	*1.4	*1.4				
*17.4		*17.4	*10.6	10.5	*7.5	6.3	6.3	*2.9	2.9	2.9		2.9	*1.4	*1.4				
	*17.4	*17.4	*10.6	8.7	*7.5	5.2	5.2	*2.9	2.9	2.9		2.9	*1.4	*1.4				

Stick

4.2 m

Bucket

0.55 m³



Load Point Height



Load Radius Over Front



Load Radius Over Rear



Load Radius Over Side



Load at Maximum Reach

* Limited by hydraulic rather than tipping load. The above loads are in compliance with hydraulic excavator lift capacity ratings standard ISO 10567, they do not exceed 87% of hydraulic lifting capacity or 75% of tipping capacity. Weight of all lifting accessories must be deducted from the above lifting capacities.

Standard equipment

The M320 is a worldwide model from Caterpillar. To provide you with the optimum configuration for your jobs, standard and optional equipment may vary. Please ask your Cat dealer for the latest equipment list for your country.

Adjustable pilot operated joystick type lever controls	Roading lights including headlights, taillights and turning lights	Lockable oscillating front axle
Alternator, 55-amp.	Suspension seat with: adjustable armrests, lumbar support and retractable seat belt	Power mode selector, economy and standard
Automatic engine speed control (AEC)	Warning horn	One-piece drive-shaft
Batteries, 2 Caterpillar	Cat 3116 T diesel engine, emission controlled, 100 kW at 2300 rpm	Openable two piece front windshield and openable skylight
Cab with:	24 Volt electric starting	Parking brake
Ash tray and lighter	2950 m altitude capacity	Prepared for optional pin-on dozer blade and/or outriggers for front and/or rear installation
Bottle holder	Downshift inhibitor	Positive filtered ventilation, 3 speed
Coat hook	Dual tires 11.00-20	Rearview mirror, left and right
Cooler box behind operators seat	Electronic Power Control Unit with backup system	Steering column, tiltable
Floor mat	Fully hydraulic braking system	Swing brake, automatic
Glass, tempered and tinted, EC approved, pressurized and sound suppressed	Full hydraulic steering with emergency steering capability	Variable displacement, load sensing hydraulic system
Heater and defroster	Hydraulic maximum speed limiter	Wide steps on both sides
Hydraulic lock, left side console activated	Hydrostatic drive 2 speed, 4 wheel drive with on-the-go shifting	Wiper and washer
Interior lighting		
Literature compartment		

Optional equipment

Additional counterweight, 400 kg	Check valves	Radio (includes Radio Mounting Kit)
Air conditioner	Boom cylinders	Refuelling pump, electric
Air horn	Stick cylinder	Rotating beacon
Air suspension seat	VA cylinder	Spacer rings, rubber, for use between dual tires
Alarm, back-up	Clamshell restraint	Sticks
Anti-drift valve	Dozer blade, front or rear mounted	1900 mm
For VA boom cylinder	Guards	2500 mm
For stick cylinder	Cab roof (FOPS)	2900 mm
For bucket cylinder	Front window	4200 mm
Auxiliary hydraulic circuits (AHC):	Vandalism protection	3400 mm material handling
Medium pressure circuit for booms and sticks	Headrest for driver's seat	Sound suppression screen
High pressure circuit for booms and sticks	Heavy lift arrangement	Sun blinds
Hammer circuit for booms and sticks	Lights	For polycarbonate skylight
Biodegradable hydraulic oil	Warning, stick mounted	For rear windscreen
Booms	Working for all booms	For right side windscreen
One piece boom	Working, front, cab mounted (2x)	Supplemental steering
Hydraulically adjustable (VA)	Working, rear, cab mounted (1x)	Tilting device (for ditch cleaning buckets only)
Buckets	Outriggers, pin-on, individually controlled	Tires
Bucket linkage	1 set, front or rear mounted	Tip groups
With diverter valve	2 sets, front and rear mounted	Tool box, left and/or right undercarriage-mounted
Without diverter valve	Overload warning device	Travel speed lock
Cab, deluxe (openable side window)	Rain protective shade for front windscreen	Two-piece drive-shaft
Cab riser, 1.2 m, fixed	Radio Mounting Kit with loudspeakers and antenna (does not include radio)	Wiper and washer for lower front windscreen

Cat '5-Star Customer Service'

Purchase a Cat M320. You know it's 'equipped' with something unique and dependable – Cat '5-Star Customer Service' as delivered by your Cat dealer.

Cat '5-Star Customer Service' means peace of mind from the minute you contact your Cat dealer. By building a partnership with your Cat dealer, you can focus on your business instead of your equipment. Cat '5-Star Customer Service' brings together all the products, services and people from Caterpillar and the Cat dealer network and puts them firmly behind you. Count on them to help you maintain your competitive edge.

Cat '5-Star Customer Service' includes Equipment Management Services to help you make a better business decision. We'll assist you in selecting the right Cat equipment to suit your need, to optimize productivity. And we'll help you make smarter decisions, assist you with machine selection, purchasing or renting options, financing, and projected owning and operating costs.

Maintenance Services that enable you to maximize machine availability and performance. Every Cat dealer has a wide choice of maintenance products and services to make sure your equipment achieves maximum performance for the lowest possible cost.

Predictive Services to anticipate problems. By anticipating potential problems and preventing unscheduled repairs, Cat Predictive Services make sure that your equipment is always up and ready to run – because maximizing uptime means maximum earning capacity.



Reconditioning Services for a wider choice of repair alternatives.

Caterpillar factory-reconditioned parts and components get your equipment back on the job in the minimum of time and with lower repair costs, contributing to reduced operating costs and a more efficient operation.

Off-the shelf availability of genuine Cat parts. Genuine parts, together with highly experienced, Cat-trained specialists make sure every repair is right first time and your machine is back earning its keep in the shortest possible time.



"Cat 5-Star Customer Service is our commitment to provide you with the best equipment and services for the most cost effective solutions in your business."

Caterpillar and Cat dealers

M320 Wheel Excavator

HEHH2185-1 (04/2000) hr

Featured photos of machines may not always include standard equipment.
See your Caterpillar Dealer for available options.
Materials and specifications are subject to change without notice.

www.CAT.com

© 2000 Caterpillar

CATERPILLAR[®]