

# M316D

Wheel Excavator



## Engine

Engine Model	Cat <sup>®</sup> C6.6 ACERT™	
Net Power	118 kW	158 hp
• Maximum power at 1,800 rpm		

## Weights

Operating Weight	17 600 kg (38,800 lb) to 19 800 kg (43,651 lb)	
------------------	---	--

## Transmission

Maximum Travel Speed	37 km/h	23 mph
----------------------	---------	--------

# M316D Wheel Excavator

*The D Series incorporates innovations for improved performance and versatility.*

---

## Engine

- ✓ Caterpillar's exclusive ACERT™ Technology surpasses the most stringent emissions requirements in the construction industry. The U.S. EPA Tier 3 compliant C6.6 offers increased performance and reliability while reducing fuel consumption and sound levels. **pg. 4**

---

## Hydraulics

- ✓ The state of the art load-sensing hydraulic system combined with a separate dedicated swing pump provides fast cycle times, increased lift capacity and high bucket and stick forces. This combination maximizes your productivity in any job. **pg. 5**

---

## Operator Comfort

- ✓ The totally redesigned operator station maximizes comfort while increasing safety. The available auto-weight adjusted air-suspension seat with heated and cooled ventilated cushions improves operator comfort. Safety is enhanced by the new color monitor and optional rear-mounted camera. **pg. 6**

---

## Versatility

Caterpillar offers a wide variety of factory-installed attachments that enhance performance and job site management. **pg. 11**

---

## Serviceability

- ✓ For increased safety, all daily maintenance points are accessible from ground level. A centralized greasing system allows lubrication of critical points. **pg. 12**

*Increased lifting capacity, improved cycle times and ease of operation lead to increased productivity and lower operating costs.*



---

### Undercarriage

Various undercarriage configurations are available to provide the best solution for your work environment; these configurations can include a dozer blade and/or outriggers depending on your needs. **pg. 8**

---

### Booms and Sticks

- ✓ Caterpillar® excavator booms and sticks are built for performance and long service life. The box section design provides the strength needed for even the toughest applications. Multiple boom and stick options allow you to pick the best match for your job. **pg. 9**

---

### Work Tools

The combination of Caterpillar machines and work tools provide a total solution for any application. A variety of couplers, buckets, hammers, grapples, shears, multi-processors to name a few are offered to optimize your machine's versatility. **pg. 10**

---

### Environmentally Responsible Design

- ✓ Helping to protect our environment, the engine has low operator and spectator sound levels, longer filter change intervals and is more fuel-efficient. **pg. 14**

---

### Complete Customer Support

Your Cat® dealer offers a wide range of services that can be set up under a customer agreement when you purchase your equipment. Your dealer will help you choose a plan that can cover everything from machine and attachment selection to replacement. **pg. 15**



✓ *New Feature*

## Engine

*Built for power, reliability, low maintenance, excellent fuel economy and low emissions.*



**Powerful Performance.** The Cat® C6.6 with ACERT™ Technology introduces a series of evolutionary, incremental improvements that provide breakthrough engine performance. The building blocks of ACERT Technology are fuel delivery, air management and electronic control. ACERT Technology optimizes engine performance while meeting U.S. EPA Tier 3 engine emission regulations. The Cat C6.6 engine in the M316D delivers a maximum gross power of 124 kW (166 hp) at a rated speed of 1,800 rpm. This is 15% more horsepower as compared to the 3056E in the M316C.

**Low Fuel Consumption.** The C6.6 is electronically controlled and uses the new Cat Common Rail Fuel System and fuel pump. This combination provides outstanding fuel consumption during both production and travel. When the system recognizes roading application the engine adjusts to the most efficient system operating point to save fuel without compromising road performance.

**Low Noise, Low Vibration.** The Cat C6.6 design improves operator comfort by reducing sound and vibration.

**Cooling System.** An electronically controlled, hydraulic motor drives a variable speed on-demand fan for engine coolant and hydraulic oil. The optimum fan speed is determined based on coolant and hydraulic oil temperature resulting in reduced fuel consumption and lower sound levels. The electronic engine control continuously compensates for the varying fan load, providing consistent net power, regardless of operating conditions.

**One-Touch Low Idle Control.**

The two-stage, one-touch Automatic Engine Speed Control reduces engine speed if no operation is performed, maximizing fuel efficiency and reducing sound levels.

**Waste Handling Package.** The Waste Handling Package has been specifically developed for Cat Wheel Excavators working in waste transfer stations or other extremely dusty applications. This option features the following:

- An automatic, hydraulic reversible fan that reverses airflow after a set interval, manually adjustable between 5 and 60 minutes with a switch located inside the cab.
- A special dense wire mesh cooling system hood further reduces radiator clogging.
- Two cyclone filters provide clean filtered air to the engine compartment, air cleaner, aftercooler and air conditioner condenser.

## Hydraulics

*Fast cycle times, increased lift capacity, and high bucket and stick forces combine to maximize your productivity in any job.*

**Dedicated Swing Pump.** A dedicated variable displacement piston pump and fixed displacement piston motor power the swing mechanism. This closed hydraulic circuit maximizes swing performance without reducing power to the other hydraulic functions, resulting in smoother combined movements.

**Heavy Lift Mode.** This mode maximizes lifting performance by boosting the lifting capability of the excavator by 7 percent. Heavy loads can be easily moved in the full working range of the machine, maintaining excellent stability.

**Adjustable Hydraulic Sensitivity.** This function allows the operator to adjust the aggressiveness of the machine according to the application. For precision work, one of four different levels of aggressiveness can be pre-selected.



### Proportional Auxiliary Hydraulics.

Versatility of the hydraulic system can be expanded to utilize a wide variety of hydraulic work tools using multiple valve options.

- The Multi-Combined Valve is the core of the Tool Control System, allowing the operator to select up to ten pre-programmed work tools from the monitor. These preset hydraulic parameters support either one-way or two-way flow. The joystick sliding switches allow modulated control of the work tool.



- A dedicated Hammer circuit is the best option for tools that require one-way flow only, and do not require the flexibility provided by the Multi-Combined Valve.
- The Medium Pressure Function Valve provides proportional flow that is ideal for tilting buckets or rotating tools.
- A new feature for the D-Series Wheel Excavators is the optional second High Pressure valve. In combination with the Multi-Combined Valve, it provides the possibility to operate the machine with work tools or in applications requiring a third auxiliary hydraulic function, such as a tilting/rotating quick coupler.

**Stick Regeneration Circuit.** The stick regeneration circuit increases efficiency and helps increase controllability for higher productivity and lower operating costs.

**Quick Coupler.** The machine can be optionally equipped with a dedicated hydraulic circuit to operate hydraulic quick couplers.

**Hydraulic Snubbers.** Caterpillar integrates its cylinder snubber technology into all Wheel Excavator boom, stick and bucket cylinders. These snubbers help cushion shocks, reduce sound and increase cylinder life.

**Caterpillar XT™-6 ES Hoses.** Premium quality rubber, precision 4-ply wire reinforcement and exclusive reusable couplings are all unique features that deliver top performance and long life.

## Operator Comfort

*The interior layout maximizes operator space, provides exceptional comfort and reduces operator fatigue.*



**Interior Operator Station.** Improved visibility and ergonomics are some of the many new features of the D-Series Wheel Excavators. The pressurized operator station provides maximum space and is designed for simplicity and functionality. Frequently used switches are centralized and are situated on the right-hand switch console. The left-hand seat console controls dozer blade and/or outriggers, and is tiltable for easy access to the cab. The fully automatic climate control adjusts temperature and air flow for exceptional operator comfort. Other comfort features include a cigar lighter, ashtray, drink/bottle holder, magazine rack and integrated mobile phone holder.

**Cab Construction.** The exterior design uses thick steel tubing along the bottom perimeter of the cab, improving the resistance to fatigue and vibration. This design allows the falling object guards to be bolted directly to the cab. The cab shell is attached to the frame with rubber mounts that limit vibration and sound transmitted from the frame, substantially reducing interior noise levels.



**Viewing Area.** To maximize visibility, all glass is affixed directly to the cab, eliminating the use of window frames. Choice of fixed or easy-to-open split front windshield meets operator preference and application conditions.

- The 50/50 split front windshield allows both upper and lower portions to be stored in an overhead position and features the one-touch action release system.
- The 70/30 split front windshield stores the upper portion above the operator. The lower front windshield features a rounded design to maximize downward visibility and improves wiper coverage. Also features the one-touch action release system.
- The fixed front windshield comes with high impact resistant laminated glass.
- A unique large skylight without cross bar provides superb upward visibility. The retractable sunscreen blocks direct sunlight.



**Monitor.** The new compact color monitor displays information in local language that is easy to read and understanding. Functions include:

- 5 programmable “Quick Access” buttons for one-touch selection of favorite functions.
- Filter and oil change warnings are displayed when the number of hours reaches the maintenance interval.
- Tool select function allows the operator to select up to 10 pre-defined hydraulic work tools.

– Adjustable braking characteristics enable the operator to select three levels of travel motor retarder aggressiveness when releasing the travel pedal.

– Provides a rear camera view that is activated through the monitor menu. The optional camera is mounted on the counterweight.

**New Deluxe Seat.** The new optional deluxe seat, equipped with an active seat climate system, improves operator comfort. Cooled air flows through the seat cushions to reduce body perspiration. On cold days, a two-step seat heater keeps the operator warm and comfortable. The fully adjustable seat with adjustable lumbar support automatically adjusts to the driver’s weight providing a more relaxed and comfortable environment.

**Heated Mirrors.** Another new feature is electrically heated mirrors, increasing safety and visibility in cold conditions.

**Wipers.** The parallel wiper system maximizes visibility in poor weather conditions. The wiper virtually covers the entire front windshield, cleaning the operator’s immediate line of sight.

**Lunch Box.** A large, cooled storage compartment is located behind the operator’s seat. The compartment provides sufficient room to store items such as a lunch box. An optional cover secures the contents during machine operation.

**Foot Pedals.** Two-way pedals for travel and auxiliary circuits provide increased floor space, reducing the need to change positions. The foot pedal for auxiliary high-pressure circuit can be locked in the off position and used as a footrest for greater operator comfort.

## Undercarriage

*Undercarriage and axle design provides maximum strength, flexibility and mobility on wheels.*



### **New Increased Travel Speed.**

The maximum travel speed for the D-Series Wheel Excavators has been increased from 34 km/h (21 mph) to 37 km/h (23 mph), reducing travel time between sites and increasing productivity.

### **Heavy-Duty Axles and Stabilizers.**

The D-Series Wheel Excavator undercarriage with pin on/bolt on design provides excellent flexibility, rigidity and long life. Effective hydraulic line routing, transmission protection and heavy-duty axles make the undercarriage perfect for wheel excavator applications. The front axle offers wide oscillating and steering angles. The transmission is mounted directly on the rear axle for protection and optimum ground clearance.

**Advanced Disc Brake System.** The disc brake system acts directly on the hub instead of the drive shaft to avoid planetary gear backlash. This solution eliminates the rocking effect associated with working free on wheels. The axle design lowers maintenance and lifetime costs. Oil change intervals are at 2,000 working hours, further reducing owner and operator costs.



**Drive Line Concept.** The rear mounted transmission and robust drive line design, delivers excellent ground clearance for all off-road applications.

**Fenders.** The optional fenders provide excellent coverage of the front and rear tires, protecting the machine from mud and dirt. Water cannot splash up on the wind screen or cooler. The fenders further protect the machine from stones and debris being thrown up by the tires, providing additional safety for the machine, other vehicles and personnel working close to the excavator.

**Adjustable Travel Alarm.** An adjustable travel alarm is available to warn people when the machine is moving. Three settings can be selected through the monitor.

- Auto mode – alarm will stop sounding immediately when the machine is no longer traveling, or has been sounding for an uninterrupted 10-second interval.
- Standard mode – alarm operates constantly during moving, with only manual cancellation.
- Off mode – Travel Alarm is disabled.



## Booms and Sticks

*Designed for maximum flexibility to keep production high on all jobs.*



### *Industrial Stick*

**Sticks.** Four different stick lengths are offered to match different application requirements:

- Short stick (2.1 m/6 ft 11 in) for maximum breakout force and lifting capability.
- Medium stick (2.4 m/7 ft 10 in) for greater crowd force and lift capacity.
- Long stick (2.6 m/8 ft 6 in) for greater depth and reach requirements.
- Industrial stick (3.1 m/10 ft 2 in) for use with free-swinging grapples in material handling and industrial applications.

**Design.** Booms and sticks are welded, box section structures with thick, multi-plate fabrications in high stress areas, for rugged performance and long service life.

**Flexibility.** The choice of three booms and four sticks provides the right balance of reach and digging forces for all applications.



### **Variable Adjustable (VA) Boom.**

The VA boom offers improved right side visibility and machine roading balance. When working in tight quarters or lifting heavy loads, the VA boom offers the best flexibility.

**One-Piece Boom.** The one-piece boom fits best for all standard applications such as truck loading and digging. A unique straight section in the curve of the side plate reduces stress flow and helps increase boom life.

## Work Tools

*A wide variety of Work Tools help optimize machine performance. Purpose designed and built to Caterpillar's high durability standards.*



**Work Tools.** Caterpillar work tools are designed to function as an integral part of your excavator and to provide the best possible performance in your particular application. All work tools are performance-matched to Cat machines.

**Quick Couplers.** Quick Couplers enable the operator to simply release one work tool and connect to another, making your hydraulic excavator highly versatile. Productivity also increases, as a carrier no longer needs to be idle between jobs. Caterpillar offers hydraulic and spindle quick coupler versions.

**Buckets.** Caterpillar offers a wide range of specialized buckets, each designed and tested to function as an integral part of your excavator. Buckets feature the new Caterpillar K Series™ Ground Engaging Tools.

**Hammers.** Cat hammer series deliver very high blow rates, increasing the productivity of your carriers in demolition and construction applications. Wide oil flow acceptance ranges make the Caterpillar hammers suitable for a wide range of carriers and provide a system solution from one safe source.

**Orange Peel Grapples.** The Orange Peel Grapple is constructed of high-strength, wear-resistant steel, with a low and compact design that makes it ideal for dump clearance. There are several choices of tine and shell versions.

**Multi-Grapples.** The Multi-Grapple with unlimited left and right rotation is the ideal tool for stripping, sorting, handling and loading. The powerful closing force of the grab shells combined with fast opening/closing time ensures rapid cycle time which translates to more tons per hour.

**Multi-Processors.** Thanks to its single basic housing design, the Multi-Processor series of hydraulic demolition equipment makes it possible to use a range of jaw sets that can handle any demolition job. The Multi-Processor is the most versatile demolition tool on the market.

### **Vibratory Plate Compactors.**

Cat compactors are performance-matched to Cat machines, and integrate perfectly with the Cat hammer line – brackets and hydraulic kits are fully interchangeable between hammers and compactors.

**Shears.** Cat shears provide superior and effective scrap processing, and are highly productive in demolition environments. Shears are compatible with a matching Cat excavator, and bolt-on brackets are available for either stick or boom-mounted options.

## Versatility

*A wide variety of optional factory-installed attachments are available to enhance performance and improve job site management.*

**Joystick Steering.** The unique joystick steering option enables an operator to reposition the machine while traveling in first gear by the use of the slider switch on the right joystick. This enables the operator to keep both hands on the joysticks while simultaneously moving the implements and traveling. The operator can do more precise work faster with increased safety around the machine.

**Ride Control.** New for the D Series, the ride control system improves operator comfort and allows the machine to travel faster over rough terrain with improved ride quality for the operator. The ride control system features accumulators acting as shock absorbers to dampen the front part motion. Ride control can be activated through a button located on the soft switch panel in the cab.

**Tool Control.** The integrated Tool Control system allows the operator to select up to 10 pre-set combinations. This eliminates the need to re-set the hydraulic parameters each time a tool is changed. Individual flow and pressure can be programmed easily as well as one-way/two-way hydraulic functions. Each of the ten-programmed tools can even be given a specific name. The unique Cat proportional sliding switches and optional auxiliary pedal provide modulation to the tool to make precision work easy.



**Control Settings.** There are 2 selectable control settings and one automatic travel setting. The new automatic travel mode is activated with a button in the right hand console. In this setting, the transmission will automatically shift up or down, depending on the speed conditions. The operator can choose the best power setting for both engine and hydraulic power versus fuel efficiency.

- Economy Mode – used for lifting, pipe setting, grading, slope finishing and precise work while reducing fuel consumption.
- Power Mode – used for normal truck loading and digging applications, trenching or hammer use.

- Travel Mode – automatically set when the travel pedal is actuated. It provides maximum speed and drawbar pull.

**Product Link.** Product Link can assist with Fleet Management to keep track of hours, location, security and product health. The machine is pre-wired to accept Product Link systems to be installed in the field. Product Link is also available as a factory installed attachment.

**Machine Security.** An optional Machine Security System is available from the factory. This system controls who can operate the machine when, and utilizes specific keys to prevent unauthorized machine use.



## Serviceability

*Simplified and easy maintenance save you time and money.*



**Ground Level Maintenance.** Caterpillar designed its D-Series Wheel Excavators with the operator and service technician in mind. Gull-wing doors, with pneumatically-assisted lift cylinders, effortlessly lift up to allow critical maintenance to be performed quickly and efficiently while maintaining operator safety.

**Extended Service Intervals.** The D-Series Wheel Excavator service and maintenance intervals have been extended to reduce machine service time, increase machine availability and reduce operating costs. Using S•O•S<sup>SM</sup> Scheduled Oil Sampling analysis, hydraulic oil change intervals can be extended up to 4000 hours. Engine coolant change intervals are 12,000 hours with Cat Extended Life Coolant.

**Self-Monitoring System with Auto-Diagnostics.** The electronic engine and machine controllers provide detailed diagnostic capability for the service technicians. The ability to store active and intermittent indicators simplifies problem diagnosis and reduces total repair time, resulting in improved machine availability and lower operating cost.

**Engine Inspection.** The engine can be accessed from both ground level and the upper structure. The longitudinal layout ensures that all daily inspection items can be accessed from ground level.



**Front Compartment.** The front compartment hood can be opened vertically, providing outstanding ground level access to the batteries, air-to-air after cooler, air conditioner condenser and the air cleaner filter.



**Easy to Clean Coolers.** Flat fins on all coolers reduce clogging, making it easier to remove debris. The main cooling fan and air conditioner condenser are both hinged for easier cleaning.

**Swing-out Air Conditioner Condenser.** The Air Conditioning condenser swings out horizontally to allow complete cleaning on both sides as well as excellent access to the air-to-air after cooler.

**Air Filter.** Caterpillar air filters eliminate the use of service tools, reducing maintenance time. The air filter features a double-element construction with wall flow filtration in the main element and built-in mini-cyclone precleaners for superior cleaning efficiency. The air filters are constantly monitored for optimum performance. If airflow becomes restricted, a warning is displayed by the way of the in-cab monitor.

**Capsule Filter.** The hydraulic return filter, a capsule filter, prevents contaminants from entering the system when the hydraulic oil is changed.

**Fuel Filters.** Cat high efficiency fuel filters with a Stay-Clean Valve™ features a special media that removes more than 98 percent of particles, increasing fuel injector life. Both the primary and secondary fuel filters are located in the engine compartment and can be easily changed from ground level.



**New Auto-Lube System.** The new automatic lubrication system provides the optimal amount of grease to all the main lubrication points, including the bucket linkage. The lubrication interval can be adjusted through the monitor, and status messages for the auto-lube system are displayed.

**Scheduled Oil Sampling.** Caterpillar has specially developed S•O•S<sup>SM</sup> Oil Sampling Analysis to help ensure better performance, longer life and increased customer satisfaction. This thorough and reliable early warning system detects traces of metals, dirt and other contaminants in your engine, axle and hydraulic oil. It can predict potential trouble avoiding costly failures. Your Caterpillar dealer can give you results and specific recommendations shortly after receiving your sample.

**Engine Oil.** Caterpillar engine oil is formulated to optimize engine life and performance. The specially formulated oil is more cost effective and increases engine oil change interval to 500 hours, providing industry leading performance and savings.

**Water Separator.** The D Series is equipped with a primary fuel filter with water separator located in the engine compartment. For ease of service, the water separator can be easily accessed from ground level.

**Fuel Tank Drain.** The durable, corrosion-free tank has a remote drain located at the bottom of the upper frame to remove water and sediment. The tank drain with hose connection allows simple, spill-free fluid draining.

**Remote Greasing Blocks.** For those hard to reach locations, greasing blocks have been provided to reduce maintenance time. One block is located in the engine compartment with two grease points for the swing bearing and front-end attachment. For the undercarriage, two remote blocks provide easy access for greasing the oscillating axle and, as an option, the dozer blade.



**New LED Rear Lights.** Optional Light Emitting Diode (LED) Rear Lights replace the standard lights, for increased visibility on the job site, higher durability and longer life.

**Handrails and Steps.** Large handrails and steps assist the operator in climbing on and off the machine.



**Storage Box.** There are two toolboxes integrated in the steps of the undercarriage. Additionally, there is a waterproof storage box integrated into the upper structure steps.



**Anti-Skid Plate.** They cover the top of the steps and upper structure to help prevent slipping during maintenance. The Anti-Skid plate reduces the accumulation of mud on the upper structure, improving the cleanliness and safety.

## Environmentally Responsible Design

*The M316D helps build a better world and preserve the fragile environment.*



**Fuel Efficiency.** The D-Series Wheel Excavators are designed for outstanding performance with high fuel efficiency. This means more work done in a day, less fuel consumed and minimal impact on our environment.

**Low Exhaust Emissions.** The U.S. EPA Tier 3 compliant Cat C6.6 offers increased performance and reliability while reducing fuel consumption and sound levels.

**Quiet Operation.** Operator and spectator noise levels are extremely low as a result of the new variable speed fan and remote cooling system.

**Biodegradable Hydraulic Oil.**

The optional biodegradable hydraulic oil (HEES™) is formulated to provide excellent high-pressure and high-temperature characteristics, and is fully compatible with all hydraulic components. HEES is fully decomposed by soil or water microorganisms, providing a more environmentally-sound alternative to mineral-based oils.

**Fewer Leaks and Spills.** Lubricant fillers and drains are designed to minimize spills. Cat O-Ring Face Seals, Cat XT™ Hose and hydraulic cylinders are all designed to help prevent fluid leaks that can reduce the machine performance and cause harm to the environment.

**Longer Service Intervals.** Working closely with your Caterpillar Dealer can help extend service intervals for engine oil, hydraulic oil, axle oil and coolant. Meaning fewer required fluids and fewer disposals, all adding up to lower operating costs.

## Complete Customer Support

*Cat dealer services help you operate longer with lower costs.*

**Product Support.** You will find nearly all parts requirements at your local Caterpillar dealer parts counter. Cat dealers utilize a world-wide network to find in-stock parts to minimize your downtime. To save money use genuine Cat Reman parts. You will receive the same warranty and reliability as new products at a substantial cost savings.

**Selection.** Make detailed comparisons of the machines you are considering before you buy. How long do components last? What is the cost of preventive maintenance? Your Cat dealer can give you precise answers to these questions to make sure you operate your machines at the lowest cost.

**Purchase.** Consider the financing options available as well as day-to-day operating costs. This is also the time to look at dealer services that can be included in the cost of the machine to yield lower equipment and owning and operating costs over the long run.

**Operation.** Improving operating techniques can boost your profits. Your Cat dealer has videotapes, literature and other ideas to help you increase productivity, and Caterpillar offers certified operator training classes to help maximize the return on your machine investment.



**Maintenance.** More and more equipment buyers are planning for effective maintenance before buying equipment. Choose from your dealer's wide range of maintenance services at the time you purchase your machine. Repair option programs guarantee the cost of repairs up front. Diagnostic programs such as S•O•S<sup>SM</sup> Fluid Analysis and Technical Analysis help you avoid unscheduled repairs.

**Replacement.** Repair, rebuild or replace? Your Cat dealer can help you evaluate the cost involved so you can make the right choice.

**Services.** Customer Service is critical today in every business. That's why so many people buy Cat equipment. They know they are getting quality, reliability and performance backed-up with the best Customer Service. Your Caterpillar dealer offers a wide range of services that can be set up under a Customer Support Agreement. The dealer will help you choose a plan that can cover the whole machine including work tools, to help you getting the best out of your investment.

## Engine

Engine Model	Cat® C6.6 ACERT™	
Net Power	118 kW	158 hp
Gross Power	124 kW	166 hp
ISO 9249	118 kW	158 hp
EEC 80/1269	118 kW	158 hp
Bore	105 mm	4.13 in
Stroke	127 mm	5 in
Displacement	6.6 L	403 in <sup>3</sup>
Cylinders	6	
Maximum Torque at 1,400 rpm	785 N·m	579 lb ft

- Maximum power at 1,800 rpm

## Weights

Operating Weight	17 600 kg (38,800 lb) to 19 800 kg (43,651 lb)	
VA Boom		
Rear dozer only	17 200 kg	37,919 lb
Rear dozer, front outriggers	18 250 kg	40,234 lb
Front and rear outriggers	18 500 kg	40,785 lb
One-Piece Boom		
Rear dozer only	16 700 kg	36,817 lb
Rear dozer, front outriggers	17 750 kg	39,132 lb
Front and rear outriggers	18 000 kg	39,683 lb
Offset Boom		
Rear dozer only	17 650 kg	38,912 lb
Rear dozer, front outriggers	18 700 kg	41,226 lb
Front and rear outriggers	18 950 kg	41,778 lb
Dozer Blade	740 kg	1,700 lb
Outriggers	1030 kg	2,270 lb
Counterweight	3700 kg	8,157 lb
2.1 m (6'11") stick	470 kg	1,036 lb
2.4 m (7'10") stick	514 kg	1,133 lb
2.6 m (8'6") stick	530 kg	1,168 lb
3.1 m (10'2") Industrial stick	450 kg	992 lb

## Swing Mechanism

Swing Speed	10.5 rpm	
Swing Torque	40 kN·m	29,502 lb ft

## Cab

Cab/FOGS option	ISO 10262
-----------------	-----------

## Hydraulic System

### Maximum Pressure

Implement circuit		
normal	35 000 kPa	5,076 psi
heavy lift	37 500 kPa	5,439 psi
Travel circuit	35 000 kPa	5,076 psi
Auxiliary circuit		
high pressure	35 000 kPa	5,076 psi
medium pressure	18 500 kPa	2,683 psi
Swing mechanism	37 000 kPa	5,366 psi

### Maximum flow

Implement/travel circuit	250 L/min	66 gal/min
Auxiliary circuit		
high pressure	250 L/min	66 gal/min
medium pressure	50 L/min	13 gal/min
Swing mechanism	80 L/min	21 gal/min

## Transmission

Maximum Travel Speed	37 km/h	23 mph
1st Gear, Forward/Reverse	8 km/h	5 mph
2nd Gear, Forward/Reverse	37 km/h	23 mph
Creeper Speed (1st Gear)	3 km/h	2 mph
Creeper Speed (2nd Gear)	13 km/h	8 mph
Drawbar Pull	97 kN	21,806 lb
Maximum Gradeability	63 %	

## Service Refill Capacities

Fuel Tank Capacity	310 L	82 gal
Cooling	32 L	8.5 gal
Engine Crankcase	15 L	4 gal
Rear Axle Housing (Differential)	14 L	3.7 gal
Front Steering Axle (Differential)	10.5 L	2.8 gal
Final Drive		
Final Drive	2.5 L	.7 gal
Powershift Transmission	2.5 L	.7 gal
Hydraulic Tank	135 L	36 gal
Hydraulic System (including tank)	220 L	58 gal

## Tires

Optional	See Optional Equipment
Standard	10.00-20 dual pneumatic



## Undercarriage

Ground Clearance	370 mm	15 in
Maximum Steering Angle ±	35°	
Oscillating Axle Angle ±	9°	

### Standard Axle

Minimum Turning Radius (Outside of tire)	6.4 m	21 ft
Minimum Turning Radius (End of VA boom)	7 m	23 ft
Minimum Turning Radius (End of One-piece boom)	8.3 m	27 ft

### Wide Axle

Minimum Turning Radius (Outside of tire)	6.5 m	21 ft
Minimum Turning Radius (End of VA boom)	7.1 m	23 ft
Minimum Turning Radius (End of One-piece boom)	8.5 m	28 ft

## Sound Performance

Performance	Exterior sound power level according to 2000/14/EC is 103 db(A) Interior sound pressure level LpA is 72 db(A)
-------------	--

- When properly installed and maintained, the cab offered by Caterpillar, when tested with doors and windows closed according to ANSI/SAE J1166 OCT 98, meets OSHA and MSHA requirements for operator sound exposure limits in effect at time of manufacture.
- Hearing protection may be needed when operating with an open operator station and cab (when not properly maintained or doors/windows open) for extended periods or in noisy environment.

## Standards

Brakes	SAE J1026 APR 90
Cab/FOGS	ISO 10262

# Dimensions

All dimensions are approximate.

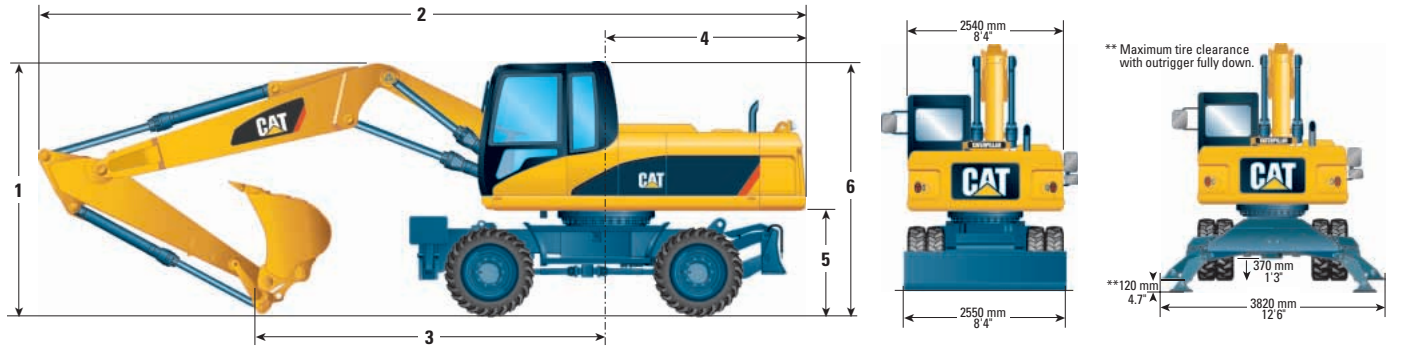

**Undercarriage with dozer only**

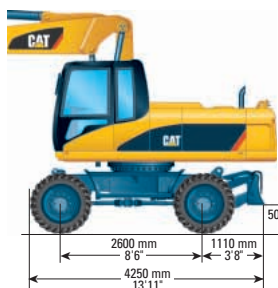

**Undercarriage with 2 sets of outriggers**

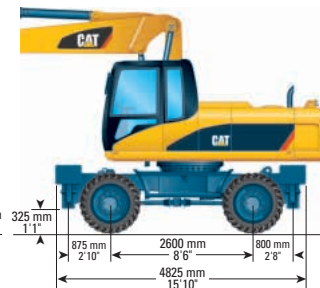

**Undercarriage with 1 set of outriggers and dozer**

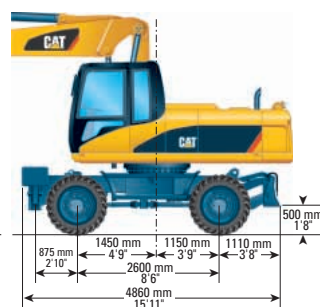

**Roading position with 2.4 m/7'10" stick**

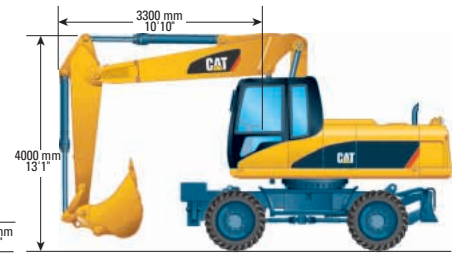

Stick Options	2.1 m (6'11")		2.4 m (7'10")		2.6 m (8'6")		Industrial Stick 3.1 m (10'2")	
	mm	ft/in	mm	ft/in	mm	ft/in	mm	ft/in
<b>1 Shipping Height</b>								
VA Boom	3170	10'5"	3170	10'5"	3170	10'5"	3330	10'11"
One-piece Boom	3170	10'5"	3170	10'5"	3170	10'5"	3330	10'11"
Offset Boom	3170	10'5"	3170	10'5"				
<b>2 Shipping Length</b>								
VA Boom	8550	28'1"	8550	28'1"	8540	28'0"	8510	27'11"
One-piece Boom	8390	27'6"	8400	27'7"	8400	27'7"	8405	27'7"
Offset Boom	8550	28'1"	8540	28'0"				
<b>3 Support Point</b>								
VA Boom	3910	12'10"	3650	11'12"	3550	11'8"	3630	11'11"
One-piece Boom	3560	11'8"	3270	10'9"	3150	10'4"	3230	10'7"
Offset Boom	4020	13'2"	3780	12'5"				
<b>4 Tail Swing Radius</b>								
VA Boom and One-piece Boom	2280	7'6"	2280	7'6"	2280	7'6"	2280	7'6"
Offset Boom	2280	7'6"	2280	7'6"				
<b>5 Counterweight Clearance</b>								
VA Boom and One-piece Boom	1280	4'2"	1280	4'2"	1280	4'2"	1280	4'2"
Offset Boom	1280	4'2"	1280	4'2"				
<b>6 Cab Height</b>								
VA Boom and One-piece Boom	3170	10'5"	3170	10'5"	3170	10'5"	3170	10'5"
Offset Boom	3170	10'5"	3170	10'5"				

Note: All dimensions are approximate and cab height is without Falling Object Guards.

# VA Boom, One-piece and Offset Boom Working Ranges

2.1 m (6'11"), 2.4 m (7'10"), 2.6 m (8'6"),  
3.1 m (10'2") Sticks

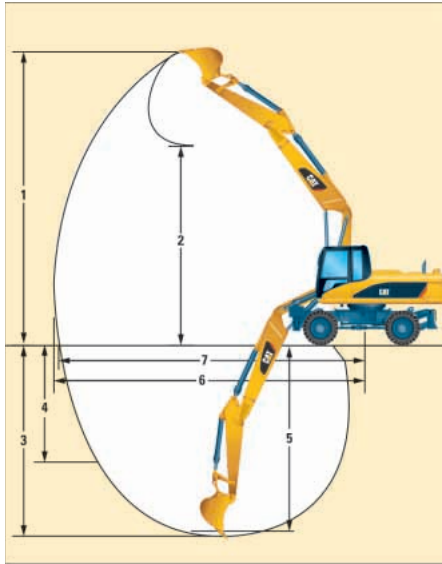

2.1 m (6'11"), 2.4 m (7'10"), 2.6 m (8'6"),  
3.1 m (10'2") Sticks

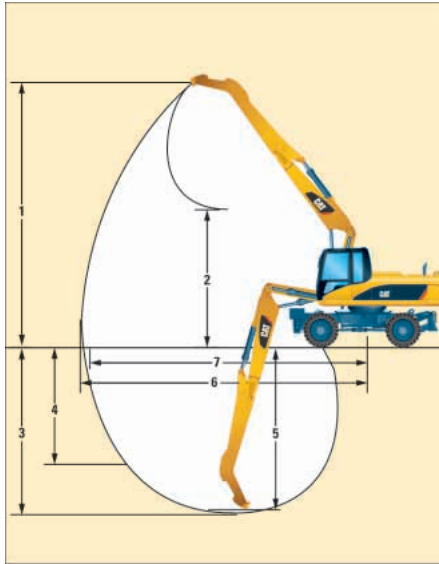

2.1 m (6'11"), 2.4 m (7'10") Sticks

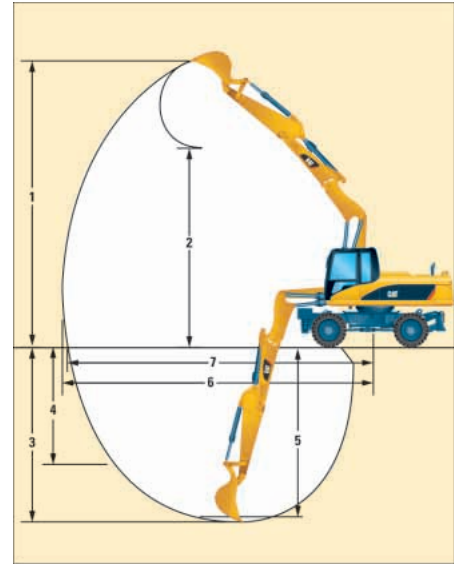

	VA Boom – 5.2 m (17'1")				One-piece Boom – 5.05 m (16'7")				Offset Boom – 5.2 m (17'1")	
	2.1 m (6'11")	2.4 m (7'10")	2.6 m (8'6")	Industrial Stick* 3.1 m (10'2")	2.1 m (6'11")	2.4 m (7'10")	2.6 m (8'6")	Industrial Stick* 3.1 m (10'2")	2.1 m (6'11")	2.4 m (7'10")
1 Digging Height	10 060 mm (32'0")	10 250 mm (33'8")	10 400 mm (34'2")	8970 mm (29'5")	9000 mm (29'7")	9090 mm (29'10")	9210 mm (30'3")	7720 mm (25'4")	9960 mm (32'8")	10 150 mm (33'4")
2 Dump Height	6970 mm (22'11")	7160 mm (23'6")	7320 mm (24'0")	3980 mm (13'1")	6020 mm (19'9")	6130 mm (20'2")	6250 mm (20'6")	3200 mm (10'6")	7150 mm (23'5")	7340 mm (24'1")
3 Digging Depth	5570 mm (18'3")	5870 mm (19'3")	6070 mm (19'11")	5030 mm (16'6")	5370 mm (17'8")	5670 mm (18'7")	5870 mm (19'3")	4820 mm (15'10")	5450 mm (17'11")	5750 mm (18'11")
4 Vertical Wall Digging Depth	3700 mm (12'2")	3900 mm (12'10")	4070 mm (13'4")	N/A	3490 mm (11'6")	3630 mm (11'11")	3800 mm (12'6")	N/A	4100 mm (13'6")	4320 mm (14'2")
5 Depth 2.5 m (8'2") Straight Clean-up	5350 mm (17'7")	5670 mm (18'7")	5880 mm (19'4")	N/A	5150 mm (16'11")	5470 mm (17'12")	5680 mm (18'8")	N/A	5200 mm (17'1")	5520 mm (18'1")
6 Reach	9100 mm (29'11")	9360 mm (30'9")	9560 mm (31'5")	8370 mm (27'6")	8900 mm (29'3")	9160 mm (30'1")	9350 mm (30'8")	8130 mm (26'8")	8970 mm (29'5")	9240 mm (30'4")
7 Reach at Ground Level	8910 mm (29'3")	9190 mm (30'2")	9380 mm (30'10")	8170 mm (26'10")	8710 mm (28'7")	8970 mm (29'5")	9170 mm (30'1")	7920 mm (25'0")	8780 mm (28'10")	9060 mm (29'9")
Bucket Forces (ISO 6015)	101 kN (22,705 lbf)	101 kN (22,705 lbf)	101 kN (22,705 lbf)	N/A	101 kN (22,705 lbf)	101 kN (22,705 lbf)	101 kN (22,705 lbf)	N/A	101 kN (22,705 lbf)	101 kN (22,705 lbf)
Stick Forces (ISO 6015)	81 kN (18,209 lbf)	74 kN (16,635 lbf)	71 kN (15,961 lbf)	N/A	81 kN (18,209 lbf)	74 kN (16,635 lbf)	71 kN (15,961 lbf)	N/A	81 kN (18,209 lbf)	74 kN (16,635 lbf)

\* Industrial Stick has no bucket linkage. All dimensions refer to stick-nose.

Values 1-7 are calculated with bucket and quick coupler with a tip radius of 1552 mm (5'1").

Breakout force values are calculated with heavy lift on (no quick coupler) and a tip radius of 1405 mm (4'7").

# Work Tools Matching Guide

When choosing between various work tool models that can be installed onto the same machine configuration, consider work tool application, productivity requirements, and durability. Refer to work tool specifications for application recommendations and productivity information.

			Variable adjustable boom 5200 mm (17'1")									One-piece boom 5050 mm (16'7")								
			Dozer lowered			2 sets of stabilizer lowered			Dozer and stabilizer lowered			Dozer lowered			2 sets of stabilizer lowered			Dozer and stabilizer lowered		
			2100	2400	2600	2100	2400	2600	2100	2400	2600	2100	2400	2600	2100	2400	2600	2100	2400	2600
<b>Without quick coupler</b>		(mm) Stick length (ft/in)	6'10"	7'10"	8'6"	6'10"	7'10"	8'6"	6'10"	7'10"	8'6"	6'10"	7'10"	8'6"	6'10"	7'10"	8'6"	6'10"	7'10"	8'6"
Hammers	H100, H115 s																			
	H120C s				×			×			×			×			×			×
Multiprocessors	MP15	CC, CR, S	×	×	×							×	×	×						
		PP, PS	×	×	×			×			×	×	×	×			×			×
360° rotatable Shears (boom mounted)	S320																			
	S325		×	×	×							×	×	×						
Sorting & Demo Grapple	G315B	D, R	×	×	×															
Compactors	CVP75																			
Orange Peel Grapples (4 tines)	GSH15	400 L (0.5 yd³)																		
		500 L (0.67 yd³)		×	×										×		×			
		600 L (0.75 yd³)	×	×	×									×	×	×				
		800 L (1.00 yd³)	×	×	×									×	×	×				

• Not all work tools are available in all areas.

360° Working Range

Over the front only

Maximum Material density 1800 kg/m³ (3,000 lb/yd³)

Maximum Material density 1200 kg/m³ (2,000 lb/yd³)

× Not Compatible

# Bucket Specifications

Contact your Caterpillar dealer for special bucket requirements.











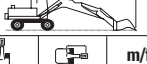



## Pin-on Buckets

Bucket Type	Width		Weight		Capacity (SAE)		No. of Teeth
	mm	in	kg	lb	m <sup>3</sup>	yd <sup>3</sup>	
General Purpose	610	24	384	847	0.34	0.45	3
	762	30	436	963	0.47	0.62	4
	914	36	489	1080	0.61	0.8	5
	991	39	569	1257	0.74	0.97	4
	1067	42	534	1179	0.78	1.02	5
	1219	48	586	1294	0.88	1.15	6
	1295	51	672	1484	1.03	1.35	5
	1397	55	704	1554	1.12	1.47	5
General Purpose Wide Tip	610	24	445	983	0.44	0.58	3
	762	30	506	1116	0.58	0.76	4
	914	36	577	1274	0.76	0.99	5
	1067	42	581	1282	0.92	1.2	6
	1219	48	704	1554	1.07	1.4	7
Heavy Duty Rock	610	24	464	1025	0.34	0.45	3
	762	30	539	1190	0.47	0.62	4
	914	36	614	1355	0.61	0.8	5
	1067	42	668	1474	0.78	1.02	5
	1219	48	743	1640	0.88	1.15	6
	1295	51	708	1563	1.03	1.35	5
Ditch Cleaning	1524	60	572	1263	0.96	1.25	0
	1676	66	606	1338	1.06	1.38	0
	2007	79	424	935	0.54	0.7	0
Ditch Cleaning Tilt	1524	60	634	1400	0.67	0.87	0
	1803	71	362	800	0.48	0.63	0
	2007	79	392	866	0.54	0.7	0

- All bucket recommendations are subject to material density.
- All data is subject to change without notice.
- Contact your Caterpillar dealer for bucket availability and specifications.

# VA Boom – 2.1 m (6'11") stick

**Stick**  
2.1 m (6'11")

Stick 2.1 m (6'11")		Undercarriage configuration	3.0 m (10.0 ft)		4.5 m (15.0 ft)		6.0 m (20.0 ft)		7.5 m (25.0 ft)				m/ft	
														
 Load Point Height   Load Radius Over Front or Rear   Load Radius Over Side   Load at Maximum Reach	6.0 m (20.0 ft)	Rear dozer up (Load over front)	kg			*5500	4600	4600	2800					
		lb			*12,130	10,140	10,140	6,170						
		Rear dozer down (Load over rear)	kg			*5500	5200	*5100	3200					
		lb				*12,130	11,460	*11,240	7,060					
		Rear stab down (Load over rear)	kg			*5500	*5500	*5100	3900					
		lb				*12,130	*12,130	*11,240	8,600					
		2 sets stab down (Load over front)	kg			*5500	*5500	*5100	*5100					
		lb				*12,130	*12,130	*11,240	*11,240					
Dozer and stab down (Load over front)	kg			*5500	*5500	*5100	4700							
lb				*12,130	*12,130	*11,240	10,360							
4.5 m (15.0 ft)	Rear dozer up (Load over front)	kg	*6800	*6800	*6600	4500	4600	2900			*2600	1800	7.68 m (25'2")	
	lb	*14,990	*14,990	*14,550	9,920	10,140	6,390			*5,730	3,970			
	Rear dozer down (Load over rear)	kg	*6800	*6800	*6600	5100	*5400	3300			*2600	2100		
	lb	*14,990	*14,990	*14,550	11,240	*11,905	7,280				*5,730	4,630		
	Rear stab down (Load over rear)	kg	*6800	*6800	*6600	6100	*5400	4000			*2600	*2600		
	lb	*14,990	*14,990	*14,550	13,450	*11,905	8,820				*5,730	*5,730		
	2 sets stab down (Load over front)	kg	*6800	*6800	*6600	*6600	*5400	*5400			*2600	*2600		
	lb	*14,990	*14,990	*14,550	*14,550	*11,905	*11,905	*11,905			*5,730	*5,730		
Dozer and stab down (Load over front)	kg	*6800	*6800	*6600	*6600	*5400	4800			*2600	*2600			
lb	*14,990	*14,990	*14,550	*14,550	*11,905	10,580				*5,730	*5,730			
3.0 m (10.0 ft)	Rear dozer up (Load over front)	kg	*8700	8000	7000	4400	4600	2900	3100	1800	*2600	1600	8.11 m (26'7")	
	lb	*19,180	17,640	15,430	9,700	10,140	6,390	6,830	3,970	*5,730	3,530			
	Rear dozer down (Load over rear)	kg	*8700	*8700	*7800	5000	*5800	3300	*4500	2100	*2600	1900		
	lb	*19,180	*19,180	*17,800	11,020	*12,790	7,280	*9,920	4,630	*5,730	*4,190	4,190		
	Rear stab down (Load over rear)	kg	*8700	*8700	*7800	6000	*5800	3900	4200	2600	*2600	2300		
	lb	*19,180	*19,180	*17,800	13,230	*12,790	8,600	9,260	5,730	*5,730	*5,730	5,070		
	2 sets stab down (Load over front)	kg	*8700	*8700	*7800	*7800	*5800	*5400	*4500	3800	*2600	*2600		
	lb	*19,180	*19,180	*17,800	*17,800	*12,790	*11,910	*9,920	8,380	*5,730	*5,730	*5,730		
Dozer and stab down (Load over front)	kg	*8700	*8700	*7800	7200	*5800	4700	*4900	3200	*2600	*2600			
lb	*19,180	*19,180	*17,800	15,870	*12,790	10,360	*9,920	7,060	*5,730	*5,730	*5,730			
1.5 m (5.0 ft)	Rear dozer up (Load over front)	kg	*10 500	7700	6900	4300	4600	2800	3100	1800	*2700	1600	8.21 m (26'11")	
	lb	*23,149	16,980	15,210	9,480	10,140	6,170	6,830	3,970	*5,950	3,530			
	Rear dozer down (Load over rear)	kg	*10 500	9000	*8600	5000	*6200	3200	4800	2100	*2700	1800		
	lb	*23,149	19,840	*18,960	11,020	*13,670	7,060	10,580	4,630	*5,950	*3,970	3,970		
	Rear stab down (Load over rear)	kg	*10 500	*10 500	*8600	5900	*6000	3900	4200	2600	*2700	2200		
	lb	*23,149	*23,149	*18,960	13,010	*13,230	8,600	9,260	5,730	*5,950	*4,800	4,800		
	2 sets stab down (Load over front)	kg	*10 500	*10 500	*8600	8300	*6200	*5400	*4900	3700	*2700	*2700		
	lb	*23,149	*23,149	*18,960	18,300	*13,670	*11,910	*10,800	8,160	*5,950	*5,950	*5,950		
Dozer and stab down (Load over front)	kg	*10 500	*10 500	*8600	7100	*6200	4700	*4900	3200	*2700	*2700			
lb	*23,149	*23,149	*18,960	15,650	*13,670	10,360	*10,800	7,060	*5,950	*5,950	*5,950			
Ground	Rear dozer up (Load over front)	kg	*12 700	7300	7000	4200	4400	2700	3000	1700	2800	1600	7.99 m (26'2")	
	lb	*27,999	16,090	15,430	9,260	9,700	5,950	6,610	3,750	6,170	3,530			
	Rear dozer down (Load over rear)	kg	*12 700	8700	*8700	4800	*6300	3100	*4200	2000	*2900	1900		
	lb	*27,999	19,180	*19,180	10,580	*13,890	6,830	*9,260	4,410	*6,390	4,190	4,190		
	Rear stab down (Load over rear)	kg	*12 700	11 100	*8700	5900	*6100	3700	4100	2500	*2900	2300		
	lb	*27,999	24,471	*19,180	13,010	*13,450	8,160	9,040	5,510	*6,390	5,070	5,070		
	2 sets stab down (Load over front)	kg	*12 700	*12 700	*8700	8300	*6300	5400	*4200	3700	*2900	*2900		
	lb	*27,999	*27,999	*19,180	18,300	*13,890	11,910	*9,260	8,160	*6,390	*6,390	*6,390		
Dozer and stab down (Load over front)	kg	*12 700	*12 700	*8700	7200	*6300	4600	*4200	3100	*2900	*2900			
lb	*27,999	*27,999	*19,180	15,870	*13,890	10,140	*9,260	6,830	*6,390	*6,390	*6,390			
-1.5 m (-5.0 ft)	Rear dozer up (Load over front)	kg	13 800	7300	6900	4000	4300	2500			3100	1800	7.42 m (24'4")	
	lb	30,424	16,090	15,210	8,820	9,480	5,510			6,830	3,970			
	Rear dozer down (Load over rear)	kg	*14 100	8600	*8800	4700	*6300	2900			*3200	2100		
	lb	*31,085	18,960	*19,400	10,360	*13,890	6,390				*7,060	4,630		
	Rear stab down (Load over rear)	kg	*14 100	11 100	*8800	5700	*6000	3600			*3200	2600		
	lb	*31,085	24,471	*19,400	12,570	*13,230	7,490				*7,060	5,730		
	2 sets stab down (Load over front)	kg	*14 100	*14 100	*8800	8600	*6300	5200			*3200	*3200		
	lb	*31,085	*31,085	*19,400	18,960	*13,890	11,460				*7,060	*7,060		
Dozer and stab down (Load over front)	kg	*14 100	14 000	*8800	7100	*6300	4400			*3200	*3200			
lb	*31,085	30,865	*19,400	15,650	*13,890	9,700				*7,060	*7,060			
-3.0 m (-10.0 ft)	Rear dozer up (Load over front)	kg	14 000	7400	6700	3800								
	lb	30,865	16,314	14,770	8,380									
	Rear dozer down (Load over rear)	kg	*14 300	8700	8100	4500								
	lb	*31,526	19,180	17,860	9,920									
	Rear stab down (Load over rear)	kg	*14 300	11 200	*8100	5500								
	lb	*31,526	24,692	*17,860	12,125									
	2 sets stab down (Load over front)	kg	*14 300	*14 300	*8100	*8100								
	lb	*31,526	*31,526	*17,860	*17,860									
Dozer and stab down (Load over front)	kg	*14 300	*14 300	*8100	6900									
lb	*31,526	*31,526	*17,860	15,212										

- \* Indicates that the load is limited by hydraulic capacity rather than tipping capacity. Lift capacity ratings are based on SAE standard JISO 10567. Rated loads do not exceed 87% of hydraulic lifting capacity or 75% of tipping load.
- All lift capacities are calculated with Heavy Lift on.
  - Oscillating axle must be locked.
  - All values are calculated at the stick-nose.

# VA Boom – 2.4 m (7'10") stick

**Stick**  
2.4 m (7'10")



Load Point Height



Load Radius Over Front or Rear



Load Radius Over Side

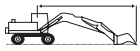











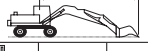



Load at Maximum Reach

Undercarriage configuration	3.0 m (10.0 ft)		4.5 m (15.0 ft)		6.0 m (20.0 ft)		7.5 m (25.0 ft)		m/ft			
6.0 m (20.0 ft)	Rear dozer up (Load over front)	kg			*4800	4600	4600	2900				
	Rear dozer up (Load over front)	lb			*10,580	10,140	10,140	6,390				
	Rear dozer down (Load over rear)	kg			*4800	*4800	*4700	3300				
	Rear dozer down (Load over rear)	lb			*10,580	*10,580	*10,360	7,280				
	Rear stab down (Load over rear)	kg			*4800	*4800	*4700	4000				
	Rear stab down (Load over rear)	lb			*10,580	*10,580	*10,360	8,820				
	2 sets stab down (Load over front)	kg			*4800	*4800	*4700	*4700				
	2 sets stab down (Load over front)	lb			*10,580	*10,580	*10,360	*10,360				
4.5 m (15.0 ft)	Dozer and stab down (Load over front)	kg			*4800	*4800	*4700	*4700				
	Dozer and stab down (Load over front)	lb			*10,580	*10,580	*10,360	*10,360				
	Rear dozer up (Load over front)	kg	*5100	*5100	*5600	4500	4600	2900	*3000	1900	*2300	1700
	Rear dozer up (Load over front)	lb	*11,240	*11,240	*12,350	9,920	10,140	6,390	*6,610	4,190	*5,070	3,750
	Rear dozer down (Load over rear)	kg	*5100	*5100	*5600	5100	*5300	3300	*3000	2100	*2300	2000
	Rear dozer down (Load over rear)	lb	*11,240	*11,240	*12,350	11,240	*11,690	7,280	*6,610	4,630	*5,070	4,410
	Rear stab down (Load over rear)	kg	*5100	*5100	*5600	*5600	*5300	4000	*3000	2600	*2300	*2300
	Rear stab down (Load over rear)	lb	*11,240	*11,240	*12,350	*12,350	*11,690	8,820	*6,610	5,730	*5,070	*5,070
3.0 m (10.0 ft)	2 sets stab down (Load over front)	kg	*5100	*5100	*5600	*5600	*5300	*5300	*3000	*3000	*2300	*2300
	2 sets stab down (Load over front)	lb	*11,240	*11,240	*12,350	*12,350	*11,690	*11,690	*6,610	*6,610	*5,070	*5,070
	Dozer and stab down (Load over front)	kg	*5100	*5100	*5600	*5600	*5300	4700	*3000	*3000	*2300	*2300
	Dozer and stab down (Load over front)	lb	*11,240	*11,240	*12,350	*12,350	*11,690	10,360	*6,610	*6,610	*5,070	*5,070
	Rear dozer up (Load over front)	kg	*9400	8000	7000	4400	4600	2900	3100	1900	*2300	1500
	Rear dozer up (Load over front)	lb	*20,720	17,640	15,430	9,700	10,140	6,390	6,830	4,190	*5,070	3,310
	Rear dozer down (Load over rear)	kg	*9400	9100	*7500	5000	*5600	3300	*4500	2100	*2300	1800
	Rear dozer down (Load over rear)	lb	*20,720	20,060	*16,540	11,020	*12,350	7,280	*9,920	4,630	*5,070	3,970
1.5 m (5.0 ft)	Rear stab down (Load over rear)	kg	*9400	*9400	*7500	6000	*5600	3900	4300	2600	*2300	2200
	Rear stab down (Load over rear)	lb	*20,720	*20,720	*16,540	13,230	*12,350	8,600	9,480	5,730	*5,070	4,850
	2 sets stab down (Load over front)	kg	*9400	*9400	*7500	*7500	*5600	*5400	*4500	3800	*2300	*2300
	2 sets stab down (Load over front)	lb	*20,720	*20,720	*16,540	*16,540	*12,350	*11,910	*9,920	8,380	*5,070	*5,070
	Dozer and stab down (Load over front)	kg	*9400	*9400	*7500	7100	*5600	4700	*4500	3200	*2300	*2300
	Dozer and stab down (Load over front)	lb	*20,720	*20,720	*16,540	15,650	*12,350	10,360	*9,920	7,060	*5,070	*5,070
	Rear dozer up (Load over front)	kg	*10,700	7800	6900	4300	4600	2900	3100	1800	*2400	1500
	Rear dozer up (Load over front)	lb	*23,590	17,800	15,210	9,480	10,140	6,390	6,830	3,970	*5,291	3,310
Ground	Rear dozer down (Load over rear)	kg	*10,700	8900	*8500	5000	*6200	3300	*4800	2100	*2400	1700
	Rear dozer down (Load over rear)	lb	*23,590	19,620	*18,740	11,020	*13,670	7,280	*10,580	4,630	*5,291	3,750
	Rear stab down (Load over rear)	kg	*10,700	*10,700	*8500	5900	6000	3900	4200	2600	*2400	2100
	Rear stab down (Load over rear)	lb	*23,590	*23,590	*18,740	13,010	13,230	8,600	9,260	5,732	*5,291	4,630
	2 sets stab down (Load over front)	kg	*10,700	*10,700	*8500	*8300	*6200	5400	*4800	3800	*2400	*2400
	2 sets stab down (Load over front)	lb	*23,590	*23,590	*18,740	*18,300	*13,670	11,910	*10,580	8,378	*5,291	*5,291
	Dozer and stab down (Load over front)	kg	*10,700	*10,700	*8500	7100	*6200	4700	*4800	3200	*2400	*2400
	Dozer and stab down (Load over front)	lb	*23,590	*23,590	*18,740	15,650	*13,670	*10,360	*10,580	7,055	*5,291	*5,291
-1.5 m (-5.0 ft)	Rear dozer up (Load over front)	kg	*12,500	7600	6900	4200	4400	2700	3000	1800	*2500	1500
	Rear dozer up (Load over front)	lb	*27,558	16,760	15,210	9,260	9,700	5,950	6,610	3,970	*5,510	3,310
	Rear dozer down (Load over rear)	kg	*12,500	8900	*8600	4800	*6200	3100	*4700	2000	*2500	1800
	Rear dozer down (Load over rear)	lb	*27,558	19,620	*18,960	10,580	*13,670	6,830	*10,360	4,410	*5,510	3,970
	Rear stab down (Load over rear)	kg	*12,500	11,200	*8600	5900	6000	3800	4100	2500	*2500	2200
	Rear stab down (Load over rear)	lb	*27,558	24,692	*18,960	13,010	13,230	8,380	9,040	5,510	*5,510	4,850
	2 sets stab down (Load over front)	kg	*12,500	*12,500	*8600	8300	*6200	5400	*4700	3700	*2500	*2500
	2 sets stab down (Load over front)	lb	*27,558	*27,558	*18,960	18,300	*13,670	11,910	*10,360	8,160	*5,510	*5,510
-3.0 m (-10.0 ft)	Dozer and stab down (Load over front)	kg	*12,500	*12,500	*8600	*7100	*6200	4600	*4700	3100	*2500	*2500
	Dozer and stab down (Load over front)	lb	*27,558	*27,558	*18,960	*15,650	*13,670	10,140	*10,360	6,830	*5,510	*5,510
	Rear dozer up (Load over front)	kg	13,900	7300	6700	3900	4200	2400			*2900	1700
	Rear dozer up (Load over front)	lb	30,644	16,090	14,770	8,600	9,260	5,290			*6,390	3,750
	Rear dozer down (Load over rear)	kg	*14,400	8600	8700	4500	*4600	2800			*2900	1900
	Rear dozer down (Load over rear)	lb	*31,747	18,960	19,180	9,920	*10,140	6,170			*6,390	4,190
	Rear stab down (Load over rear)	kg	*14,400	11,100	*8700	5500	*4600	3500			*2900	2400
	Rear stab down (Load over rear)	lb	*31,747	24,471	*19,180	12,130	*10,140	7,720			*6,390	5,290
Stick	2 sets stab down (Load over front)	kg	*14,400	*14,400	*8700	8400	*4600	*4600			*2900	*2900
	2 sets stab down (Load over front)	lb	*31,747	*31,747	*19,180	18,520	*13,890	11,690			*6,390	*6,390
	Dozer and stab down (Load over front)	kg	*14,400	14,300	*8700	6900	*4600	4400			*2900	*2900
	Dozer and stab down (Load over front)	lb	*31,747	31,526	*19,180	15,210	*13,890	9,700			*6,390	*6,390

\* Indicates that the load is limited by hydraulic capacity rather than tipping capacity. Lift capacity ratings are based on SAE standard JISO 10567. Rated loads do not exceed 87% of hydraulic lifting capacity or 75% of tipping load.

- All lift capacities are calculated with Heavy Lift on.
- Oscillating axle must be locked.
- All values are calculated at the stick-nose.

# VA Boom – 2.6 m (8'6") stick

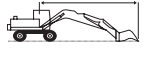
Stick 2.6 m (8'6")		Undercarriage configuration		3.0 m (10.0 ft)		4.5 m (15.0 ft)		6.0 m (20.0 ft)		7.5 m (25.0 ft)					
														m/ft	
				kg	lb	kg	lb	kg	lb	kg	lb	kg	lb		
	6.0 m (20.0 ft)	Rear dozer up (Load over front)	kg		*4300	*4300	*4400	2900							
			lb		*9,480	*9,480	*9,700	6,390							
			Rear dozer down (Load over rear)	kg		*4300	*4300	*4400	3300						
			lb		*9,480	*9,480	*9,700	7,280							
			Rear stab down (Load over rear)	kg		*4300	*4300	*4400	4000						
			lb		*9,480	*9,480	*9,700	8,820							
			2 sets stab down (Load over front)	kg		*4300	*4300	*4400	*4400						
lb		*9,480	*9,480	*9,700	*9,700										
	4.5 m (15.0 ft)	Rear dozer up (Load over front)	kg		*5000	4500	4600	2900	3200	1900	*2100	1700	8.18 m (28'10")		
			lb		*11,020	9,920	10,140	6,390	7,060	4,190	*4,630	3,750			
			Rear dozer down (Load over rear)	kg		*5000	*5000	5000	3300	*3600	2200	*2100		1900	
			lb		*11,020	*11,020	*11,020	7,280	*7,940	4,850	*4,630	4,190		*4,630	
			Rear stab down (Load over rear)	kg		*5000	*5000	5000	4000	*3600	2700	*2100		*2100	
			lb		*11,020	*11,020	*11,020	8,820	*7,940	5,950	*4,630	*4,630		*4,630	
			2 sets stab down (Load over front)	kg		*5000	*5000	*5000	*3600	*3600	*2100	*2100		*2100	
lb		*11,020	*11,020	*11,020	*11,020	*7,940	*7,940	*4,630	*4,630	*4,630					
	3.0 m (10.0 ft)	Rear dozer up (Load over front)	kg	*9300	8000	4400	4600	2900	3200	1900	*2100	1500	8.58 m (28'1")		
			lb	*20,500	17,640	9,700	10,140	6,390	7,060	4,190	*4,630	3,310			
			Rear dozer down (Load over rear)	kg	*9300	9200	*7400	5000	*5600	3300	*4600	2200		*2100	
			lb	*20,500	20,280	*16,310	11,020	*12,350	7,280	*10,140	4,850	*4,630		3,750	
			Rear stab down (Load over rear)	kg	*9300	*9300	*7400	6000	*5600	3900	4300	2700		*2100	
			lb	*20,500	*20,500	*16,310	13,230	*12,350	8,600	9,480	5,950	*4,630		*4,630	
			2 sets stab down (Load over front)	kg	*9300	*9300	*7400	*7400	*5600	*5400	*4600	3800		*2100	*2100
lb	*20,500	*20,500	*16,310	*16,310	*12,350	*11,910	*10,140	8,380	*4,630	*4,630					
	1.5 m (5.0 ft)	Rear dozer up (Load over front)	kg	*10,600	7800	6900	4300	2900	3100	1800	*2100	1400	8.67 m (28'8")		
			lb	*23,369	17,800	15,210	9,480	10,140	6,390	6,830	3,970	*4,850		3,090	
			Rear dozer down (Load over rear)	kg	*10,600	8900	*8400	4900	*6100	3300	*4800	2100		*2200	
			lb	*23,369	19,620	*18,520	10,800	*13,450	7,280	*10,580	4,630	*4,850		3,750	
			Rear stab down (Load over rear)	kg	*10,600	*10,600	*8400	*5900	6000	3900	4200	2600		*2200	2000
			lb	*23,369	*23,369	*18,520	*13,010	13,230	8,600	9,260	5,730	*4,850		4,410	
			2 sets stab down (Load over front)	kg	*10,600	*10,600	*8400	8300	*6100	5400	*4800	3800		*2200	*2200
lb	*23,369	*23,369	*18,520	18,300	*13,450	11,910	*10,580	8,380	*4,850	*4,850					
Ground	-1.5 m (-5.0 ft)	Rear dozer up (Load over front)	kg	*12,200	7600	6900	4200	2700	3000	1800	*2300	1400	8.46 m (27'9")		
			lb	*26,896	16,760	15,210	9,260	9,920	5,950	6,610	3,970	*5,070		3,090	
			Rear dozer down (Load over rear)	kg	*12,200	9000	*8600	4800	*6200	3100	4800	2100		*2300	
			lb	*26,896	19,840	*18,960	10,580	*13,670	6,830	10,580	4,630	*5,070		3,750	
			Rear stab down (Load over rear)	kg	*12,200	11,100	*8600	5900	6000	3800	4200	2500		*2300	2100
			lb	*26,896	24,471	*18,960	13,010	13,230	8,380	9,260	5,510	*5,070		4,630	
			2 sets stab down (Load over front)	kg	*12,200	*12,200	*8600	*8200	*6200	5500	*4800	3700		*2300	*2300
lb	*26,896	*26,896	*18,960	*18,080	*13,670	12,130	*10,580	8,160	*5,070	*5,070					
-3.0 m (-10.0 ft)	-3.0 m (-10.0 ft)	Rear dozer up (Load over front)	kg	13,500	7300	6900	4000	4300	2500	3000	1700	*2600	1600	7.94 m (26'0")	
			lb	29,762	16,090	15,210	8,820	9,480	5,510	6,610	3,750	*5,730	3,530		
			Rear dozer down (Load over rear)	kg	*14,000	8600	*8700	4700	*6300	2900	*3300	2000	*2600		1900
			lb	*30,865	18,960	*19,180	10,360	*13,890	6,390	*7,280	4,410	*5,730	4,190		
			Rear stab down (Load over rear)	kg	*14,000	11,100	*8700	5700	6000	3600	*3300	2500	*2600		2300
			lb	*30,865	24,471	*19,180	12,570	13,230	7,940	*7,280	5,510	*5,730	5,070		
			2 sets stab down (Load over front)	kg	*14,000	*14,000	*8700	*8400	*6300	5300	*3300	*3300	*2600		*2600
lb	*30,865	*30,865	*19,180	*8,520	*13,890	11,690	*7,280	*7,280	*5,730	*5,730					
-4.5 m (-15.0 ft)	-4.5 m (-15.0 ft)	Rear dozer up (Load over front)	kg	10,100	7200	6700	3900	4200	2400						
			lb	22,267	15,870	14,770	8,600	9,260	5,290						
			Rear dozer down (Load over rear)	kg	*14,400	8600	*8900	4500	*5200	2800					
			lb	*31,747	18,960	*19,620	9,920	*11,460	6,170						
			Rear stab down (Load over rear)	kg	*14,400	11,000	*8900	5600	*5200	3500					
			lb	*31,747	24,251	*19,620	12,350	*11,460	7,720						
			2 sets stab down (Load over front)	kg	*14,400	*14,400	*8900	8400	*5200	5200					
lb	*31,747	*31,747	*19,620	18,520	*11,460	11,460									
* Indicates that the load is limited by hydraulic capacity rather than tipping capacity. Lift capacity ratings are based on SAE standard JISO 10567. Rated loads do not exceed 87% of hydraulic lifting capacity or 75% of tipping load.	Dozer and stab down (Load over front)	kg	*14,400	14,200	*8900	6900	*5200	4300							
		lb	*31,747	31,306	*19,620	15,210	*11,460	9,480							
		Rear dozer up (Load over front)	kg	10,100	7200	6700	3900	4200	2400						
		lb	22,267	15,870	14,770	8,600	9,260	5,290							
		Rear dozer down (Load over rear)	kg	*10,100	8500										
		lb	*22,267	18,740											
		Rear stab down (Load over rear)	kg	*10,100	*10,100										
lb	*22,267	*22,267													
2 sets stab down (Load over front)	kg	*10,100	*10,100												
lb	*22,267	*22,267													
Dozer and stab down (Load over front)	kg	*10,100	*10,100												
lb	*22,267	*22,267													

\* Indicates that the load is limited by hydraulic capacity rather than tipping capacity. Lift capacity ratings are based on SAE standard JISO 10567. Rated loads do not exceed 87% of hydraulic lifting capacity or 75% of tipping load.

- All lift capacities are calculated with Heavy Lift on.
- Oscillating axle must be locked.
- All values are calculated at the stick-nose.



# One-piece Boom – 2.1 m (6'11") stick

Stick  
2.1 m (6'11")



Load Point  
Height



Load Radius  
Over Front  
or Rear



Load Radius  
Over Side

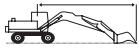











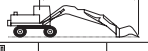



Load at  
Maximum Reach

Undercarriage configuration	3.0 m (10.0 ft)		4.5 m (15.0 ft)		6.0 m (20.0 ft)		7.5 m (25.0 ft)		m/ft		
	kg	lb	kg	lb	kg	lb	kg	lb	kg	lb	
6.0 m (20.0 ft)	Rear dozer up (Load over front)	kg				*4400	2800				
	Rear dozer down (Load over front)	lb				*9,700	6,170				
	Rear dozer up (Load over rear)	kg				*4400	3200				
	Rear dozer down (Load over rear)	lb				*9,700	7,060				
	Rear stab down (Load over rear)	kg				*4400	3900				
	Rear stab down (Load over front)	lb				*9,700	8,600				
	2 sets stab down (Load over front)	kg				*4400	*4400				
	Dozer and stab down (Load over front)	lb				*9,700	*9,700				
4.5 m (15.0 ft)	Rear dozer up (Load over front)	kg			*6300	4400	4500	2800		*2600	2000
	Rear dozer down (Load over front)	lb			*13,890	9,700	9,920	6,170		*5,730	4,410
	Rear dozer up (Load over rear)	kg			*6300	5000	*5400	3200		*2600	2300
	Rear dozer down (Load over rear)	lb			*13,890	11,020	*11,910	7,060		*5,730	5,070
	Rear stab down (Load over rear)	kg			*6300	6100	*5400	3800		*2600	*2600
	Rear stab down (Load over front)	lb			*13,890	13,450	*11,910	8,380		*5,730	*5,730
	2 sets stab down (Load over front)	kg			*6300	*6300	*5400	*5400		*2600	*2600
	Dozer and stab down (Load over front)	lb			*13,890	*13,890	*11,910	*11,910		*5,730	*5,730
3.0 m (10.0 ft)	Rear dozer up (Load over front)	kg			6900	4100	4400	2700		*2600	1800
	Rear dozer down (Load over front)	lb			15,210	9,040	9,700	5,950		*5,730	3,970
	Rear dozer up (Load over rear)	kg			*7600	4700	*5800	3100		*2600	2000
	Rear dozer down (Load over rear)	lb			*16,760	10,360	*12,790	6,830		*5,730	4,410
	Rear stab down (Load over rear)	kg			*7600	5700	*5800	3700		*2600	2400
	Rear stab down (Load over front)	lb			*16,760	12,570	*12,790	8,160		*5,730	5,290
	2 sets stab down (Load over front)	kg			*7600	*7600	*5800	5400		*2600	*2600
	Dozer and stab down (Load over front)	lb			*16,760	*16,760	*12,790	11,910		*5,730	*5,730
1.5 m (5.0 ft)	Rear dozer up (Load over front)	kg			3800	3800	4300	2500	3100	1800	2700
	Rear dozer down (Load over front)	lb			14,550	8,380	9,480	5,510	6,830	3,970	5,950
	Rear dozer up (Load over rear)	kg			*8600	4400	*6300	2900	*3900	2100	2700
	Rear dozer down (Load over rear)	lb			*18,960	9,700	*13,890	6,390	*8,600	4,630	5,950
	Rear stab down (Load over rear)	kg			*8600	5400	6000	3600	*3900	2600	*2700
	Rear stab down (Load over front)	lb			*18,960	11,910	13,230	7,940	*8,600	5,730	*5,950
	2 sets stab down (Load over front)	kg			*8600	8200	*6300	5200	*3900	3700	*2700
	Dozer and stab down (Load over front)	lb			*18,960	18,080	*13,890	11,460	*8,600	8,160	*5,950
Ground	Rear dozer up (Load over front)	kg			3700	4200	2500				*2900
	Rear dozer down (Load over front)	lb			14,110	8,160	9,260	5,510			*6,390
	Rear dozer up (Load over rear)	kg			*8800	4200	*6400	2800			*2900
	Rear dozer down (Load over rear)	lb			*19,401	9,260	*14,110	6,170			*6,390
	Rear stab down (Load over rear)	kg			*8800	5300	5800	3500			*2900
	Rear stab down (Load over front)	lb			*19,401	11,690	12,790	7,720			*6,390
	2 sets stab down (Load over front)	kg			*8800	8000	*6400	5100			*2900
	Dozer and stab down (Load over front)	lb			*19,401	17,640	*14,110	11,240			*6,390
-1.5 m (-5.0 ft)	Rear dozer up (Load over front)	kg			*8000	6600	6300	4100	2400		3200
	Rear dozer down (Load over front)	lb			*17,640	14,550	13,890	7,940	9,040	5,290	7,060
	Rear dozer up (Load over rear)	kg			*8000	7900	*8000	4200	*5800	2800	*3400
	Rear dozer down (Load over rear)	lb			*17,640	17,420	*17,640	9,260	*12,790	6,170	*7,500
	Rear stab down (Load over rear)	kg			*8000	*8000	*8000	5200	*5800	3500	*3400
	Rear stab down (Load over front)	lb			*17,640	*17,640	*17,640	11,460	*12,790	7,720	*7,500
	2 sets stab down (Load over front)	kg			*8000	*8000	*8000	8000	*5800	5100	*3400
	Dozer and stab down (Load over front)	lb			*17,640	*17,640	*17,640	17,640	*12,790	11,240	*7,500
-3.0 m (-10.0 ft)	Rear dozer up (Load over front)	kg			*8300	6800	*6200	3700			
	Rear dozer down (Load over front)	lb			*18,300	14,990	*13,670	8,160			
	Rear dozer up (Load over rear)	kg			*8300	8100	*6200	4300			
	Rear dozer down (Load over rear)	lb			*18,300	17,860	*13,670	9,480			
	Rear stab down (Load over rear)	kg			*8300	*8300	*6200	5300			
	Rear stab down (Load over front)	lb			*18,300	*18,300	*13,670	11,690			
	2 sets stab down (Load over front)	kg			*8300	*8300	*6200	*6200			
	Dozer and stab down (Load over front)	lb			*18,300	*18,300	*13,670	*13,670			

\* Indicates that the load is limited by hydraulic capacity rather than tipping capacity. Lift capacity ratings are based on SAE standard JISO 10567. Rated loads do not exceed 87% of hydraulic lifting capacity or 75% of tipping load.

- All lift capacities are calculated with Heavy Lift on.
- Oscillating axle must be locked.
- All values are calculated at the stick-nose.

# One-piece Boom – 2.4 m (7'10") stick

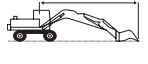
Stick 2.4 m (7'10")		Undercarriage configuration	3.0 m (10.0 ft)		4.5 m (15.0 ft)		6.0 m (20.0 ft)		7.5 m (25.0 ft)				
													m/ft
	6.0 m (20.0 ft)	Rear dozer up (Load over front)	kg					*4400	2800				
		lb						*9,700	6,170				
	6.0 m (20.0 ft)	Rear dozer down (Load over rear)	kg					*4400	3200				
		lb						*9,700	7,060				
	6.0 m (20.0 ft)	Rear stab down (Load over rear)	kg					*4400	3900				
		lb						*9,700	8,600				
	6.0 m (20.0 ft)	2 sets stab down (Load over front)	kg					*4400	*4400				
		lb						*9,700	*9,700				
	6.0 m (20.0 ft)	Dozer and stab down (Load over front)	kg					*4400	*4400				
		lb						*9,700	*9,700				
	4.5 m (15.0 ft)	Rear dozer up (Load over front)	kg					4500	2800			*2300	1900
		lb						9,920	6,170			*5,070	4,190
	4.5 m (15.0 ft)	Rear dozer down (Load over rear)	kg					*5100	3200			*2300	2100
		lb						*11,240	7,060			*5,070	4,630
	4.5 m (15.0 ft)	Rear stab down (Load over rear)	kg					*5100	3900			*2300	*2300
		lb						*11,240	8,600			*5,070	*5,070
	4.5 m (15.0 ft)	2 sets stab down (Load over front)	kg					*5100	*5100			*2300	*2300
		lb						*11,240	*11,240			*5,070	*5,070
	4.5 m (15.0 ft)	Dozer and stab down (Load over front)	kg					*5100	4700			*2300	*2300
		lb						*11,240	10,360			*5,070	*5,070
	3.0 m (10.0 ft)	Rear dozer up (Load over front)	kg			6900	4100	4400	2700	3100	1900	*2300	1700
		lb			15,210	9,040	9,700	5,950	6,830	4,190	*5,070	3,750	
	3.0 m (10.0 ft)	Rear dozer down (Load over rear)	kg			*7300	4700	*5700	3100	*4000	2100	*2300	1900
		lb			*16,090	10,360	*12,570	6,830	*8,820	4,630	*5,070	4,190	
	3.0 m (10.0 ft)	Rear stab down (Load over rear)	kg			*7300	5800	*5700	3700	*4000	2600	*2300	*2300
		lb			*16,090	12,790	*12,570	8,160	*8,820	5,730	*5,070	*5,070	
	3.0 m (10.0 ft)	2 sets stab down (Load over front)	kg			*7300	*7300	*5700	5400	*4000	3800	*2300	*2300
		lb			*16,090	*16,090	*12,570	11,910	*8,820	8,380	*5,070	*5,070	
	3.0 m (10.0 ft)	Dozer and stab down (Load over front)	kg			*7300	7100	*5700	4600	*4000	3200	*2300	*2300
		lb			*16,090	15,650	*12,570	10,140	*8,820	7,060	*5,070	*5,070	
	1.5 m (5.0 ft)	Rear dozer up (Load over front)	kg			6600	3800	4300	2500	3000	1800	*2600	1600
		lb			14,550	8,380	9,480	5,510	6,610	3,970	*5,290	3,530	
	1.5 m (5.0 ft)	Rear dozer down (Load over rear)	kg			*8400	4400	*6200	2900	4800	2100	*2400	1800
		lb			*18,520	9,700	*13,670	6,390	10,580	4,630	*5,290	3,970	
	1.5 m (5.0 ft)	Rear stab down (Load over rear)	kg			*8400	5500	6000	3600	4200	2600	*2400	2200
		lb			*18,520	12,130	13,230	7,940	9,260	5,730	*5,290	4,850	
	1.5 m (5.0 ft)	2 sets stab down (Load over front)	kg			*8400	8200	*6200	5200	*4800	3700	*2400	*2400
		lb			*18,520	18,080	*13,670	11,460	*10,580	8,160	*5,291	*5,291	
	1.5 m (5.0 ft)	Dozer and stab down (Load over front)	kg			*8400	6800	*6200	4400	*4800	3200	*2400	*2400
		lb			*18,520	14,990	*13,670	9,700	*10,580	7,060	*5,291	*5,291	
	Ground	Rear dozer up (Load over front)	kg	*4000	*4000	6400	3600	4100	2400	3000	1800	*2600	1600
		lb	*8,820	*8,820	14,110	7,940	9,040	5,290	6,610	3,970	*5,730	3,530	
	Ground	Rear dozer down (Load over rear)	kg	*4000	*4000	*8800	4200	*6300	2800	*4100	2100	*2600	1900
		lb	*8,820	*8,820	*19,400	9,260	*13,890	6,170	*9,040	4,630	*5,730	4,190	
	Ground	Rear stab down (Load over rear)	kg	*4000	*4000	*8800	5300	5800	3500	*4100	2500	*2600	2300
		lb	*8,820	*8,820	*19,400	11,690	12,790	7,720	*9,040	5,510	*5,730	5,070	
	Ground	2 sets stab down (Load over front)	kg	*4000	*4000	*8800	8000	*6300	5100	*4100	3700	*2600	*2600
		lb	*8,820	*8,820	*19,400	17,640	*13,890	11,240	*9,040	8,160	*5,730	*5,730	
	Ground	Dozer and stab down (Load over front)	kg	*4000	*4000	*8800	6600	*6300	4300	*4100	3100	*2600	*2600
		lb	*8,820	*8,820	*19,400	14,550	*13,890	9,480	*9,040	6,830	*5,730	*5,730	
	-1.5 m (-5.0 ft)	Rear dozer up (Load over front)	kg	*7800	6600	6300	3600	4100	2400			*3000	1800
		lb	*17,800	14,550	13,890	7,940	9,040	5,290				*6,610	3,970
	-1.5 m (-5.0 ft)	Rear dozer down (Load over rear)	kg	*7800	*7800	*8200	4200	*6000	2800			*3000	2100
		lb	*17,800	*17,800	*18,080	9,260	*13,230	6,170				*6,610	4,630
	-1.5 m (-5.0 ft)	Rear stab down (Load over rear)	kg	*7800	*7800	*8200	5200	5800	3400			*3000	2500
		lb	*17,800	*17,800	*18,080	11,460	12,790	7,500				*6,610	5,510
	-1.5 m (-5.0 ft)	2 sets stab down (Load over front)	kg	*7800	*7800	*8200	7900	*6000	5100			*3000	*3000
		lb	*17,800	*17,800	*18,080	17,420	*13,230	11,240				*6,610	*6,610
	-1.5 m (-5.0 ft)	Dozer and stab down (Load over front)	kg	*7800	*7800	*8200	6500	*6000	4300			*3000	*3000
		lb	*17,800	*17,800	*18,080	14,330	*13,230	9,480				*6,610	*6,610
	-3.0 m (-10.0 ft)	Rear dozer up (Load over front)	kg	*9200	6700	6400	3600	4200	2500				
		lb	*20,280	14,770	14,110	7,940	9,260	5,510					
	-3.0 m (-10.0 ft)	Rear dozer down (Load over rear)	kg	*9200	8000	*6700	4200	*4400	2800				
		lb	*20,280	17,640	*14,770	9,260	*9,700	6,170					
	-3.0 m (-10.0 ft)	Rear stab down (Load over rear)	kg	*9200	*9200	*6700	5300	*4400	3500				
		lb	*20,280	*20,280	*14,770	11,690	*9,700	7,720					
	-3.0 m (-10.0 ft)	2 sets stab down (Load over front)	kg	*9200	*9200	*6700	*6700	*4400	*4400				
		lb	*20,280	*20,280	*14,770	*14,770	*9,700	*9,700					
	-3.0 m (-10.0 ft)	Dozer and stab down (Load over front)	kg	*9200	*9200	*6700	6600	*4400	4300				
		lb	*20,280	*20,280	*14,770	14,550	*9,700	9,480					

\* Indicates that the load is limited by hydraulic capacity rather than tipping capacity. Lift capacity ratings are based on SAE standard JISO 10567. Rated loads do not exceed 87% of hydraulic lifting capacity or 75% of tipping load.

- All lift capacities are calculated with Heavy Lift on.
- Oscillating axle must be locked.
- All values are calculated at the stick-nose.

# One-piece Boom – 2.6 m (8'6") stick

Stick  
2.6 m (8'6")



Load Point  
Height



Load Radius  
Over Front  
or Rear



Load Radius  
Over Side

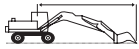

Load at  
Maximum Reach











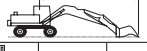



Stick 2.6 m (8'6")	Undercarriage configuration		3.0 m (10.0 ft)		4.5 m (15.0 ft)		6.0 m (20.0 ft)		7.5 m (25.0 ft)		m/ft		
			Front	Rear	Front	Rear	Front	Rear	Front	Rear	Front	Rear	
6.0 m (20.0 ft)	Rear dozer up (Load over front) Rear dozer down (Load over rear) Rear stab down (Load over rear) 2 sets stab down (Load over front) Dozer and stab down (Load over front)	kg					*4200	2900					
		lb					*9,260	6,390					
		kg					*4200	3300					
		lb					*9,260	7,280					
		kg					*4200	3900					
		lb					*9,260	8,600					
		kg					*4200	*4200					
4.5 m (15.0 ft)	Rear dozer up (Load over front) Rear dozer down (Load over rear) Rear stab down (Load over rear) 2 sets stab down (Load over front) Dozer and stab down (Load over front)	kg					4600	2800	*2500	1900	*2100	1800	
		lb					10,140	6,170	*5,510	4,190	*4,630	3,970	
		kg					*5000	3200	*2500	*2500	*2100	2000	
		lb					*11,020	7,060	*5,510	*5,510	*4,630	4,410	
		kg					*5000	3900	*2500	*2500	*2100	*2100	
		lb					*11,020	8,600	*5,510	*5,510	*4,630	*4,630	
		kg					*5000	*5000	*2500	*2500	*2100	*2100	
3.0 m (10.0 ft)	Rear dozer up (Load over front) Rear dozer down (Load over rear) Rear stab down (Load over rear) 2 sets stab down (Load over front) Dozer and stab down (Load over front)	kg				7000	4200	4400	2700	3100	1900	*2100	
		lb				15,430	9,260	9,700	5,950	6,830	4,190	*4,630	3,530
		kg				*7100	4800	*5500	3100	*4200	2200	*2100	1800
		lb				*15,650	10,580	*12,130	6,830	*9,260	4,850	*4,630	3,970
		kg				*7100	5800	*5500	3700	*4200	2600	*2100	*2100
		lb				*15,650	12,790	*12,130	8,160	*9,260	5,730	*4,630	*4,630
		kg				*7100	*7100	*5500	5400	*4200	3800	*2100	*2100
1.5 m (5.0 ft)	Rear dozer up (Load over front) Rear dozer down (Load over rear) Rear stab down (Load over rear) 2 sets stab down (Load over front) Dozer and stab down (Load over front)	kg				6600	3800	4300	2600	3100	1800	*2200	
		lb				14,550	8,380	9,480	5,730	6,830	3,970	*4,850	3,310
		kg				*8300	4400	*6100	2900	4800	2100	*2200	1800
		lb				*18,300	9,700	*13,450	6,390	10,580	4,630	*4,850	3,970
		kg				*8300	5500	6000	3600	4200	2600	*2200	*2200
		lb				*18,300	12,130	13,230	7,940	9,260	5,730	*4,850	*4,850
		kg				*8300	*8300	*6100	5200	*4900	3700	*2200	*2200
Ground	Rear dozer up (Load over front) Rear dozer down (Load over rear) Rear stab down (Load over rear) 2 sets stab down (Load over front) Dozer and stab down (Load over front)	kg	*4200	*4200	6400	3700	4200	2400	3000	1800	*2400	1600	
		lb	*9,260	*9,260	14,110	8,160	9,260	5,290	6,610	3,970	*5,290	3,530	
		kg	*4200	*4200	*8800	4200	*6300	2800	4700	2000	*2400	1800	
		lb	*9,260	*9,260	*19,400	9,260	*13,890	6,170	10,360	4,410	*5,290	3,970	
		kg	*4200	*4200	*8800	5300	5800	3500	4100	2500	*2400	2200	
		lb	*9,260	*9,260	*19,400	11,690	12,790	7,720	9,040	5,510	*5,290	4,850	
		kg	*4200	*4200	*8800	8000	*6300	5100	*4800	3700	*2400	*2400	
-1.5 m (-5.0 ft)	Rear dozer up (Load over front) Rear dozer down (Load over rear) Rear stab down (Load over rear) 2 sets stab down (Load over front) Dozer and stab down (Load over front)	kg	*7500	6500	6300	3600	4100	2400			*2800	1700	
		lb	*16,540	14,330	13,890	7,940	9,040	5,290			*6,170	3,750	
		kg	*7500	*7500	*8400	4200	*6000	2800			*2800	2000	
		lb	*16,540	*16,540	*18,520	9,260	*13,230	6,170			*6,170	4,410	
		kg	*7500	*7500	*8400	5200	5800	3400			*2800	2400	
		lb	*16,540	*16,540	*18,520	11,460	12,790	7,500			*6,170	5,290	
		kg	*7500	*7500	*8400	7900	*6000	5100			*2800	*2800	
-3.0 m (-10.0 ft)	Rear dozer up (Load over front) Rear dozer down (Load over rear) Rear stab down (Load over rear) 2 sets stab down (Load over front) Dozer and stab down (Load over front)	kg	*9700	6700	6400	3600	4100	2400					
		lb	*21,390	14,770	14,110	7,940	9,040	5,290					
		kg	*9700	7900	*6900	4200	*4800	2800					
		lb	*21,390	17,420	*15,210	9,260	*10,580	6,170					
		kg	*9700	*9700	*6900	5200	*4800	3500					
		lb	*21,390	*21,390	*15,210	11,460	*10,580	7,720					
		kg	*9700	*9700	*6900	*6900	*4800	*4800					
-3.0 m (-10.0 ft)	Rear dozer up (Load over front) Rear dozer down (Load over rear) Rear stab down (Load over rear) 2 sets stab down (Load over front) Dozer and stab down (Load over front)	kg	*21,390	14,770	14,110	7,940	9,040	5,290					
		lb	*47,500	32,600	31,100	17,420	19,700	11,690					
		kg	*9700	7900	*6900	4200	*4800	2800					
		lb	*21,390	17,420	*15,210	9,260	*10,580	6,170					
		kg	*9700	*9700	*6900	5200	*4800	3500					
		lb	*21,390	*21,390	*15,210	11,460	*10,580	7,720					
		kg	*9700	*9700	*6900	*6900	*4800	*4800					

\* Indicates that the load is limited by hydraulic capacity rather than tipping capacity. Lift capacity ratings are based on SAE standard JISO 10567. Rated loads do not exceed 87% of hydraulic lifting capacity or 75% of tipping load.

- All lift capacities are calculated with Heavy Lift on.
- Oscillating axle must be locked.
- All values are calculated at the stick-nose.

# Offset Boom – 2.1 m (6'11") stick

**Stick**  
2.1 m (6'11")

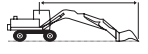
Stick 2.1 m (6'11")		Undercarriage configuration	3.0 m (10.0 ft)		4.5 m (15.0 ft)		6.0 m (20.0 ft)		7.5 m (25.0 ft)				
													m/ft
 Load Point Height   Load Radius Over Front or Rear   Load Radius Over Side   Load at Maximum Reach	6.0 m (20.0 ft)	Rear dozer up (Load over front)	kg			*5500	4600	4500	2700				
		lb			*12,130	10,140	9,920	5,950					
		Rear dozer down (Load over rear)	kg			*5500	5200	*5100	3100				
		lb				*12,130	11,460	*11,240	6,830				
		Rear stab down (Load over rear)	kg			*5500	*5500	*5100	3800				
		lb				*12,130	*12,130	*11,240	8,380				
		2 sets stab down (Load over front)	kg			*5500	*5500	*5100	*5100				
		lb				*12,130	*12,130	*11,240	*11,240				
Dozer and stab down (Load over front)	kg			*5500	*5500	*5100	4700						
lb				*12,130	*12,130	*11,240	10,360						
4.5 m (15.0 ft)	Rear dozer up (Load over front)	kg	*6900	*6900	4500	2800	4600	2800			*2300	1700	
	lb	*15,210	*15,210	*14,330	9,920	10,140	6,170			*5,070	3,750		
	Rear dozer down (Load over rear)	kg	*6900	*6900	*6500	5100	*5300	3200			*2300	2000	
	lb	*15,210	*15,210	*14,330	11,240	*11,680	7,060			*5,070	4,410		
	Rear stab down (Load over rear)	kg	*6900	*6900	*6500	6100	*5300	3900			*2300	*2300	
	lb	*15,210	*15,210	*14,330	13,450	*11,680	8,600			*5,070	*5,070		
	2 sets stab down (Load over front)	kg	*6900	*6900	*6500	*6500	*5300	*5300			*2300	*2300	
	lb	*15,210	*15,210	*14,330	*14,330	*11,680	*11,680	*11,680			*5,070	*5,070	
Dozer and stab down (Load over front)	kg	*6900	*6900	*6500	*6500	*5300	4700			*2300	*2300		
lb	*15,210	*15,210	*14,330	*14,330	*11,680	10,360			*5,070	*5,070			
3.0 m (10.0 ft)	Rear dozer up (Load over front)	kg	*7900	*7900	6900	4300	4500	2800	3000	1700	*2300	1500	
	lb	*17,420	*17,420	15,210	9,480	9,920	6,170	6,610	3,750	*5,070	3,310		
	Rear dozer down (Load over rear)	kg	*7900	*7900	*7600	5000	*5700	3200	*4400	2000	*2300	1800	
	lb	*17,420	*17,420	*16,760	11,020	*12,570	7,060	*9,700	4,410	*5,070	3,970		
	Rear stab down (Load over rear)	kg	*7900	*7900	*7600	5900	*5700	3900	4200	2500	*2300	2200	
	lb	*17,420	*17,420	*16,760	13,010	*12,570	8,600	9,260	5,510	*5,070	4,850		
	2 sets stab down (Load over front)	kg	*7900	*7900	*7600	*7600	*5700	*5300	*4400	3700	*2300	*2300	
	lb	*17,420	*17,420	*16,760	*16,760	*12,570	*11,680	*9,700	8,160	*5,070	*5,070		
Dozer and stab down (Load over front)	kg	*7900	*7900	*7600	7000	*5700	4600	*4400	3100	*2300	*2300		
lb	*17,420	*17,420	*16,760	15,430	*12,570	10,140	*9,700	6,830	*5,070	*5,070			
1.5 m (5.0 ft)	Rear dozer up (Load over front)	kg	*10 300	7600	6800	4300	4500	2700	2900	1700	*2300	1400	
	lb	*22,710	16,760	14,990	9,480	9,920	5,950	6,390	3,750	*5,070	3,090		
	Rear dozer down (Load over rear)	kg	*10 300	8900	*8300	4900	*6000	3100	*4700	1900	*2300	1700	
	lb	*22,710	19,620	*18,300	10,800	*13,230	6,830	*10,360	4,190	*5,070	3,750		
	Rear stab down (Load over rear)	kg	*10 300	*10 300	*8300	5800	5900	3800	4100	2400	*2300	2100	
	lb	*22,710	*22,710	*18,300	12,790	13,010	8,380	9,040	5,290	*5,070	4,630		
	2 sets stab down (Load over front)	kg	*10 300	*10 300	*8300	*8100	*6000	*5300	*4700	3600	*2300	*2300	
	lb	*22,710	*22,710	*18,300	*17,860	*13,230	*11,680	*10,360	7,940	*5,070	*5,070		
Dozer and stab down (Load over front)	kg	*10 300	*10 300	*8300	7000	*6000	4600	*4700	3000	*2300	*2300		
lb	*22,710	*22,710	*18,300	15,430	*13,230	10,140	*10,360	6,610	*5,070	*5,070			
Ground	Rear dozer up (Load over front)	kg	*12 600	7100	6900	4100	4300	2500	2900	1600	*2500	1500	
	lb	*27,780	15,650	15,210	9,040	9,480	5,510	6,390	3,530	*5,510	3,310		
	Rear dozer down (Load over rear)	kg	*12 600	8400	*8400	4700	*6100	2900	*4000	1900	*2500	1700	
	lb	*27,780	18,520	*18,520	10,360	*13,450	6,390	*8,820	4,190	*5,510	3,750		
	Rear stab down (Load over rear)	kg	*12 600	10 900	*8400	5800	6000	3600	*4000	2400	*2500	2200	
	lb	*27,780	24,030	*18,520	12,790	13,230	7,940	*8,820	5,290	*5,510	4,850		
	2 sets stab down (Load over front)	kg	*12 600	*12 600	*8400	*8100	*6100	5300	*4000	3500	*2500	*2500	
	lb	*27,780	*27,780	*18,520	*17,860	*13,450	11,680	*8,820	7,720	*5,510	*5,510		
Dozer and stab down (Load over front)	kg	*12 600	*12 600	*8400	7100	*6100	4500	*4000	3000	*2500	*2500		
lb	*27,780	*27,780	*18,520	15,650	*13,450	9,920	*8,820	6,610	*5,510	*5,510			
-1.5 m (-5.0 ft)	Rear dozer up (Load over front)	kg	13 500	7000	6800	3900	4100	2400			*2800	1600	
	lb	29,760	15,430	14,990	8,600	9,040	5,290				*6,170	3,530	
	Rear dozer down (Load over rear)	kg	*13 700	8400	*8600	4500	*6000	2700			*2800	1900	
	lb	*30,200	18,520	*18,960	9,920	*13,230	5,950				*6,170	4,190	
	Rear stab down (Load over rear)	kg	*13 700	10 900	*8600	5600	5900	3400			*2800	2400	
	lb	*30,200	24,030	*18,960	12,350	13,010	7,500				*6,170	5,290	
	2 sets stab down (Load over front)	kg	*13 700	*13 700	*8600	*8400	*6000	5100			*2800	*2800	
	lb	*30,200	*30,200	*18,960	*18,520	*13,230	11,240				*6,170	*6,170	
Dozer and stab down (Load over front)	kg	*13 700	*13 700	*8600	7000	*6000	4300			*2800	*2800		
lb	*30,200	*30,200	*18,960	15,430	*13,230	9,480				*6,170	*6,170		
-3.0 m (-10.0 ft)	Rear dozer up (Load over front)	kg	13 800	7100	6500	3600							
	lb	30,420	15,650	14,330	7,940								
	Rear dozer down (Load over rear)	kg	*14 000	8500	*7900	4300							
	lb	*30,870	18,740	*17,420	9,480								
	Rear stab down (Load over rear)	kg	*14 000	10 900	*7900	5300							
	lb	*30,870	24,030	*17,420	11,680								
	2 sets stab down (Load over front)	kg	*14 000	*14 000	*7900	*7900							
	lb	*30,870	*30,870	*17,420	*17,420								
Dozer and stab down (Load over front)	kg	*14 000	*14 000	*7900	6700								
lb	*30,870	*30,870	*17,420	14,770									

\* Indicates that the load is limited by hydraulic capacity rather than tipping capacity. Lift capacity ratings are based on SAE standard JISO 10567. Rated loads do not exceed 87% of hydraulic lifting capacity or 75% of tipping load.

- All lift capacities are calculated with Heavy Lift on.
- Oscillating axle must be locked.
- All values are calculated at the stick-nose.

# Offset Boom – 2.4 m (7'10") stick

Stick  
2.4 m (7'10")



Load Point  
Height



Load Radius  
Over Front  
or Rear



Load Radius  
Over Side

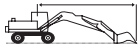

Load at  
Maximum Reach











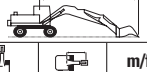



Stick 2.4 m (7'10")	Undercarriage configuration		3.0 m (10.0 ft)		4.5 m (15.0 ft)		6.0 m (20.0 ft)		7.5 m (25.0 ft)		m/ft		
6.0 m (20.0 ft)	Rear dozer up (Load over front)	kg			*4800	4600	4600	2800					
	Rear dozer down (Load over rear)	kg			*4800	*4800	*4700	3200					
	Rear stab down (Load over rear)	kg			*10,580	*10,580	*10,360	7,060					
	2 sets stab down (Load over front)	kg			*4800	*4800	*4700	3900					
	Dozer and stab down (Load over front)	kg			*10,580	*10,580	*10,360	8,600					
		lb			*10,580	*10,580	*10,360	*4700					
		lb			*10,580	*10,580	*10,360	*10,360					
		lb			*10,580	*10,580	*10,360	*10,360					
4.5 m (15.0 ft)	Rear dozer up (Load over front)	kg	*5300	*5300	4500	4600	2900	*2800	1700	*2000	1600		
	Rear dozer down (Load over rear)	kg	*11,680	*11,680	*12,570	9,920	10,140	6,390	*6,170	3,750	*4,410	3,530	
	Rear stab down (Load over rear)	kg	*5300	*5300	*5700	5100	*5100	3300	*2800	2000	*2000	1900	
	2 sets stab down (Load over front)	kg	*11,680	*11,680	*12,570	11,240	*11,240	7,280	*6,170	4,410	*4,410	4,190	
	Dozer and stab down (Load over front)	kg	*5300	*5300	*5700	5900	*5100	*3900	*2800	2500	*2000	*2000	
		lb	*11,680	*11,680	*12,570	*12,570	*11,240	*8,600	*6,170	5,510	*4,410	*4,410	4,410
		lb	*11,680	*11,680	*12,570	*12,570	*11,240	*11,240	*6,170	*6,170	*4,410	*4,410	4,410
		lb	*5300	*5300	*5700	5700	*5100	4700	*2800	*2800	*2000	*2000	2000
3.0 m (10.0 ft)	Rear dozer up (Load over front)	kg	*8600	7900	6900	4300	4500	2900	3000	1700	*2000	1400	
	Rear dozer down (Load over rear)	kg	*18,960	17,420	15,210	9,480	9,920	6,390	6,610	3,750	*4,410	3,090	
	Rear stab down (Load over rear)	kg	*8600	*8600	*7300	5000	*5500	3300	*4500	2000	*2000	1700	
	2 sets stab down (Load over front)	kg	*18,960	*18,960	*16,090	11,020	*12,130	7,280	*9,920	4,410	*4,410	3,750	
	Dozer and stab down (Load over front)	kg	*18,960	*18,960	*16,090	13,010	*12,130	*8,600	*9,920	5,510	*4,410	*4,410	
		lb	*18,960	*18,960	*16,090	*16,090	*12,130	11,910	*9,920	8,160	*4,410	*4,410	4,410
		lb	*8600	*8600	*7300	7100	*5500	4600	*4500	3100	*2000	*2000	2000
		lb	*18,960	*18,960	*16,090	15,650	*12,130	10,140	*9,920	6,830	*4,410	*4,410	4,410
1.5 m (5.0 ft)	Rear dozer up (Load over front)	kg	*10,400	7600	6800	4300	4500	2900	3000	1700	*2100	1300	
	Rear dozer down (Load over rear)	kg	*22,930	16,760	14,990	9,480	9,920	6,170	6,610	3,750	*4,630	2,870	
	Rear stab down (Load over rear)	kg	*10,400	8800	*8200	4900	*5900	3200	*4700	2000	*2100	1600	
	2 sets stab down (Load over front)	kg	*22,930	19,400	*18,080	10,800	*13,010	7,060	*10,360	4,410	*4,630	3,530	
	Dozer and stab down (Load over front)	kg	*22,930	*22,930	*18,080	12,790	*13,010	8,600	*9,920	5,510	*4,630	4,410	
		lb	*22,930	*22,930	*18,080	*17,640	*13,010	*11,680	*10,360	8,160	*4,630	*4,630	4,630
		lb	*10,400	*10,400	*8200	5800	*5900	3900	4100	2500	*2100	2000	2000
		lb	*22,930	*22,930	*18,080	6900	*5900	4600	*4700	3100	*2100	*2100	2100
Ground	Rear dozer up (Load over front)	kg	*12,200	7400	6800	4100	4400	2900	1600	*2200	1500		
	Rear dozer down (Load over rear)	kg	*26,900	16,310	14,990	9,040	9,700	5,730	6,390	3,530	*4,850	3,090	
	Rear stab down (Load over rear)	kg	*12,200	8800	*8300	4700	*6000	3000	*4500	1900	*2200	1600	
	2 sets stab down (Load over front)	kg	*26,900	19,400	*18,300	10,360	*13,230	6,610	*9,920	4,190	*4,850	3,530	
	Dozer and stab down (Load over front)	kg	*26,900	24,030	*18,300	12,790	13,010	8,160	8,820	5,290	*4,850	4,410	
		lb	*26,900	*26,900	*18,300	*17,860	*13,230	11,680	*9,920	7,490	*4,850	*4,850	4,850
		lb	*12,200	*12,200	*8300	5800	*6000	3700	4000	2400	*2200	2000	2000
		lb	*26,900	*26,900	*18,300	7000	*6000	4500	*4500	3000	*2200	*2200	2200
-1.5 m (-5.0 ft)	Rear dozer up (Load over front)	kg	13,300	7000	6500	3700	4000	2300			*2500	1500	
	Rear dozer down (Load over rear)	kg	29,320	15,430	14,990	8,600	9,260	5,290			*5,510	3,310	
	Rear stab down (Load over rear)	kg	*13,600	8400	*8500	4500	*6100	2800			*2500	1800	
	2 sets stab down (Load over front)	kg	*29,980	18,520	*18,740	9,920	*13,450	6,170			*5,510	3,970	
	Dozer and stab down (Load over front)	kg	*29,980	24,030	*18,740	12,350	13,010	7,720			*5,510	5,070	
		lb	*29,980	*29,980	*18,740	*18,300	*13,450	11,240			*5,510	*5,510	5,510
		lb	*13,600	13,500	*8500	7000	*6100	4300			*2500	*2500	2500
		lb	*29,980	29,760	*18,740	15,430	*13,450	9,480			*5,510	*5,510	5,510
-3.0 m (-10.0 ft)	Rear dozer up (Load over front)	kg	13,700	7000	6500	3700	4000	2300					
	Rear dozer down (Load over rear)	kg	30,200	15,430	14,330	8,160	8,820	5,070					
	Rear stab down (Load over rear)	kg	*14,100	8400	*8400	4300	*4300	2700					
	2 sets stab down (Load over front)	kg	*31,090	18,520	*18,520	9,480	*9,480	5,950					
	Dozer and stab down (Load over front)	kg	*31,090	23,810	*18,520	11,910	*9,480	7,280					
		lb	*14,100	*14,100	*8400	8200	*4300	*4300					
		lb	*31,090	*31,090	*18,520	18,080	*9,480	*9,480					
		lb	*14,100	*14,100	*8400	6700	*4300	4200					

\* Indicates that the load is limited by hydraulic capacity rather than tipping capacity. Lift capacity ratings are based on SAE standard JISO 10567. Rated loads do not exceed 87% of hydraulic lifting capacity or 75% of tipping load.

- All lift capacities are calculated with Heavy Lift on.
- Oscillating axle must be locked.
- All values are calculated at the stick-nose.

# VA Boom Industrial Stick – 3.1 m (10'2") stick

**Stick**  
3.1 m (10'2")



Stick 3.1 m (10'2")		Undercarriage configuration	3.0 m (10.0 ft)		4.5 m (15.0 ft)		6.0 m (20.0 ft)		7.5 m (25.0 ft)							
													m/ft			
			kg	lb	kg	lb	kg	lb	kg	lb	kg	lb				
 Load Point Height	6.0 m (20.0 ft)	Rear dozer up (Load over front)					*4600									
		Rear dozer down (Load over rear)					*10,140	3700								
		Rear stab down (Load over rear)					*4600	8,160								
		2 sets stab down (Load over front)					*10,140	4400								
		Dozer and stab down (Load over front)					*4600	9,700								
							*4600	*4600								
							*10,140	*10,140								
 Load Radius Over Front or Rear	4.5 m (15.0 ft)	Rear dozer up (Load over front)			*5100	4900	5000	3300	3600	2300	*3200	2100	7.89 m (25'11")			
		Rear dozer down (Load over rear)			*11,240	10,800	11,020	7,280	7,940	5,070	*7,060	4,630				
		Rear stab down (Load over rear)			*5100	5100	*5200	3700	*4200	2600	*3200	2400				
		2 sets stab down (Load over front)			*11,240	11,240	*11,460	8,160	*9,260	5,730	*7,060	5,290				
		Dozer and stab down (Load over front)			*5100	5100	*5200	4400	*4200	3100	*3200	2800				
						*11,240	11,240	*11,460	9,700	*9,260	6,830	*7,060		6,170		
						*5100	*5100	*5200	*4200	*4200	*4200	*3200		*3200		
 Load Radius Over Side	3.0 m (10.0 ft)	Rear dozer up (Load over front)			*8800	8400	4700	3300	3600	2300	*3200	1900	8.27 m (27'2")			
		Rear dozer down (Load over rear)			*19,400	18,520	16,310	10,360	11,800	7,280	7,940	5,070		6,610	4,190	
		Rear stab down (Load over rear)			*8800	*8800	*7500	5400	*5900	3700	*4900	2600		*3200	2200	
		2 sets stab down (Load over front)			*19,400	*19,400	*16,540	11,910	*13,010	8,160	*10,800	5,730		*7,060	4,850	
		Dozer and stab down (Load over front)			*8800	*8800	*7500	6400	*5900	4300	4700	3100		*3200	2600	
						*19,400	*19,400	*16,540	14,110	*13,010	9,480	10,360		6,830	*7,060	5,730
						*8800	*8800	*7500	*7500	*5900	5100	*4900		3700	*3200	3100
 Load at Maximum Reach	1.5 m (5.0 ft)	Rear dozer up (Load over front)			*11 600	8200	7300	4700	3200	3500	2200	3000	1900	8.36 m (27'5")		
		Rear dozer down (Load over rear)			*25,570	10,080	16,090	10,360	10,800	7,060	7,720	4,850	6,390		4,190	
		Rear stab down (Load over rear)			*11 600	9400	*8700	5300	*6400	3700	*5200	2500	*3400		2100	
		2 sets stab down (Load over front)			*25,570	20,720	*19,180	11,680	*14,110	8,160	*11,460	5,100	*7,500		4,630	
		Dozer and stab down (Load over front)			*11 600	*11 600	*8700	6300	*6400	4300	4600	3000	*3400		2500	
						*25,570	*25,570	*19,180	13,890	*14,110	9,480	10,140	6,610		*7,500	5,510
						*11 600	*25,570	*19,180	19,180	*14,110	12,790	*11,460	*9,260		*7,500	*7,500
Ground		Rear dozer up (Load over front)			*12 800	8100	7300	4600	3100	3400	2200	3000	1900	8.17 m (26'10")		
		Rear dozer down (Load over rear)			*28,220	17,860	16,090	10,140	10,800	6,830	7,500	4,850	6,610		4,190	
		Rear stab down (Load over rear)			*12 800	9400	*9100	5300	*6700	3500	5200	2400	*3700		2100	
		2 sets stab down (Load over front)			*28,220	20,720	*20,060	11,680	*14,770	7,720	11,460	5,290	*8,160		4,630	
		Dozer and stab down (Load over front)			*12 800	11 500	*9100	6300	*6700	4200	4600	2900	*3700		2600	
						*28,220	25,350	*20,060	13,890	*14,770	9,260	10,140	6,390		*8,160	5,730
						*12 800	*28,220	*20,060	19,180	*14,770	12,790	*11,680	9,040		*8,160	7,940
-1.5 m (-5.0 ft)		Rear dozer up (Load over front)			14 000	7800	7300	4400	2900	3300	2100	3200	2000	7.66 m (25'2")		
		Rear dozer down (Load over rear)			30,870	17,200	16,090	9,700	10,360	6,390	7,280	4,630	7,060		4,410	
		Rear stab down (Load over rear)			*14 400	9100	*9200	5100	*6700	3300	*4800	2400	*4300		2300	
		2 sets stab down (Load over front)			*31,750	20,060	*20,280	11,240	*14,770	7,280	*10,580	5,290	*9,480		5,070	
		Dozer and stab down (Load over front)			*14 400	11 600	*9200	6100	6400	4000	4500	2800	*4300		2800	
						*31,750	25,570	*20,280	13,450	14,110	8,820	9,920	6,170		*9,480	6,170
						*14 400	*31,750	*20,280	19,400	*14,770	12,570	*10,580	8,820		*9,480	8,600
-3.0 m (-10.0 ft)		Rear dozer up (Load over front)			14 200	7600	7100	4300	2900	3300	2100	2800	2000			
		Rear dozer down (Load over rear)			31,310	16,760	15,650	9,480	10,140	6,170						
		Rear stab down (Load over rear)			*14 700	9000	*9400	4900	*6200	3200						
		2 sets stab down (Load over front)			*32,410	19,840	*20,720	10,800	*13,670	7,060						
		Dozer and stab down (Load over front)			*14 700	11 400	*9400	5900	*6200	3900						
						*32,410	25,130	*20,720	13,010	*13,670	8,600					
						*14 700	*32,410	*20,720	19,400	*13,670	12,130					
-4.5 m (-15.0 ft)		Rear dozer up (Load over front)			*12 000	7500	*6000	4100								
		Rear dozer down (Load over rear)			*26,460	16,540	*13,230	9,040								
		Rear stab down (Load over rear)			*12 000	8800	*6000	4700								
		2 sets stab down (Load over front)			*26,460	19,400	*13,230	10,360								
		Dozer and stab down (Load over front)			*12 000	11 300	*6000	5800								
						*26,460	24,910	*13,230	12,790							
						*12 000	*12 000	*6000	*6000							

\* Indicates that the load is limited by hydraulic capacity rather than tipping capacity. Lift capacity ratings are based on SAE standard JISO 10567. Rated loads do not exceed 87% of hydraulic lifting capacity or 75% of tipping load.

- All lift capacities are calculated with Heavy Lift on.
- Oscillating axle must be locked.
- All values are calculated at the stick-nose.

# One-piece Boom Industrial Stick – 3.1 m (10'2") stick

Stick  
3.1 m (10'2")

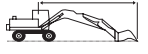
Stick 3.1 m (10'2")	Undercarriage configuration	3.0 m (10.0 ft)		4.5 m (15.0 ft)		6.0 m (20.0 ft)		7.5 m (25.0 ft)		m/ft			
		Front	Rear	Front	Rear	Front	Rear	Front	Rear	Front	Rear		
		kg	lb	kg	lb	kg	lb	kg	lb	kg	lb		
 Load Point Height  Load Radius Over Front or Rear  Load Radius Over Side  Load at Maximum Reach	6.0 m (20.0 ft)	Rear dozer up (Load over front)	kg				*4500	3300					
		Rear dozer down (Load over front)	kg				*9,920	7,280					
		Rear dozer up (Load over rear)	kg				*4500	3700					
		Rear dozer down (Load over rear)	kg				*9,920	8,160					
		Rear stab down (Load over rear)	kg				*4500	4300					
		2 sets stab down (Load over front)	kg				*9,920	9,480					
		2 sets stab down (Load over rear)	kg				*4500	*4500					
		Dozer and stab down (Load over front)	kg				*9,920	*9,920					
4.5 m (15.0 ft)	Rear dozer up (Load over front)	kg				5000	3200	3600	2300	*3200	2200		
	Rear dozer down (Load over front)	kg				11,020	7,060	7,940	5,070	*7,060	4,850		
	Rear dozer up (Load over rear)	kg				*5200	3600	*3600	2600	*3200	2500		
	Rear dozer down (Load over rear)	kg				*11,460	7,940	*7,940	5,730	*7,060	5,510		
	Rear stab down (Load over rear)	kg				*5200	4300	*3600	3100	*3200	3000		
	2 sets stab down (Load over front)	kg				*11,460	9,480	*7,940	6,830	*7,060	6,610		
	2 sets stab down (Load over rear)	kg				*5200	*5200	*3600	*3600	*3200	*3200		
	Dozer and stab down (Load over front)	kg				*11,460	*11,460	*7,940	*7,940	*7,060	*7,060		
3.0 m (10.0 ft)	Rear dozer up (Load over front)	kg				*7200	4600	3100	3500	2300	*3200	2100	
	Rear dozer down (Load over front)	kg				*15,870	10,140	10,580	6,830	7,720	5,070	*7,060	4,630
	Rear dozer up (Load over rear)	kg				*7200	5200	*5800	3500	*4800	2500	*3200	2300
	Rear dozer down (Load over rear)	kg				*15,870	11,460	*12,790	7,720	*10,580	5,510	*7,060	5,070
	Rear stab down (Load over rear)	kg				*7200	6300	*5800	4100	4600	3000	*3200	2700
	2 sets stab down (Load over front)	kg				*15,870	13,890	*12,790	9,040	10,140	6,610	*7,060	5,950
	2 sets stab down (Load over rear)	kg				*7200	*7200	*5800	*5800	*4800	4200	*3200	*3200
	Dozer and stab down (Load over front)	kg				*15,870	*15,870	*12,790	*12,790	*10,580	9,260	*7,060	*7,060
1.5 m (5.0 ft)	Rear dozer up (Load over front)	kg				7100	4300	4700	3000	3400	2200	3100	2000
	Rear dozer down (Load over front)	kg				15,650	9,480	10,360	6,610	7,500	4,850	6,830	4,410
	Rear dozer up (Load over rear)	kg				*8600	4900	*6400	3300	5200	2500	*3400	2200
	Rear dozer down (Load over rear)	kg				*18,960	10,800	*14,110	7,280	11,460	5,510	*7,500	4,850
	Rear stab down (Load over rear)	kg				*8600	6000	*6400	4000	4600	3000	*3400	2600
	2 sets stab down (Load over front)	kg				*18,960	13,230	*14,110	8,820	10,140	6,610	*7,500	5,730
	2 sets stab down (Load over rear)	kg				*8600	*8600	*6400	5600	*5300	4100	*3400	*3400
	Dozer and stab down (Load over front)	kg				*18,960	*18,960	*14,110	12,350	*11,680	9,040	*7,500	*7,500
Ground	Rear dozer up (Load over front)	kg				*5800	*5800	6800	4100	4600	2900	3400	2000
	Rear dozer down (Load over front)	kg				*12,790	*12,790	14,990	9,040	10,140	6,390	7,500	4,850
	Rear dozer up (Load over rear)	kg				*5800	*5800	*9300	4700	*6800	3200	5100	2400
	Rear dozer down (Load over rear)	kg				*12,790	*12,790	*20,500	10,360	*14,990	7,060	11,240	5,290
	Rear stab down (Load over rear)	kg				*5800	*5800	*9300	5700	6200	3900	4500	2900
	2 sets stab down (Load over front)	kg				*12,790	*12,790	*20,500	12,570	13,670	8,600	9,920	6,390
	2 sets stab down (Load over rear)	kg				*5800	*5800	*9300	8500	*6800	5500	*5300	4100
	Dozer and stab down (Load over front)	kg				*12,790	*12,790	*20,500	18,740	*14,990	12,130	*11,680	9,040
-1.5 m (-5.0 ft)	Rear dozer up (Load over front)	kg				*8600	7100	6700	4000	4500	2800	3400	2200
	Rear dozer down (Load over front)	kg				*18,960	15,650	14,770	8,820	9,920	6,170	7,500	4,850
	Rear dozer up (Load over rear)	kg				*8600	8300	*9000	4600	*6600	3200	*4600	2400
	Rear dozer down (Load over rear)	kg				*18,960	18,300	*19,840	10,140	*14,550	7,060	*10,140	5,290
	Rear stab down (Load over rear)	kg				*8600	*8600	*9000	5600	6200	3800	*4600	2900
	2 sets stab down (Load over front)	kg				*18,960	*18,960	*19,840	12,350	13,670	8,380	*10,140	6,390
	2 sets stab down (Load over rear)	kg				*8600	*8600	*9000	8400	*6600	5500	*4600	4100
	Dozer and stab down (Load over front)	kg				*18,960	*18,960	*19,840	18,520	*14,550	12,130	*10,140	9,040
-3.0 m (-10.0 ft)	Rear dozer up (Load over front)	kg				*11,000	7100	6800	4000	4500	2800	3400	2200
	Rear dozer down (Load over front)	kg				*24,250	15,650	14,990	8,820	9,920	6,170	7,500	4,850
	Rear dozer up (Load over rear)	kg				*11,000	8400	*7800	4600	*5600	3200	*4600	2400
	Rear dozer down (Load over rear)	kg				*24,250	18,520	*17,200	10,140	*12,350	7,060	*10,140	5,290
	Rear stab down (Load over rear)	kg				*11,000	10,700	*7800	5600	*5600	3800	*4600	2900
	2 sets stab down (Load over front)	kg				*24,250	23,590	*17,200	12,350	*12,350	8,380	*10,140	6,390
	2 sets stab down (Load over rear)	kg				*11,000	*11,000	*7800	*7800	*5600	5500	*4600	4100
	Dozer and stab down (Load over front)	kg				*24,250	*24,250	*17,200	*17,200	*12,350	12,130	*10,140	9,040
-4.5 m (-15.0 ft)	Rear dozer up (Load over front)	kg				*7100	*7100	*5000	4100				
	Rear dozer down (Load over front)	kg				*15,650	*15,650	*11,020	9,040				
	Rear dozer up (Load over rear)	kg				*7100	*7100	*5000	4700				
	Rear dozer down (Load over rear)	kg				*15,650	*15,650	*11,020	10,360				
	Rear stab down (Load over rear)	kg				*7100	*7100	*5000	5000				
	2 sets stab down (Load over front)	kg				*15,650	*15,650	*11,020	*11,020				
	2 sets stab down (Load over rear)	kg				*7100	*7100	*5000	5000				
	Dozer and stab down (Load over front)	kg				*15,650	*15,650	*11,020	*11,020				

\* Indicates that the load is limited by hydraulic capacity rather than tipping capacity. Lift capacity ratings are based on SAE standard JISO 10567. Rated loads do not exceed 87% of hydraulic lifting capacity or 75% of tipping load.

- All lift capacities are calculated with Heavy Lift on.
- Oscillating axle must be locked.
- All values are calculated at the stick-nose.

## Standard Equipment

*Standard equipment may vary. Consult your Caterpillar dealer for details.*

### Operator Station

- Adjustable armrests
- Ash tray with cigarette lighter (24 volt)
- Beverage cup/can holder
- Bolt-on FOGS capability
- Bottle holder
- Coat hook
- Floor mat, washable, with storage compartment
- Fully adjustable suspension seat
- Heater and defroster
- Joysticks
- Laminated front windshield
- Left side console, tiltable, with lock out for all controls
- Literature compartment behind seat
- Literature holder in right console
- Mobile phone holder
- Monitor and gauges with full color graphical display
  - Information and warning messages in local language
  - Gauges for fuel level, engine coolant and hydraulic oil temperature
  - Filters/fluids change interval, working hour
  - Indicators for headlights, turning signal, low fuel, engine dial setting
  - Clock with 10 day backup battery
- Parking brake
- Parallel mounted top and bottom wiper and washer
- Positive filtered ventilation, pressurized cab
- Power supply, 12V-7A
- Rear window, emergency exit
- Retractable seat belt
- Seat with adjustable mechanical suspension
- Skylight
- Sliding door windows
- Steering column, tiltable
- Storage area suitable for a lunch box
- Sunshade for windshield and skylight

### Electrical

- Alternator, 75amp
- Lights
  - Boom working light
  - Cab interior
  - Roading lights (two front, two rear)
- Maintenance free batteries
- Main shut-off switch
- Signal/warning horn

### Engine

- Automatic engine speed control
- Automatic starting aid
- Cat C6.6 with ACERT™ Technology U.S. EPA Tier 3
- Fuel filter
- Fuel/water separator with level indicator
- Muffler

### Hydraulics

- Cat XT™-6 ES hoses
- Heavy lift mode
- Load-Sensing Plus hydraulic system
- Manual work modes (economy, power)
- Oil cooler
- Separate swing pump
- Stick regeneration circuit

### Undercarriage

- Heavy-Duty axles with advanced travel motor with adjustable braking force
- Oscillating front axle with remote greasing
- Pin-on design preparation for dozer blade and outriggers
- Tires, 10.00-20 16PR, dual
- Tool box in undercarriage
- Two-piece drive shaft
- Two-speed transmission with manual and automatic gear shifting
- Undercarriage storage box

### Other Equipment

- Automatic swing brake
- Caterpillar Datalink and Electronic Technician capability
- Caterpillar Product Link
- Counterweight 3700 kg (8157 lb)
- Door locks and caps locks with Caterpillar one-key security system
- Mirrors, frame and cab
- S•O•S<sup>SM</sup> quick sampling valves for engine oil, hydraulic oil and coolant



## Optional Equipment

*Optional equipment may vary. Consult your Caterpillar dealer for details.*

### Auxiliary Controls and Lines

- Auxiliary boom and stick lines
- Anti-drift valves for bucket, stick, VA Boom and tool control/multi-function circuits

#### Basic control circuits:

##### Single action

- One-way, high pressure circuit, for hammering application

##### Medium pressure

- Two-way, medium pressure circuit, for rotating or tilting of work tools

##### Tool control/multi function

- One/two-way high pressure for hammer application or opening and closing of a work tool

- Programmable flow and pressure for up to 10 work tools – selection via monitor

##### Second high pressure

- Additional two-way, high pressure circuit, for tools requiring a second high or medium pressure function

##### Quick coupler control

- Biodegradable hydraulic oil (synthetic ester based)

- Generator with valve and priority function

- Lowering control devices for boom and stick

### Front Linkage

#### Booms

- One-piece boom, 5.05 m (16 ft 6 in)

- Offset boom, 5.2m (17 ft 1 in)

- Variable adjustable boom (two piece), 5.20 m (17 ft 1 in)

- Bucket linkage with diverter valve

#### Sticks

- 2.1 m (6 ft 11 in) stick

- 2.4 m (7 ft 10 in) stick

- 2.6 m (8 ft 6 in) stick

- 3.1 m (10 ft 2 in) Industrial stick with drop nose

### Electrical

- Back-up alarm with three selectable modes

- Heavy-duty maintenance free batteries

- Refueling pump

- Rooding lights, rear consisting of long life LED modules

- Rotating beacon on cab

- Working lights, cab mounted (front and rear)

### Operator Station

- Adjustable hydraulic sensitivity

- Air conditioner, heater and defroster with automatic climate control

- Camera mounted on counterweight, displays through cab monitor

- Falling objects guard

- Fixed cab riser 1200 mm (4 ft)

- Lid for storage compartment

#### Radio

- Radio, AM/FM stereo (24V)

- Radio ready mounting (12 V or 24 V) at rear location including speakers and 12 V converter

#### Seat

- Adjustable high-back seat with mechanical suspension

- Adjustable high-back seat with air suspension (vertical)

- Adjustable high-back deluxe seat with headrest, air suspension (horizontal and vertical), two-step seat heater, automatic weight adjustments, ventilated seat cushions, pneumatically adjustable lumbar support

#### Headrest

- Travel speed lock

- Vandalism guards

- Visor for rain protection

#### Windshield

- One-piece high impact resistant

- 50/50 split, openable

- 70/30 split, openable

#### Undercarriage

- Dozer blade, front and/or rear mounted, with remote greasing

#### Optional tires

##### Dual tires

- 11.00-20 dual tires

- 10.00-20 dual solid rubber

##### Single tires

- 18-R 19.5 XF single

- 600/40-22.5 single

- Outriggers, front and/or rear mounted

- Second tool box for undercarriage

- Spacer rings for tires

- Wide axles

#### Other Equipment

- Auto-lube system for the implements and swing gear

- Cat Machine Security System

- Counterweight 4100 kg (9039 lb)

- Custom paint

- Heated mirrors, frame and cab

- Joystick steering

- Enables steering of the machine in first gear using the sliding switch on joystick

- Lockable tool box in upper frame

- Ride control, for increased comfort while traveling and working

- Waste package with cyclone air pre-cleaner, reversible fan with programmable time





# M316D Wheel Excavator

For more complete information on Cat products, dealer services,  
and industry solutions, visit us on the web at [www.cat.com](http://www.cat.com)

© 2006 Caterpillar  
All Rights Reserved  
Printed in U.S.A.

Materials and specifications are subject to change without notice.  
Featured machines in photos may include additional equipment.  
See your Caterpillar dealer for available options.

CAT, CATERPILLAR, ACERT, HEES, their respective logos, "Caterpillar Yellow" and the  
POWER EDGE trade dress, as well as corporate and product identity used herein,  
are trademarks of Caterpillar and may not be used without permission.

AEHQ5755 (12-06)

**CATERPILLAR**<sup>®</sup>