

**VOLVO WHEEL LOADER**

# **L150E**



**VOLVO**

# L150E - A RELIABLE PARTNER IN WHATEVER YOU DO

Wheel loaders are required to work long shifts, day after day, year after year. The L150E gets the job done with maximum efficiency and minimum impact on the operator and environment. The 25-ton L150E reinforces Volvo's reputation of producing reliable equipment that will withstand the conditions of heavy-duty work. The L150E - built to endure long shifts for years to come.

The Volvo L150E is a lively machine. The high performance, low emission engine delivers close to maximum power already at low rpm. Furthermore, the powerful patented TP linkage, combined with Volvo's purpose-built range of attachments, provides the flexibility needed to handle a variety of tasks. Jobs at which the L150E excels include loading trucks, feeding a crusher, earthmoving and timber handling. Advanced technology helps to make this a swift, versatile and fuel efficient production machine. In fact, we're convinced you're looking at the champion in the 25-ton class.

## Get more done

You'll find the L150E a pleasure to operate. In this respect, competing loaders simply can't compete. It's powerful, agile and easy to maneuver. Sitting comfortably in an ergonomically designed seat, you have total control

over the machine. Engine and hydraulics respond immediately to your commands. Visibility is panoramic and the air in the cab is always fresh. Both operator and machine get more done with a lot less haste.

## A great deal for your investment

Proven reliability, excellent financing, extremely low fuel consumption and a high trade-in value provide the cornerstones of a safe investment. Add to that outstanding handling and productivity, a market-leading operator environment to protect the person in the machine, quick and simple daily maintenance and modest service requirements. And what do you get? The most cost efficient loader in its class, delivering unparalleled profitability - both now and in years to come.

With the L150E, everybody is a winner. Quite simply, a great deal for your money.



## Specifications L150E

Engine:	Volvo D9A LB E2
Max power at	26,7 r/s (1600 r/min)
SAE J1995 gross:	211 kW (287 hp)
ISO 9249, SAE J1349 net:	210 kW (284 hp)
Breakout force:	178,1 kN*
Static tipping load at full turn:	15 290 kg*
Buckets:	3,1 - 12,0 m <sup>3</sup>
Log grapples:	1,6 - 3,5 m <sup>2</sup>
Operating weight:	23,0 - 26,0 t
Tires:	26.5 R25 775/65 R29

\* Bucket: 4,0 m<sup>3</sup> with bolt-on edges, tires 26.5 R25 L3, standard boom



# POWER UP YOUR PRODUCTIVITY

Load more tons per hour with the Volvo L150E. Its powerful engine and the fully Automatic Power Shift (APS) gear shifting system provide immediate response even in the toughest conditions. And Volvo axles are designed to ensure that the rimpull is there when needed. Torque Parallel linkage (TP linkage), load-sensing hydraulics, smooth steering and stable operation help make the L150E a precision performer.

## **The only thing modest about this machine is its fuel consumption**

Even at low rpm, the 12-liter high performance engine delivers full power and maximum torque. The machine responds quickly and forcefully with excellent rimpull, full hydraulic power, low fuel consumption and low emissions. And thanks to the low rpm performance, the service life of the engine is extended.

## **Responds to your commands**

The Volvo fully automatic countershaft transmission provides smooth and effective gear shifting. All the operator has to do is select forward or reverse and APS automatically selects the right gear according to both engine rpm and ground speed. Volvo's in-house engineered axles and drivetrain are well matched and designed for top dependability. And Volvo's oil circulation cooled wet disc brakes provide smooth, effective braking – and, of course, a long service life.

## **Torque Parallel linkage – a breakthrough in the industry**

The reliable TP linkage, Volvo's patented lift-arm system, delivers high and even breakout torque throughout the entire lifting range. The system is exceedingly user-friendly. The operator can easily handle heavy materials and maintain full control in all positions.

## **Hydraulics that make sense**

The Volvo L150E features an intelligent load sensing system for both the main and steering hydraulics. Two variable piston pumps provide the exact flow and pressure required at any given moment, distributing power when and where it's needed. In addition to rapid response, this system facilitates smoother operation, lower fuel consumption, and precise control, even at low rpm.

## **Engine**

- Volvo D9A, a turbocharged, air-to-air intercooled low emission engine with electronically controlled fuel injection, delivers high torque even at low rpm.
- The electronically controlled hydrostatic fan is only activated when necessary, thus saving fuel.

## **Transmission**

- With Volvo's 3rd generation of APS, the operator can select between four different operating modes, including the new AUTO function, which adaptively chooses the most convenient shifting program for the job at hand, equally weighing the operator's driving habits together with the operating cycle.
- The 3rd generation APS now has fully automatic shifting 1-4, meaning all the operator has to do is choose forward or reverse.

## **Axles/Brakes**

- The Volvo axles are fully integrated with the drivetrain, delivering superior rimpull.
- Oil circulation cooled wet disc brakes ensure effective braking and a long service life.
- An electronic brake test in Contronic gives you instant access to the status of the brakes.
- A brake wear indicator on each wheel allows you to easily check the brake pad wear.

## **Steering**

- Load-sensing steering only uses power when it's needed, thereby saving fuel.
- E-series loaders feature an accumulator system, providing stable, smooth steering and greater safety.

## **Frame**

- Rugged frame design for secure mounting of components increases the service life of the machine.
- Volvo's frame joint bearing design is a well-proven concept that's easy to maintain and renowned for its long service life.



#### **TP linkage**

- Unique patented lift-arm system, which provides two solutions in one: excellent breakout torque and parallel action throughout the entire lifting range.

#### **Load-sensing hydraulics**

- The load-sensing hydraulic system ensures that hydraulic oil is pumped around the system only when and where it's needed. This means greater efficiency and lower fuel consumption.
- Pilot-operated hydraulics allow precise control of the attachments, making life easier, and safer, for the operator.

# AN ALERT OPERATOR IS A PRODUCTIVE OPERATOR

Volvo Care Cab with the Contronic monitoring system reinforces Volvo's reputation as a leader in operator environments and cab comfort. We never forget the operator inside the machine. A comfortable, operator-friendly and safe environment makes the workday easier and more productive.



## **A clean and comfortable workplace**

The right cab climate does wonders for efficiency, keeping operators sharp during long shifts. In fact, all incoming air is filtered in two stages, making this one of the cleanest cabs on the market. Even the recirculated air is filtered.

Furthermore, Volvo's state-of-the-art air-conditioning\* provides a pleasant temperature year-round, regardless of outdoor conditions. So even after a long work shift, the air in the cab is still fresh and the operator's mind is still clear.

## **Comfort and productivity go hand-in-hand**

There is a range of comfortable seats, all of them with multiple adjustment functions for optimal individual comfort. All instruments are visible at a glance, and all important information is right in front of the operator. The forward, reverse and kick-down functions are situated both on the lever on the left-hand side of the steering wheel and on the hydraulic console to the right. And thanks to Comfort Drive Control (CDC)\*, you can steer, change directions and kickdown to first gear with easy-to-use controls integrated into the left-hand armrest – an excellent way to combat fatigue and static muscle strain. Furthermore, to avoid monotonous arm movements, you can shift at any time from lever steering to using the steering wheel.

## **Contronic keeps an eye on everything**

Contronic, the highly reliable control and monitoring system from Volvo, continuously monitors the machine's operation and performance. The system is an electronic network made up of three computers. Operating at three levels, the system keeps an eye on the machine's various functions in real-time. If a potential problem should occur, the system generates an immediate warning, making the operator aware of the condition. All operating data is saved and can be used to analyze how the machine performs and also to trace its history since the latest service. The machine's functions can be updated for optimal adaptation to new and changing operating conditions via the Contronic service display tool. With VCADS Pro, it's also possible to check and adjust the machine's functions and performance characteristics.

## **Low noise levels**

Thanks to the ingenious viscous cab mounts and heavy-duty insulation, the Care Cab is one of the quietest cabs on the market. By reducing tiresome earfuls and annoying vibrations, the operator will stay sharp throughout the shift. In short, it's a great place to work.

## **Care Cab**

- Unrivalled operator environment with one of the market's best cab filtration systems.
- Pleasant interior with superior finish makes it easy to maintain and keep clean.
- Adjustable seat, armrest, hydraulic lever console and steering wheel\* for optimal operator comfort and high production.
- Contronic, a superior control and monitoring system, designed to increase safety and productivity.
- All service platforms and entry ladders boast improved anti-slip surfaces. Sloped entry ladder for easy cab access.
- Standard viscous cab mounts feature a silicon fluid and rubber compound that work together to dampen cab vibrations and increase operator comfort.
- Large windscreens, narrow pillars and a sloped engine hood ensure good panoramic visibility, thus further increasing safety.
- Powerful halogen lighting to the front and rear provides good visibility over the entire work area.

\* Optional equipment

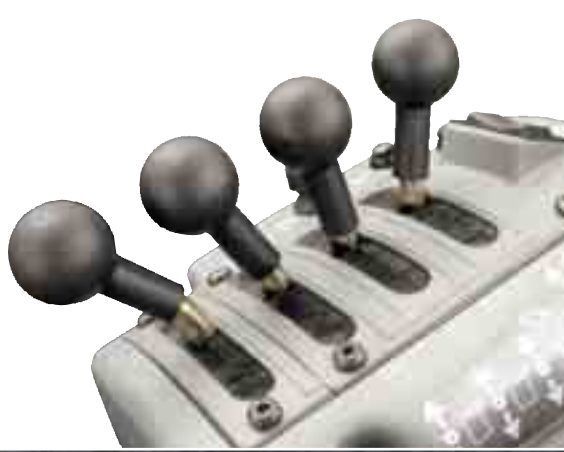

# VOLVO'S COMMITMENT TO NATURE AND MANKIND

Quality, safety, and care for the environment are Volvo's core values. Indeed, we see our commitment as an integral part of our operation. Few machines have to work in tougher conditions. The ultimate goal is maximized productivity and efficiency for the lowest cost per hour, with minimized environmental impact. For instance, plants and manufacturing processes are certified in accordance with ISO 14001. This is but one example of our tangible commitments and high quality standards. And that's why Volvo customers get one of the most environmentally considerate and dependable wheel loaders on the market.

## **A winner for years to come**

Your Volvo L150E has to be a winner – both in day-to-day and long-term operations, always operating economically with maximum consideration of the environment. The machinery has to be trusted in all aspects. It must deliver the anticipations of productivity and economy. High quality and easy maintenance are imperative for keeping up the work process. The high performance low emission engine is both good for your business and for the environment.

## **Comfortable and quiet operator's environment**

The operator inside deserves a comfortable, reliable and safe machine to work with. A good environment helps to spare operator, equipment and nature for years to come. The Volvo L150E is a super competitive wheel loader that puts the operator right in the middle, literally speaking. Tedious vibrations and noise have been heavily reduced. If the operator feels comfortable and secure, it's easier to stay attentive.

## **More than 95% recyclable**

The L150E is almost completely recyclable. We see it as a natural step in our commitment. Components such as the engine, transmission and hydraulics are re-engineered and re-used in our Parts Exchange program. The equipment has to be as trustworthy, service-friendly, productive and as cost-effective as possible. Choose this wheel loader for maximum productivity and minimal impact on operator, machinery and environment. Feel free to feel secure in a Volvo L150E.

## **Quality**

- The air is vented from all major components with easy to replace breather filters, used to prevent dirty air from entering the transmission, axles, fuel tank, and hydraulic tank.
- All electrical wires are routed through sturdy conduits, protected from water, dust, and abrasion with rubberized connectors and terminal caps.
- The L150E is designed from the beginning for easy service and maintenance. Easy access to all components lays the foundation for shorter service and maintenance time and longer life.

## **Safety**

- A dual-circuit service brake system that fulfills all requirements according to ISO 3450, electronic brake test in Contronic and easy to check brake wear indicators are all ways to ensure safe and effective braking.
- Volvo Care Cab is tested and approved according to ROPS ISO 3471 and FOPS ISO 3449 standards.
- Optimized panoramic visibility gives effective control over the entire work area.
- The L150E has steps and platforms that are equipped with anti-slip surfaces and well positioned hand rails.

## **Environment**

- The low rpm, high performance D12C engine meets all current emission requirements according to Tier 2/Stage 2 legislation in the US and Europe.
- The L150E is manufactured in environmentally certified factories according to ISO 14001.
- The L150E is more than 95% recyclable according to material weight.
- Low external and internal sound levels.





# VOLVO L150E IN DETAIL

## Engine

9,4 liter, 6-cylinder straight turbocharged diesel engine with 4 valves per cylinder, overhead camshaft and electronically controlled unit injectors. The engine has wet replaceable cylinder liners and replaceable valve guides and valve seats. The throttle application is transmitted electrically from the throttle pedal or the optional hand throttle. Air cleaning: three-stage. Cooling system: Air-to-air intercooler and hydrostatic, electronically controlled fan.

<b>Engine</b>	Volvo D9A LB E2
<b>Max power at</b>	26,7 r/s (1600 r/min)
<b>SAE J1995 gross</b>	211 kW (287 hp)
<b>ISO 9249, SAE J1349</b>	210 kW (284 hp)
<b>Max torque at</b>	23,3 r/s (1400 r/min)
<b>SAE J1995 gross</b>	1440 Nm
<b>ISO 9249, SAE J1349</b>	1430 Nm
<b>Economic working range</b>	1100-1600 r/min
<b>Displacement</b>	9,4 l

## Electrical system

Central warning system: Central warning light for the following functions, (buzzer with gear engaged): Engine oil pressure, charge air temperature, transmission oil pressure, brake pressure, parking brake applied, hydraulic oil level, steering pressure, low coolant level, coolant temperature, transmission oil temperature, hydraulic oil temperature, overspeeding in engaged gear, brake charging, axle oil temperature.

<b>Voltage</b>	24 V
<b>Batteries</b>	2x12 V
<b>Battery capacity</b>	2x140 Ah
<b>Cold cranking capacity, approx</b>	1050 A
<b>Reserve capacity, approx</b>	350 min
<b>Alternator rating</b>	1540 W/55 A
<b>Starter motor output</b>	5,5 kW (7,5 hp)

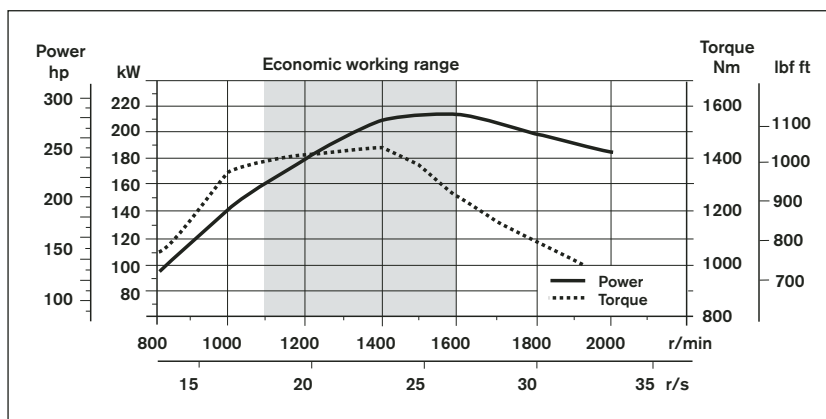

## Drivetrain

Torque converter: single-stage. Transmission: Volvo countershaft transmission with single lever control. Fast and smooth shifting of gears between forward and reverse with Pulse Width Modulation (PWM) valve. Gear shifting system: Volvo Automatic Power Shift (APS) with fully automatic shifting 1-4 and mode selector with 4 different gear shifting programs, including AUTO. Axles: Volvo fully floating axle shafts with planetary hub reductions and cast steel axle housings. Fixed front axle and oscillating rear axle. 100% differential lock on the front axle.

<b>Transmission</b>	Volvo HTE 210
<b>Torque multiplication</b>	2,4:1
<b>Maximum speed, forward/reverse</b>	
1	6,8 km/h
2	12,8 km/h
3	26,3 km/h
4	39,4 km/h
<b>Measured with tires</b>	26.5 R25 L3
<b>Front axle/rear axle</b>	Volvo/AWB 40/40
<b>Rear axle oscillation</b>	±15°
<b>Ground clearance at 15° osc.</b>	610 mm

## Brake system

Service brake: Volvo dual-circuit system with nitrogen charged accumulators. Outboard mounted hydraulically operated, fully sealed oil circulation cooled wet disc brakes. The operator can select automatic declutch of the transmission when braking through Contronic. Parking brake: Fully sealed, wet multi-disc brake built into the transmission. Applied by spring force and electro-hydraulically released with a switch on the instrument panel. Secondary brake: Dual brake circuits with rechargeable accumulators. Either one circuit or the parking brake fulfills all safety requirements. Standard: The brake system complies with the requirements of ISO 3450.

<b>Number of brake discs per wheel front/rear</b>	1/1
<b>Accumulators</b>	2x1,0 l and 1x0,5 l
<b>Accumulators for parking brake</b>	1x0,5 l

### Steering system

Steering system: Load-sensing hydrostatic articulated steering. System supply: The steering system has priority feed from a load-sensing axial piston pump with variable displacement. Steering cylinders: Two double-acting cylinders.

<b>Steering cylinders</b>	2
<b>Cylinder bore</b>	90 mm
<b>Piston rod diameter</b>	50 mm
<b>Stroke</b>	423 mm
<b>Working pressure</b>	21 MPa
<b>Maximum flow</b>	190 l/min
<b>Maximum articulation</b>	±37°

### Cab

Instrumentation: All important information is centrally located in the operator's field of view on the Contronic monitoring system's display unit. Heater and defroster: Heater coil with filtered fresh air and fan with four speeds. Defroster vents for all window areas. Operator seat: Ergonomic seat with adjustable suspension and retractable seatbelt. The seat is mounted on a bracket, which is mounted on the rear cab wall. The forces from the retractable seat belt are absorbed by the seat rail. Standard: The cab structure is tested and approved according to ROPS (ISO 3471) and FOPS (ISO 3449). The cab meets all requirements according to ISO 6055 (Operator Overhead Protection - Industrial Trucks) and SAE J386 (Operator Restraint System).

<b>Emergency exits</b>	1
<b>Sound level in cab according to ISO 6396</b>	LpA 69 dB (A)
<b>External sound level according to ISO 6395 (Directive 2000/14/EC)</b>	LwA 107 dB (A)
<b>Ventilation</b>	9 m <sup>3</sup> /min
<b>Heating capacity</b>	11 kW
<b>Air conditioning (optional)</b>	8 kW

### Hydraulic system

System supply: Two load-sensing axial piston pumps with variable displacement. The steering system always has priority. Valves: Double-acting 2-spool valve. The main valve is controlled by a 2-spool pilot valve. Lift function: The valve has four positions including raise, hold, lower and float. Inductive/magnetic automatic boom kickout can be switched on and off and is adjustable to any position between maximum reach and full lifting height. Tilt function: The valve has three functions including rollback, hold and dump. Inductive/magnetic automatic tilt can be adjusted to the desired bucket angle. Cylinders: Double-acting cylinders for all functions. Filter: Full flow filtration through 20 micron (absolute) filter cartridge.

<b>Working pressure maximum, pump 1</b>	25,0 MPa
<b>Flow at and engine speed</b>	180 l/min 10 MPa 32 r/s (1900 r/min)
<b>Working pressure, pump 2</b>	26,0 MPa
<b>Flow at and engine speed</b>	180 l/min 10 MPa 32 r/s (1900 r/min)
<b>Pilot system Working pressure</b>	3,5 MPa
<b>Cycle times</b>	
<b>Raise*</b>	5,9 s
<b>Tilt*</b>	2,0 s
<b>Lower, empty</b>	3,7 s
<b>Total cycle time</b>	11,6 s

\* with load as per ISO 14397 and SAE J818

### Lift arm system

Torque Parallel linkage (TP linkage) with high breakout torque and parallel action throughout the entire lifting range.

<b>Lift cylinders</b>	2
<b>Cylinder bore</b>	160 mm
<b>Piston rod diameter</b>	90 mm
<b>Stroke</b>	784 mm
<b>Tilt cylinder</b>	1
<b>Cylinder bore</b>	230 mm
<b>Piston rod diameter</b>	110 mm
<b>Stroke</b>	452 mm

### Service

Service accessibility: Large, easy-to-open service doors with gas struts. Swing-out radiator grille and cooling fan. Possibility to log and analyze data to facilitate troubleshooting.

<b>Refill capacities</b>	
<b>Fuel tank</b>	335 l
<b>Engine coolant</b>	44,5 l
<b>Hydraulic oil tank</b>	156 l
<b>Transmission oil</b>	45 l
<b>Engine oil</b>	39,5 l
<b>Axles front/rear</b>	45/55 l

# SPECIFICATIONS

## Tires: 26.5 R25 L3

	Standard boom	Long boom
B	7030 mm	7550 mm
C	3550 mm	—
D	450 mm	—
F	3580 mm	—
G	2130 mm	—
J	3960 mm	4530 mm
K	4350 mm	4920 mm
O	59 °	—
P <sub>max</sub>	49 °	—
R	44 °	47 °
R <sub>1</sub> *	48 °	—
S	66 °	61 °
T	54 mm	—
U	520 mm	—
X	2280 mm	—
Y	2950 mm	—
Z	3500 mm	3970 mm
a <sub>2</sub>	6780 mm	—
a <sub>3</sub>	3380 mm	—
a <sub>4</sub>	±37 °	—

\* Carry position SAE

Where applicable, specifications and dimensions are in accordance with ISO 7131, SAE J732, ISO 7546, SAE J742, ISO 14397, SAE J818.

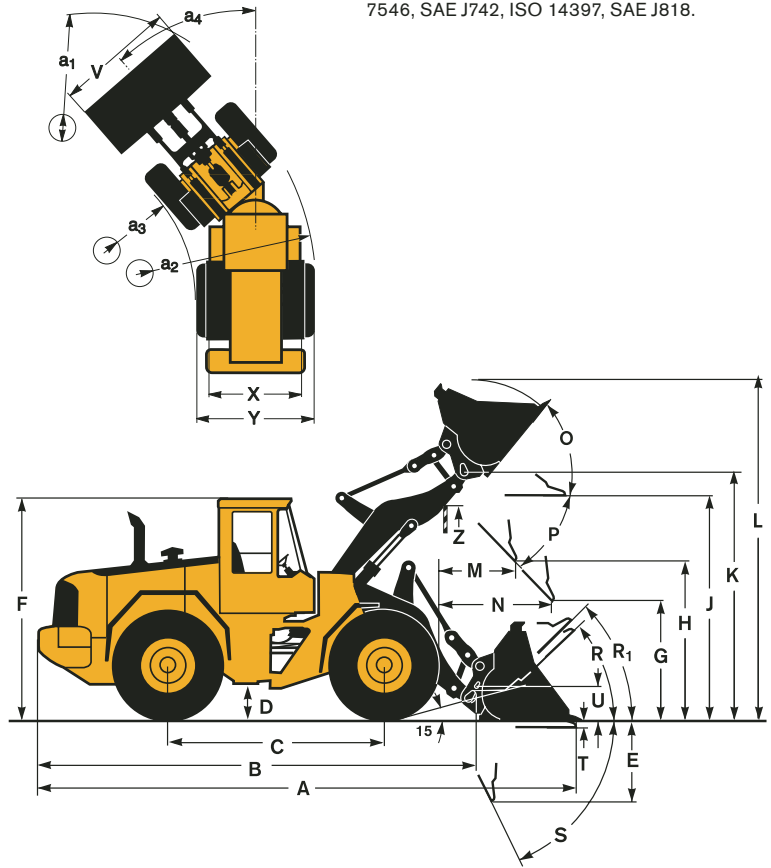

## Tires: 775/65 R29





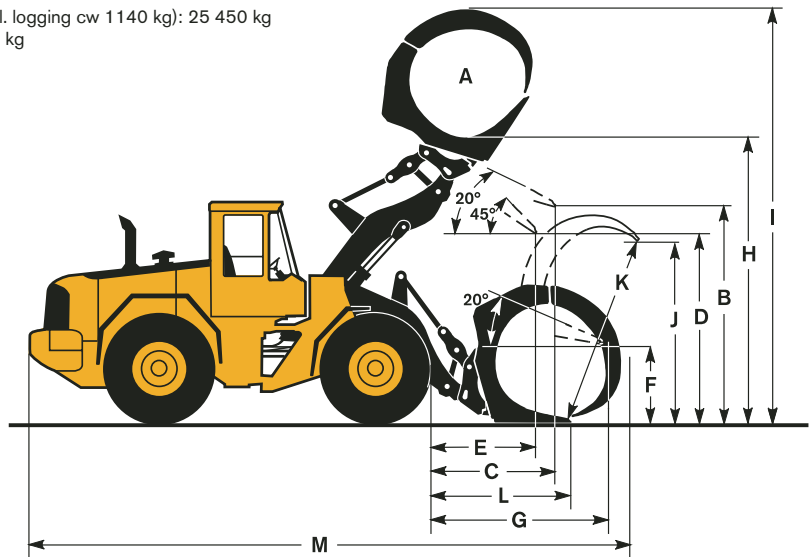



A	3,1 m <sup>2</sup>
B	3860 mm
C	1760 mm
D	3280 mm
E	1420 mm
F	1820 mm
G	2580 mm
H	4990 mm
I	7270 mm
J	3110 mm
K	3540 mm
L	1890 mm
M	9690 mm

Operating weight (incl. logging cw 1140 kg): 25 450 kg  
Operating load: 7700 kg



## Supplemental Operating Data

Tires 26.5 R25 L3	Standard Boom		Long Boom	
	26.5 R25 L5	775/65 R29	26.5 R25 L5	775/65 R29
Width over tires mm	+30	+110	+30	+110
Ground clearance mm	+30	+25	+30	+25
Tipping load, full turn kg	+770	+630	+650	+550
Operating weight kg	+1050	+920	+1050	+920

Tires 26.5 R25 L3	GENERAL PURPOSE					ROCK*		LIGHT MTRL	LONG BOOM	
	 Teeth	 Bolt-on edges	 Teeth	 Bolt-on edges	 Teeth	 Teeth & Segments	 Teeth & Segments	 Bolt-on edges		
Volume, heaped ISO/SAE	m <sup>3</sup>	3,8	4,0	4,3	4,0	4,2	3,5	3,8	6,8	—
Volume at 110% fill factor	m <sup>3</sup>	4,2	4,4	4,7	4,4	4,6	—	—	7,5	—
Static tipping load, straight	kg	17 820	17 440	17 380	16 730	16 740	17 170	16 900	16 530	-3500
at 35° turn	kg	15 890	15 510	15 450	14 850	14 840	15 220	14 990	14 650	-3210
at full turn	kg	15 680	15 290	15 230	14 640	14 630	14 990	14 770	14 440	-3170
Breakout force	kN	186,9	178,1	176,1	172,1	172,7	171,3	187,0	133,2	—
A	mm	8790	8610	8890	8680	8900	8910	8790	9140	+520
E	mm	1390	1250	1470	1290	1490	1500	1390	1700	+6
H**)	mm	2910	3000	2850	2990	2850	2830	2900	2630	+570
L	mm	5940	5850	6050	5940	6050	5950	5910	6100	+570
M**)	mm	1360	1210	1430	1270	1470	1440	1340	1540	-32
N**)	mm	1900	1790	1940	1830	1950	1940	1870	1930	+450
V	mm	3000	3200	3000	3200	3230	3230	3230	3200	—
a, clearance circle	mm	14 540	14 640	14 580	14 670	14 810	14 810	14 750	14 890	—
Operating weight	kg	23 020	23 160	23 340	23 510	23 670	23 690	23 630	23 660	+300





\*) With L5 tires

Note: This only applies to Volvo original attachments.

\*\*\*) Measured to the tip of the bucket teeth or bolt-on edge. Dump height to bucket edge. Measured at 45° dump angle. (Spade nose buckets at 42°.)

### Bucket Selection Chart

The chosen bucket is determined by the density of the material and the expected bucket fill factor. The actual bucket volume is often larger than the rated capacity, due to the features of the TP linkage, including an open bucket design, good rollback angles in all positions and good bucket filling performance. The example represents a standard boom configuration.  
**Example: Sand and gravel. Fill factor ~ 105%. Density 1,65 t/m<sup>3</sup>. Result: The 4,0 m<sup>3</sup> bucket carries 4,2 m<sup>3</sup>. For optimum stability always consult the bucket selection chart.**

Material	Bucket fill, %		Material density, t/m <sup>3</sup>	ISO/SAE bucket volume, m <sup>3</sup>	Actual volume, m <sup>3</sup>
Earth/Clay	~ 110		~ 1,65	3,8	~ 4,2
			~ 1,60	4,0	~ 4,4
			~ 1,50	4,2	~ 4,6
Sand/Gravel	~ 105		~ 1,70	3,8	~ 4,0
			~ 1,65	4,0	~ 4,2
			~ 1,60	4,2	~ 4,4
Aggregate	~ 100		~ 1,80	3,8	~ 3,8
			~ 1,75	4,0	~ 4,0
			~ 1,65	4,2	~ 4,2
Rock	≤100		~ 1,70	3,5	~ 3,5

The size of rock buckets is optimized for optimal penetration and filling capability rather than the density of the material.

Type of boom	Type of bucket	ISO/SAE Bucket volume	Material density (t/m <sup>3</sup> )						
			0,8	1,0	1,2	1,4	1,6	1,8	2,0
Standard boom	General purpose	3,8 m <sup>3</sup>					4,2	3,8	
		4,0 m <sup>3</sup>				4,4	4,0		
		4,2 m <sup>3</sup>			4,6	4,2			
	Rock	3,5 m <sup>3</sup>						3,5	3,3
		3,8 m <sup>3</sup>						3,8	3,5
	Light mtrl	6,8 m <sup>3</sup>	6,8						
Long boom	General purpose	3,7 m <sup>3</sup>			4,1	3,7			
	Rock	3,2 m <sup>3</sup>					3,2	3,0	
Bucket fill			110% 105% 100% 95%						

## STANDARD EQUIPMENT

### Engine

Three stage air cleaner with ejector and inner filter  
Indicator glass for coolant level  
Preheating of induction air  
Two fuel filters  
Oil trap

### Electrical system

24 V, prewired for optional accessories  
Alternator, 24 V/55 A  
Air filter for alternator  
Battery disconnect switch  
Fuel gauge  
Hour meter  
Electric horn  
Instrument panel with symbols  
Lighting:

- Twin halogen front headlights with high and low beams
- Parking lights
- Double brake and tail lights
- Turn signals with flashing hazard light function
- Halogen working lights (2 front and 2 rear)
- Instrument lighting

### Contronic monitoring system

ECU with log and analysis system  
Contronic display  
Fuel consumption  
Ambient temperature  
Engine shutdown to idle in case of malfunction indication:

- High engine coolant temperature
- Low engine oil pressure
- High transmission oil temperature

Start interlock when gear is engaged  
Brake test  
Test function for warning and indicator lights  
Warning and indicator lights:

- Charging
- Oil pressure engine
- Oil pressure, transmission
- Brake pressure
- Parking brake

- Hydraulic oil level
  - Axle oil temperature
  - Primary steering
  - Secondary steering
  - High beams
  - Turn signals
  - Rotating beacon
  - Preheating coil
  - Differential lock
  - Coolant temperature
  - Transmission oil temperature
  - Brake charging
- Level warnings:
- Engine oil level
  - Coolant level
  - Transmission oil level
  - Hydraulic oil level
  - Washer fluid level

### Drivetrain

Automatic Power Shift with operator-controlled declutch function for transmission cut-out when braking and mode selector with AUTO function  
Fully automatic shifting gears 1-4  
PWM-control between different gear positions  
Forward and reverse switch by lever console  
Differentials:

- front: 100% hydraulic diff lock
- rear: conventional

### Brake system

Wet oil circulation cooled disc brakes on all four wheels  
Dual brake circuits  
Dual service brake pedals  
Secondary brake system  
Parking brake, el-hydraulic  
Brake wear indicator

### Cab

ROPS (ISO 3471), FOPS (ISO 3449)  
Single key kit door/start  
Acoustic inner lining  
Ashtray  
Cigarette lighter

Lockable door  
Cab heating with filter, fresh-air inlet and defroster  
Floor mat  
Interior light  
Interior rear-view mirror  
2 exterior rear-view mirrors  
Openable window right-hand side  
Tinted safety glass  
Hip retractable seatbelt (SAE J386)  
Adjustable lever console  
Ergonomically designed operator's seat with adjustable suspension  
Storage compartment  
Sun visor  
Beverage holder  
Windshield washers front and rear  
Windshield wipers front and rear  
Interval function for front and rear windshield wipers  
Service platforms with anti-slip surfaces on front and rear fenders  
Speedometer

### Hydraulic system

Main valve, 2-spool  
Pilot valve, 2-spool  
Variable displacement axial piston pumps (3) for:

- working hydraulics
- steering system, pilot hydraulics and brakes
- fan motor

Boom lowering system  
Boom kickout, automatic, adjustable  
Bucket positioner, automatic with position indicator, adjustable  
Hydraulic oil cooler

### External equipment

Noise and vibration dampening suspension of cab, engine and transmission  
Lifting lugs  
Easy-to-open side panels  
Frame steering, joint lock  
Vandalism lock prepared for batteries and engine compartment  
Towing hitch

## OPTIONAL EQUIPMENT

(Standard on certain markets)

### Service and maintenance

Tool box, lockable  
Tool kit  
Automatic lubrication system  
Automatic lubrication system inclusive long boom  
Automatic lubrication system for attachment bracket, welded  
Refill pump for automatic lubrication system  
Wheel nut wrench kit  
Grease nipple guards  
Oil sampling valve

### Engine equipment

Engine block heater, 230 V  
Air pre-cleaner, oil bath type  
Air pre-cleaner, turbo type  
Air pre-cleaner, Sy-Klone type  
Hand throttle control  
Fuel fill strainer  
Coolant filter  
Fuel filter, extra large with water trap  
Fuel filter, with water trap and heating  
Radiator, corrosion protected  
Fan air intake protection  
Reversible cooling fan  
Reversible cooling fan in combination with axle oil cooler

### Electrical system

Alternator, 80 A  
Working light, attachments  
Working lights front, extra  
Working lights rear, extra  
Working lights front, on cab, dual  
Working lights front, high intensity  
License plate holder, lighting  
Assymetrical lights for left-hand traffic  
Reverse alarm  
Reverse light  
Shortened headlight support brackets  
Warning beacon, rotating, collapsible  
Battery disconnect switch, additional in cab  
Side marker lamps

### Cab

Installation kit for radio  
Radio with tape recorder  
Radio with CD-player

Sun blinds, front and rear windows  
Sun blinds, side windows  
Sliding window, right  
Sliding window, door  
Retractable hipbelt, longer and wider than standard  
Air conditioning with corrosion prot. condenser  
Air conditioning with corrosion prot. condenser and automatic temp. control (ATC)  
Ventilation air filter for work in asbestos environment  
Operator's seat with low backrest  
Operator's seat with low backrest and electrical heating  
Operator's seat with high backrest and electrical heating  
Operator's seat air suspended with high backrest and electrical heating  
Instructor's seat  
Armrest (left) for operator seat  
Adjustable steering wheel  
Steering wheel knob  
Noise reduction kit  
Rear view camera incl. monitor  
Rear view mirrors, el. heated  
Cab ladder, rubber suspended

### Drivetrain

Limited slip rear  
Speed limiter 20 km/h  
Speed limiter 30 km/h  
Wheel/axle seal guards

### Brake system

Oil cooler and filter for front and rear axle  
Oil cooler and filter for front and rear axle in comb. with reversible fan

### Hydraulic system

Single lever control  
Single lever control for 3rd hydraulic function  
3rd hydraulic function  
3rd hydraulic function for long boom  
3rd-4th hydraulic function  
Boom Suspension System  
Biodegradable hydraulic fluid  
Attachment bracket, welded  
Arctic kit, attachment locking hoses and 3rd hydraulic function  
Arctic kit, pilot hoses and brake accum. incl. hydraulic oil  
Separate attachment locking, standard boom  
Separate attachment locking, long boom  
Return-to-dig

### External equipment

Long boom  
Mudguards widener front/rear  
Mudguards, fixed front and swing out rear  
Deleted front mudguards and rear wideners  
Logging counterweight

### Protective equipment

Guards for front headlights  
Guards for taillights  
Guards for taillights, heavy-duty  
Guards for side and rear windows  
Guards for radiator grille  
Windshield guard  
Bellyguard front  
Bellyguard rear  
Bellyguard, oil pan  
Cover plate front frame, heavy-duty  
Cover plate, under cab  
Guards for steer cylinder  
Guards for boom cylinder hose and tube  
Corrosion protection, painting of machine  
Corrosion protection, painting of attachment bracket  
Bucket teeth protection

### Other equipment

Comfort Drive Control, CDC  
Secondary steering  
Sign, slow moving vehicle  
Sound decal, EU  
CE-marking

### Tires

775/65 R29  
26.5 R25

### Attachments

Buckets:

- Straight with/without teeth
- Spade nose with/without teeth
- High tipping
- Light materials

Bolt-on and weld-on bucket teeth  
Cutting edge in three sections, bolt-on  
Fork equipment  
Material handling arm  
Log grapples

### Boom Suspension System (BSS)\*

BSS utilizes gas/oil accumulators connected to the lift cylinders to absorb shocks and smooth out rough roads for faster cycle times, less spillage and increased operator comfort.



### Automatic Lubrication System\*

Our factory fitted Automatic Lubrication System takes care of greasing while the machine is in operation. This means less downtime for scheduled maintenance and more time for productive work.



### Comfort Drive Control (CDC)\*

CDC significantly reduces repetitive and tiring steering wheel movements. The operator can shift and steer easily with the aid of controls integrated in the left armrest.



### 3rd and 4th hydraulic functions\*

Volvo wheel loaders can be equipped with third and fourth hydraulic functions, which are operated with additional control levers.

These functions are necessary when there's a need to operate a third and fourth hydraulic function at the same time, such as when using a timber grapple with hydraulic heel kick-out.

### Volvo genuine attachments

Volvo offers a wide range of attachments and wear parts, including the new Volvo Tooth System. Volvo genuine attachments are designed for all types of applications, from handling timber to breaking out hard and rocky materials, such as shot rock.

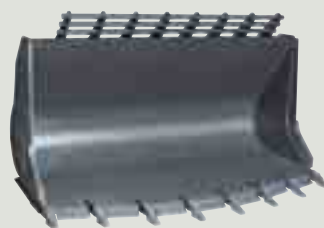

Spade nose rock bucket with teeth



Standard bucket with teeth



Standard bucket with edge savers

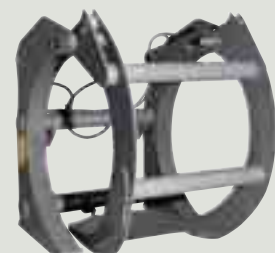

Timber grapple/Sorting grapple



Volvo Construction Equipment is different. It's designed, built and supported in a different way. That difference comes from an engineering heritage of over 170 years. A heritage of thinking first about the people who actually use the machines. About how to help them be safer, more comfortable, more productive. About the environment we all share. The result of that thinking is a growing range of machines and a global support network dedicated to helping you do more. People around the world are proud to use Volvo. And we're proud of what makes Volvo different – **More care. Built in.**



*All products are not available in all markets. Under our policy of continuous improvement, we reserve the right to change specifications and design without prior notice. The illustrations do not necessarily show the standard version of the machine.*

# **VOLVO**

**Construction Equipment**  
[www.volvo.com](http://www.volvo.com)

Ref. No. 21 A 100 1564  
Printed in Sweden 2005.04-2,0  
Volvo, Eskilstuna

English  
WLO