

# KOMATSU

## PW200-7

ENGINE POWER  
134 kW / 180 HP @ 2.000 rpm

OPERATING WEIGHT  
18.970 - 22.100 kg

BUCKET CAPACITY  
max. 1,58 m<sup>3</sup>

**PW**  
**200**

HYDRAULIC WHEELED EXCAVATOR



**PW200-7**

# WALK-AROUND

The PW200-7 is a rugged, productive, all-European machine. Designed and expressly built for European markets, it delivers productivity, reliability and operator comforts in a robust, environmentally-friendly package. Komatsu's exclusive, on-board, HydraMind system assists in all operations, providing enhanced machine performance that's always perfectly matched to the task.

## Advanced Attachment Control

The PW200-7 is equipped to handle a wide variety of attachments. The advanced attachment control system features:

- Operator selectable hydraulic flow control
- Adjustable presets for rapid attachment changeover
- Attachment piping options for breaker, clamshell or crusher

## Undercarriage

- Designed for high ground clearance
- Virtually zero axle rocking with out-board wet disc system
- Powerful drawbar pull
- Automatic 3-speed travel
- 35 km/h maximum travel speed
- Optional undercarriage width: 2,75 m



## Komatsu Tracking System

Track and monitor your machine anytime, anywhere for total peace of mind.

## High productivity

- High lifting capacity and good stability
- High drawbar pull
- Large bore bucket cylinders can be installed to the 1,8 m and 2,4 m arms to greatly increase digging forces and productivity in tough conditions.

## Excellent reliability and durability

- Reliable major components designed and built by Komatsu
- Exceptionally reliable electronic devices



## SpaceCab™

- Sealed and pressurised cab with standard climate control
- Low-noise design
- Low-vibration design with viscous cabin damper mounting
- Cab moved forward for better visibility
- Ergonomic control levers
- Seat specially designed for wheeled machines, with exceptional extra comfort

## In harmony with the environment

- The economy mode reduces fuel consumption
- Low operating noise
- Designed for easy end-of-life recycling

**ENGINE POWER**  
134 kW / 180 HP

**OPERATING WEIGHT**  
18.970 - 22.100 kg

**BUCKET CAPACITY**  
max. 1,58 m<sup>3</sup>



The Komatsu SAA6D107E-1 engine meets EU Stage IIIA and EPA Tier III emission regulations.





# EMMS

## EMMS (Equipment Management and Monitoring System)

The EMMS is a highly sophisticated system, controlling and monitoring all the excavator functions. The user interface is highly intuitive and provides the operator with easy access to a huge range of functions and operating information.

### Four working modes

The PW200-7 is equipped with three working modes: (P, E, B), plus a lifting mode (L). Each mode is designed to match the engine speed, pump speed, and system pressure with the current operating requirement. This provides the flexibility to match equipment performance to the job at hand.

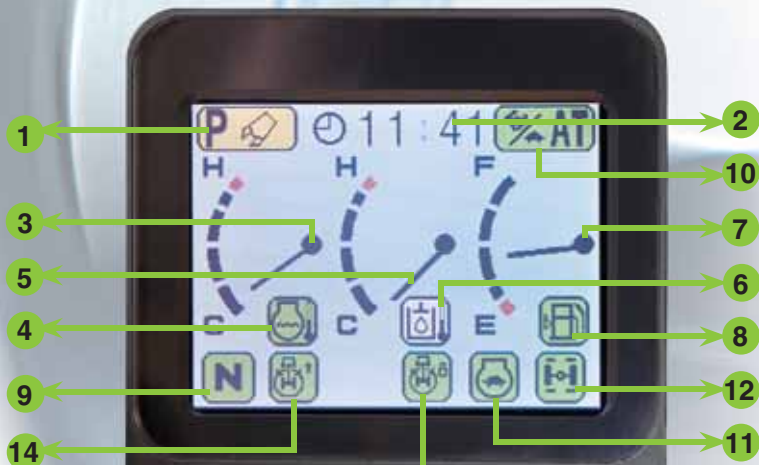

### On-screen symbols

- 1 Working mode
- 2 Service meter and clock
- 3 Engine water gauge
- 4 Engine water temperature warning
- 5 Hydraulic oil gauge
- 6 Hydraulic oil temperature warning
- 7 Fuel gauge
- 8 Fuel low level warning
- 9 Travel direction
- 10 Travel mode
- 11 Auto deceleration
- 12 Suspension lock
- 13 Swing lock
- 14 Swing position

### Push-button control switches

- 1 Working mode select
- 2 Creep speed
- 3 High/low speed select
- 4 Control lever lock
- 5 Menu select key
- 6 Service menu
- 7 Engine auto deceleration
- 8 Buzzer cancel
- 9 Brightness adjust
- 10 Suspension auto lock
- 11 Suspension lock
- 12 Accept key
- 13 Scroll down
- 14 Scroll up
- 15 Undo switch
- 16 Rear left outrigger/blade
- 17 Front left outrigger/blade
- 18 Front right outrigger
- 19 Rear right outrigger

## Power mode

For maximum power and fast cycle times. Normally used for heavy operations such as hard digging and loading. This mode allows access to the 'PowerMax' function to temporarily increase the digging force by 7% for added power in tough situations.

## Economy mode

The environmentally-friendly mode. For running more quietly during operations at night and/or in urban areas. Fuel consumption and exhaust emissions are reduced.

## Breaker mode

Delivers optimal hydraulic pressure, flow and engine RPMs for powerful breaker operations.

## Lifting mode

Increases the lifting capacity 7% by raising the hydraulic pressure. This mode supports safe lifting operations.

Working mode	Application	Advantage
P	Power mode	<ul style="list-style-type: none"> <li>• Maximum production/power</li> <li>• Fast cycle times</li> </ul>
E	Economy mode	<ul style="list-style-type: none"> <li>• Excellent fuel economy</li> </ul>
B	Breaker mode	<ul style="list-style-type: none"> <li>• Optimum engine RPMs and hydraulic flow</li> </ul>
L	Lifting mode	<ul style="list-style-type: none"> <li>• Hydraulic pressure has been increased by 7%</li> </ul>



Hydraulic flow general adjustment screen in B (breaker) mode



Fine tune hydraulic flow adjustment screen in B (breaker) mode



Fine tune hydraulic flow adjustment screen in P (power) or E (economy) mode



Password screen

## Easy to see and easy to use

Superb recognition colour LCD screens for each mode. Letters and numbers are combined with colour images for exceptionally clear and easy-to-read information. The high-resolution screen is easy to read in bright sunlight and in all lighting conditions.

## Automatic three-speed travel

The travel speed is automatically shifted from high to low speed, according to the ground conditions.

	High	Low	Auto	Creep
Travel speed	35 km/h	9 km/h	0 - 35 km/h	1,5 km/h

## Fingertip hydraulic pump oil flow adjustment

From the LCD monitor, you can automatically select the optimal hydraulic pump oil flow for breaking, crushing, and other operations in the B, P or E modes. Also, when simultaneously operating with attachments and work equipment, the flow to the attachment is reduced automatically, thus delivering a smooth movement of the work equipment.

## Password protection

Prevents unauthorised machine use or transport. The engine cannot be started without your four-digit use or password.

For total security, the battery is connected directly to the starter motor. Both the starter and the engine need the password.

The password can be activated and deactivated upon request.

# WORKING ENVIRONMENT

**PW200-7's cab interior is spacious and provides a comfortable working environment...**

## SpaceCab™

### Comfortable cab

The new PW200-7 inner cab volume is 14% greater than the Dash 6 models, offering an exceptionally comfortable operating environment. The large cab enables the seat, with headrest, to be reclined to horizontal.

### Pressurised cab

The standard-equipped climate control, air filter and a higher internal air pressure resist dust entry into the cab.

### Low-noise design

Noise levels are substantially reduced; engine noise as well as swing and hydraulics operations noise.

### Cab damper mounting for low vibration levels

PW200-7 uses a new and improved viscous damping cab mount system that incorporates a longer stroke plus an added spring. The new cab damper mounting, combined with strengthened left and right-side decks, aids the reduction of vibrations to the operator's seat.

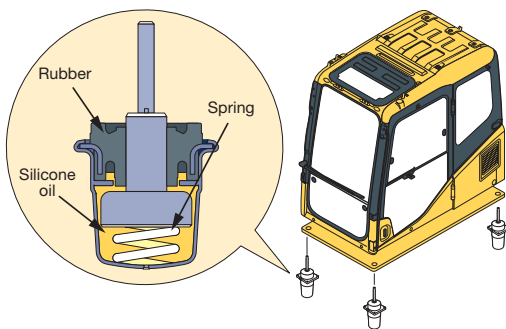

Outer air filter

Easy removal/installation of the air conditioner filter element, without tools facilitates easier cleaning.



Large sun roof with integrated sun shade



12-Volt power supply and (optional) radio cassette



Climate control



Tiltable steering wheel with several functions; wiper control, indicator, horn, and head lights



## Safety features

### Multi-position controls

The multi-position, proportional pressure control levers allow the operator to work in comfort whilst maintaining precise control. A double-slide mechanism allows the seat and controllers to move together, or independently, allowing the operator to position the controllers for maximum productivity and comfort.



Hot and cool box



Joysticks with proportional control button for attachments



Seat sliding range: 340 mm



Defroster/demister

### Improved, wide visibility

The right side window pillar has been removed and the rear pillar reshaped to provide greater visibility. Blind spots have been decreased by 34%.

### Pump/engine room partition

This prevents hydraulic oil from spraying onto the engine to reduce the risk of fire.

### Thermal and fan guards

Are placed around high-temperature parts of the engine.

### Steps with non-skid surface and large handrail

Steps with non-slip surfacing ensure safer maintenance.

Thermal guard



Non-slip sheet



Large handrail for safe access



# FLEXIBILITY

## ARMS

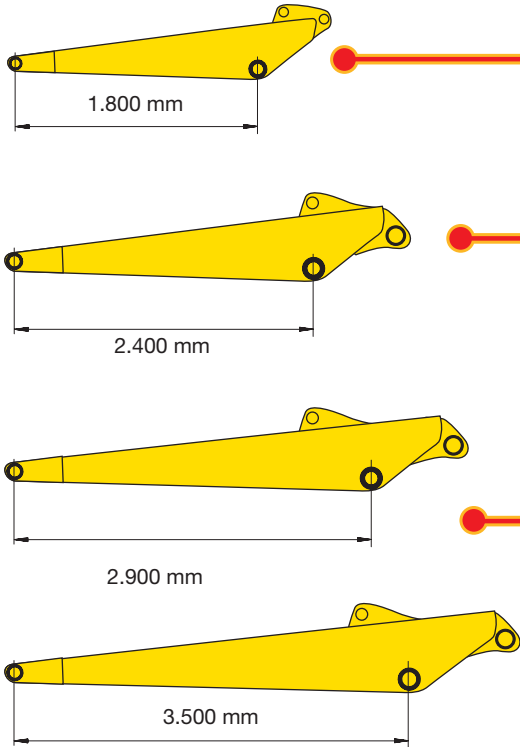

## BOOMS

Mono boom

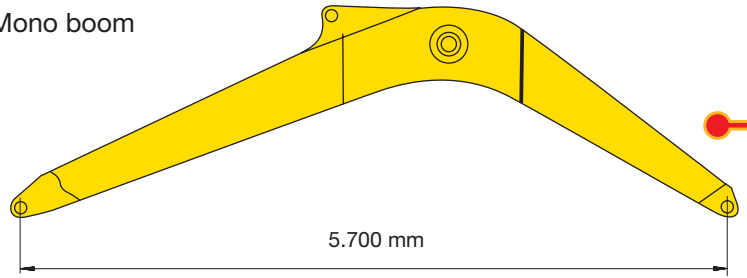

Two-piece boom

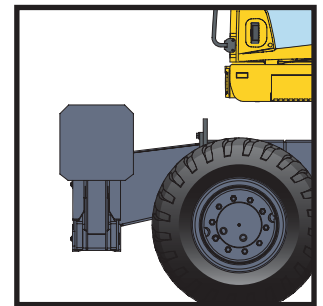
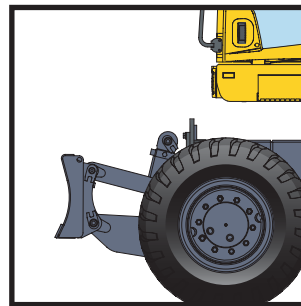
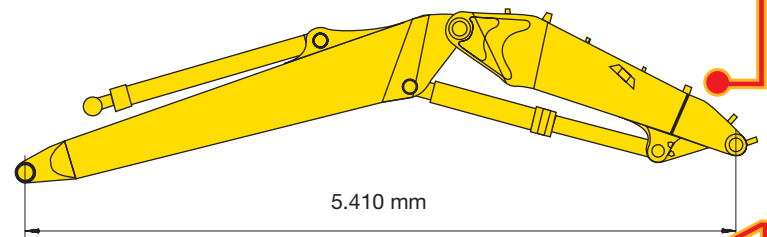

### Additional hydraulic circuits

A 2-way additional hydraulic circuit, electrically controlled from the wrist control levers, is fitted as standard.



### Outriggers

Independently controlled outriggers are optionally available on both, the front and rear of the machine. The cylinder protections are standard on the outriggers.



The PW200-7 can be specified with an enormous range of work equipment and undercarriage attachments to meet the needs of almost any application.

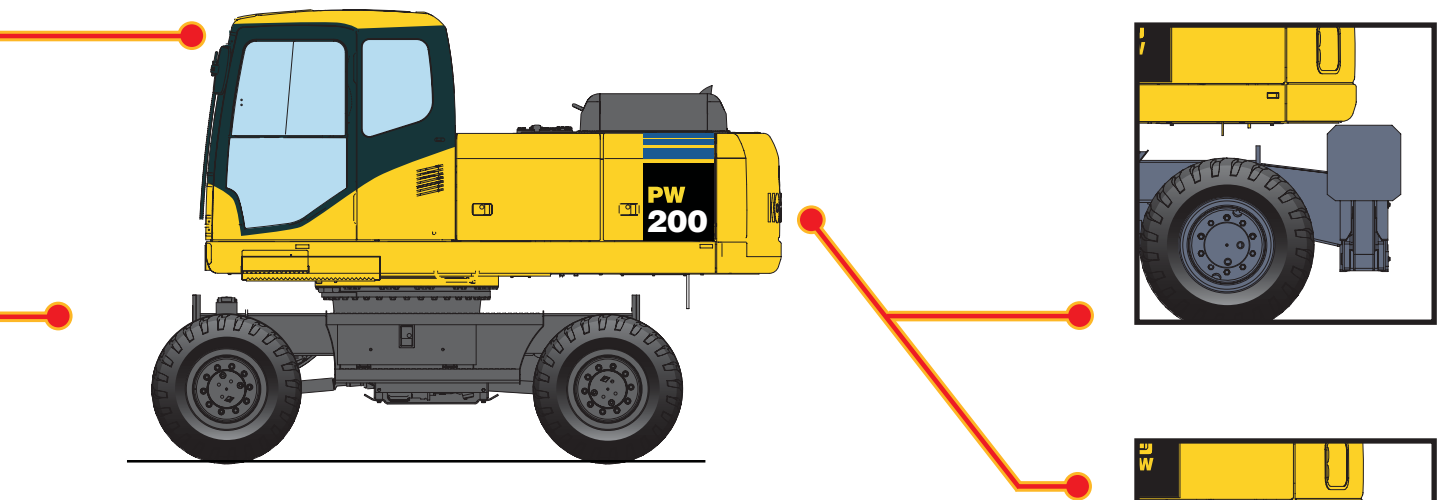

### Attachments commonality & functionality

The stabilizer and dozer blade are interchangeable, and therefore can be attached on the front or rear of the chassis. The stabilizer and dozer blade are controllable from the monitor panel. The monitor panel has four buttons that allow individual attachment operation as well as collective operation.



#### Toolbox

Tough, secure toolbox, integrated in the mudguards. Optionally fitted on both sides of the undercarriage.



#### Dozer blade

A parallel blade is available with standard cylinders protector for both the front and rear of the machine. Dimensions:  
with 2,55 m undercarriage: 2.550 mm × 520 mm  
with 2,75 m undercarriage: 2.750 mm × 520 mm

# EASY OPERATION

As well as operating the standard work equipment movements, the RH wrist control lever is also used to operate the undercarriage. When used in conjunction with the selection switch on the control panel, full independent control of outriggers and dozer blade is immediately available. This feature, together with the automatic axle lock, enables the machine to be moved, stabilized and operated extremely quickly.

## Travel control

A rock button is installed on the right hand lever, it controls the travel operation into forward, neutral and rear.



## Clamshell control

Anti-clock wise clamshell rotation.



## Undercarriage attachment control

After a single touch, the lever can be used to precisely operate the selected undercarriage attachment. After operating the undercarriage attachments, a single touch reverts the lever into standard boom operation.

## Breaker control

Used for breaker operation when B mode is selected.



# PRODUCTIVITY FEATURES



## Safe and precise lifting

PW200-7's stability is one of the best in its class. The machine is equipped with boom safety valves and overload caution as standard. This combined with the control of HydraMind and the power of the lifting mode, gives incredible safe and precise lifting performance.

Example: The over-front lifting capacity (reach 6,0 m over front, height 1,5 m) is 8,2 tonnes (outriggers front + rear, mono boom with 2,4 m arm and bucket).

## Improved fuel consumption

With its newly developed Komatsu ECOT3 engine, the PW200-7 significantly reduces hourly fuel consumption through highly efficient techniques for matching the engine and hydraulic unit. The Komatsu SAA6D107E-1 engine meets EPA Tier III, and EU Stage IIIA emissions regulations and reduces NOx emissions.

## PowerMax function

PowerMax can be selected by depressing a joystick button for an instant burst of power to help break through tough digging situations. The PowerMax function is available in the P and E working mode.

**Bucket digging force\*:** 17.950 kg

**Arm crowd force\*:** 14.800 kg

\* Measured with PowerMax function, 1.800 mm arm and ISO rating



## Superb visibility

Excellent all-round visibility is provided by large panoramic windows. Front visibility is further improved by the use of the Komatsu patented wiper system. When not in use the wiper parks on the cab frame itself with no contact with the front window. As well as giving excellent visibility, this systems avoids the need to disconnect the wiper before lifting the front window. The standard new plexiglas roof with sun visor gives the operator a better view of overhead obstacles and machine operations. It also allows more natural light to illuminate the cab's interior.



# REVOLUTIONARY MACHINE MANAGEMENT



The Komatsu Tracking System, KOMTRAX™, provides a revolutionary new way to monitor your equipment, anytime, anywhere. It lets you pin-point the precise location of your machines and obtain real-time machine data. Using GPS location and communication satellite technology, it's designed to be future proof and will meet your demands today and tomorrow.

Komtrax will help you to answer the three most important questions you have about your machine:

- Is the machine making money
- Is the machine safe
- Is the machine in good health

For more details, please ask your distributor for a copy of the Komtrax brochure.



KOMTRAX™ server

Check machine location



Customer



Check service meter



Annual working hour record

Machine ID	Year	Working Hours	Idle Hours	Total Hours
001	2010	1500	1000	2500
002	2010	1200	800	2000
003	2010	1800	1200	3000

Caution and periodic maintenance

Machine ID	Item	Due Date	Status
001	Oil Change	2010-10-15	Completed
001	Filter Replacement	2010-11-01	Pending
002	Inspection	2010-09-01	Completed

Working record (fuel level, hours etc.)

Date	Working Hours	Fuel Level	Temperature	Pressure
2010-10-01	100	100	100	100
2010-10-02	120	110	110	110
2010-10-03	150	120	120	120

There are certain countries where KOMTRAX™ is not yet available, please contact your distributor when you want to activate the system. Komtrax will not operate if the satellite signal is blocked or obscured.

# MAINTENANCE FEATURES

## Easy maintenance

Komatsu designed the PW200-7 to have easy service access. By doing this, routine maintenance and servicing are less likely to be skipped. This can mean a reduction in costly downtime later on. Here are some of the many service features found on the PW200-7:

### Easy access to the engine oil filter and fuel drain valve

The engine oil filter and fuel drain valve are mounted remotely to improve accessibility.

### Side-by-side cooling

The oil cooler and radiator are installed side by side. As a result, it is very easy to clean the radiator, etc. In addition, the operator can remove and install the aftercooler, radiator and oil cooler in a short time.

### Water separator

This is standard equipment which removes any water that has become mixed with the fuel, preventing fuel system damage.



### Designed and built for strength

Using the latest computer aided design techniques and exhaustive testing, the boom and arm designs have been optimised for strength and durability.

The highly automated manufacturing process uses the very latest equipment and quality control techniques. Critical welding is carried out by robots to ensure an extremely high quality and consistent product.

Precision engineered pin and bush system. The key work equipment joints use a chrome plated pin and bronze bushing system to provide minimal play and extended durability.

# SPECIFICATIONS



## ENGINE

Model ..... Komatsu SAA6D107E-1  
 Type..... Common rail direct injection, water-cooled, emissionised, turbocharged, after-cooled diesel  
 Engine power  
 at rated engine speed ..... 2.000 rpm  
 ISO 14396 ..... 134 kW/180 HP  
 ISO 9249 (net engine power) ..... 125 kW/168 HP  
 No. of cylinders ..... 6  
 Bore x stroke..... 107 x 124 mm  
 Displacement..... 6,69 ltr  
 Batteries ..... 2 x 12 V/120 Ah  
 Alternator..... 24 V/60 A  
 Starter motor ..... 24 V/5,5 kW  
 Air filter type ..... Double element type with monitor panel dust indicator and auto dust evacuator  
 Cooling ..... Suction type cooling fan



## HYDRAULIC SYSTEM

Type.....HydrauMind. Closed-centre system with load sensing and pressure compensation valves  
 Additional circuits..... Depending on the specification up to 2 additional proportional control & 1 quick coupler circuits can be installed  
 Main pump .....2 variable displacement piston pumps supplying boom, arm, bucket, swing and travel circuits  
 Maximum pump flow..... 2 x 218,4 ltr/min  
 Relief valve settings  
 Implement ..... 380 bar  
 Travel ..... 380 bar  
 Swing ..... 355 bar  
 Pilot circuit ..... 37 bar



## BRAKE SYSTEM

Type..... Dual circuit hydraulic braking system supplied from a separate gear pump.  
 Service brakes..... Pedal actuated wet multi-disc brakes integrated into the axle hubs.  
 Parking brake ..... Electrically actuated wet multi-disc “spring actuation hydraulic release” brake integrated into the transmission.



## ENVIRONMENT

Engine emissions ..... Fully complies with EU Stage IIIA and EPA Tier III exhaust emission regulations  
 Noise levels  
 LwA external ..... 103 dB(A) (2000/14/EC Stage II)  
 LpA operator ear..... 72 dB(A) (ISO 6396 dynamic test)



## SWING SYSTEM

Type..... Axial piston motor driving through planetary double reduction gearbox  
 Swing lock..... Electrically actuated wet multi-disc brake integrated into swing motor.  
 Swing speed..... 0 - 12,4 rpm  
 Swing torque ..... 68 kNm



## TRANSMISSION

Type..... Fully automatic power shift transmission with permanent 4 wheel drive  
 Travel motors ..... One variable displacement axial piston motor  
 Maximum pressure..... 380 bar  
 Travel modes..... Automatic + 3 travel modes  
 Max. travel speeds  
 Hi / Lo / Creep ..... 35,0 / 9,0 / 1,5 km/h  
 A max. speed restriction of 20 km/h is available as an option.  
 Maximum drawbar pull..... 12.600 kg  
 Front axle load..... Lower than 12.000 kg  
 Rear axle load..... Lower than 12.000 kg  
 Axle oscillation ..... 11° Lockable in any position from the operator cab.



## COOLANT AND LUBRICANT CAPACITY (REFILLING)

Fuel tank..... 370 ltr  
 Radiator ..... 17,6 ltr  
 Engine oil ..... 25,4 ltr  
 Swing drive..... 6,6 ltr  
 Hydraulic tank ..... 166 ltr  
 Transmission ..... 2,9 ltr  
 Front differential (2,55 m wide undercarriage) ..... 11,5 ltr  
 Front differential (2,75 m wide undercarriage) ..... 13,5 ltr  
 Rear differential (2,55 m wide undercarriage) ..... 10 ltr  
 Rear differential (2,75 m wide undercarriage) ..... 12 ltr  
 Front axle hub ..... 2,5 ltr  
 Rear axle hub ..... 2,0 ltr  
 Swing pinion grease bath amount..... 33 ltr



## STEERING SYSTEM

Steering control ..... Hydraulic steering system supplied from a separate gear pump and controlled through LS orbitrol & priority valves.  
 Minimum turning radius  
 2,55 m wide undercarriage ..... 6.850 mm (to center of outer wheel)  
 2,75 m wide undercarriage ..... 7.050 mm (to center of outer wheel)





## OPERATING WEIGHT (APPR.)

Operating weight, including specified work equipment, 2.400 mm arm, operator, lubricant, coolant, full fuel tank and the standard equipment. Weights are without bucket.

UNDERCARRIAGE ATTACHMENT TYPE	MONO BOOM		TWO-PIECE BOOM	
	2,55 m undercarriage	2,75 m undercarriage	2,55 m undercarriage	2,75 m undercarriage
Undercarriage type				
Without stabilizer	18.970 kg	19.260 kg	19.650 kg	19.940 kg
Rear blade	19.850 kg	20.170 kg	20.530 kg	20.850 kg
Rear outrigger	19.980 kg	20.340 kg	20.660 kg	21.020 kg
2 outriggers + blade	20.860 kg	21.270 kg	21.540 kg	21.930 kg
4 outriggers	20.990 kg	21.420 kg	21.670 kg	22.100 kg



## BUCKET OPTIONS & DIGGING FORCES

Specifications and equipment may vary according to regional availability.

BUCKET AND ARM COMBINATIONS			ARM LENGTH							
Bucket			2,55 m undercarriage				2,75 m undercarriage			
Width	Capacity (SAE)	Weight	1,8 m	2,4 m	2,9 m	3,5 m	1,8 m	2,4 m	2,9 m	3,5 m
600 mm	0,48 m <sup>3</sup>	480 kg	○	○	○	○	○	○	○	○
700 mm	0,55 m <sup>3</sup>	530 kg	○	○	○	○	○	○	○	○
800 mm	0,63 m <sup>3</sup>	580 kg	○	○	○	○	○	○	○	○
900 mm	0,71 m <sup>3</sup>	610 kg	○	○	○	○	○	○	○	○
1.000 mm	0,78 m <sup>3</sup>	650 kg	○	○	○	□	○	○	○	○
1.100 mm	0,86 m <sup>3</sup>	700 kg	○	○	□	△	○	○	○	○
1.200 mm	0,96 m <sup>3</sup>	760 kg	○	○	□	△	○	○	○	□
1.300 mm	1,03 m <sup>3</sup>	810 kg	○	□	△	-	○	○	□	△
1.400 mm	1,11 m <sup>3</sup>	870 kg	□	△	△	-	○	□	□	△
1.500 mm	1,19 m <sup>3</sup>	930 kg	△	△	-	-	□	□	△	-
1.600 mm	1,49 m <sup>3</sup>	1.100 kg	-	-	-	-	□	-	-	-
1.700 mm	1,58 m <sup>3</sup>	1.150 kg	-	-	-	-	△	-	-	-

Please consult with your distributor for the correct selection of buckets and attachments to suit the application. The recommendations are given as a guide only, based on typical operating conditions.

- Material weight up to 1,8 t/m<sup>3</sup>
- Material weight up to 1,5 t/m<sup>3</sup>
- △ Material weight up to 1,2 t/m<sup>3</sup>
- Not usable

BUCKET AND ARM FORCE				
Arm length	1.800 mm	2.400 mm	2.900 mm	3.500 mm
Bucket digging force	16.620 kg*	16.620 kg*	14.170 kg	14.170 kg
Bucket digging force at PowerMax	17.950 kg*	17.950 kg*	15.190 kg	15.190 kg
Arm crowd force	13.800 kg	12.200 kg	10.300 kg	8.500 kg
Arm crowd force at PowerMax	14.800 kg	13.000 kg	11.000 kg	9.100 kg

\* With optional large bucket cylinder

# DIMENSIONS

## MONO BOOM

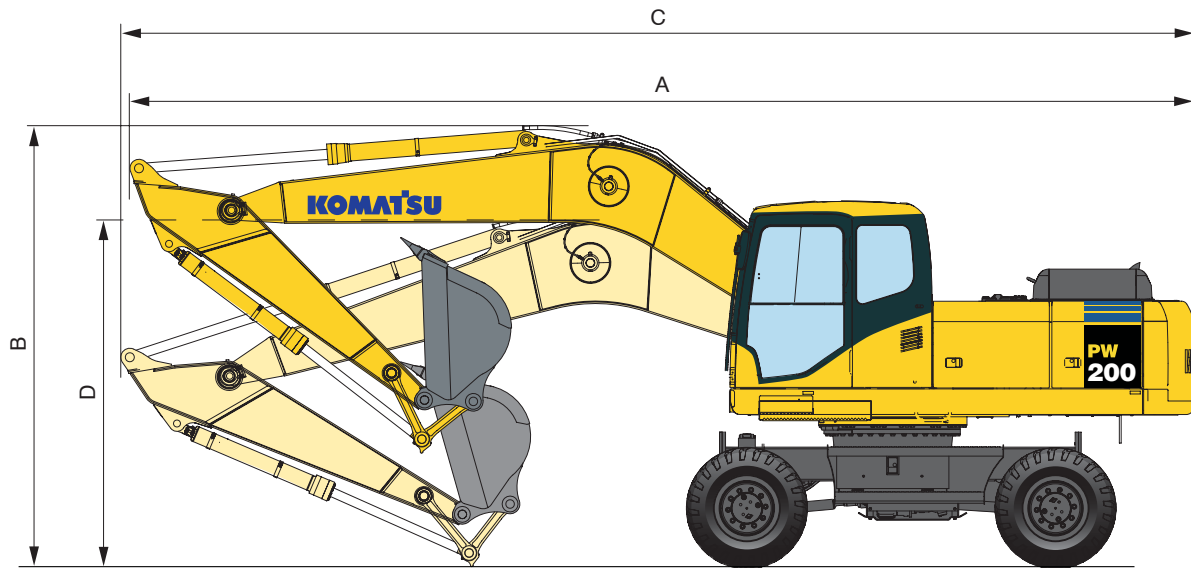

Arm length	Driving position		Transport position	
	A	B	C	D
1.800 mm	9.479 mm	3.906 mm	9.705 mm	3.266 mm
2.400 mm	9.435 mm	3.895 mm	9.659 mm	3.196 mm
2.900 mm	9.427 mm	3.912 mm	9.596 mm	3.018 mm
3.500 mm	9.467 mm	3.985 mm	9.639 mm	3.570 mm

## TWO-PIECE BOOM

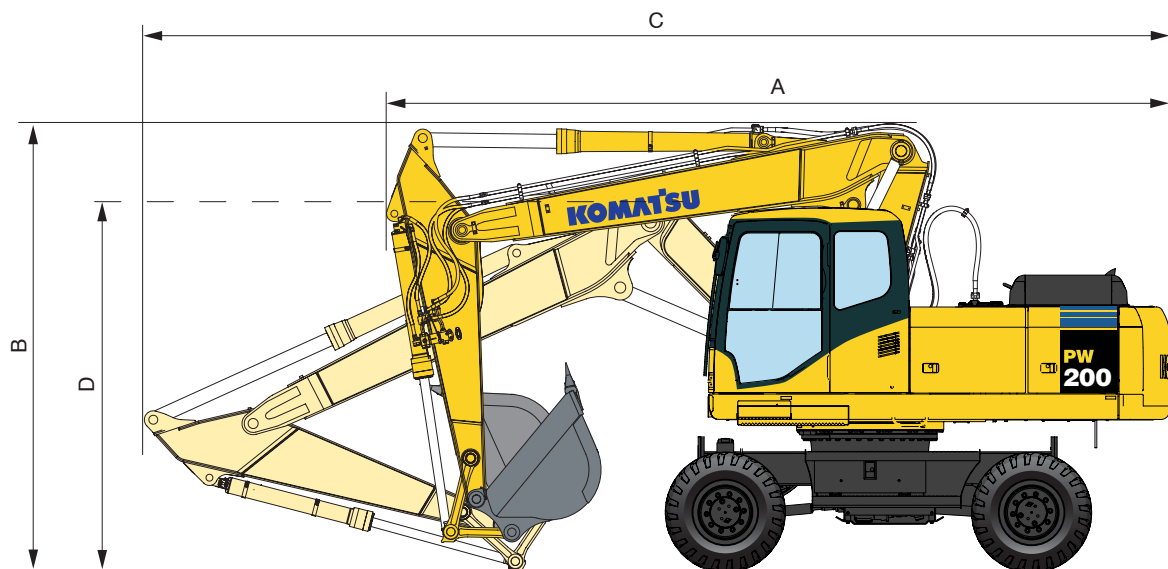

Arm length	Driving position		Transport position	
	A	B	C	D
1.800 mm	7.070 mm	3.980 mm	9.466 mm	3.040 mm
2.400 mm	7.078 mm	3.980 mm	9.470 mm	3.152 mm
2.900 mm	7.000 mm	3.997 mm	9.289 mm	3.095 mm
3.500 mm	7.218 mm	4.505 mm	9.225 mm	3.715 mm

# DIMENSIONS & UNDERCARRIAGE

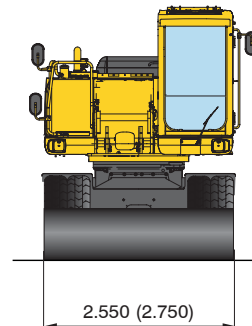
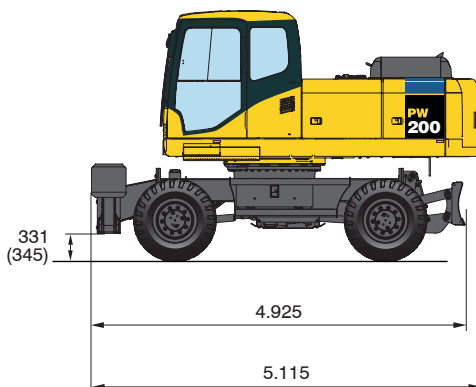
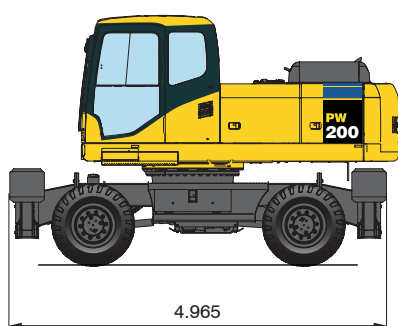
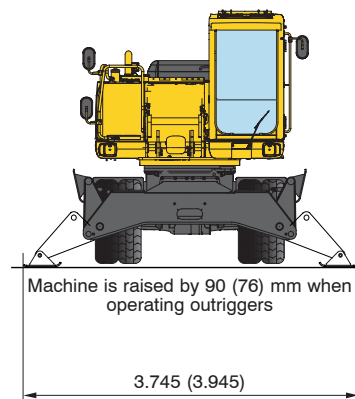
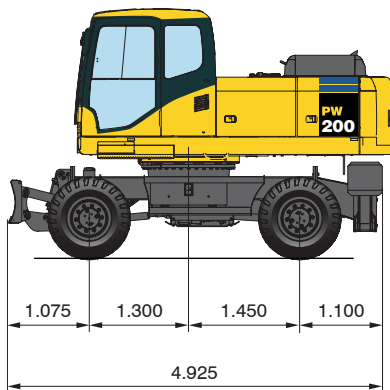
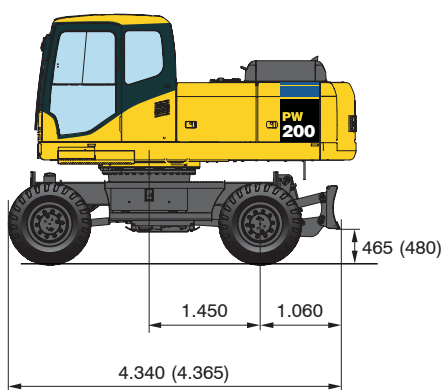
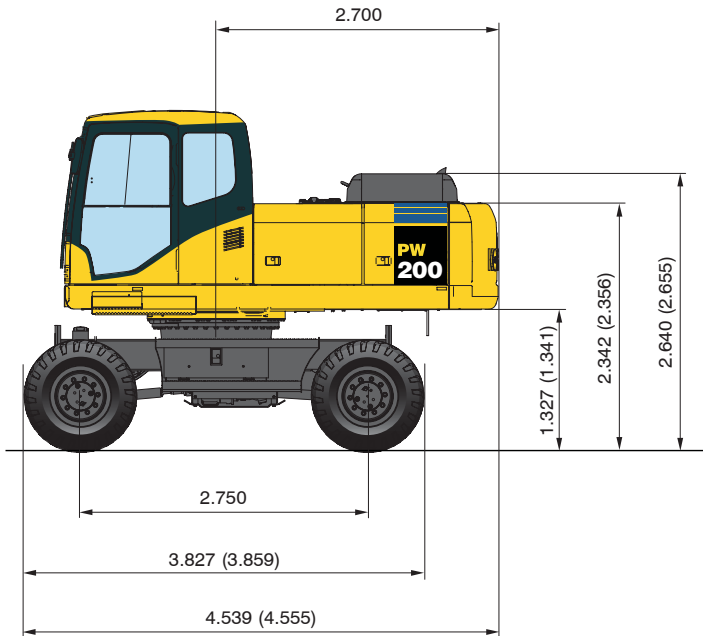
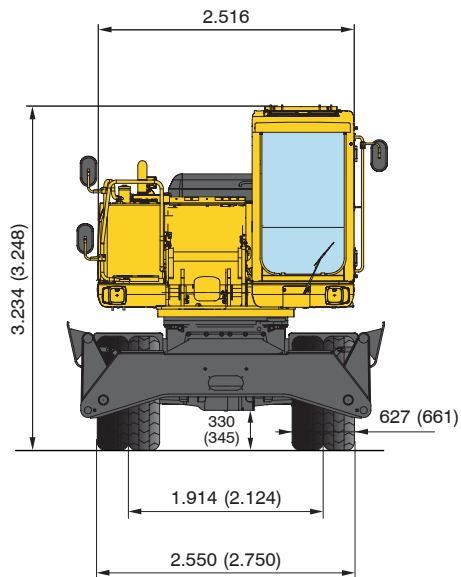

( ): Figures for 2,75 m undercarriage and 11.00-20 tyres



# WORKING RANGE

## MONO BOOM

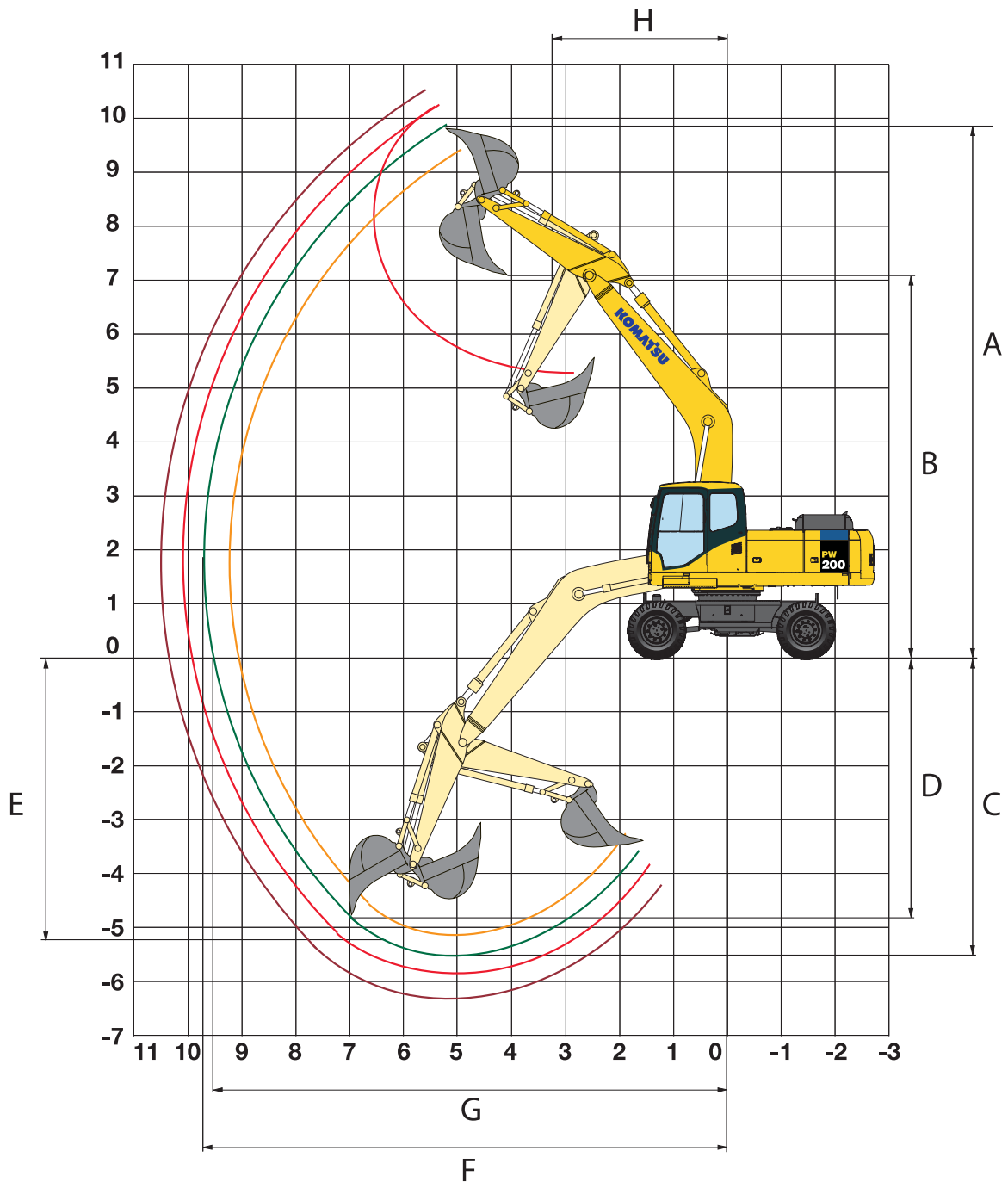

ARM LENGTH		1.800 mm	2.400 mm	2.900 mm	3.500 mm
A	Max. digging height	9.467 mm	9.883 mm	10.003 mm	10.438 mm
B	Max. dumping height	6.704 mm	7.057 mm	7.229 mm	7.612 mm
C	Max. digging depth	4.791 mm	5.402 mm	5.917 mm	6.500 mm
D	Max. vertical wall digging depth	4.141 mm	4.745 mm	5.227 mm	5.809 mm
E	Max. digging depth of cut for 2,44 m level	4.575 mm	5.225 mm	5.763 mm	6.366 mm
F	Max. digging reach	9.061 mm	9.651 mm	10.060 mm	10.642 mm
G	Max. digging reach at ground level	8.867 mm	9.438 mm	9.875 mm	10.478 mm
H	Min. swing radius	3.906 mm	3.201 mm	3.143 mm	3.148 mm

TWO-PIECE BOOM

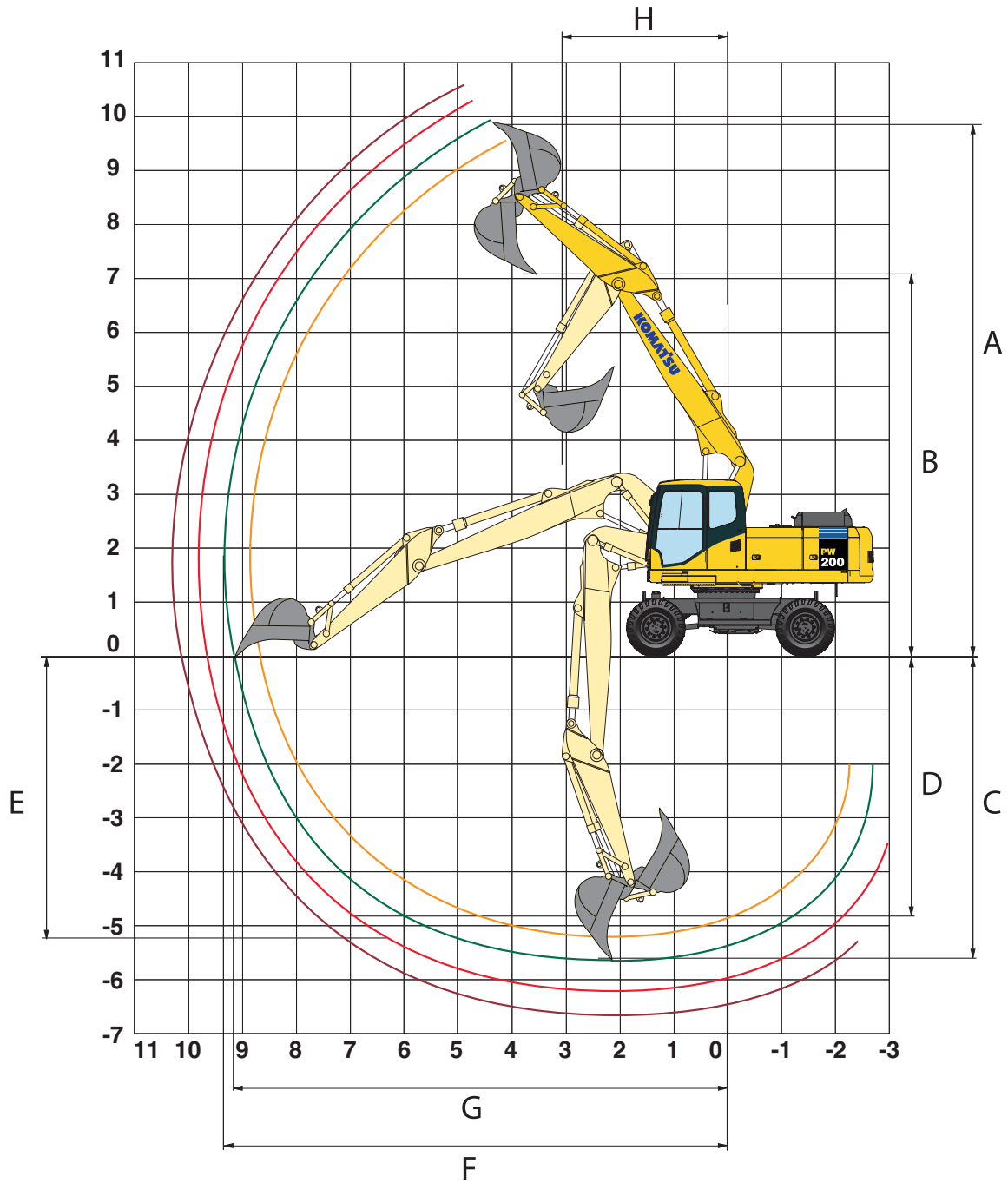



ARM LENGTH		1.800 mm	2.400 mm	2.900 mm	3.500 mm
A	Max. digging height	9.532 mm	9.842 mm	10.168 mm	10.434 mm
B	Max. dumping height	6.670 mm	6.982 mm	7.298 mm	7.574 mm
C	Max. digging depth	5.186 mm	5.785 mm	6.285 mm	6.860 mm
D	Max. vertical wall digging depth	4.104 mm	4.666 mm	5.208 mm	5.768 mm
E	Max. digging depth of cut for 2,44 m level	5.119 mm	5.713 mm	6.226 mm	6.793 mm
F	Max. digging reach	8.818 mm	9.348 mm	9.822 mm	10.338 mm
G	Max. digging reach at ground level	8.599 mm	9.144 mm	9.634 mm	10.156 mm
H	Min. swing radius	2.594 mm	3.121 mm	2.745 mm	2.866 mm



Arm length	A	9,0 m		7,5 m		6,0 m		4,5 m		3,0 m		1,5 m	

 Rear outrigger	1.800 mm	7,5 m	kg	*4.800	4.450										
		6,0 m	kg	*4.450	3.000										
		4,5 m	kg	*4.400	2.400										
		3,0 m	kg	*4.650	2.150										
		1,5 m	kg	4.950	2.000										
		0,0 m	kg	5.100	2.100										
	2.400 mm	-1,5 m	kg	*4.750	2.350										
		-3,0 m	kg	*3.600	3.000										
		7,5 m	kg	*4.250	3.650										
		6,0 m	kg	*4.000	2.600										
		4,5 m	kg	*4.050	2.150										
		3,0 m	kg	*4.200	1.900										
2.900 mm	1,5 m	kg	4.450	1.800											
	0,0 m	kg	4.550	1.850											
	-1,5 m	kg	*4.650	2.050											
	-3,0 m	kg	*3.950	2.500											
	7,5 m	kg	*2.650	*2.650											
	6,0 m	kg	*2.550	2.250											
3.500 mm	4,5 m	kg	*2.550	1.650											
	3,0 m	kg	*2.650	1.450											
	1,5 m	kg	*2.900	1.400											
	0,0 m	kg	*3.250	1.400											
	-1,5 m	kg	*3.900	1.500											
	-3,0 m	kg	*3.900	1.800											

 Outrigger + blade	1.800 mm	7,5 m	kg	*4.850	*4.850										
		6,0 m	kg	*4.500	4.000										
		4,5 m	kg	*4.500	3.250										
		3,0 m	kg	4.700	2.900										
		1,5 m	kg	4.550	2.800										
		0,0 m	kg	4.700	2.850										
	2.400 mm	-1,5 m	kg	*4.800	3.200										
		-3,0 m	kg	*3.700	*3.700										
		7,5 m	kg	*4.350	*4.350										
		6,0 m	kg	*4.100	3.500										
		4,5 m	kg	*4.100	2.900										
		3,0 m	kg	4.200	2.600										
2.900 mm	1,5 m	kg	4.100	2.500											
	0,0 m	kg	4.200	2.550											
	-1,5 m	kg	4.650	2.800											
	-3,0 m	kg	*4.000	3.450											
	7,5 m	kg	*2.700	*2.700											
	6,0 m	kg	*2.600	*2.600											
3.500 mm	4,5 m	kg	*2.600	2.300											
	3,0 m	kg	*2.700	2.050											
	1,5 m	kg	*2.950	2.000											
	0,0 m	kg	*3.300	2.000											
	-1,5 m	kg	3.650	2.150											
	-3,0 m	kg	*3.950	2.550											

 Outrigger front + rear	1.800 mm	7,5 m	kg	*4.800	*4.800										
		6,0 m	kg	*4.450	*4.450										
		4,5 m	kg	*4.400	4.000										
		3,0 m	kg	*4.650	3.600										
		1,5 m	kg	*5.100	3.500										
		0,0 m	kg	*5.350	3.600										
	2.400 mm	-1,5 m	kg	*4.750	4.050										
		-3,0 m	kg	*3.600	*3.600										
		7,5 m	kg	*4.350	*4.350										
		6,0 m	kg	*4.100	*4.100										
		4,5 m	kg	*4.100	3.600										
		3,0 m	kg	*4.300	3.250										
2.900 mm	1,5 m	kg	4.550	3.150											
	0,0 m	kg	4.700	3.200											
	-1,5 m	kg	*4.750	3.550											
	-3,0 m	kg	*4.000	*4.000											
	7,5 m	kg	*2.700	*2.700											
	6,0 m	kg	*2.600	*2.600											
3.500 mm	4,5 m	kg	*2.600	2.600											
	3,0 m	kg	*2.700	2.700											
	1,5 m	kg	*2.950	2.800											
	0,0 m	kg	*3.350	2.900											
	-1,5 m	kg	*4.050	3.150											
	-3,0 m	kg	*4.000	3.700											



# LIFTING CAPACITY

## TWO-PIECE BOOM

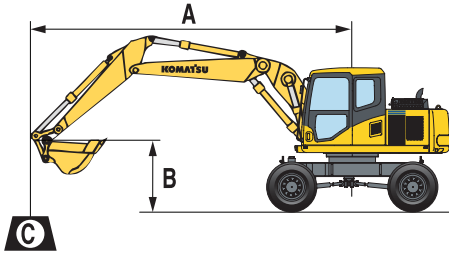

- A** – Reach from swing centre
- B** – Bucket hook height
- C** – Lifting capacities, including bucket (760 kg), bucket linkage (130 kg) and bucket cylinder (182 kg)

When removing bucket, linkage or cylinder, lifting capacities can be increased by their respective weights

\* Load is limited by hydraulic capacity rather than tipping.  
Ratings are based on SAE Standard No. J1097.  
Rated loads do not exceed 87% of hydraulic lift capacity or 75% of tipping load.

Undercarriage width: 2,55 m

– Rating over front

– Rating over side

– Rating at maximum reach

Arm length	A			9,0 m		7,5 m		6,0 m		4,5 m		3,0 m		1,5 m	

Without stabilizer	B	1,800 mm	7,5 m		6,0 m		4,5 m		3,0 m		1,5 m				
			kg	*kg	kg	*kg	kg	*kg	kg	*kg	kg	*kg			
		1,800 mm	7,5 m	kg	*5,050	3,900									
			6,0 m	kg	4,000	2,450			4,650	2,900			*6,400	5,000	
			4,5 m	kg	3,150	1,850			4,550	2,800	7,600	4,650	*11,000	9,000	
			3,0 m	kg	2,750	1,550			2,900	1,650	4,300	2,550	6,700	3,900	
			1,5 m	kg	2,650	1,450			2,800	1,550	4,050	2,350	6,300	3,550	
			0,0 m	kg	2,700	1,500			2,700	1,500	3,800	2,150	6,000	3,300	
			-1,5 m	kg	3,050	1,700					3,800	2,100	6,000	3,300	
			-3,0 m	kg									6,150	3,450	
			7,5 m	kg	*4,400	3,050									
			6,0 m	kg	3,450	2,050			4,850	3,050					
			4,5 m	kg	2,800	1,600			3,050	1,800	4,700	2,900	*6,850	4,900	
			3,0 m	kg	2,450	1,400			2,950	1,700	4,400	2,650	7,200	4,300	
1,5 m	kg	2,350	1,300			2,800	1,600	4,100	2,400	6,500	3,750				
0,0 m	kg	2,400	1,300			2,700	1,500	3,900	2,200	6,100	3,400				
-1,5 m	kg	2,650	1,450			2,700	1,450	3,750	2,100	6,000	3,300				
-3,0 m	kg	3,300	1,850			3,850	2,150	6,050	3,350	12,800	6,450				
7,5 m	kg	*2,800	2,500					*4,150	3,100						
6,0 m	kg	*2,600	1,750			3,100	1,850	4,750	3,000	*6,050	5,050				
4,5 m	kg	2,450	1,400			3,000	1,750	4,500	2,750	7,400	4,450				
3,0 m	kg	2,200	1,200			2,850	1,600	4,150	2,450	6,650	3,850				
1,5 m	kg	2,100	1,100			2,750	1,500	3,900	2,200	6,150	3,400				
0,0 m	kg	2,100	1,100			2,700	1,450	3,900	2,200	6,150	3,400				
-1,5 m	kg	2,300	1,200			2,600	1,400	3,750	2,050	5,950	3,250				
-3,0 m	kg	2,800	1,500			3,750	2,050	5,950	3,250	12,550	6,250				
7,5 m	kg	*2,700	2,050												
6,0 m	kg	*2,550	1,500			3,200	1,950	*4,100	3,200						
4,5 m	kg	2,150	1,200			3,150	1,900	*4,700	3,050						
3,0 m	kg	1,950	1,000	2,050	1,100	3,000	1,750	4,600	2,800	*7,000	4,650				
1,5 m	kg	1,850	900	1,950	1,000	2,850	1,600	4,250	2,500	6,750	3,900				
0,0 m	kg	1,850	900	1,900	950	2,700	1,450	3,900	2,200	6,250	3,500				
-1,5 m	kg	2,000	1,000			2,550	1,350	3,700	2,000	5,950	3,200				
-3,0 m	kg	2,350	1,250			2,550	1,350	3,650	1,950	5,850	3,150				

Rear blade	B	1,800 mm	7,5 m		6,0 m		4,5 m		3,0 m		1,5 m	
			kg	*kg	kg	*kg	kg	*kg	kg	*kg	kg	*kg
		1,800 mm	7,5 m	kg	*5,050	4,450					*6,400	5,750
			6,0 m	kg	*4,550	2,850			6,050	3,350	*6,550	5,750
			4,5 m	kg	*4,450	2,200			6,400	3,250	*7,750	5,400
			3,0 m	kg	*4,600	1,900			5,100	2,000	*7,150	3,050
			1,5 m	kg	4,750	1,800			5,000	1,900	7,350	2,800
			0,0 m	kg	4,900	1,800			4,900	1,850	7,100	2,550
			-1,5 m	kg	5,550	2,050					7,050	2,550
			-3,0 m	kg								
			7,5 m	kg	*4,400	3,500					*5,350	3,500
			6,0 m	kg	*4,100	2,450					5,350	3,500
			4,5 m	kg	4,050	1,950			5,300	2,150	*5,850	3,350
			3,0 m	kg	*4,200	1,650			5,200	2,050	*6,700	3,100
1,5 m	kg	4,250	1,550			5,050	1,950	7,450	2,850			
0,0 m	kg	4,350	1,600			4,900	1,850	7,150	2,650			
-1,5 m	kg	4,850	1,800			4,900	1,800	7,000	2,550			
-3,0 m	kg	*6,000	2,250			7,100	2,600	*7,100	2,600			
7,5 m	kg	*2,800	*2,800					*4,150	3,550			
6,0 m	kg	*2,600	2,100			*3,200	2,200	*4,800	3,600			
4,5 m	kg	*2,550	1,700			*4,950	2,200	*5,350	3,450			
3,0 m	kg	*2,650	1,450			5,250	2,050	*6,250	3,200			
1,5 m	kg	*2,900	1,350			5,050	1,950	*7,200	2,900			
0,0 m	kg	*3,250	1,400			4,900	1,800	7,200	2,650			
-1,5 m	kg	*3,950	1,500			4,800	1,750	7,000	2,500			
-3,0 m	kg	5,150	1,850					7,000	2,500			
7,5 m	kg	*2,750	2,400									
6,0 m	kg	*2,550	1,800			*3,950	2,300	*4,100	3,700			
4,5 m	kg	*2,550	1,450			*4,500	2,250	*4,700	3,550			
3,0 m	kg	*2,650	1,250	*3,350	1,350	*4,950	2,100	*5,650	3,250			
1,5 m	kg	*2,850	1,200	3,650	1,300	5,100	1,950	*6,750	2,950			
0,0 m	kg	*3,200	1,200	3,550	1,200	4,900	1,800	7,250	2,650			
-1,5 m	kg	3,750	1,300			4,750	1,700	7,000	2,450			
-3,0 m	kg	4,400	1,550			4,750	1,650	6,900	2,400			

# HYDRAULIC WHEELED EXCAVATOR

# PW200-7

Arm length	A	9,0 m		7,5 m		6,0 m		4,5 m		3,0 m		1,5 m	

Rear outrigger	B	7,5 m	6,0 m	4,5 m	3,0 m	1,5 m	1.800 mm		2.400 mm		2.900 mm		3.500 mm	
							kg	kg	kg	kg	kg	kg	kg	kg
7,5 m	kg	*5.050	*5.050											
6,0 m	kg	*4.550	3.300											
4,5 m	kg	*4.450	2.600											
3,0 m	kg	*4.600	2.250											
1,5 m	kg	*5.050	2.150											
0,0 m	kg	5.500	2.200											
-1,5 m	kg	6.250	2.500											
-3,0 m	kg													
7,5 m	kg	*4.400	4.050											
6,0 m	kg	*4.100	2.850											
4,5 m	kg	*4.050	2.300											
3,0 m	kg	*4.200	2.000											
1,5 m	kg	*4.550	1.900											
0,0 m	kg	*4.900	1.950											
-1,5 m	kg	5.450	2.150											
-3,0 m	kg	*6.000	2.700											
7,5 m	kg	*2.800	*2.800											
6,0 m	kg	*2.600	2.450											
4,5 m	kg	*2.550	2.000											
3,0 m	kg	*2.650	1.750											
1,5 m	kg	*2.900	1.700											
0,0 m	kg	*3.250	1.700											
-1,5 m	kg	*3.950	1.850											
-3,0 m	kg	*5.250	2.250											
7,5 m	kg	*2.750	*2.750											
6,0 m	kg	*2.550	2.100											
4,5 m	kg	*2.550	1.750											
3,0 m	kg	*2.650	1.550											
1,5 m	kg	*2.850	1.450											
0,0 m	kg	*3.200	1.450											
-1,5 m	kg	*3.800	1.600											
-3,0 m	kg	*4.900	1.900											

Outrigger + blade	B	7,5 m	6,0 m	4,5 m	3,0 m	1,5 m	1.800 mm		2.400 mm		2.900 mm		3.500 mm	
							kg	kg	kg	kg	kg	kg	kg	kg
7,5 m	kg	*5.100	*5.100											
6,0 m	kg	*4.600	4.450											
4,5 m	kg	*4.500	3.500											
3,0 m	kg	*4.700	3.100											
1,5 m	kg	*5.100	2.950											
0,0 m	kg	5.500	3.050											
-1,5 m	kg	6.200	3.450											
-3,0 m	kg													
7,5 m	kg	*4.500	*4.500											
6,0 m	kg	*4.150	3.800											
4,5 m	kg	*4.100	3.100											
3,0 m	kg	*4.250	2.800											
1,5 m	kg	*4.600	2.650											
0,0 m	kg	4.850	2.700											
-1,5 m	kg	5.400	3.000											
-3,0 m	kg	*6.100	3.700											
7,5 m	kg	*2.850	*2.850											
6,0 m	kg	*2.650	*2.650											
4,5 m	kg	*2.600	*2.600											
3,0 m	kg	*2.700	2.500											
1,5 m	kg	*2.950	2.400											
0,0 m	kg	*3.350	2.400											
-1,5 m	kg	*4.000	2.650											
-3,0 m	kg	*5.350	3.150											
7,5 m	kg	*2.750	*2.750											
6,0 m	kg	*2.600	*2.600											
4,5 m	kg	*2.600	2.450											
3,0 m	kg	*2.700	2.200											
1,5 m	kg	*2.900	2.100											
0,0 m	kg	*3.250	2.150											
-1,5 m	kg	*3.850	2.300											
-3,0 m	kg	4.950	2.700											

Outrigger front + rear	B	7,5 m	6,0 m	4,5 m	3,0 m	1,5 m	1.800 mm		2.400 mm		2.900 mm		3.500 mm	
							kg	kg	kg	kg	kg	kg	kg	kg
7,5 m	kg	*5.100	*5.100											
6,0 m	kg	*4.600	*4.600											
4,5 m	kg	*4.500	4.350											
3,0 m	kg	*4.700	3.850											
1,5 m	kg	*5.100	3.700											
0,0 m	kg	5.650	3.800											
-1,5 m	kg	6.400	4.300											
-3,0 m	kg													
7,5 m	kg	*4.500	*4.500											
6,0 m	kg	*4.150	*4.150											
4,5 m	kg	*4.100	3.850											
3,0 m	kg	*4.250	3.450											
1,5 m	kg	*4.600	3.300											
0,0 m	kg	5.000	3.400											
-1,5 m	kg	5.550	3.750											
-3,0 m	kg	*6.100	4.650											
7,5 m	kg	*2.850	*2.850											
6,0 m	kg	*2.650	*2.650											
4,5 m	kg	*2.600	*2.600											
3,0 m	kg	*2.700	*2.700											
1,5 m	kg	*2.950	*2.950											
0,0 m	kg	*3.350	3.050											
-1,5 m	kg	*4.000	3.350											
-3,0 m	kg	*5.350	4.000											
7,5 m	kg	*2.750	*2.750											
6,0 m	kg	*2.600	*2.600											
4,5 m	kg	*2.600	*2.600											
3,0 m	kg	*2.700	*2.700											
1,5 m	kg	*2.900	2.700											
0,0 m	kg	*3.250	2.700											
-1,5 m	kg	*3.850	2.950											
-3,0 m	kg	*5.000	3.400											

# HYDRAULIC WHEELED EXCAVATOR

## STANDARD EQUIPMENT

- Komatsu SAA6D107E-1, 134 kW turbocharged common rail direct injection diesel engine, EU Stage IIIA compliant
- Double element type air cleaner with dust indicator and auto dust evacuator
- Suction type cooling fan
- Automatic fuel line de-aeration
- Engine key stop
- Engine ignition can be password secured on request
- Engine overheat prevention system
- Auto-deceleration function
- Automatic engine warm-up system
- Alternator 24 V/60 A
- Batteries 2 × 12 V/120 Ah
- Starter motor 24 V/5,5 kW
- Standard counterweight
- Electronic closed-centre load sensing (E-CLSS) hydraulic system (HydrauMind)
- Pump and engine mutual control (PEMC) system
- Multi-function colour monitor with equipment management monitoring system (EMMS)
- 4-working mode selection system; Power mode, economy mode, breaker mode and lifting mode
- PowerMax function
- Adjustable PPC wrist control levers with 3 button control and proportional attachment control slider for arm, boom, bucket and swing
- Additional hydraulic circuit (HCU-B)
- Fully automatic 3-speed transmission driving through front and rear planetary axles
- Orbitrol type hydraulic steering acting on front wheels
- Oscillating front axle (11°) with automatic and manual cylinder locking
- Dual circuit hydraulic brakes with outboard wet multi-disc service brakes
- Spring actuated park brake (hydraulic release) incorporated into transmission
- SpaceCab™, highly pressurized and tightly sealed viscous mounted cab with tinted safety glass windows, pull-up type front window with locking device, heated rear window, removable lower window, front window wiper with intermittent feature, sun blind roller, magazine rack behind seat, 12 V power supply, cigarette lighter, ashtray, floor mat, machine cab handrails, suspension seat with tiltable left hand console, automatic weight adjustment, adjustable arm rests and retractable seat belt, hot and cool box
- KOMTRAX™ Komatsu Tracking System
- Parts book and operator manual
- Lockable fuel cap and covers
- Fuel supply pump
- Overload warning device
- Boom safety valves
- Dozer blade cylinder guard
- Climate control/Air conditioning
- Centralised greasing system
- Radio cassette preparation
- Toolkit and spare parts for first service
- Single chassis tool box
- Standard colour scheme and decals
- 2,55 m wide undercarriage

## OPTIONAL EQUIPMENT

- Mono boom
- Two-piece boom
- 1,8 m; 2,4 m; 2,9 m; 3,5 m arms
- 2,75 m wide undercarriage
- Additional hydraulic circuit (HCU-C)
- Parallel blade (front and/or rear)
- 2 or 4 outriggers with cylinder protection (front and/or rear)
- Large bore bucket cylinders (1,8 m and 2,4 m arms only)
- Four sets of tyre and rim (twin tyre)
- 10.00-20 14 PR
- Four sets of tyre and rim (twin tyre) 11.00-20 16 PR
- Four sets of tyre and rim (single tyre) 18.00 R22
- Nokian twin tyres 10-20
- Nokian twin tyres 11-20
- Automatic greasing system
- Quick-coupler piping
- Komatsu quick couplers
- Komatsu buckets
- Transmission guard
- Clamshell grip bar
- Adjust cylinder safety valve
- Arm cylinder safety valve
- Heated air suspension seat
- Radio-cassette
- Lower wiper
- OPG Level II front guard (FOPS)
- OPG Level II top guard (FOPS)
- Additional RH boom lamp
- Beacon + rear facing cab lamp
- Additional large capacity cab roof lights (2)
- Bio oil
- Rain visor (not for use with OPG)
- Additional chassis tool box
- Customized paint



**Komatsu Europe International NV**  
 Mechelsesteenweg 586  
 B-1800 VILVOORDE (BELGIUM)  
 Tel. +32-2-255 24 11  
 Fax +32-2-252 19 81  
 www.komatsu.eu