



125t metric



186 kW

3300

Star-Lifter

Raupenkran

Crawler Crane



SEINEBOGEN[®]
Crane Line

SH/SH-S

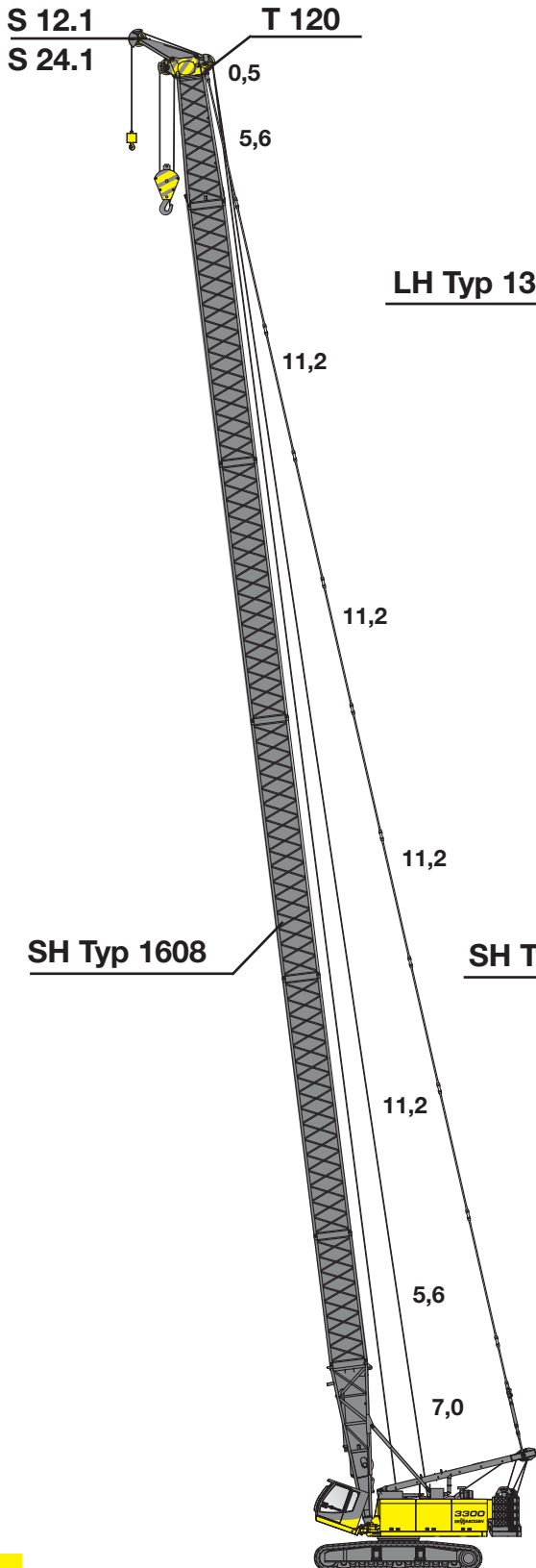

SH-LH / SH-LH-S

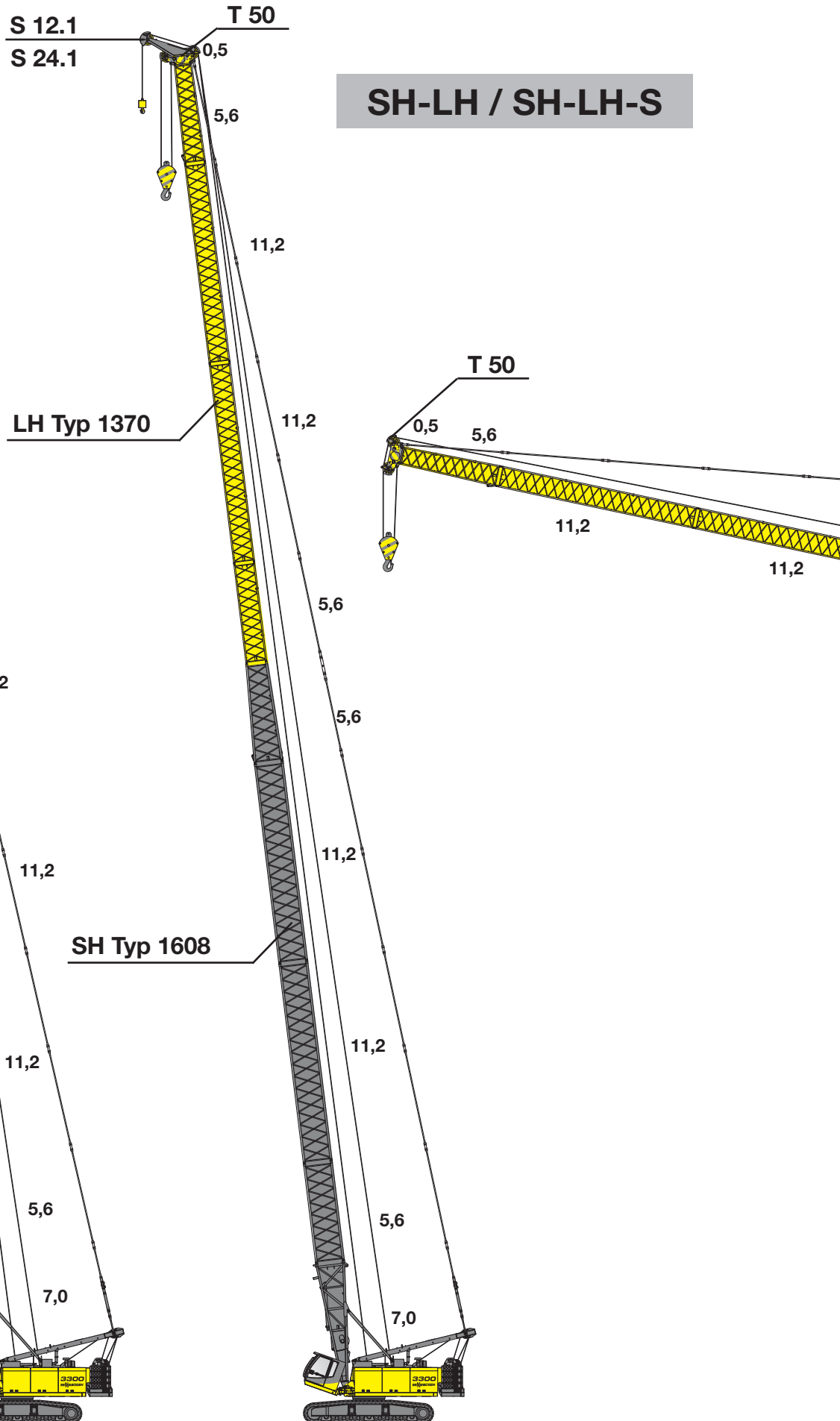

SH-WS

FS Typ 870

SH-LH-FS

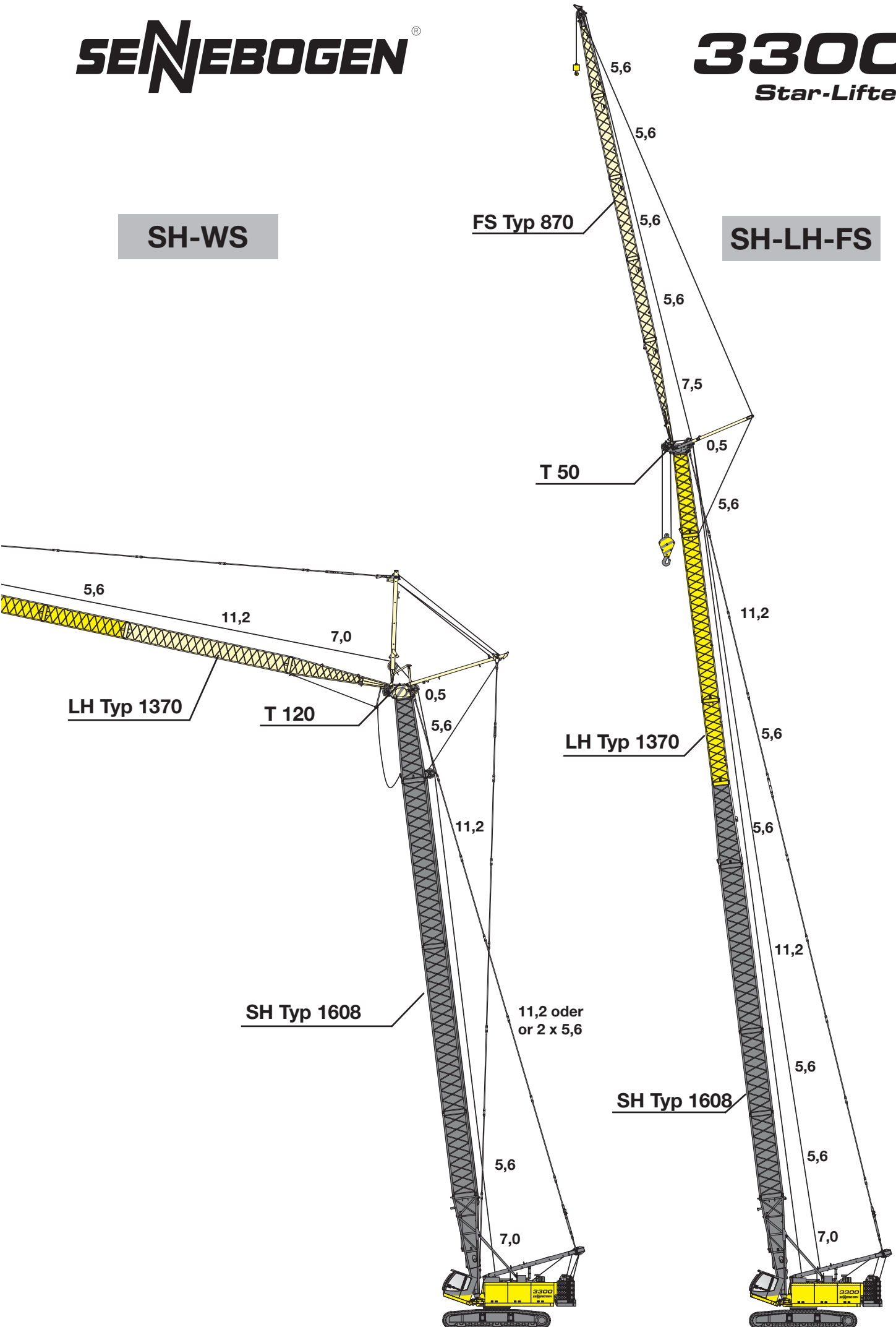

- Motorleistung 186 kW (249 PS)
- Moderne, leistungsfähige Hydraulikanlage
- Elektronische Grenzlastregelung
- Windenzugkraft 120 kN (max. 160 kN in der 1. Lage)
- Ausgezeichnete Feinfühligkeit und hohe Seilgeschwindigkeiten
- Robuste, sehr servicefreundliche Konzeption

Technische Daten

Motor

Caterpillar Dieselmotor C7 Tier III mit Direkteinspritzung, wassergekühlt, 186 kW (249 PS) bei 2000 min⁻¹

Trockenluftfilter mit Vorabscheidung, Haupt- und Sicherheitselement. Elektrische Anlage 24 Volt, Hochleistungs-Kaltstartbatterien. Kraftstoffsparende Leerlaufautomatik.

Kraftstofftankinhalt: ca. 830 l

Hydraulik

Alle Hydraulikpumpen sind Verstellpumpen mit Einzelregelung und energiesparender Bedarfstromsteuerung und Druckabschneidung.

Max. Fördermengen:
 310 l/min für Fahren und Winde 1
 310 l/min für Fahren und Winde 2
 230 l/min für Ausleger verstellen
 210 l/min für Drehen
 260 l/min für wippbaren Spitzenausleger
 Arbeitsdruck max. 330 bar.
 Hydrauliktankinhalt: ca. 750/580 l

Hydraulikölfilter mit Langzeitwechselintervall. Großdimensionierte Ölkühlanlage. Servosteuerelement nach ISO-System. Zentrales Servicetableau. Synthetische, umweltfreundliche Öle können verwendet werden. Hydro Clean Hydraulikfeinfilter mit Wasserabsorption. (Option)

Winde 1 - Winde 2

Antrieb der Winden über hochdruckgeregelte Verstellhydraulikmotore. Hydraulische Senk-Bremsventile für feinfühliges verschleißfreies Abbremsen. Starke Ölbad-Planetengetriebe wartungsarm. Kran- und Freifallbremse sind federbelastete, wartungsfreie, verschleißarme Lamellenbremsen im Ölbad laufend.

Winden	120 kN
max. Seilzug 1.Lage	160 kN
Seildurchmesser mm	26
Seilgeschwindigkeit m/min	0-140

Auf Wunsch:
Zusatzkranwinde

Drehantrieb

Antrieb über Hydraulikmotor mit Ölbad-Planetengetriebe. Federbelastete, hydraulisch löfzbare Sicherheitslamellenbremse, selbsteinfalld bei Stillstand. Starker, großdimensionierter 3-reihiger Rollendrehkranz Drehgeschwindigkeit 0 - 3 min⁻¹, 0 - 1,0 min⁻¹ für Kranbetrieb. Kraftübertragung durch 2 Drehgetriebe, dadurch geringere Flankenpressung und Momente. Feinschwenkschaltung über Vorwahlschalter.

Auslegerverstellung

Antrieb über separaten Hydraulikkreis über Axialkolbenmotor, federbelastete, hydraulisch löfzbare Lamellenbremse. Planetengetriebe und Windentrommel mit Spezialrillung. Zusätzlich automatische Ablaufsicherung. Max. Windenzugkraft 110 kN, Seildurchmesser 22 mm

Oberwagen

Verwindungssteifer Oberrahmen präzisionsbearbeitet. Übersichtliche, servicefreundliche Anordnung der Aggregate. Motor in SL (super-leise)-Version. Gegengewicht 38 t Vollhydraulische Ballastablegeeinrichtung

Unterwagen

Starker Breitspur-Raupenunterwagen. Hydraulischer Fahrentrieb mit Kompaktplanetengetriebe je Seite. Sicherheitslamellenbremse hydraulisch löfzbar. Wartungsfreies Traktorenlaufwerk mit hydraulischer Kettenspannung. Traktorenlaufwerk B8b mit 900 mm 3 Steg Bodenplatten. Option: Flachbodenplatten Fahrgeschwindigkeit: 0 - 1,8 km/h.

Arbeitsausrüstung

Rohrausleger 13,1 - 74,7 m, Doppelrollen-Hammerauslegerkopf, wippbarer Spitzenausleger, starrer Spitzenausleger, Schnabelausleger. Komplette Kransicherheitseinrichtung mit elektronischer Lastmomentbegrenzung.

Fahrerkabine

Komfortfahrerkabine F2000, elastisch gelagert mit Superschalldämmung, Großraumkabine mit ausgezeichnetem Rundum-Sicht, Allwetterausführung mit getöntem Sicherheitsglas, Frontscheibe mit Belüftungsposition unter das Dach einschiebbar, großes Dachfenster, Scheibenwischer-Waschanlage für Front- und Dachfenster, Front-Schutzblende, großes Ablagefach, ergonomisch gestalteter Komfortsitz elastisch gelagert, gewichts- und höhenstellbar, Sitzkissen mit Tiefen- und Neigungsverstellung, verstellbare Lendenwirbelstütze, breite, einstellbare Armlehnen, übersichtliches Armaturentableau mit ergonomisch geformten Steuerhebeln. Stufenlos regelbare Kabinenheizung, Frischluft- und Umluftstufe mit Partikelfilter. Fünf einstellbare Lüftungsdüsen für optimales Raumklima. Überwachung aller wichtigen Geräte und Motorfunktionen über das neue Diagnostik-System SDS mit optischer und akustischer Warnung bei Fehlfunktionen.

Hydraulische Kabinen-Neigung 20°. Hydraulische Kabinenschwenkeinrichtung - für Arbeitsposition und Transportposition.

Einsatzgewicht

3300 Star-Lifter - Laufwerk B8b, Laufwerkslänge 7150 mm, 2 x 120 kN Kranwinden, Dieselmotor 186 kW, 18,7 m Grundausleger, 38 t Gegengewicht Selbst-Montagesystem, Bodenplatten 900 mm

Einsatzgewicht **105 t**

Max. Einsatzgewicht mit max. Ausrüstung **119 t**

Die angegebenen Gewichte können sich durch verschiedene Ausstattungen verändern!

- Engine output 186 kW (249 HP)
- Very strong, state of the art hydraulic system
- Electronic speed sensing
- Line pull 120 kN (max. line pull in 1. Layer 160 kN)
- Precise control and high line speeds
- Robust, very service-friendly design

Specifications



Engine

Caterpillar diesel engine C7 Tier III with direct injection, water cooled 186 kW (249 HP) at 2000 rpm

Dry air filter with preliminary filter, main and safety element.
Electric system 24 Volt, high efficiency cold starting batteries. Idling speed function.

Fuel tank capacity: approx. 830 l



Hydraulic System

All hydraulic pumps are variable displacement piston pumps with individual regulation for each pump.

The pumps are equipped with an energy-saving flow-on-demand control system and pressure cut-off for high efficiency and reduced loss of energy.

Max. flow rates:

310 l/min for travel and winch 1
310 l/min for travel and winch 2
230 l/min for boom hoist
210 l/min for swing
260 l/min for luffing jib winch
Working pressure up to 330 bar.

Hydraulic tank capacity: approx. 750/580 l

Hydraulic filters with long intervals between change.

Large dimensioned hydraulic cooling system.

Servo-assisted joy-stick controls according to ISO-System.

Central service tableau.

Decomposable hydraulic oil (synthetic) can be used.

Hydro Clean hydraulic superfine filter with water absorption. (Option)



Winch 1 - Winch 2

Each winch is driven independently by a directly flanged variable displacement hydraulic piston motor with high pressure regulation. Hydraulic brake valves for wear resistant braking of loads. Strong low maintenance oil bath planetary gears. The clutch and brake functions are effected through large dimensioned, maintenance-free, low-wearing, oil-lubricated multiple disc brakes.

Winches	120 kN
max. Single line pull 1. Layer	160 kN
Rope dia.	mm 26
Line speed max.	m/min 0-140

Optional: Additional crane winch



Swing System

The swing function is operated through hydraulic piston motor with oil bath planetary gear. Spring-loaded hydraulically releasable multiple-disc brakes self-closing.

Large dimensioned triple roller type swing bearing.

Swing speed from 0 to 3 rpm, 0 to 1,0 rpm for crane operation.

Power transmission through 2 swing motors, thus less tooth pressure and moments. Precision swing operation with preselector switch.



Boom Hoist Operation

Hydraulically driven through a axial piston motor, spring-loaded hydraulically releasable multiple-disc brake, planetary gear and double winch drum with special scores.

Max. line pull 110 kN, rope diameter 22 mm. Drum pawl lock provides an integral drum lock.



Upper Structure

Torsion-free precision machined upper frame. All components are located clearly and service friendly. Engine with low noise level.

Counterweight 38 t

Hydraulic counterweight lowering system.



Undercarriage

Strong wide gauge crawler undercarriage. Each track is independently driven by an axial piston motor through planetary final drive. Spring loaded hydraulically releasable multiple-disc brake.

Maintenance-free tractor type crawler with hydraulic track-tensioning device.

Tractor type crawler B8b with 900 mm triple grouser shoes.

Optional: flat shoes
Travel speed: 0 - 1.8 km/h.



Working Equipment

Tubular boom 13.1-74.7 m, double sheave hammer head, luffing jib, fixed jib, auxiliary jib.

Complete crane safety device with electronic SLI safe load indicator



Operator's Cab

Comfortable F 2000 operator's cab, resiliently mounted, with exceptional sound suppression, large-capacity compartment with excellent allround visibility, all-weather design with tinted safety glass, front wind-screen with ventilation position stows under the roof, large-size skylight, window wiper/washer system for front windscreen and skylight, front guard panel, large-capacity stowage rack, ergonomically designed comfortable seat, resiliently mounted, adjustable in suspension and height, seat cushion adjustable in depth and angle, adjustable lumbar support, wide adjustable armrests, clearly laid out instrument panel with ergonomically shaped control levers, infinitely variable cab heating system, outside air and circulating air stages, with particle filter. Five adjustable air vents for optimum work environment.

New SDS diagnostic system for monitoring of all essential machine and engine functions, includes visual and audible warning of any malfunctions.

Hydraulically cab tilting system 20°.

Hydraulically cab swing mechanism – for working position and transport position.



Service Weight

3300 Star-Lifter - crawler B8b, length 7150 mm, 120 kN crane winches, engine 186 kW, 18,7 m basic boom, 38 t counterweight, self erection system, 900 mm shoes

Service weight **105 t**

Max. service weight with max. attachment **119 t**

The shown weights may vary with different equipment!

Subject to technical modification!

Hauptausleger - SH Main Boom - SH

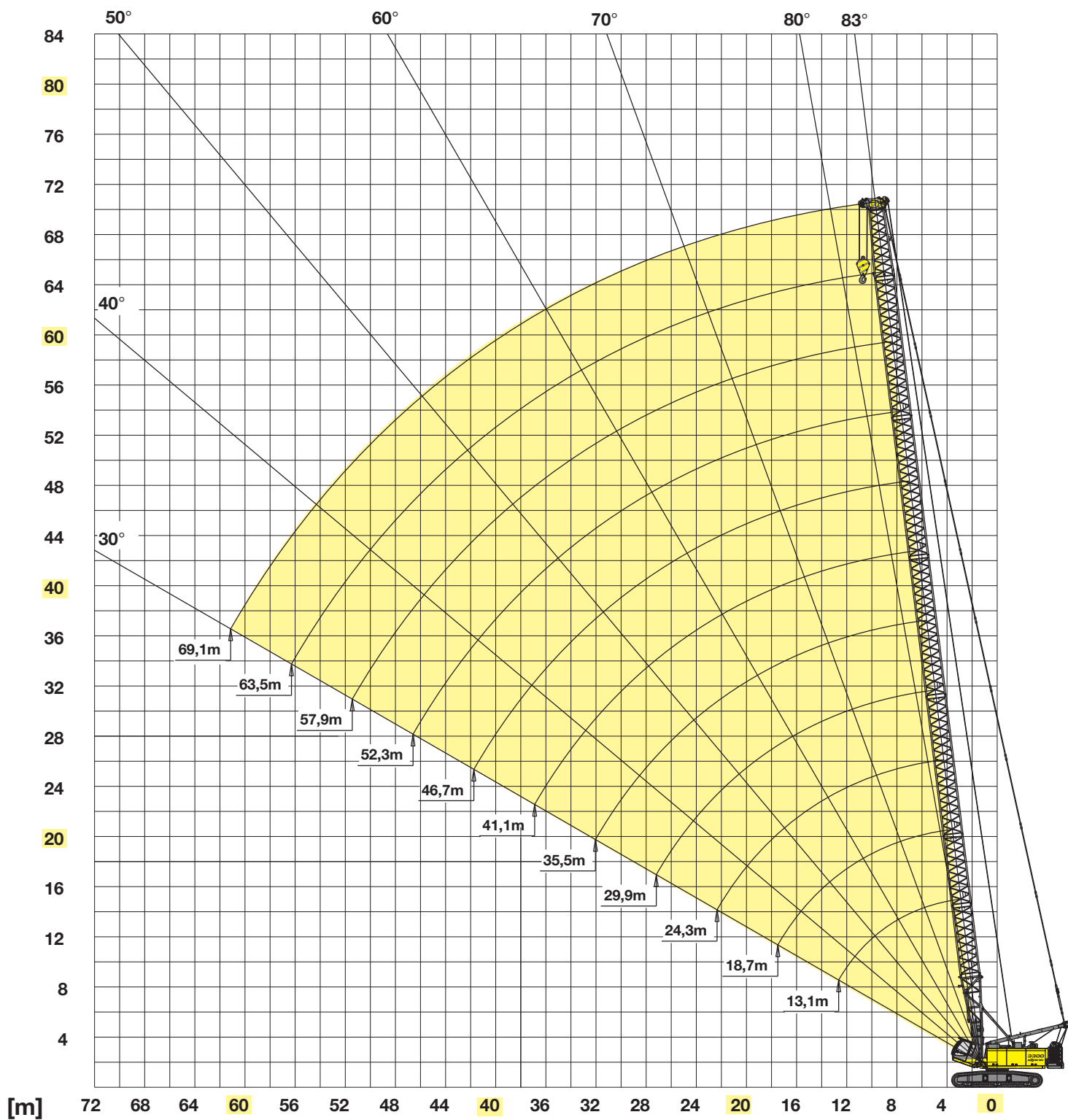

Auslegerzusammenbau siehe Seite 22
 Boom configuration see page 22

Traglasten - SH

Lifting capacities - SH

Gegengewicht 37,7 t

Counterweight 37,7 t

Ausladung Radius[m]	Auslegerlänge / boom length [m]										
	13,1	18,7	24,3	29,9	35,5	41,1	46,7	52,3	57,9	63,5	69,1
4,0	125,0*/110,0	106,0/4,6									
5,0	103,0	103,0	93,6/5,2	74,0/5,9							
6,0	85,0	84,9	80,3	73,2	59,5/6,6						
7,0	72,0	71,9	67,6	63,2	57,2	47,2/7,3					
8,0	58,3	58,2	58,0	54,9	51,6	44,9	38,0	30,4/8,7			
9,0	48,9	48,7	48,5	48,4	46,0	41,7	36,0	29,9	24,6/9,3		
10,0	42,0	41,8	41,5	41,3	41,2	38,6	33,9	28,6	24,0	19,3	15,6/10,7
11,0	36,7	36,5	36,2	36,0	35,9	35,4	31,8	27,2	23,1	18,7	15,4
12,0	32,5	32,3	32,0	31,8	31,7	31,5	29,8	25,9	22,2	18,1	15,0
13,0	29,2	28,9	28,6	28,4	28,2	28,1	27,7	24,6	21,3	17,5	14,6
14,0	28,8/13,1	26,1	25,8	25,6	25,4	25,2	24,9	23,3	20,4	16,9	14,2
15,0		23,8	23,5	23,3	23,1	22,9	22,5	22,0	19,5	16,3	13,8
16,0		21,8	21,5	21,3	21,1	20,9	20,5	20,3	18,6	15,7	13,3
17,0		20,2	19,8	19,5	19,3	19,1	18,8	18,6	17,7	15,2	12,9
18,0		18,7	18,3	18,0	17,8	17,6	17,2	17,1	16,7	14,6	12,5
19,0			17,0	16,7	16,5	16,3	15,9	15,7	15,4	14,0	12,1
20,0			15,9	15,6	15,3	15,1	14,7	14,6	14,2	13,4	11,6
22,0			14,0	13,6	13,4	13,1	12,8	12,6	12,2	12,0	10,8
24,0			13,3/22,8	12,0	11,8	11,5	11,1	10,9	10,6	10,4	10,0
26,0				10,8	10,5	10,2	9,8	9,6	9,2	9,1	8,7
28,0				9,9/ 27,7	9,3	9,1	8,7	8,5	8,1	7,9	7,6
30,0					8,4	8,1	7,7	7,5	7,1	6,9	6,6
32,0					7,6	7,3	6,9	6,7	6,3	6,1	5,7
34,0					7,4/32,5	6,6	6,2	5,9	5,6	5,4	5,0
36,0						6,0	5,6	5,3	4,9	4,7	4,4
38,0						5,6/37,4	5,0	4,8	4,4	4,2	3,8
40,0							4,5	4,3	3,9	3,7	3,3
42,0							4,1	3,8	3,4	3,2	2,8
44,0							4,1/42,2	3,4	3,0	2,8	2,4
46,0								3,1	2,7	2,4	2,0
48,0								2,9/47,1	2,3	2,1	1,7
50,0									2,0	1,8	1,4
52,0									1,8/51,9	1,5	1,1
54,0										1,3	0,9
56,0										1,1	
58,0										1,0/56,8	
60,0											
62,0											
64,0											
66,0											
68,0	TAB.-Nr. 3300R-75/2527/37.7/06.03 SH										
70,0											
Strangzahl / parts reeving	10	9	8	7	5	4	4	3	3	2	2

Anmerkungen:

- Die angegebenen Traglastwerte gelten für ebenen und festen Stand der Maschine.
- Traglastwerte sind in Tonnen angegeben und gelten für 360 Grad.
- Die Traglastwerte berücksichtigen die Normen DIN 15019/2 und ISO 4305 (Kippwinkel 4°)
- Das Gewicht der Lastaufnahmemittel (Haken, Gehänge) ist von den Traglasten abzuziehen.
- Die Traglastwerte gelten für maximale Unterwagenspurbreite.
- Lastwerte müssen begrenzt oder vermindert werden, um ungünstige Bedingungen zu berücksichtigen, wie weichen oder unebenen Boden, schräge Gefälle, Wind, Seitenlasten, schwingende Lasten, Rucken oder plötzliches Stoppen der Ladung, Unerfahrenheit des Personals, Fahren mit Last.
- Zulässiger Seilzug je Strang bei Kranbetrieb ist bei Seildurchmesser 26 mm - 12.000 kg
- Die Traglasten gelten für den Auslegerzusammenbau gemäß Bedienungsanleitung
- Traglastwerte gelten für optimalen Auslegerzusammenbau und Rollenkopf mit Kunststoffrollen.
- Die angegebenen Traglastwerte sind nur zur Orientierung. Die jeweils gültigen Traglastwerte entnehmen Sie bitte der Betriebsanleitung.
- Mit * gekennzeichnete Werte gelten nur mit Sonderausrüstung

Hauptausleger - SHLH

Mainboom - SHLH

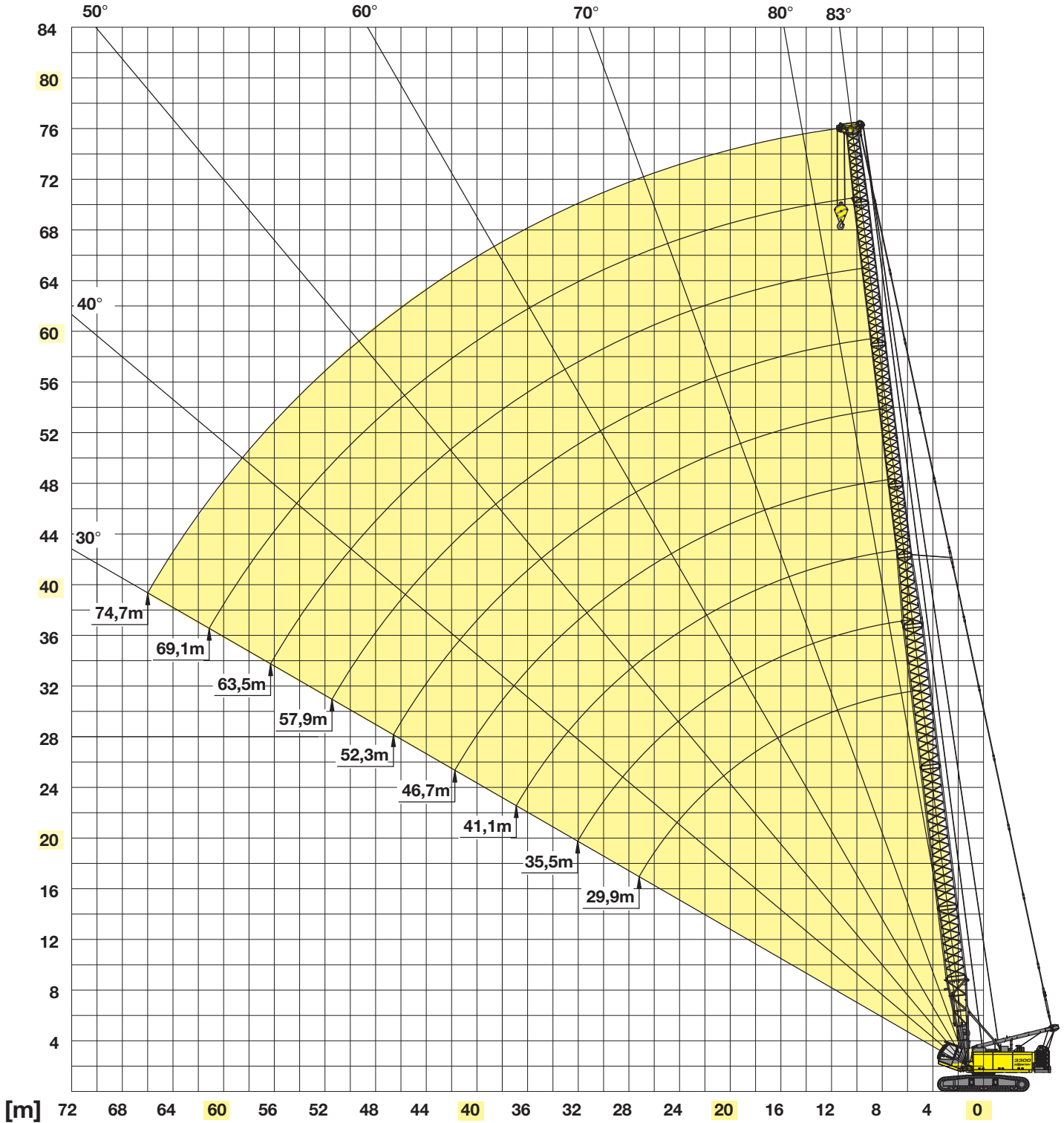

Auslegerzusammenbau siehe Seite 22
 Boom configuration see page 22

Traglasten - SHLH

Lifting capacities - SHLH

Gegengewicht 37,7 t

Counterweight 37.7t

Ausladung Radius[m]	Auslegerlänge / boom length [m]								
	29,9	35,5	41,1	46,7	52,3	57,9	63,5	69,1	74,7
4,0									
5,0	42,0 / 5,8								
6,0	41,6	39,0 / 6,5							
7,0	39,7	38,0	29,4 / 7,2	26,3 / 7,9					
8,0	37,7	36,3	28,5	26,1	19,0 / 8,5				
9,0	35,8	34,5	27,5	25,2	18,7	16,9 / 9,2	10,4 / 9,9		
10,0	33,9	32,7	26,5	24,4	18,3	16,6	10,4	8,9 / 10,6	
11,0	31,9	30,9	25,4	23,5	17,8	16,2	10,2	8,7	6,9 / 11,3
12,0	30,0	29,1	24,4	22,6	17,3	15,7	10,0	8,5	6,7
13,0	28,1	27,3	23,8	21,7	16,8	15,3	9,8	8,4	6,6
14,0	26,1	25,5	22,3	20,9	16,4	14,9	9,7	8,2	6,5
15,0	24,2	23,7	21,3	20,0	15,9	14,5	9,5	8,1	6,4
16,0	22,2	21,9	20,3	19,1	15,4	14,1	9,3	7,9	6,3
17,0	20,5	20,2	19,3	18,2	15,0	13,7	9,1	7,8	6,2
18,0	19,0	18,7	18,2	17,3	14,5	13,3	8,9	7,6	6,0
19,0	17,7	17,4	17,2	16,5	14,0	12,9	8,7	7,5	5,9
20,0	16,5	16,2	16,1	15,6	13,5	12,5	8,6	7,3	5,8
22,0	14,6	14,2	14,1	13,8	12,6	11,7	8,2	7,0	5,6
24,0	13,0	12,6	12,5	12,2	11,6	10,9	7,8	6,7	5,4
26,0	11,7	11,3	11,2	10,9	10,7	10,1	7,5	6,4	5,2
28,0	10,8 / 27,6	10,2	10,1	9,8	9,7	9,3	7,1	6,1	5,0
30,0		9,3	9,1	8,8	8,8	8,4	6,8	5,8	4,7
32,0		8,5	8,3	8,0	8,0	7,6	6,4	5,5	4,5
34,0		8,3 / 32,5	7,6	7,3	7,2	6,9	6,0	5,2	4,3
36,0			7,0	6,6	6,6	6,3	5,7	4,9	4,1
38,0			6,6 / 37,3	6,1	6,0	5,7	5,3	4,6	3,8
40,0				5,6	5,5	5,2	5,0	4,3	3,6
42,0				5,2	5,1	4,7	4,6	4,1	3,4
44,0				5,1 / 42,2	4,7	4,3	4,3	3,7	3,2
46,0					4,3	4,0	3,9	3,4	3,0
48,0					4,2 / 47,0	3,6	3,6	3,1	2,7
50,0						3,3	3,3	2,9	2,5
52,0						3,1 / 51,9	3,0	2,6	2,4
54,0							2,7	2,3	2,2
56,0							2,5	2,1	1,9
58,0							2,4 / 56,7	1,9	1,7
60,0								1,7	1,5
62,0								1,5 / 61,6	1,3
64,0									1,1
66,0									1,0
68,0	TAB.-Nr. 3300R-75/2527/37.7/06.03 SHLH								
70,0									0,9 / 66,4
Strangzahl / parts reeving	4	4	3	3	2	2	1	1	1

Notes:

- The rated loads shown are based on the machine on firm level ground and without travelling.
- The rated loads shown are in metric tons valid for 360 degrees swing.
- Liftcrane capacities are calculated to comply with DIN 15019 and ISO 4305 (tipping angle 4 deg.)
- The rated loads shown include the weight of all lifting attachments, such as hook and bucket.
- The rated loads shown are valid for a maximum track extension.
- The users must derate or limit the lifted loads to allow for adverse conditions such as soft or uneven ground, out of level conditions, wind side loads, pendulum action, jerking or sudden stopping of loads, inexperience of personnel and travelling with a load.
- Max. single line pull for crane operation with rope diameter 26 mm - 12.000 kg
- Loads are valid for the boom assembly acc. operation manual
- Lifting chart values apply to optimum boom assembly and rolley head with plasticsheaves.
- The lifting capacities above are for reference only. For actual lifting capacities please refer to load chart in operator's manual.
- Values marked with * are valid with special attachment"

Hauptausleger SHLH mit fester Spitze - FS

Main boom SHLH with fixed jib - FS

Auslegerzusammenbau siehe Seite 23
Boom configuration see page 23

Traglasten - SHLHFS
Lifting capacities - SHLHFS

Gegengewicht	37,7 t
Spitzenauslegerwinkel	5°/25°

Counterweight	37.7 t
Jib angle	5°/25°

Hauptausleger SH 85° mit wippbarem Spitzenausleger - WS
 Mainboom SH 85° with luffing jib - WS

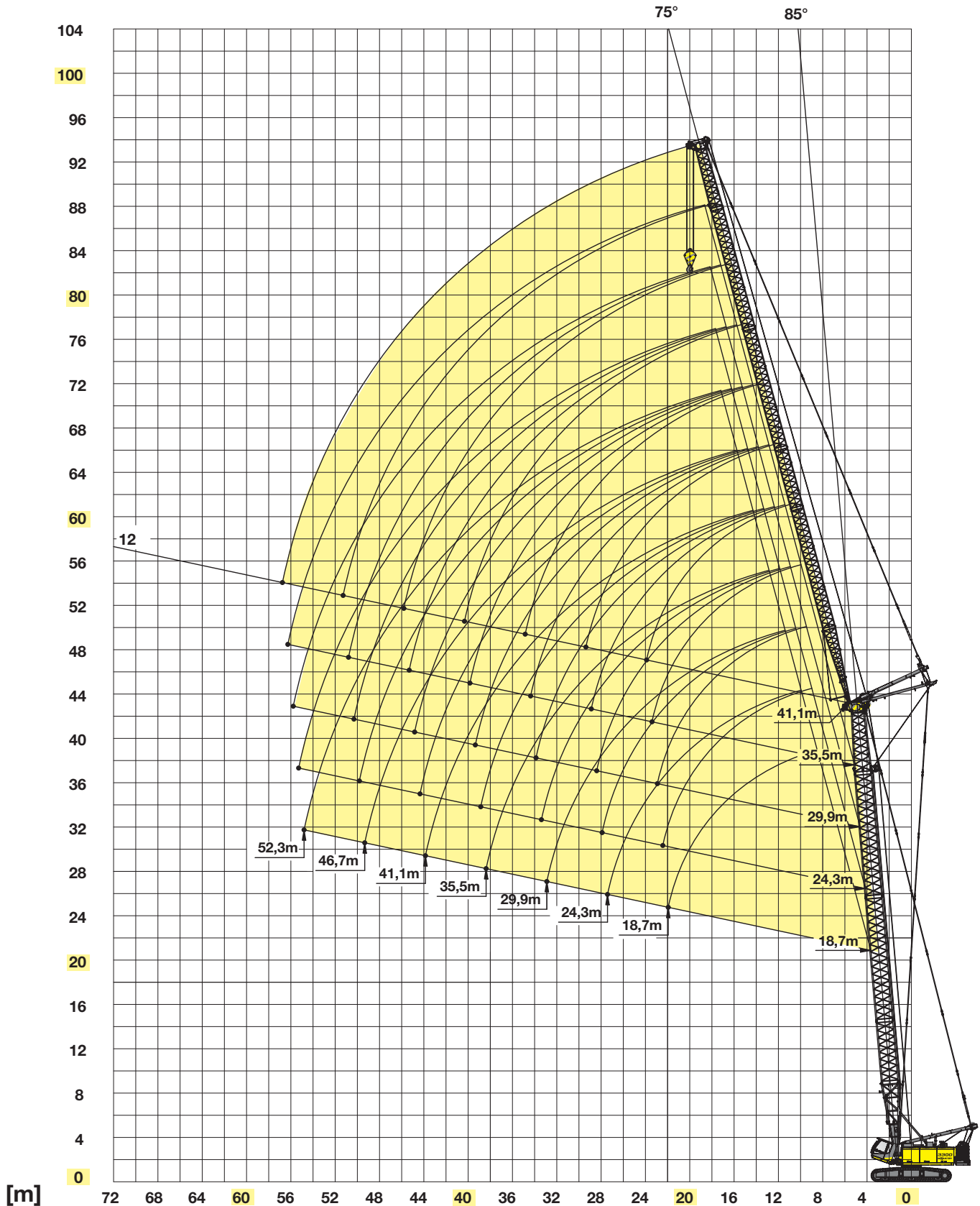

Auslegerzusammenbau siehe Seite 23
 Boom configuration see page 23

Traglasten - SHWS 85°

Lifting capacities - SHWS 85°

Gegengewicht 37,7 t
Hauptauslegerwinkel 85°

Counterweight 37.7 t
Main boom angle 85°

Ausladung Radius[m]	Hauptauslegerlänge / main boom length [m]																
	18,7							24,3							29,9		
	Spitzenauslegerlänge / luffing jib length [m]																
	18,7	24,3	29,9	35,5	41,1	46,7	52,3	18,7	24,3	29,9	35,5	41,1	46,7	52,3	18,7	24,3	29,9
9,0	37,0/9,3							33,0/9,8									
10,0	35,7	28,2/10,8						32,6									28,9/10,3
11,0	33,9	28,0						30,8	25,6/11,3								27,8 22,9/11,7
12,0	32,1	27,1	21,3/12,2					29,2	24,9	19,6/12,7							26,2 22,7
13,0	30,4	26,2	20,9	16,4/13,7				27,5	24,1	19,5							24,7 21,8 17,8/13,2
14,0	28,7	25,3	20,4	16,2				26,0	23,2	19,0	14,8/14,2						23,3 21,0 17,4
15,0	26,6	24,4	19,8	15,7	13,3/15,1			24,6	22,4	18,5	14,5						22,1 20,2 17,0
16,0	24,5	23,5	19,3	15,2	13,1	9,7/16,6		23,2	21,5	18,0	14,1	11,7/15,6					20,9 19,5 16,5
17,0	22,6	22,5	18,8	14,8	12,9	9,7		21,9	20,7	17,5	13,7	11,5	9,0/17,1				19,8 18,7 16,1
18,0	21,0	20,9	18,2	14,3	12,6	9,5	7,6	20,8	19,9	17,1	13,3	11,4	8,9	7,1/18,5			18,7 18,0 15,6
19,0	19,6	19,5	17,7	13,8	12,4	9,4	7,5	19,5	19,1	16,6	13,0	11,3	8,8	7,1			17,8 17,3 15,2
20,0	18,4	18,3	17,1	13,4	12,2	9,3	7,4	18,3	18,1	16,1	12,6	11,1	8,7	7,0			17,0 16,6 14,7
22,0	16,2	16,2	16,0	12,5	11,7	9,1	7,2	16,1	16,0	15,1	11,9	10,8	8,6	6,8			15,6 15,3 13,8
24,0	16,1/22,1	14,4	14,4	11,7	11,2	8,8	7,0	15,6/22,6	14,3	14,1	11,2	10,5	8,4	6,6	14,9/23,1	14,0	12,9
26,0		13,0	13,0	10,9	10,8	8,6	6,8		12,9	12,8	10,5	10,1	8,2	6,5			12,8 12,0
28,0		12,0/27,6	11,8	10,1	10,3	8,3	6,6		11,6	11,6	9,9	9,8	7,9	6,3			11,6 11,2
30,0			10,7	9,4	9,8	8,1	6,4		11,6/28,1	10,6	9,3	9,4	7,7	6,1			11,3/28,6 10,3
32,0			9,8	8,7	9,3	7,8	6,2			9,7	8,7	9,0	7,5	6,0			9,5
34,0			9,4/33,1	8,1	8,6	7,5	6,0			9,1/33,5	8,1	8,5	7,2	5,8			8,6
36,0				7,5	8,0	7,2	5,8				7,6	7,9	6,9	5,6			8,6/34,1
38,0				6,9	7,4	6,9	5,6				7,1	7,3	6,6	5,4			
40,0				6,8/38,6	6,8	6,6	5,5				6,8/39,0	6,8	6,3	5,2			
42,0					6,4	6,1	5,3					6,3	6,0	5,0			
44,0					5,9	5,7	5,1					5,9	5,6	4,8			
46,0						5,3	4,9					5,8/44,5	5,2	4,7			
48,0						4,9	4,7						4,8	4,5			
50,0						4,7	4,4						4,5	4,3			
52,0							4,1							4,0			
54,0								3,8						3,7			
56,0								3,7/55,0						3,5/55,5			
58,0																	
60,0																	
62,0																	
64,0																	
66,0																	
68,0																	
70,0																	
72,0	3300R-75/2527/37.7/06.03 SHWS 85																
74,0																	
76,0																	
78,0																	
Strangzahl / parts reeving	4	3	2	2	2	2	2	3	3	2	2	2	2	2	3	2	2

Notes:

- The rated loads shown are based on the machine on firm level ground and without travelling.
- The rated loads shown are in metric tons valid for 360 degrees swing.
- Liftcrane capacities are calculated to comply with DIN 15019,ISO 4305 (tipping angle 4 deg.)
- The rated loads shown include the weight of all lifting attachments,such as hook and bucket.
- The rated loads shown are valid for a maximum track extension.
- The users must derate or limit the lifted loads to allow for adverse conditions such as soft or uneven ground, out of level conditions, wind side loads, pendulum action, jerking or sudden stopping of loads, inexperience of personnel and travelling with a load.
- Max. single line pull for crane operation with rope diameter 26 mm - 12.000 kg
- Loads are valid for the boom assembly acc. operation manual
- Lifting chart values apply to optimum boom assembly and rolley head with plasticsheaves.
- The lifting capacities above are for reference only. For actual lifting capacities please refer to load chart in operator's manual.

Traglasten - SHWS 85°
Lifting capacities - SHWS 85°

Gegengewicht 37,7 t
Hauptauslegerwinkel 85°

Counterweight 37.7 t
Main boom angle 85°

Ausladung Radius[m]	Hauptauslegerlänge / main boom length [m]																		
	29,9				35,5								41,1						
	Spitzenauslegerlänge / luffing jib length [m]																		
	35,5	41,1	46,7	52,3	18,7	24,3	29,9	35,5	41,1	46,7	52,3	18,7	24,3	29,9	35,5	41,1	46,7	52,3	
9,0																			
10,0					24,6/10,8														
11,0					24,3							20,2/11,3							
12,0					23,0	20,0/12,2						19,5	17,0/12,7						
13,0					21,7	19,4	15,9/13,7					18,6	16,8						
14,0	13,4/14,6				20,6	18,6	15,7					17,8	16,1	14,0/14,2					
15,0	13,3				19,5	17,9	15,3	12,1/15,1				17,0	15,4	13,5	11,0/15,6				
16,0	13,0	10,5/16,1			18,5	17,1	14,8	11,8	9,4/16,6			16,2	14,7	13,0	10,9				
17,0	12,7	10,4	8,4/17,5		17,6	16,5	14,3	11,5	9,4			15,5	14,1	12,5	10,6	8,6/17,1			
18,0	12,3	10,4	8,4		16,7	15,8	13,9	11,3	9,3	7,6		14,9	13,5	12,0	10,2	8,5	6,9/18,5		
19,0	12,0	10,3	8,3	6,7	16,0	15,2	13,5	11,0	9,2	7,5	6,1/19,5	14,2	12,9	11,5	9,9	8,3	6,9		
20,0	11,7	10,2	8,2	6,6	15,3	14,6	13,0	10,7	9,1	7,5	6,1	13,7	12,4	11,1	9,6	8,2	6,8	5,6	
22,0	11,1	10,0	8,1	6,5	14,2	13,4	12,2	10,2	8,9	7,3	6,0	12,7	11,5	10,3	9,1	7,9	6,6	5,5	
24,0	10,6	9,7	7,9	6,3	13,5/23,6	12,4	11,4	9,6	8,7	7,2	5,8	11,8	10,6	9,5	8,6	7,6	6,5	5,4	
26,0	10,0	9,4	7,7	6,2		11,5	10,6	9,1	8,5	7,0	5,7	11,8/24,1	9,9	8,8	8,1	7,3	6,3	5,3	
28,0	9,5	9,1	7,5	6,0		10,7	9,9	8,7	8,2	6,9	5,6		9,4	8,2	7,6	7,0	6,1	5,2	
30,0	9,0	8,8	7,3	5,8		10,3/29,1	9,2	8,2	7,9	6,7	5,4		9,0/29,6	7,7	7,2	6,7	5,9	5,1	
32,0	8,4	8,5	7,1	5,7			8,6	7,8	7,6	6,5	5,3			7,3	6,8	6,4	5,7	4,9	
34,0	8,0	8,1	6,9	5,5			8,0	7,3	7,2	6,2	5,1			6,9	6,4	6,1	5,5	4,8	
36,0	7,5	7,6	6,6	5,3			7,8/34,5	6,9	6,9	6,0	5,0			6,8/35,0	6,0	5,8	5,3	4,6	
38,0	7,0	7,1	6,3	5,2				6,6	6,5	5,8	4,8				5,7	5,5	5,1	4,5	
40,0	6,7/39,5	6,6	6,1	5,0				6,2	6,1	5,5	4,6				5,5	5,1	4,8	4,3	
42,0		6,1	5,8	4,8					5,6	5,2	4,5				5,4/40,5	4,8	4,6	4,1	
44,0		5,7	5,4	4,6					5,2	4,9	4,3					4,5	4,3	3,9	
46,0		5,4/45,0	5,0	4,4					4,8/45,5	4,6	4,1					4,2	4,1	3,7	
48,0			4,7	4,2						4,3	3,9						3,8	3,5	
50,0			4,4	4,0						4,0	3,7						3,5	3,3	
52,0			4,3/50,5	3,8						3,8/51,0	3,5						3,3/51,5	3,1	
54,0				3,6							3,3							2,9	
56,0				3,4							3,0							2,6	
58,0											3,0/56,4							2,5/57,0	
60,0																			
62,0																			
64,0																			
66,0																			
68,0																			
70,0																			
72,0																			
74,0																			
76,0																			
78,0																			
Strangzahl / parts reeving	2	2	2	2	3	2	2	2	2	2	2	2	2	2	2	2	2	2	2

Anmerkungen:

- Die angegebenen Traglastwerte gelten für ebenen und festen Stand der Maschine.
- Traglastwerte sind in Tonnen angegeben und gelten für 360 Grad.
- Die Traglastwerte berücksichtigen die Normen DIN 15019/2, ISO 4305 (Kippwinkel 4°)
- Das Gewicht der Lastaufnahmemittel (Haken, Gehänge) ist von den Traglasten abzuziehen.
- Die Traglastwerte gelten für maximale Unterwagenspurbreite.
- Lastwerte müssen begrenzt oder vermindert werden, um ungünstige Bedingungen zu berücksichtigen, wie weichen oder unebenen Boden, schräge Gefälle, Wind, Seitenlasten, schwingende Lasten, Rucken oder plötzliches Stoppen der Ladung, Unerfahrenheit des Personals, Fahren mit Last.
- Zulässiger Seilzug je Strang bei Kranbetrieb ist bei Seildurchmesser 26 mm - 12.000 kg
- Die Traglasten gelten für den Auslegerzusammenbau gemäß Bedienungsanleitung
- Traglastwerte gelten für optimalen Auslegerzusammenbau und Rollenkopf mit Kunststoffrollen.
- Die angegebenen Traglastwerte sind nur zur Orientierung. Die jeweils gültigen Traglastwerte entnehmen Sie bitte der Betriebsanleitung.

Hauptausleger SH 75° mit wippbarerm Spitzenausleger - WS
Mainboom SH 75° with luffing jib - WS

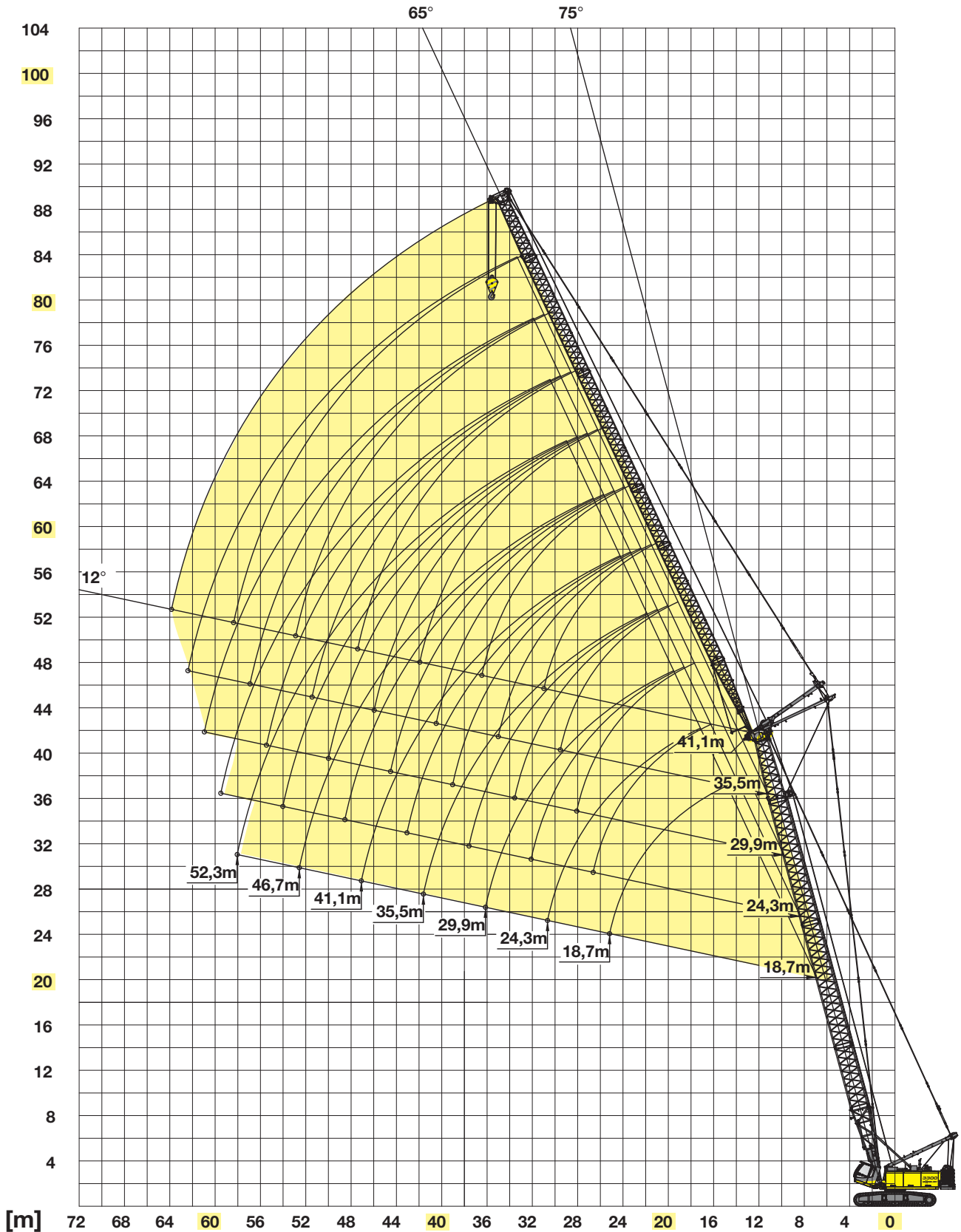

Auslegerzusammenbau siehe Seite 23
Boom configuration see page 23

Traglasten - SHWS 75°

Lifting capacities - SHWS 75°

Gegengewicht 37,7 t
Hauptauslegerwinkel 75°

Counterweight 37,7 t
Main boom angle 75°

Ausladung Radius[m]	Hauptauslegerlänge / main boom length [m]																	
	18,7						24,3						29,9					
	Spitzenauslegerlänge / luffing jib length [m]																	
	18,7	24,3	29,9	35,5	41,1	46,7	52,3	18,7	24,3	29,9	35,5	41,1	46,7	52,3	18,7	24,3	29,9	
9,0																		
10,0																		
11,0																		
12,0																		
13,0																		
14,0																		
15,0	23,0/15,6																	
16,0	22,3																	
17,0	20,8	19,0/17,9						19,9										
18,0	19,3	18,9						18,6							17,3/18,5			
19,0	18,0	17,8						17,4	16,6/19,4						16,8			
20,0	16,7	16,7	16,1/20,3					16,3	16,1	14,3/21,8					15,7	14,6/20,8		
22,0	14,7	14,8	14,7	13,5/22,7				14,3	14,3	14,1					13,9	13,7	12,5/23,2	
24,0	13,0	13,2	13,2	12,7	11,4/25,0			12,7	12,8	12,7	12,3/24,1				12,3	12,3	12,1	
26,0	12,3/25,3	11,7	11,9	11,5	11,0			11,4	11,5	11,5	11,2	10,3/26,5			11,1	11,1	10,9	
28,0		10,6	10,7	10,5	10,1	8,3	6,2/29,8	11,0/26,8	10,3	10,3	10,1	9,7	7,7/28,9		10,1	10,0	9,8	
30,0		9,7	9,7	9,5	9,3	7,9	6,2		9,4	9,4	9,2	8,9	7,5	5,8/31,2	10,0/28,3	9,0	8,9	
32,0		9,4/30,8	8,8	8,7	8,6	7,5	6,0		8,6	8,5	8,3	8,1	7,1	5,7		8,2	8,2	
34,0			8,1	7,9	7,9	7,1	5,9		8,6/32,3	7,8	7,6	7,4	6,7	5,6		7,7/33,7	7,5	
36,0			7,5	7,3	7,3	6,7	5,8			7,2	6,9	6,8	6,4	5,4			6,9	
38,0			7,4/36,3	6,7	6,7	6,4	5,6			6,8/37,8	6,4	6,3	6,0	5,3			6,4	
40,0				6,2	6,2	5,9	5,4				5,9	5,8	5,5	5,1			6,1/39,2	
42,0				5,9/41,8	5,7	5,4	5,2				5,6	5,4	5,1	4,8				
44,0					5,3	5,0	4,8				5,3/43,2	5,0	4,7	4,4				
46,0					5,0	4,7	4,4					4,6	4,3	4,1				
48,0					4,8/47,3	4,3	4,1					4,3	4,0	3,8				
50,0						4,0	3,8					4,2/48,7	3,7	3,5				
52,0							3,8	3,5					3,5	3,2				
54,0							3,7/52,7	3,3					3,2	3,0				
56,0								3,0					3,2/54,2	2,8				
58,0								2,8						2,6				
60,0								2,8/58,2						2,4/59,7				
62,0																		
64,0																		
66,0																		
68,0																		
70,0																		
72,0	Tab.-Nr.: 3300R-75/2527/37.7/06.03 SHWS 75																	
74,0																		
76,0																		
78,0																		
Strangzahl / parts reeving	4	3	2	2	2	2	2	3		2	2	2	2	2	32		2	

Anmerkungen:

- Die angegebenen Traglastwerte gelten für ebenen und festen Stand der Maschine.
- Traglastwerte sind in Tonnen angegeben und gelten für 360 Grad.
- Die Traglastwerte berücksichtigen die Normen DIN 15019/2, ISO 4305 (Kippwinkel 4°)
- Das Gewicht der Lastaufnahmemittel (Haken, Gehänge) ist von den Traglasten abzuziehen.
- Die Traglastwerte gelten für maximale Unterwagensepurbreite.
- Lastwerte müssen begrenzt oder vermindert werden, um ungünstige Bedingungen zu berücksichtigen, wie weichen oder unebenen Boden, schräge Gefälle, Wind, Seitenlasten, schwingende Lasten, Rucken oder plötzliches Stoppen der Ladung, Unerfahrenheit des Personals, Fahren mit Last.
- Zulässiger Seilzug je Strang bei Kranbetrieb ist bei Seildurchmesser 26 mm - 12.000 kg
- Die Traglasten gelten für den Auslegerzusammenbau gemäß Bedienungsanleitung
- Traglastwerte gelten für optimalen Auslegerzusammenbau und Rollenkopf mit Kunststoffrollen.
- Die angegebenen Traglastwerte sind nur zur Orientierung. Die jeweils gültigen Traglastwerte entnehmen Sie bitte der Betriebsanleitung.

Traglasten - SHWS 75°

Lifting capacities - SHWS 75°

Gegengewicht 37,7 t
Hauptauslegerwinkel 75°

Counterweight 37.7 t
Main boom angle 75°

Ausladung Radius[m]	Hauptauslegerlänge / main boom length [m]																	
	29,9					35,5					41,1							
	Spitzenauslegerlänge / luffing jib length [m]																	
	35,5	41,1	46,7	52,3	18,7	24,3	29,9	35,5	41,1	46,7	52,3	18,7	24,3	29,9	35,5	41,1	46,7	52,3
9,0																		
10,0																		
11,0																		
12,0																		
13,0																		
14,0																		
15,0																		
16,0																		
17,0																		
18,0																		
19,0																		
20,0					15,1/19,9							13,2/21,4						
22,0					13,3	12,8/22,3						12,7	11,2/23,7					
24,0	10,8/25,6				11,8	11,7	11,0/24,7					11,3	11,0					
26,0	10,6				10,6	10,5	10,2	9,4/27,0				10,1	9,9	9,5/26,1				
28,0	9,5	9,2			9,6	9,5	9,2	8,9	8,0/29,4			9,2	8,9	8,6	8,1/28,5			
30,0	8,6	8,4	7,1/30,3		8,8/29,7	8,6	8,4	8,1	7,8	6,5/31,8		8,3	8,1	7,8	7,5	6,9/30,8		
32,0	7,9	7,6	6,8	5,5/32,7		7,8	7,7	7,4	7,1	6,4		7,9/31,1	7,4	7,1	6,8	6,5	5,8/33,2	
34,0	7,2	7,0	6,4	5,4		7,2	7,0	6,7	6,5	6,0	5,0/34,1		6,8	6,5	6,2	5,9	5,6	4,7/35,6
36,0	6,6	6,4	6,0	5,2		6,9/35,2	6,4	6,2	5,9	5,6	4,8		6,2	6,0	5,7	5,4	5,1	4,6
38,0	6,1	5,9	5,6	5,0			5,9	5,7	5,4	5,1	4,6		6,0/36,6	5,5	5,2	4,9	4,6	4,3
40,0	5,6	5,4	5,1	4,8			5,5	5,2	5,0	4,7	4,4			5,1	4,8	4,5	4,2	3,9
42,0	5,2	5,0	4,7	4,4			5,4/40,7	4,8	4,6	4,3	4,0			4,7	4,4	4,1	3,8	3,5
44,0	4,9	4,6	4,3	4,1				4,5	4,2	3,9	3,7			4,7/42,1	4,1	3,8	3,5	3,2
46,0	4,7/44,7	4,3	4,0	3,7				4,2	3,9	3,6	3,3				3,8	3,5	3,2	2,9
48,0		4,0	3,7	3,4				4,1/46,1	3,6	3,3	3,1				3,6/47,6	3,2	2,9	2,6
50,0		3,7	3,4	3,1					3,3	3,0	2,8					3,0	2,7	2,4
52,0		3,7/50,2	3,2	2,9					3,2/51,6	2,8	2,5					2,8	2,4	2,2
54,0			2,9	2,7						2,6	2,3					2,7/53,0	2,2	2,0
56,0			2,8/55,6	2,5						2,4	2,1						2,0	1,8
58,0				2,3						2,3/57,1	1,9						1,9	1,6
60,0				2,1							1,8						1,8/58,5	1,4
62,0				2,0/61,1							1,7							1,3
64,0											1,6/62,6							1,2
66,0																		
68,0																		
70,0																		
72,0																		
74,0																		
76,0																		
78,0																		
Strangzahl / parts reeving	22		2	2	3	2	22		2	2	2	2	2	2	2	2	2	2

Notes:

- The rated loads shown are based on the machine on firm level ground and without travelling.
- The rated loads shown are in metric tons valid for 360 degrees swing.
- Liftcrane capacities are calculated to comply with DIN 15019,ISO 4305 (tipping angle 4 deg.)
- The rated loads shown include the weight of all lifting attachments,such as hook and bucket.
- The rated loads shown are valid for a maximum track extension.
- The users must derate or limit the lifted loads to allow for adverse conditions such as soft or uneven ground, out of level conditions, wind side loads, pendulum action, jerking or sudden stopping of loads, inexperience of personnel and travelling with a load.
- Max. single line pull for crane operation with rope diameter 26 mm - 12.000 kg
- Loads are valid for the boom assembly acc. operation manual
- Lifting chart values apply to optimum boom assembly and rolley head with plasticsheaves.
- The lifting capacities above are for reference only. For actual lifting capacities please refer to load chart in operator's manual.

Hauptausleger SH 65° mit wippbarem Spitzenausleger - WS

Mainboom SH 65° with luffing jib - WS

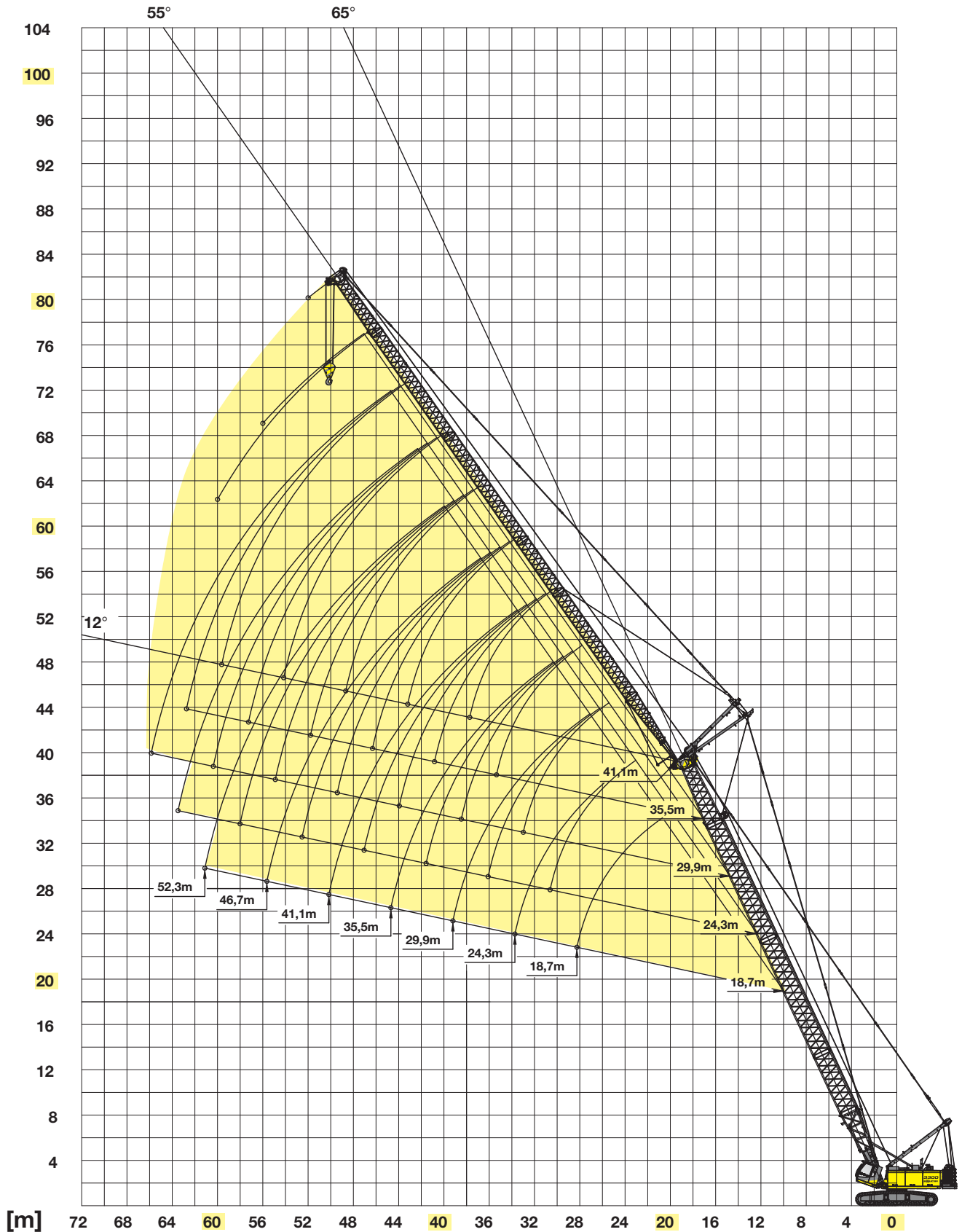

Auslegerzusammenbau siehe Seite 23

Boom configuration see page 23

Traglasten - SHWS 65°

Lifting capacities - SHWS 65°

Gegengewicht 37,7 t
Hauptauslegerwinkel 65°

Counterweight 37.7 t
Main boom angle 65°

Ausladung Radius[m]	Hauptauslegerlänge / main boom length [m]																	
	18,7							24,3							29,9			
	Spitzenauslegerlänge / luffing jib length [m]																	
	18,7	24,3	29,9	35,5	41,1	46,7	52,3	18,7	24,3	29,9	35,5	41,1	46,7	52,3	18,7	24,3	29,9	
9,0																		
10,0																		
11,0																		
12,0																		
13,0																		
14,0																		
15,0																		
16,0																		
17,0																		
18,0																		
19,0																		
20,0	14,3/21,4																	
22,0	13,8							11,7/23,8										
24,0	12,4	11,7/24,6						11,5										
26,0	11,1	11,0	9,8/27,8					10,5	9,6/27,0						9,4/26,1			
28,0	10,1	10,0	9,7					9,5	9,1						8,6	7,9/29,3		
30,0	9,9/28,4	9,1	8,9	8,2/31,0				8,6	8,3	8,1/30,2					7,8	7,6		
32,0		8,3	8,1	7,9				8,2/30,8	7,6	7,5	6,7/33,4				7,1	7,0	6,6/32,5	
34,0		7,6/33,9	7,5	7,3	6,9/34,2				7,0	6,9	6,5				6,8/33,1	6,5	6,2	
36,0			6,9	6,7	6,4	5,7/37,4			6,4	6,3	6,0	5,6/36,6				5,9	5,7	
38,0			6,4	6,1	5,9	5,5			6,3/36,3	5,8	5,5	5,3	4,6/39,8			5,4	5,3	
40,0			6,1/39,4	5,7	5,4	5,1	4,7/40,7			5,3	5,1	4,9	4,5			5,3/38,6	4,8	
42,0				5,2	5,0	4,7	4,5			5,0/41,7	4,7	4,5	4,1	3,7/43,0			4,5	
44,0				4,8	4,6	4,4	4,1				4,4	4,1	3,8	3,6			4,1	
46,0				4,7/44,8	4,3	4,0	3,8				4,1	3,8	3,5	3,3			4,1/44,1	
48,0					4,0	3,7	3,5				3,9/47,2	3,5	3,2	3,0				
50,0					3,8	3,5	3,2					3,2	3,0	2,8				
52,0					3,7/50,3	3,2	2,9					3,0	2,7	2,6				
54,0						3,0	2,7					2,9/52,7	2,5	2,3				
56,0						2,8/55,8	2,5						2,3	2,1				
58,0							2,3						2,2	1,9				
60,0							2,2						2,1/58,2	1,8				
62,0							2,0/61,3							1,6				
64,0														1,5/63,6				
66,0																		
68,0																		
70,0																		
72,0	Tab.-Nr.: 3300R-75/2527/37.7/06.03 SHWS 65																	
74,0																		
76,0																		
78,0																		
Strangzahl / parts reeving	4	3	2	2	2	2	2	3	3	2	2	2	2	2	3	2	2	

Anmerkungen:

- Die angegebenen Traglastwerte gelten für ebenen und festen Stand der Maschine.
- Traglastwerte sind in Tonnen angeben und gelten für 360 Grad.
- Die Traglastwerte berücksichtigen die Normen DIN 15019/2, ISO 4305 (Kippwinkel 4°)
- Das Gewicht der Lastaufnahmemittel (Haken, Gehänge) ist von den Traglasten abzuziehen.
- Die Traglastwerte gelten für maximale Unterwagenspurbreite.
- Lastwerte müssen begrenzt oder vermindert werden, um ungünstige Bedingungen zu berücksichtigen, wie weichen oder unebenen Boden, schräge Gefälle, Wind, Seitenlasten, schwingende Lasten, Rucken oder plötzliches Stoppen der Ladung, Unerfahrenheit des Personals, Fahren mit Last.
- Zulässiger Seilzug je Strang bei Kranbetrieb ist bei Seildurchmesser 26 mm - 12.000 kg
- Die Traglasten gelten für den (Auslegerzusammenbau gemäß Bedienungsanleitung
- Traglastwerte gelten für optimalen Auslegerzusammenbau und Rollenkopf mit Kunststoffrollen.
- Die angegebenen Traglastwerte sind nur zur Orientierung. Die jeweils gültigen Traglastwerte entnehmen Sie bitte der Betriebsanleitung.

Traglasten - SHWS 65°

Lifting capacities - SHWS 65°

Gegengewicht 37,7 t
Hauptauslegerwinkel 65°

Counterweight 37.7 t
Main boom angle 65°

Ausladung Radius[m]	Hauptauslegerlänge / main boom length [m]																	
	29,9				35,5								41,1					
	Spitzenauslegerlänge / luffing jib length [m]																	
	35,5	41,1	46,7	52,3	18,7	24,3	29,9	35,5	41,1	46,7	52,3	18,7	24,3	29,9	35,5	41,1	46,7	52,3
9,0																		
10,0																		
11,0																		
12,0																		
13,0																		
14,0																		
15,0																		
16,0																		
17,0																		
18,0																		
19,0																		
20,0																		
22,0																		
24,0																		
26,0																		
28,0					7,3/28,5													
30,0					6,9	6,3/31,7						6,0/30,9						
32,0					6,3	6,2						5,7						
34,0	5,4/35,8				5,8	5,6	5,1/34,9					5,2	4,8/34,1					
36,0	5,3				5,4/35,5	5,1	4,9					4,7	4,4	3,9/37,3				
38,0	4,9	4,4/39,0				4,7	4,5	4,1/38,1				4,4/37,9	4,0	3,8				
40,0	4,6	4,2				4,4	4,2	3,8	3,3/41,3				3,7	3,5	3,0/40,5			
42,0	4,2	3,9	3,5/42,2			4,2/41,0	3,8	3,5	3,2				3,4	3,2	2,8	2,3/43,7		
44,0	3,9	3,6	3,3	2,7/45,4			3,5	3,2	3,0	2,5/44,5			3,2/43,4	2,9	2,6	2,3		
46,0	3,6	3,3	3,0	2,7			3,2	2,9	2,7	2,3	1,8/47,8			2,6	2,3	2,0	1,6/46,9	
48,0	3,3	3,0	2,7	2,4			3,2/46,5	2,7	2,5	2,1	1,8			2,4	2,1	1,8	1,5	
50,0	3,1/49,6	2,8	2,5	2,2				2,5	2,2	1,9	1,6			2,3/48,8	1,9	1,6	1,3	1,0/50,1
52,0		2,6	2,3	2,0				2,3	2,0	1,7	1,4				1,7	1,5	1,1	0,8
54,0		2,4	2,1	1,8					1,8	1,5	1,3				1,6	1,3	1,0	
56,0		2,3/55,1	1,9	1,6					1,7	1,4	1,1				1,6/54,3	1,2	0,8	
58,0			1,8	1,5					1,5/57,4	1,2	0,9					1,0		
60,0			1,6	1,3						1,1	0,8					0,9/59,8		
62,0			1,5/60,6	1,2							1,0							
64,0				1,0							0,9/62,9							
66,0				0,9														
68,0																		
70,0																		
72,0																		
74,0																		
76,0																		
78,0																		
Strangzahl / parts reeving	2	2	2	2	3	2	2	2	2	2	2	2	2	2	2	2	2	2

Notes:

1. The rated loads shown are based on the machine on firm level ground and without travelling.
2. The rated loads shown are in metric tons valid for 360 degrees swing.
3. Liftcrane capacities are calculated to comply with DIN 15019,ISO 4305 (tipping angle 4 deg.)
4. The rated loads shown include the weight of all lifting attachments,such as hook and bucket.
5. The rated loads shown are valid for a maximum track extension.
6. The users must derate or limit the lifted loads to allow for adverse conditions such as soft or uneven ground, out of level conditions, wind side loads, pendulum action, jerking or sudden stopping of loads, inexperience of personnel and travelling with a load.
7. Max. single line pull for crane operation with rope diameter 26 mm - 12.000 kg
8. Loads are valid for the boom assembly acc. operation manual
9. Lifting chart values apply to optimum boom assembly and rolley head with plasticsheaves.
10. The lifting capacities above are for reference only. For actual lifting capacities please refer to load chart in operator's manual.

Zusatzausrüstungen Attachments

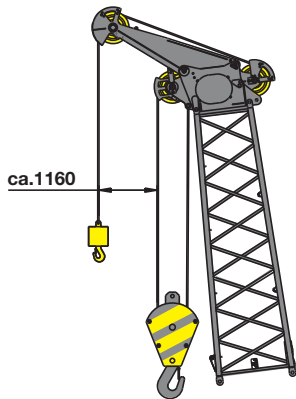

Hauptausleger SH mit Schnabelausleger S12.1(12t)
Main boom SH with Auxiliary jib S12.1(12t)

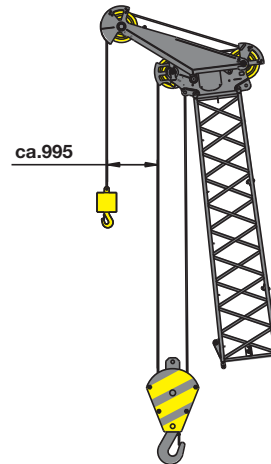

Hauptausleger SHLH mit Schnabelausleger S12.1(12t)
Main boom SHLH with Auxiliary jib S12.1(12t)

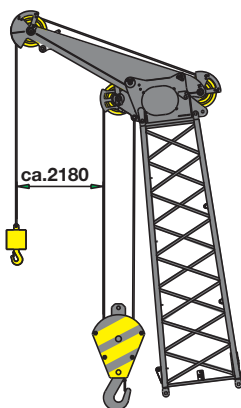

Hauptausleger SH mit Schnabelausleger S24.1(24t)
Main boom SH with Auxiliary jib S24.1(24t)

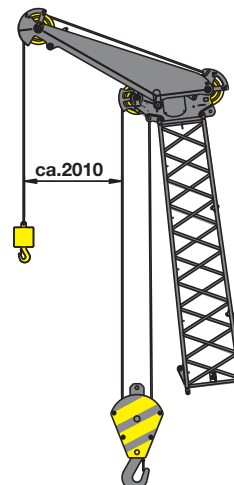

Hauptausleger SHLH mit Schnabelausleger S24.1(24t)
Main boom SHLH with Auxiliary jib S24.1(24t)

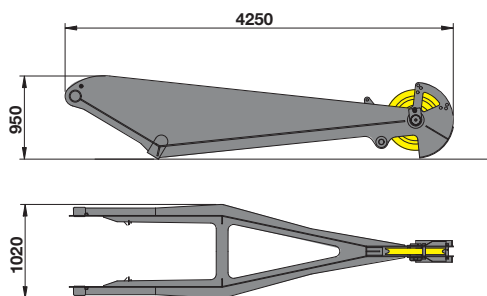

Schnabelausleger: S24.1
auxilliary jib: S24.1

Gewicht: 510 kg
weight: 510 kg
Traglast: 24,0t
capacity: 24.0t

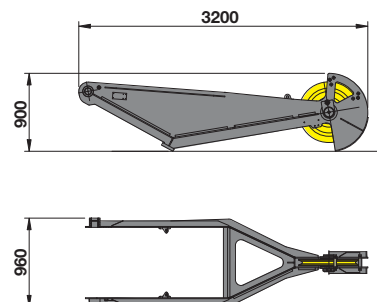

Schnabelausleger: S12.1
auxilliary jib: S12.1

Gewicht: 370 kg
weight: 370 kg
Traglast 12,0t
capacity: 12.0t

Auslegerkonfiguration Boom Configuration

Auslegerkonfiguration - Hauptausleger SH boom configuration - main boom SH												
Auslegerlänge [m] boom length [m]		13,1	18,7	24,3	29,9	35,5	41,1	46,7	52,3	57,9	63,5	69,1
Fußstück SH Typ 1608 lower boom SH type 1608	7,0m	1	1	1	1	1	1	1	1	1	1	1
Zwischenstück SH Typ 1608 boom insert SH type 1608	5,6m	0	1	2	1	2	1	2	1	2	1	2
Zwischenstück SH Typ 1608 boom insert SH type 1608	11,2m	0	0	0	1	1	2	2	3	3	4	4
Zwischenstück konisch SH Typ 1608/1370 tapered boom insert SH type 1608/1370	5,6m	1	1	1	1	1	1	1	1	1	1	1
Rollenkopf T120 boom head T120	0,5m	1	1	1	1	1	1	1	1	1	1	1
Schnabelausleger S12.1 (optional) auxiliary jib S12.1 (option)	12,0t	x	x	x	x	x	x	x	x	x	x	-
Schnabelausleger S24.1 (optional) auxiliary jib S24.1 (option)	24,0t	x	x	x	x	x	x	x	x	x	x	-

Auslegerkonfiguration - Hauptausleger SHLH boom configuration - main boom SHLH											
Auslegerlänge [m] boom length [m]		29,9	35,5	41,1	46,7	52,3	57,9	63,5	69,1	74,7	
Fußstück SH Typ 1608 lower boom SH type 1608	7,0m	1	1	1	1	1	1	1	1	1	
Zwischenstück SH Typ 1608 boom insert SH type 1608	5,6m	1	2	2	1	1	2	2	1	1	
Zwischenstück SH Typ 1608 boom insert SH type 1608	11,2m	0	0	0	1	1	1	1	2	2	
Zwischenstück konisch SH Typ 1608/1370 tapered boom insert SH type 1608/1370	5,6m	1	1	1	1	1	1	1	1	1	
Zwischenstück LH Typ 1370 boom insert LH type 1370	5,6m	1	1	2	2	1	1	2	2	1	
Zwischenstück LH Typ 1370 boom insert LH type 1370	11,2m	0	0	0	0	1	1	1	1	2	
Zwischenstück konisch LH Typ 1370/610 tapered boom insert LH type 1370/610	5,6m	1	1	1	1	1	1	1	1	1	
Rollenkopf T50 boom head T50	0,5m	1	1	1	1	1	1	1	1	1	
Schnabelausleger S12.1 (optional) auxiliary jib S12.1 (option)	12,0t	x	x	x	x	x	x	x	x	x	
Schnabelausleger S24.1 (optional) auxiliary jib S24.1 (option)	24,0t	x	x	x	x	x	x	x	x	x	

Haken Hooks

Für 160 kN Winde mit 26 mm Seildurchmesser - For 160 kN winch with 26 mm rope diameter

Kapazität capacity	Gewicht weight	Seilstränge und max. Traglast - Nr. of ropes and max. rated load													
		14	13	12	11	10	9	8	7	6	5	4	3	2	1
15 t	450 kg														12.000
40 t - 1 Rolle	900 kg												36.000	24.000	12.000
80 t - 3 Rollen	1000 kg								80.000	72.000	60.000	48.000	36.000	24.000	12.000
120 t- 5 Rollen	1100 kg				120.000	108.000	96.000	84.000	72.000	60.000	48.000	36.000	24.000	12.000	

Auslegerkonfiguration

Boom Configuration

Auslegerkonfiguration - Wippspitze SHWS (Hauptausleger SH mit wippbarem Spitzenausleger WS)
boom configuration - luffing jib SHWS (main boom SH and luffing jib WS)

Auslegerlänge [m] boom length [m]		Hauptausleger main boom					Spitzenausleger luffing jib						
		18,7	24,3	29,9	35,5	41,1	18,7	24,3	29,9	35,5	41,1	46,7	52,3
Fußstück SH Typ 1608 lower boom SH type 1608	7,0m	1	1	1	1	1							
Zwischenstück SH Typ 1608 boom insert SH type 1608	5,6m	1	2	1	2	1							
Zwischenstück SH Typ 1608 boom insert SH type 1608	11,2m	0	0	1	1	2							
Zwischenstück konisch SH Typ 1608/1370 tapered boom insert SH type 1608/1370	5,6m	1	1	1	1	1							
Rollenkopf T120 boom head T120	0,5m	1	1	1	1	1							
Spitzenauslegerfußstück LH Typ 1370 jib lower boom LH type 1370	7,0m						1	1	1	1	1	1	1
Zwischenstück LH Typ 1370 boom insert LH type 1370	5,6m						1	2	1	2	1	2	1
Zwischenstück LH Typ 1370 boom insert LH type 1370	11,2m						0	0	1	1	2	2	3
Zwischenstück konisch LH Typ 1370 tapered boom insert LH type 1370	5,6m						1	1	1	1	1	1	1
Rollenkopf T50 boom head T50	0,5m						1	1	1	1	1	1	1

Kombinationsmöglichkeiten possible configurations						
Länge Spitzenausleger [m] length luffing jib [m]	18,7	x	x	x	x	x
	24,3	x	x	x	x	x
	29,9	x	x	x	x	x
	35,5	x	x	x	x	x
	41,4	x	x	x	x	x
	46,7	x	x	x	x	x
	52,3	x	x	x	x	x

Auslegerkonfiguration - Feste Spitze SHLHFS (Hauptausleger SHLH mit fester Spitze FS)
boom configuration - fixed jib SHLHFS (main boom SHLH with fixed jib FS)

Auslegerlänge [m] boom length [m]		Hauptausleger main boom			Feste Spitze fixed jib			
		35,5	46,7	57,9	13,1	18,7	24,3	29,9
Fußstück SH Typ 1608 lower boom SH type 1608	7,0m	1	1	1				
Zwischenstück SH Typ 1608 boom insert SH type 1608	5,6m	2	1	2				
Zwischenstück SH Typ 1608 boom insert SH type 1608	11,2m		1	1				
Zwischenstück konisch SH Typ 1608/1370 tapered boom insert SH type 1608/1370	5,6m	1	1	1				
Zwischenstück LH Typ 1370 boom insert LH type 1370	5,6m	1	2	1				
Zwischenstück LH Typ 1370 boom insert LH type 1370	11,2m			1				
Zwischenstück konisch LH Typ 1370/610 tapered boom insert LH type 1370/610	5,6m	1	1	1				
Rollenkopf T50 boom head T50	0,5m	1	1	1				
Spitzenauslegerfußstück Typ 870 jib lower boom type 870	7,5m				1	1	1	1
Zwischenstück Typ 870 jib insert type 870	5,6m					1	2	3
Kopfstück typ 870 jib head type 870	5,6m				1	1	1	1

Kombinationsmöglichkeiten possible configurations				
Länge feste Spitze [m] length fixed jib [m]	13,1	x	x	x
	18,7	x	x	x
	24,3	x	x	x
	29,9	x	x	x

Selbstmontagesystem Self assembly system

1

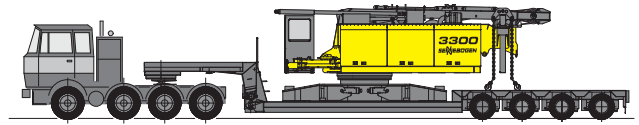

2

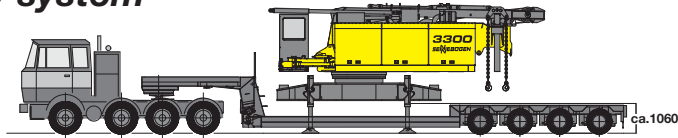

3

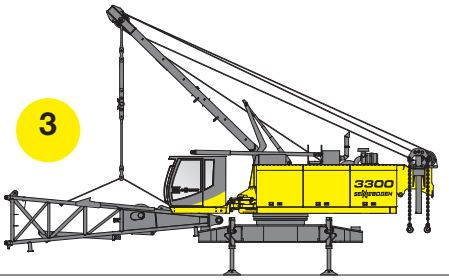

4

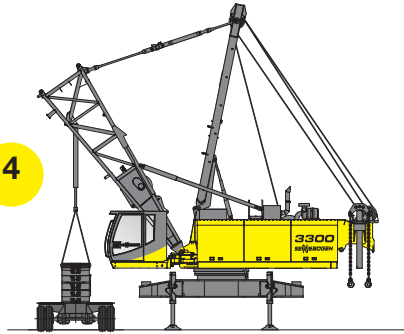

5

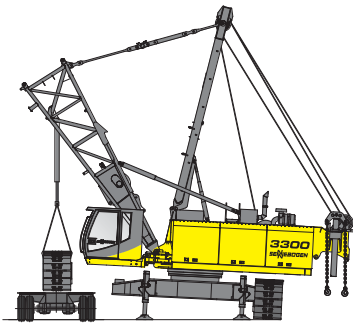

6

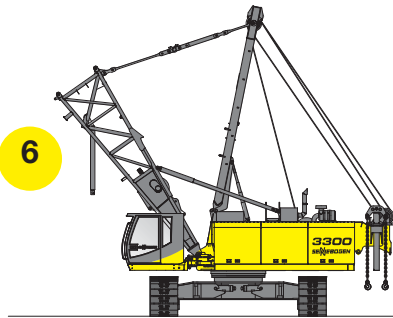

7

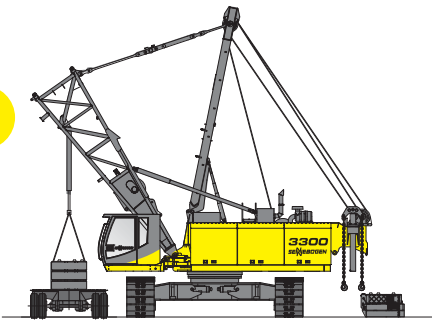

8

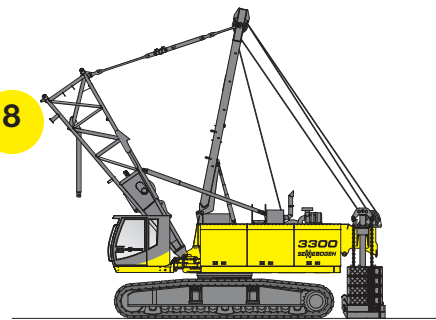

9

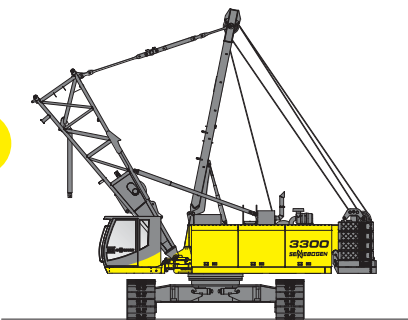

10

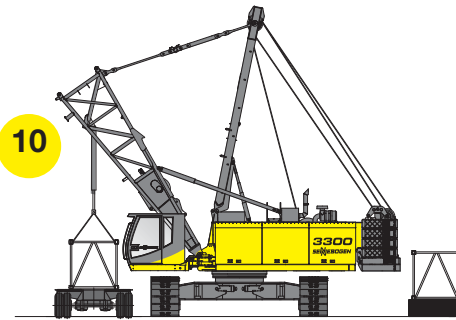

11

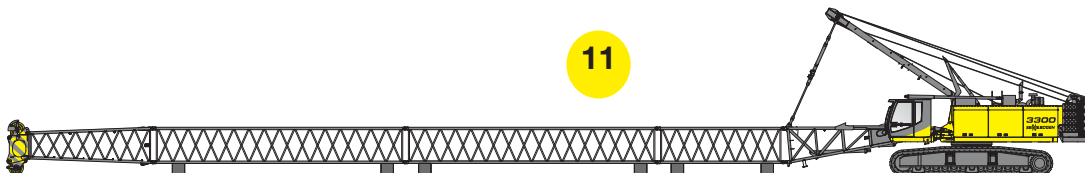

12

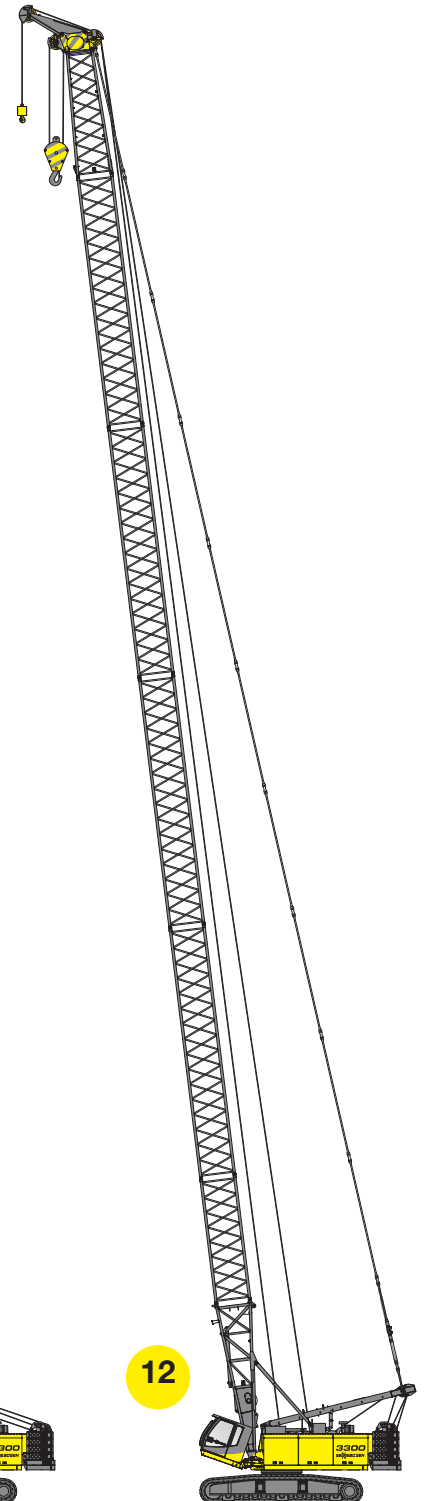

Aufrichten des Auslegers - SHWS

Booming up of - SHWS

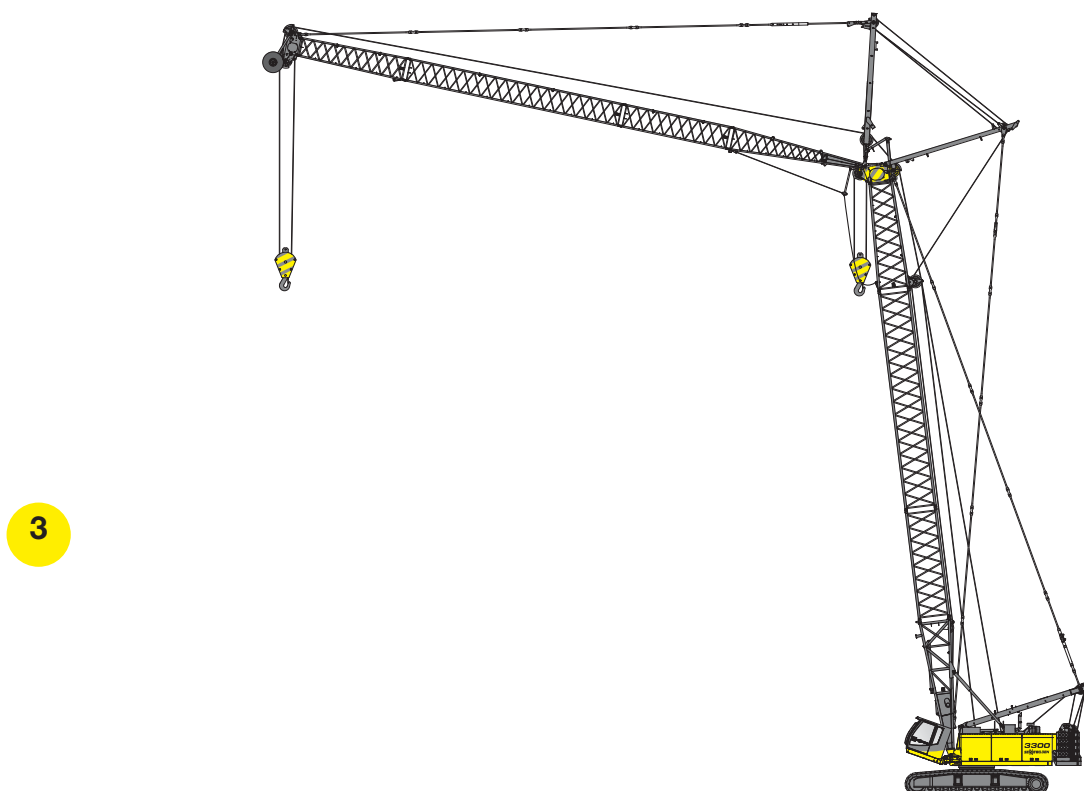
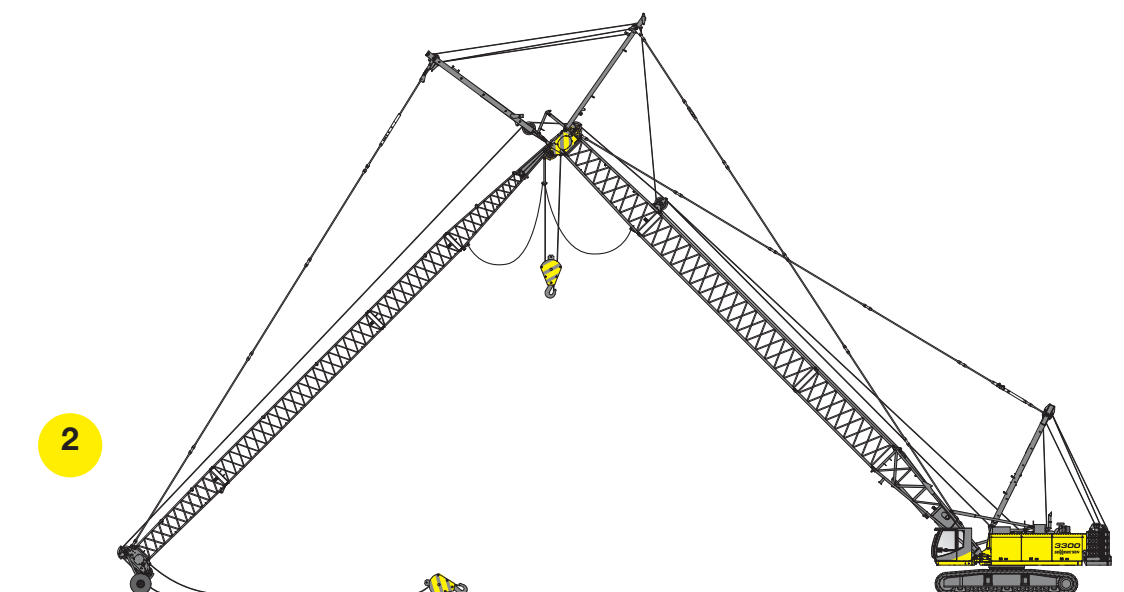
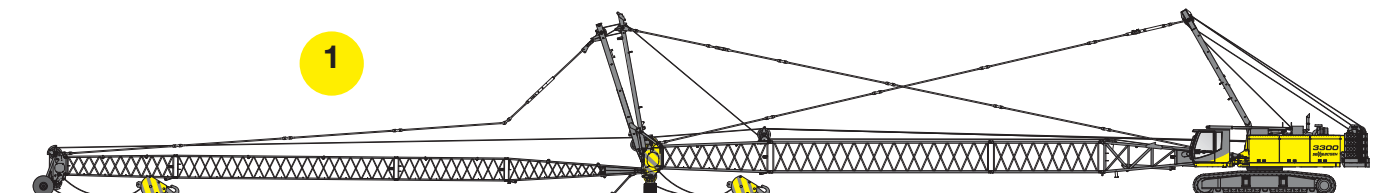

Transportabmessungen und Gewichte Transport dimensions and weights

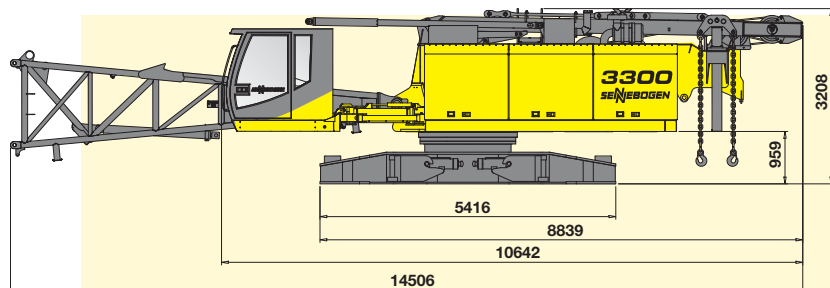

3300 Grundmaschine mit Fußstück
3300 basic machine with lower boom

Transportgewicht
Transport weight kg 39.500

Transportbreite/
transport width mm 3.200

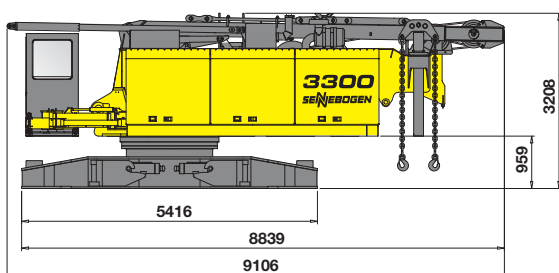

3300 Grundmaschine ohne Fußstück
3300 basic machine without lower boom

Transportgewicht kg 35.200

Transportbreite
transport width mm 3.000

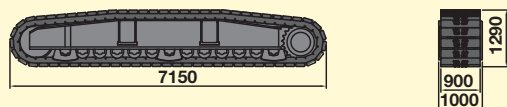

Raupenlaufwerk 2 Stück (B8b, 900 mm Flachbodenplatten)
Crawler 2 pieces (B8b, 900 mm flat shoes)

Gewicht / weight kg 13.000 (2x)

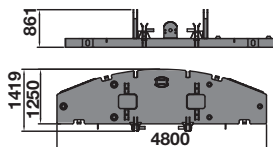

Ballastgrundplatte
Counterweight base plate

Gewicht / weight kg 7.600 (1x)

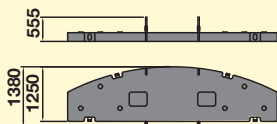

Ballastgrundplatte
Counterweight base plate

Gewicht / weight kg 7.600 (1x)



Gegengewicht 8 Stück
Counterweight 8 pieces

Gewicht / weight kg 2.800 (8x)

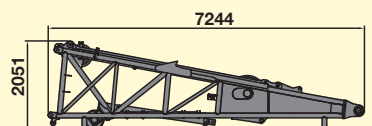

Auslegerfußstück 7 m Typ SH 1608 (inkl. Verstellwinde)
Lower boom 7 m type SH 1608 (incl. luffing winch)

Gewicht / weight kg 4.300
Breite / width mm 1.650

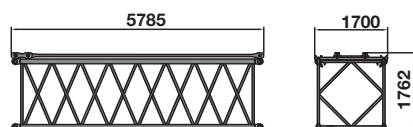

Auslegerzwischenstück 5,6 m Typ SH 1608 (mit SH/SHWS Abspannung)
Boom insert 5.6 m type SH 1608 (with SH/SHWS pendants)

Gewicht / weight kg 870/1000

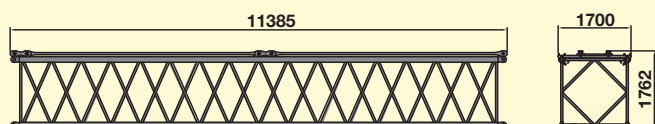

Auslegerzwischenstück 11,2 m Typ SH 1608 (mit SH/SHWS Abspannung)
Boom insert 11.2 m type SH 1608 (with SH/SHWS pendants)

Gewicht / weight kg 1560/1820

Transportabmessungen und Gewichte Transport dimensions and weights

SH

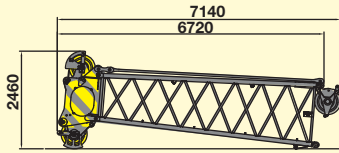

Auslegerkopfstück 5,6 m Typ SH 1608 mit SH/SHWS Abspannung und Auslegerkopf T120
Upper boom 5.6 m type SH 1608 with SH/SHWS pendants and boom head T120

Gewicht / weight	kg	2180/2490	(inkl. Rollenbock)
Breite / width	mm	1700	(incl. Roller Block)

LH

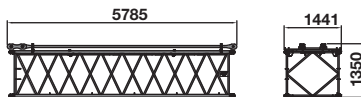

Ausleger - Zwischenstück 5,6 m Typ LH 1370 (mit Abspannung)
Boom insert 5.6 m type LH 1370 (with pendants)

Gewicht / weight	kg	520
------------------	----	-----

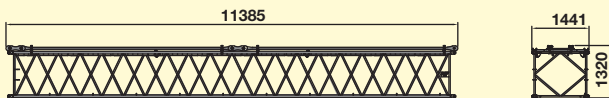

Ausleger - Zwischenstück 11,2 m Typ LH 1370 (mit Abspannung)
Boom insert 11.2 m type LH 1370 (with pendants)

Gewicht / weight	kg	970
------------------	----	-----

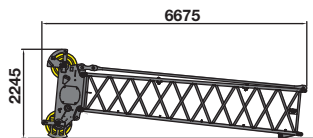

Auslegerkopfstück 5,6 m Typ LH 1370 mit Abspannung und Auslegerkopf T50
Upper boom 5.6 m type LH 1370 with pendants and boom head T50

Gewicht / weight	kg	1210
Breite / width	mm	1420

WS

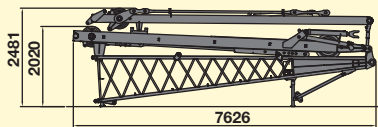

Auslegerfußstück WS 7 m Typ LH 1370 mit zwei Abspannböcken
Lower boom WS 7 m type LH 1370 with two A-frames

Gewicht / weight	kg	3750
Breite / width	mm	1750

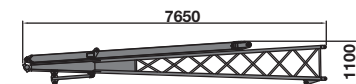

Auslegerfußstück Typ 870 (mit Abspannbock)
Lower boom type 870 (with A-frame)

Gewicht / weight	kg	900
Breite / width	mm	1150

FS

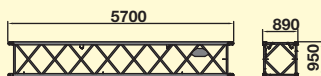

Auslegerzwischenstück 5,6 m Typ 870 (mit Seilen)
Boom insert 5.6 m type 876 (with ropes)

Gewicht / weight	kg	400
------------------	----	-----

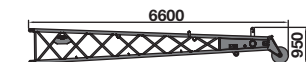

Auslegerkopfstück 5,6 m Typ 870 (mit Seilen)
Upper boom 5.6 m type 870 (with ropes)

Gewicht / weight	kg	500
Breite / width	mm	880

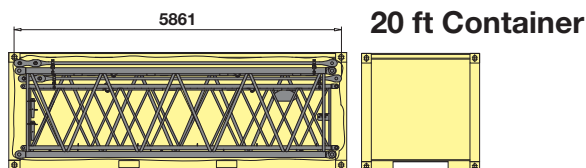

Auslegerzwischenstück 5,6 m Typ SH 1608 inkl. 5,6 m Typ LH 1370 mit SH/SHWS Abspannung
Boom insert 5.6 m type SH 1608 incl. 5.6 m type LH 1370 with SH/SHWS pendants

Gewicht / weight	kg	1390/1520
------------------	----	-----------

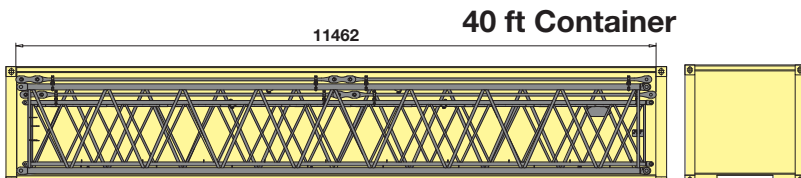

Auslegerzwischenstück 11,2 m Typ SH 1608 inkl. 11,2 m Typ LH 1370 mit SH/SHWS Abspannung
Boom insert 11.2 m type SH 1608 incl. 11.2 m type LH 1370 with SH/SHWS pendants

Gewicht / weight	kg	2530/2790
------------------	----	-----------

Grundmaschine
Basic Machine

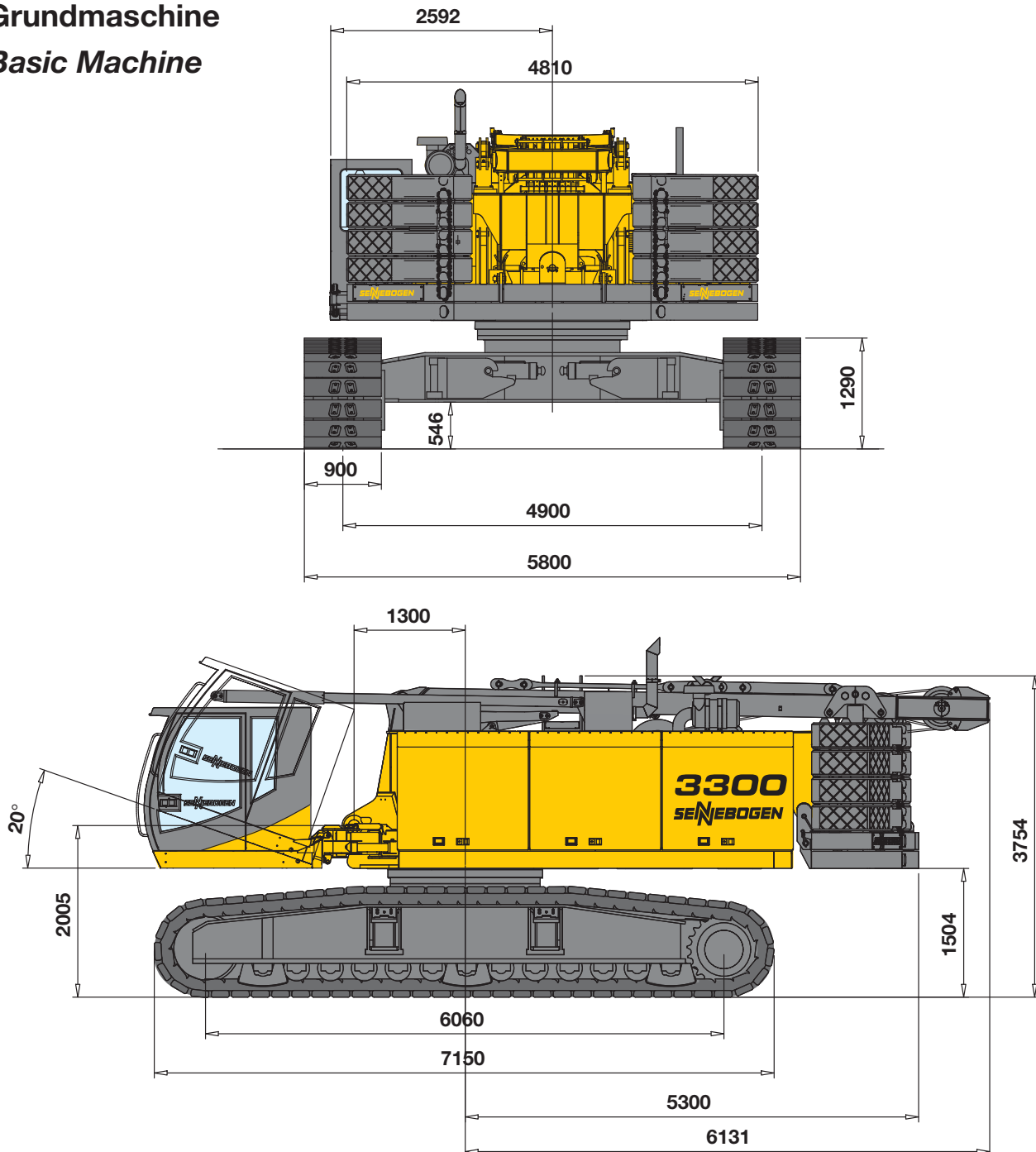

Vorsprung durch Innovation Leading through Innovation

SENNEBOGEN Maschinenfabrik GmbH
Hebbelstr. 30 · D-94315 Straubing

Tel: +49(0)9421/5 40-1 44/1 45 Fax: 540-340

E-mail: cranedivision@sennebogen.de www.sennebogen.de

Technische Änderungen ohne Vorankündigung und Verpflichtung gegenüber früher gelieferten Geräten vorbehalten! Die abgebildeten Geräte können Sonderausrüstungen haben! Irrtum und Druckfehler vorbehalten.

Technical specifications are subject to change without notice and without incurring responsibility for machines previously sold! The shown machines may have special equipment! Error and misprints reserved.

((())) www.sennebogen.de