

# Mining Excavator

# R 9800

Operating Weight with Backhoe Attachment:	800,000 kg / 1,763,698 lb
Operating Weight with Shovel Attachment:	810,000 kg / 1,785,742 lb
Engine Output:	2,984 kW / 4,000 hp
Bucket Capacity:	38.00 - 42.00 m <sup>3</sup> / 49.7 - 54.9 yd <sup>3</sup>
Shovel Capacity:	38.00 - 42.00 m <sup>3</sup> / 49.7 - 54.9 yd <sup>3</sup>



# LIEBHERR



# R 9800

Operating Weight with Backhoe Attachment: 800,000 kg / 1,763,698 lb

Operating Weight with Shovel Attachment: 810,000 kg / 1,785,742 lb

Engine Output: 2,984 kW / 4,000 hp

Bucket Capacity: 38.00 - 42.00 m<sup>3</sup> / 49.7 - 54.9 yd<sup>3</sup>

Shovel Capacity: 38.00 - 42.00 m<sup>3</sup> / 49.7 - 54.9 yd<sup>3</sup>











#### Liebherr Customized Buckets

- Capacity : 42 m<sup>3</sup> @ 1.8 t/m<sup>3</sup> / 3,000 lb/yd<sup>3</sup>
- Perfect match for trucks with 220 t payload and above
- Strong breakout and digging forces
- Integrated approach on machine capabilities, material properties and truck target payloads
- Customized and site-specific wear package configuration





# Performance by Design

More than 50 years of proven experience and innovation in designing and manufacturing hydraulic excavators, Liebherr has developed the optimal loading tool for large scale mining operations: the R 9800.

## High Productivity

Driven by two 1,492 kW/2,000 hp 16-cylinder V-engines, the Liebherr R 9800 boasts a 42 m<sup>3</sup> / 54.9 yd<sup>3</sup> bucket capacity. In conjunction with rapid loading cycles and tremendous digging and breakout forces, the R 9800 offers high loading capacity and is the perfect loader for 220-t, 290-t and 360-t mining trucks. The R 9800 represents the latest proven technologies available on the market.

## Reliability

Liebherr has consequently followed the design philosophy of improving the efficiency of all individual subsystems in order to maximize the efficiency and reliability of the overall machine, while in parallel reducing the operating cost. Its overall performance is based on Liebherr's robust hydraulic and auxiliary systems, delivering maximum uptime.

## Operating and Servicing

Liebherr's ultra large hydraulic excavator integrates the latest ergonomic and safety principles in order to create the best possible working environment for the operator and the service crews. The super silent mining cab with its large front windshield allows superior overview over the entire machine and loading spot. To reduce downtime, the R 9800's conception is focused on ergonomic, safe and comfortable serviceability, offering easy inspection access and short maintenance times. All service fluids can easy and quickly be exchanged or refilled through the service flap. With extended service intervals of up to 1.000 SMU, Liebherr's R 9800 is the basis for maximum production hours.

## Safety and Environment

Railings and catwalks help to easily access all relevant machine areas. The 45° access stair helps entering the machine comfortably. In case of emergency stops the stair is automatically activated. Liebherr's fully integrated optional electrical drive system allows for high operating efficiency and additional power. Due to the long service intervals of electrical machines uptime can be enhanced while maintenance costs are decreased. The silent electrical drive contributes to health, safety and environmental care.



### Engine / Motor Options

- Two Cummins QSK 60 (2,984 kW / 4,000 hp @1800 rpm)
- Two MTU 12V4000 (2,850 kW / 3,820 hp @1800 rpm)
- USA/EPA Tier 2 and Tier 4i compliant (optional: fuel consumption-optimized setting)
- Two electrical motors (option) (3,400 kW / 4,559 hp)



### High Machine Efficiency

- Oversized cooling system for low fan power consumption
- Increased pipe and hose diameters for improved hydraulic efficiency
- Electronic and optimized attachment control for faster combined movements and optimized cycle time
- Backhoe and Shovel attachment designed to achieve ideal force distribution over the digging area and high production rates
- Electronic engine power and idle management

# Technical Data



## Engine

2 Cummins diesel engine	
Rating per SAE J 1995	2 x 1,492 kW/2 x 2,000 hp at 1,800 rpm
Model	QSK60 (USA/EPA Tier 2 and Tier 4i compliant)
Type	16 cylinder V-engine
Displacement	60 l/3,661 in <sup>3</sup>
Bore/Stroke	159/190 mm/6.26/7.48 in or
2 MTU diesel engine	
Rating per ISO 3046	2 x 1,425 kW/2 x 1,910 hp at 1,800 rpm
Model	12V4000 (USA/EPA Tier 2 and Tier 4i compliant)
Type	12 cylinder V-engine
Displacement	57.2 l/3,490 in <sup>3</sup>
Bore/Stroke	170/210 mm/6.69/8.26 in
Engine cooling system	fans driven via hydraulic piston motors
Air cleaner	dry-type air cleaner with pre-cleaner, automatic dust ejector, primary and safety elements
Fuel tank	19,690 l/5,202 gal
Fuel filtration	2 stage fuel filtration with water separator and electric priming pump
Engine lubrication	pre-lube starting system ELIMINATOR™ engine oil automatic filtration system (Cummins) + centrifugal filtration engine oil automatic filtration system (MTU) + centrifugal filtration
Electrical system	
Voltage	24 V
Batteries	8 x 170 Ah/12 V starting batterie 4 x 170 Ah/12 V service systems
Alternator	2 x 24 V/260 Amp (brushless)
Engine idling	electronically controlled
Electronic engine power management	engine power and speed sensing over the entire engine rpm range



## Hydraulic System

Attachment and travel drive	
Hydraulic pumps	10 variable flow axial piston pumps
Max. flow	10 x 750 l/min./10 x 198 gpm
Max. hydr. pressure	320 bar/4,641 psi
Swing drive	
Hydraulic pumps	4 reversible swash plate pumps, closed-loop circuit
Max. flow	4 x 535 l/min./4 x 141 gpm
Max. hydr. pressure	350 bar/5,076 psi
Pump management	electronically controlled pressure and flow management with oil flow optimisation
Hydraulic tank capacity	5,800 l/1,532 gal
Hydraulic system capacity	10,000 l/2,642 gal
Hydraulic oil filter	1 high pressure safety filter after each high pressure pump + fine filtration of entire return flow
Hydraulic oil cooler	4 separate coolers, 4 temperature controlled fans driven via hydraulic piston motors
Main pump protection	automatic protection against low oil level



## Hydraulic Controls

Servo circuit	independant, electronic over hydraulic proportional controls of each function
Emergency control	emergency lowering of the attachment to the ground
Power distribution	via monoblock control valves with integrated primary relief valves and flanged on secondary valves for travel and with integrated proportional and safety valves
Flow summation	to attachment and travel drive
Electro-hydraulic servo control	
Attachment and swing	electronic optimized control via proportional valves
Travel	electronic optimized control via proportional valves
Electronic damping system	Liebherr designed electronic control of cylinder end-position



## Electric System

Electric isolation	easy accessible battery isolations
Working lights	Xenon lights: - 4 on working attachment - 2 on RHS of uppercarriage - 2 on LHS of uppercarriage - 2 on counterweight
Emergency stop switches	at ground level, in hydraulic compartment, in engine compartment and in operator cab
Electrical wiring	heavy duty execution in IP 65 standard for operating conditions of - 50 °C to 100 °C/ - 58 °F to 212 °F



## Swing Drive

Hydraulic motor	4 Liebherr axial piston motors
Swing gear	4 Liebherr planetary reduction gears
Swing ring	Liebherr, sealed triple roller swing ring, internal teeth
Swing speed	0 - 3.6 rpm
Swing-holding brake	4 hydraulically released, maintenance-free, external multi-disc brakes



## Uppercarriage

Design	torsion resistant designed upper frame in box type structure for superior strength and durability
Attachment mounting	parallel longitudinal main girders in box-section structure
Machine access	45° access system with handrails on the cab side of the uppercarriage. Full controlled descent in case of emergency stop. Additional emergency ladder fitted near the cab

# Technical Data



## Operator's Cab

Design	resiliently mounted, sound insulated, large windows for all-around visibility, integrated falling object protection FOPS
Operator's seat	suspended pneumatic seat, body-contoured with shock absorber, adjustable to operator's weight, additional "retractable passenger/trainer seat" seat heating
Cabin windows	20.5 mm/0.8 in tinted armored glass for front window and 15 mm/0.6 in for right hand side windows, all other windows in tinted safety glass, high pressure windshieldwasher-system with 75 l/20 gal watertank, sun louvers on all windows in heavy duty design
Heating system/ Air conditioning	heavy duty, fully automatic, high output air conditioner and heater unit
Cabin pressurization	ventilation unit with filters
Controls	joystick levers integrated into armrest of seat, armrest adjustable to seat position
Display	10.5 in color LCD-Display with low and high brightness settings
Condition monitoring	machine condition monitoring system with error reporting and operational information
Rear vision systems	camera installation on counterweight and right-hand side of the uppercarriage displayed over an additional LCD-Display
Safety function Automatic engine shut off	engine self controlled power limitation and shut off
Safety functions	additional gauges with constant display for: engine speed, hourmeter, voltmeter, safety mode for engine speed control and pump regulation



## Undercarriage

Design	3-piece undercarriage, box type structure for center piece and side frames, stress relieved
Hydraulic motor	3 axial piston motors per side frame
Travel gear	Liebherr planetary reduction gear
Travel speed	0 – 2.0 km/h, optional 0 – 2.5 km/h/ 1.2 mph/1.6 mph
Parking brake	spring engaged, hydraulically pressure released external wet multi-disc brakes for each travel motor, maintenance-free
Track components	maintenance-free dual pin cast link and pad combined
Track rollers/ Carrier rollers	6/3
Automatic track tensioner	pressurized hydraulic cylinder with accumulator, maintenance free
Transport	undercarriage side frames are removable



## Service Flap

Design	hydraulically actuated service flap, easily accessible from ground level to including: <ul style="list-style-type: none"> <li>– 2 fast fuel refill lines</li> <li>– hydraulic oil refill and drainage</li> <li>– engine oil exchange</li> <li>– splitterbox oil exchange</li> <li>– swing gearbox oil exchange (4 x draining / 4 x refill)</li> <li>– swing ring teeth grease barrel refilling with grease filter</li> <li>– attachment/swing ring bearing grease barrel refilling with grease filter</li> <li>– windshield washer water refilling</li> <li>– oil reserve system refilling (optional)</li> <li>– different couplings available on request</li> </ul>
--------	--



## Central Lubrication System

Type	Lincoln Centromatic lubrication system for the entire attachment/swing ring bearing and teeth
Grease pumps	1 Lincoln Powermaster pump for attachment/swing ring bearing lubrication (second pump with switch over function in option) 1 Lincoln Flowmaster pump for swing ring teeth lubrication
Capacity	600 l/158.5 gal bulk container for attachment/swing ring bearing, separated 80 l/ 21 gal container for swing ring teeth
Refill	via the service flap for both containers with grease filters



## Attachment

Design	box-type structure with large steel castings in all high-stress areas
Stick	wear protection underneath lower beam plate
Pivots	two floating pins per pivot, sealed covers, all bearings with wear resistant steel bushings, bolts hardened and chromium-plated
Hydraulic cylinder	Liebherr design, electronically controlled end-cushioning
Hydraulic connections	pipes and hoses equipped with SAE connections
Pivots bucket-to-stick/ bucket-to-link	O-ring sealed and completely enclosed
Lubrication	connected to the centralized lubrication system, each lubrication point independently lubricated

# Dimensions

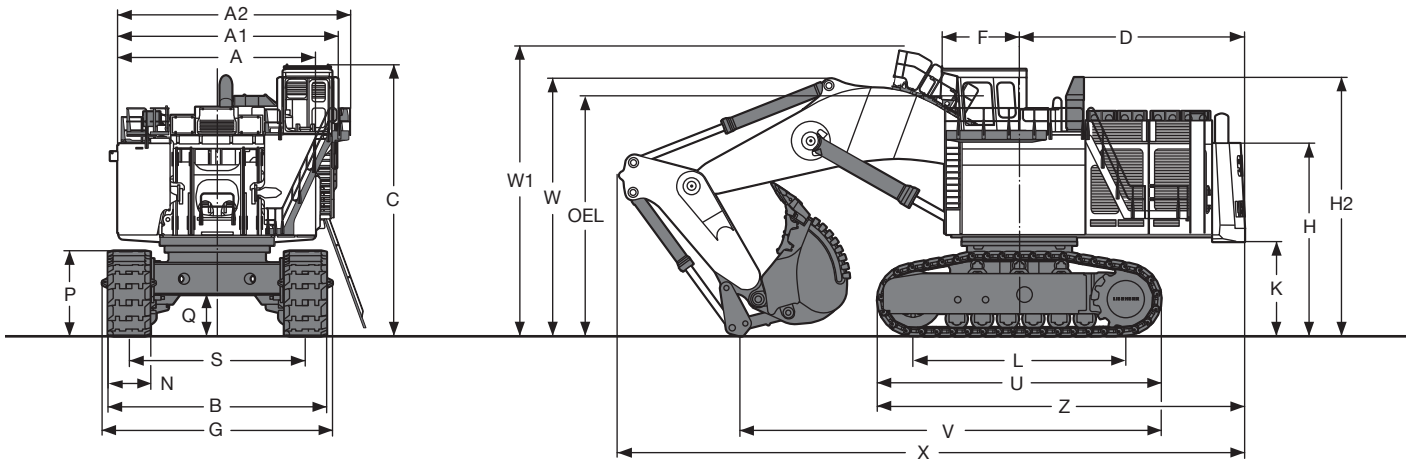

	mm/ft in
A	7,550/24' 9"
A1	8,408/27' 6"
A2	8,880/29' 1"
C	10,338/33' 10"
D	8,600/28' 2"
F	2,955/ 9' 8"
H	7,347/24' 1"
H2	9,638/31' 7"
K	3,597/11' 9"
L	8,098/26' 6"
P	3,261/10' 8"
Q	1,574/ 5' 1"

	mm/ft in
S	6,700/21' 11"
U	10,846/35' 6"
Z	14,023/45' 11"
N	1,630/ 5' 4"
B	8,330/27' 3"
G	8,778/28' 9"
V	16,055/52' 7"
W	9,834/32' 3"
W1	11,063/36' 3"
X	23,907/78' 4"
OEL	Operator's Eye Level
	8,800/28' 10"



# Dimensions

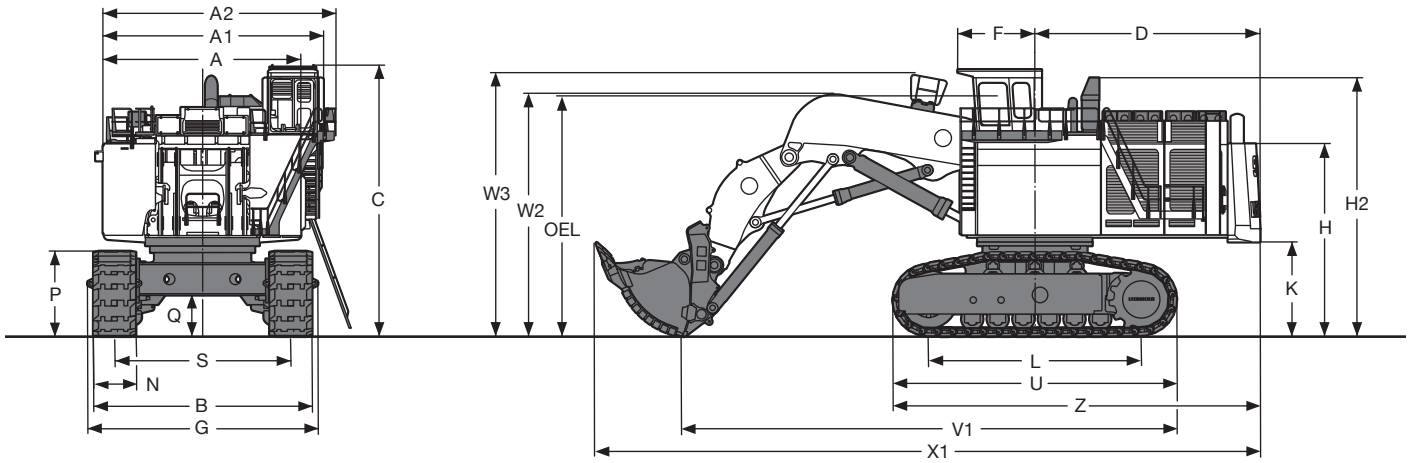

	mm/ft in
A	7,550/24' 9"
A1	8,408/27' 6"
A2	8,800/28' 10"
C	10,338/33' 10"
D	8,600/28' 2"
F	2,955/ 9' 8"
H	7,347/24' 1"
H2	9,638/31' 7"
K	3,597/11' 9"
L	8,098/26' 6"
P	3,261/10' 8"
Q	1,574/ 5' 1"

	mm/ft in
S	6,700/21' 11"
U	10,846/35' 6"
Z	14,023/45' 11"
N	1,630/ 5' 4"
B	8,330/27' 3"
G	8,778/28' 9"
V1	18,850/61' 9"
W2	9,280/30' 5"
W3	10,050/32' 11"
X1	25,330/83'
OEL	Operator's Eye Level 8,800/28' 10"

# Backhoe Attachment

with Gooseneck Boom 11.75 m/38'6"

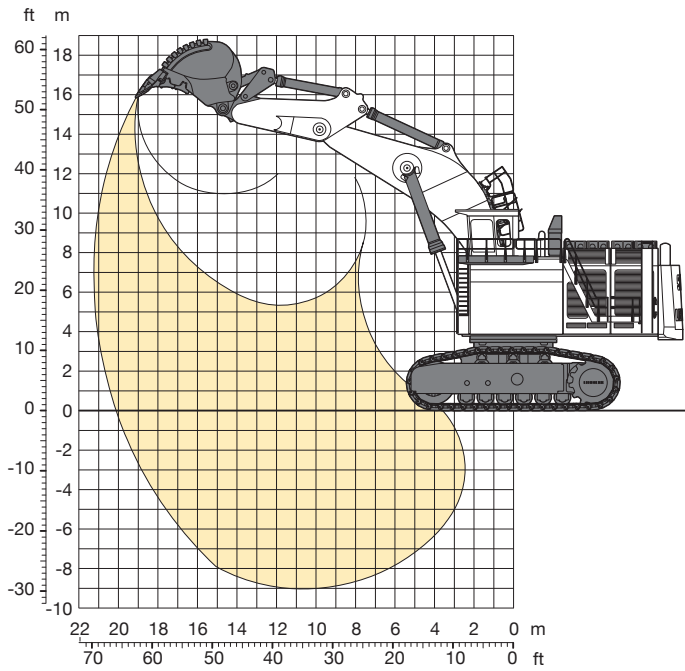

## Digging Envelope

Stick length	5.00 m/16' 4"
Max. reach at ground level	20.10 m/65' 11"
Max. teeth height	16.20 m/53' 1"
Max. dump height	10.90 m/35' 9"
Max. digging depth	9.00 m/29' 6"
Max. digging force	1760 kN/395,664 lbf
Max. breakout force	1920 kN/431,633 lbf

## Operating Weight and Ground Pressure

The operating weight includes the basic machine with backhoe attachment and a 42.00 m<sup>3</sup>/54.9 yd<sup>3</sup> bucket.

Pad width	mm/ft in	1,630/5'4"
Weight	kg/lb	800,000/1,763,696
Ground pressure	kg/cm <sup>2</sup> /psi	2.71/38.55

## Buckets

For materials classe according to VOB, Section C, DIN 18300		5 – 6	5 – 6	5 – 6	7 – 8
Typical operation according to VOB, Section C, DIN 18300		HD	HD	HD	XHD
Capacity ISO 7451	m <sup>3</sup>	38.00	40.00	42.00	38.00
	yd <sup>3</sup>	49.70	52.32	54.94	49.70
Suitable for material up to a specific weight of	t/m <sup>3</sup>	2.0	1.9	1.8	1.9
	lb/yd <sup>3</sup>	3,373	3,204	3,035	3,204
Cutting width	mm	4,800	4,800	4,800	4,800
	ft in	15'8"	15'8"	15'8"	15'8"
Weight	kg	43,000	43,600	45,150	47,000
	lb	94,799	96,121	99,539	10,3617

HD: Heavy-duty bucket with Esco S145 teeth

XHD: Heavy-duty rock bucket with Esco S145 teeth



# Shovel Attachment

with Shovel Boom 8.55 m/28'

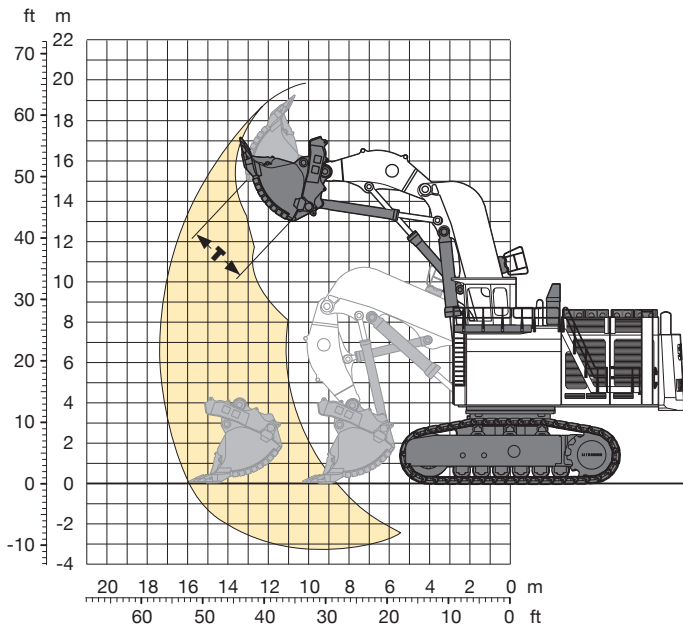

## Digging Envelope

Stick length	5.10 m/16' 8"
Max. reach at ground level	15.90 m/52' 1"
Max. dump height	13.00 m/42' 7"
Max. crowd length	5.60 m/18' 4"
Bucket opening width T	3.00 m/ 9'10"
Crowd force at ground level	2950 kN/663,186 lbf
Max. crowd force	3050 kN/685,667 lbf
Max. breakout force	2400 kN/539,541 lbf

## Operating Weight and Ground Pressure

The operating weight includes the basic machine with shovel attachment and a 42,00 m<sup>3</sup>/54.9 yd<sup>3</sup> bucket.

Pad width	mm/ft in	1,630/5'4"
Weight	kg/lb	810,000/1,785,742
Ground pressure	kg/cm <sup>2</sup> /psi	2.746/39.06

## Bottom Dump Buckets

For materials classe according to VOB, Section C, DIN 18300		5 – 6	5 – 6	5 – 6	7 – 8
Typical operation according to VOB, Section C, DIN 18300		HD	HD	HD	XHD
Capacity ISO 7546	m <sup>3</sup>	38.00	40.00	42.00	38.00
	yd <sup>3</sup>	49.70	52.32	54.94	49.70
Suitable for material up to a specific weight of	t/m <sup>3</sup>	2.0	1.9	1.8	1.9
	lb/yd <sup>3</sup>	3,373	3,204	3,035	3,204
Cutting width	mm	5,600	5,600	5,600	5,600
	ft in	18'4"	18'4"	18'4"	18'4"
Weight	kg	75,000	75,300	75,500	79,000
	lb	165,347	166,008	166,449	174,165
Wear kit level		II	II	II	III

HD: Heavy-duty bucket with Esco S145 teeth

XHD: Heavy-duty rock bucket with Esco S145 teeth

Level II: For preblasted heavy rock, or deteriorated, cracked material (classification 5 to 6, according to DIN 18300)

Level III: For highly-abrasive materials such as rock with a high silica content, sandstone etc.

# The Liebherr Group of Companies

## Wide product range

The Liebherr Group is one of the largest construction equipment manufacturers in the world. Liebherr's high-value products and services enjoy a high reputation in many other fields, too. The wide range includes domestic appliances, aerospace and transportation systems, machine tools and maritime cranes.

## Exceptional customer benefit

Every product line provides a complete range of models in many different versions. With both their technical excellence and acknowledged quality, Liebherr products offer a maximum of customer benefits in practical application.

## State-of-the-art technology

To provide consistent, top quality products, Liebherr attaches great importance to each product area, its components and core technologies. Important modules and components are developed and manufactured in-house, for instance the entire drive and control technology for construction equipment.

## Worldwide and independent

Hans Liebherr founded the Liebherr family company in 1949. Since that time, the enterprise has steadily grown to a group of more than 100 companies with over 32,000 employees located on all continents. The corporate headquarters of the Group is Liebherr-International AG in Bulle, Switzerland. The Liebherr family is the sole owner of the company.

[www.liebherr.com](http://www.liebherr.com)



Printed in Germany by Eberl RG-BK-RP LFR/SP 11003241-2-03.10\_enGB-US

## Liebherr-France SAS Mining Division

49 rue Frédéric Hartmann, CS 50038, F-68025 Colmar Cedex

☎ +33 369 4921 99, Fax +33 369 4922 79

[www.liebherr.com](http://www.liebherr.com), E-Mail: [info.lfr-mining@liebherr.com](mailto:info.lfr-mining@liebherr.com)