

Crawler Tractors

PR 754
Litronic®

PR 764
Litronic®

Engine output: 250 kW / 340 HP
Operating weight: 35,000 / 40,800 kg
77,162 / 89,948 lb

310 kW / 422 HP
44,220 / 52,685 kg
97,488 / 116,150 lb



LIEBHERR

PR 754

Litronic

Engine output: 250 kW / 340 HP
Service weight: 35,000 – 40,800 kg
77,162 – 89,948 lb
Blade capacity: 8.9 – 11.7 m³
11.6 – 15.3 yd³

Hydrostatic travel drive,
electronically controlled

PR 764

Litronic

Engine output: 310 kW / 422 HP
Service weight: 44,220 – 52,685 kg
97,488 – 116,150 lb
Blade capacity: 13.6 – 17.0 m³
17.8 – 22.2 yd³

Hydrostatic travel drive,
electronically controlled



Performance

Power and innovative technology are features of Liebherr's generation 4 crawler tractors. Their excellent power-to-weight ratio stands for maximum productivity in all operating conditions. Whether ripping hard ground, moving material or grading surfaces, the outstanding performance of the PR 754 and PR 764 never fails to impress.

Economy

Liebherr's economic advantages are undisputed: like all Liebherr machines, the PR 754 and PR 764 save money by being so easy to service, with shorter down times and lower maintenance costs. The latest generation of Liebherr diesel engines combines performance with economy, and with the machines' efficient drivetrain, impressive power is available at minimum fuel consumption.

Reliability

Sturdy and strong: Liebherr crawler tractors and the materials used to build them are designed for long, trouble-free life. Components subject to severe loads are made from high-strength materials, and points exposed to possible damage are well protected. Liebherr crawler tractors owe their high levels of availability to these stringent reliability standards.

Comfort

The operator of a generation 4 Liebherr crawler tractor works in a cab of generous size, with controls laid out according to the latest ergonomic principles. This well-designed cab provides an ideal view of the work area and the working equipment. Intuitive single-lever control makes for sensitive and accurate dozer operation.





Liebherr diesel engines featuring the latest technologies:

- Electronically controlled, the power output and torque curves are designed for outstanding productivity when pushing or ripping.
- Environmentally responsible and economical: the engines comply with the latest exhaust emission limits.
- An extra-deep oil sump maintains engine lubrication at slopes of up to 45 degrees.



Performance

Liebherr has successfully been building crawler tractors with hydrostatic transmission for the past thirty years. The latest generation 4 of models are powerful machines capable of tackling a wide range of tasks.

Outstanding productivity

Impressive power and drawbar pull

The powerful Liebherr diesel engine, combined with Liebherr's innovative driveline, makes ample power available for every working situation. The hydrostatic drive requires no gear shifting: engine power reaches the tracks without interruption, even when turning.

Efficient pushing and ripping

Thanks to the hydrostatic transmission, the operator simply selects the most suitable working speed. The system automatically maintains peak engine rpm and power efficiency. Track slip is kept low and maximum power is continuously transferred to the tracks.

Bogie suspension

For work on uneven or rough surfaces, Liebherr offers different types of bogie undercarriages for increased traction and pushing power.

Outstanding maneuverability

The hydrostatic drive is particularly suitable for ripping work. The machine can be turned quickly, the rear ripper positioned accurately between hard rock layers, and the material broken out with the necessary force.

Blade curvature for top transport capacity

The blades for the PR 754 and PR 764 have had their penetration and rolling behaviour optimized, to increase their transport capacity.

Low center of gravity

The driveline assemblies are compact so that the complete machine has a very low center of gravity, thereby allowing safe operation on steep slopes.

Generous ground clearance

The well-planned component layout is designed for maximum ground clearance. Heavy duty belly pans prevent damage when working on rough stone or rock.

Liebherr hydrostatic transmission

- Automatic speed and torque adjustment keeps the engine working at optimal power as the load changes.
- At low ground speeds, for instance during ripping work, the thermal loads on the hydrostatic travel gear are kept low. The driveline's high efficiency remains available in all speed ranges.



Oscillating roller tracks

- When working on uneven surfaces, oscillating bogie undercarriages increase the ground contact area and improve traction. In addition, the resilient mountings effectively absorb shock loads.
- For work on softer, more yielding surfaces such as coal or wood chips, tracks with rigid rollers are used.

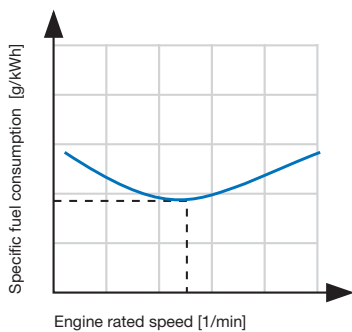

**Constant engine speed
keeps fuel consumption low**

- Since the engine's nominal operating speed is in the region of its lowest specific fuel consumption, maximum operating economy is assured.



Economy

Liebherr crawler tractors are designed with economy in mind, featuring low fuel consumption, high productivity, extended component life and minimum maintenance costs.

Low fuel consumption

Constant low engine speeds

The Liebherr diesel engine always operates at a constant speed – in the most economical rpm range – regardless of the actual travel speed. This avoids unnecessary fuel consumption.

A low mean piston speed boosts cylinder filling and leads to more efficient combustion of the fuel-air mixture.

Efficient driveline

Hydrostatic transmission delivers the best possible level of efficiency over the full speed range. Even when peak power at low ground speed is required - e.g. when ripping - the oil temperature remains low.

Load-sensing implement hydraulics

This system keeps energy consumption down to the level needed by the hydraulics at any given moment. It saves fuel when the work tools are not being operated.

Low maintenance costs

Good accessibility

All the diesel engine's servicing points are grouped together centrally, and can be easily reached. The hydraulic tilt cab makes it even easier to reach the various mechanical assemblies for quick, effective servicing.

Longer maintenance intervals

Maintenance intervals are optimally matched to the various components and assemblies. Where parts are exposed to dirt and dust, for instance on the pushing frame, maintenance-free bearings are used.

Long-life tracks

Large track components

High-quality components with ample dimensions prolong the operating life of the undercarriage.

Tilttable cab

- For easy, quick access to all drivetrain and hydraulic components.

Simple maintenance

- All the servicing points are located centrally and are easy to reach, to minimize the time spent on daily inspection work.



Liebherr Litronic control system

- Liebherr's Litronic control system matches travel speed ideally to the task at hand.
- Track slip is kept to a minimum in pushing as well as in ripping applications; this improves power transmission and prolongs track life.



The ideal configuration for every task

- There is a mining version for use on abrasive materials. Optional wear plates increase machine operating life before components have to be replaced.
- Liebherr offers special machine configurations for landfill, coal, or woodchip applications, as well as for low ambient temperatures.



Reliability

Well-proven technologies and high quality are what keeps a machine ready for use. Liebherr develops and builds its own components and assemblies specifically for use on construction and civil engineering machinery, so that their strength can be guaranteed however arduous the task.

Liebherr powertrain

Reliable construction-machinery engines

Liebherr diesel engines have been developed for the toughest imaginable operating conditions. A rigid ladder-type frame reduces engine vibration and provides the strength needed for maximum operating reliability and long service life.

Wear-free driveline concept

A tried and tested system: Liebherr's hydrostatic travel drive needs no torque converter, manual-shift gearbox, differential steering or steering clutches. The system's hydraulic pumps and motors are standardised, effectively wear-free in operation and exceptionally reliable.

Long-life final drives

Of ample dimensions, Generation 4 final drives are designed to withstand the most severe loads. Double transmission seals with automatic leak detection enhance reliability even more.

Robust steel construction

Box-section main frame

The main frame is of box-section design – a well-proven principle for maximum torsional stiffness and optimal absorption of forces. Cast steel is used for components subject to high stress.

Rear ripper

Liebherr rippers are built for heavy-duty tasks, and have extra protection at all areas exposed to wear.

Secrets of long-term reliability

Modern cooling system

Two hydrostatically driven fans and a wide-meshed radiator guarantee optimal cooling performance, even in dusty environments.

Protected electrics

High quality cable protection prevents mechanical damage to the cable harness.

Component endurance tests

- Even at the design stage, components are subjected to FE analysis in order to determine their dimensions in relation to the loads they will encounter.
- All components undergo long-term laboratory and field testing, and only those that comply with Liebherr's high quality standards are approved for production.



Modern cooling system

- Two electronically controlled fans draw in the volume of air actually needed to keep the hydraulic fluid and engine oil temperatures stable as loads vary. All components operate in their most favourable temperature ranges, thus avoiding unnecessary strain and prolonging their trouble-free operating life.
- Cooling air is drawn in from clean zones around the machine, to keep dust contamination to a minimum.
- Optional: a reversible fan for automatic radiator cleaning when operating in extremely dirty or dusty conditions.



Intuitive single-lever control

- Fingertip speed control: three travel speed ranges can be preselected and programmed individually by push-button:
Initial settings Stage 1: 0 – 2.5 mph
 Stage 2: 0 – 4.0 mph
 Stage 3: 0 – 6.8 mph
- Memory function
Each time the machine is restarted, all existing settings are retained.



Inching brake pedal

- In addition to the travel joystick, the operator can control speed via a pedal and apply the brakes if necessary.
- 1 Inching function
2 Braking function

Comfort

The operator's work area has been redesigned for an exceptionally high level of comfort and convenience. There is ample space, the controls are laid out ergonomically and the noise level is low. Liebherr cabs provide perfect conditions for concentrated work without fatigue. The excellent view makes safe, accurate operation much easier.

Outstanding cab design

Ergonomics

The well-planned cab layout makes conditions ideal for stress-free, efficient operation of the machine. All instruments and controls are clearly laid out and within easy reach.

Low noise levels

Thanks to effective sound insulation and the use of modern, quiet-running diesel engines, the PR 754 and PR 764 feature exemplary noise levels that are well below the legal limits.

Outstanding view

Integral ROPS/FOPS protection and large-area cab windows provide the operator with the best possible view in every direction.

Simple, precise control

Single-lever control

A single lever controls all travel movements conveniently and accurately, including the 'counter rotation' function.

Stepless speed control

Ground speed can be selected without gear changes and therefore with no interruption to the transmission of power.

Safety in every situation

Even on steep gradients, the crawler tractor is always positively driven. Since the system cannot freewheel (hydrostatic transmission), the operator controls braking simply by moving back the travel joystick. When the machine comes to a halt, the parking brake is applied automatically for additional safety.



Well-planned details

- A big storage compartment is a standard feature, and includes a 12 Volt power socket to supply a cooler.
- The seat with its wide range of adjustments and three-position armrests helps to provide a pleasant work area for the operator.
- Many other details, for example a sliding side window, tinted glass and a footrest, add to the operator's comfort still further.



Excellent view of rear-end attachments

- ROPS/FOPS protection is integrated into the cab, with large-area windows
- Good view of ripper and surrounding work area
- Direct view of ripper adjusting pin

Basic machine



Engine

	PR 754	PR 764
Liebherr diesel engine	D 946 L A6 Emission regulations according to 97/68/EC, 2004/26/EC Stage IIIA and EPA/CARB Tier 3	D 9508 A7
Rating (ISO 9249)	250 kW / 340 HP	310 kW / 422 HP
Rating (SAE J1349)	250 kW / 335 HP	310 kW / 416 HP
Rated speed	1,600 1/min	1,600 1/min
Displacement	12 l / 733 in ³	16.2 l / 989 in ³
Design	6 cylinder in-line-engine	8 cylinder V-engine (wet-sleeve) water-cooled, turbocharged, intercooled
Injection system	Direct fuel injection, pump-line-nozzle system, electronic control	Direct fuel injection, Common Rail system, electronic control
Lubrication	Force-feed lubrication, engine lubrication guaranteed for inclinations up to 45°	
Operating voltage	24 V	24 V
Alternator	80 A	80 A
Starter	7.8 kW / 11 HP	7.8 kW / 11 HP
Batteries	2 x 225 Ah / 12 V	2 x 225 Ah / 12 V
Air cleaner	Dry-type air cleaner with safety element, aspirated pre-cleaner, service gauge in cab	
Cooling system	Combi radiator, comprising a radiator for water and charge air. Hydrostatic fan drive	



Travel drive, control

	PR 754	PR 764
Transmission system	Infinitely variable hydrostatic travel drive, independent drive for each track	
Travel speed*	continuously variable	
Speed range 1 (reverse)	0– 4.0 km/h / 2.5 mph (4.8 km/h / 2.9 mph)	
Speed range 2 (reverse)	0– 6.5 km/h / 4.0 mph (7.8 km/h / 4.8 mph)	
Speed range 3 (reverse)	0–11.0 km/h / 6.8 mph (11.0 km/h / 6.8 mph)	
	* Pre-adjusted, all speed ranges can be customised on the travel joystick (memory function)	
Drawbar pull at 1.5 km/h / 0.9 mph	520 kN	610 kN
Electronic control	Electronic engine speed sensing control (load sensing feature) automatically adjusts travel speed and drawbar pull to match changing load conditions	
Steering	Hydrostatic	
Service brake	Wear-free, hydrostatic (dynamic braking)	
Automatic park brake	Wear-free, wet multiple-disc brakes, automatically applied with neutral joystick position	
Cooling system	Separate hydraulic oil cooler, hydrostatically driven and thermostatically controlled	
Filter system	Micro cartridge filters in cooling circuit	
Final drive	Heavy-duty combination spur gear with planetary gear, double sealed with electronic seal-integrity indicator	
Control	Single joystick for all travel and steering motions, as well as for counterrotation	



Noise emissions

	PR 754	PR 764
Operator sound exposure ISO 6396	$L_{pA} = 78$ dB(A) emission at the operator's position	$L_{pA} = 79$ dB(A)
Exterior sound pressure 2000/14/EC	$L_{wA} = 113$ dB(A) emission in the environment	$L_{wA} = 114$ dB(A)



Operator's cab

	PR 754	PR 764
Cab	Resiliently mounted cab with positive pressure ventilation, can be tilted with hand pump 40° to the rear. With integrated ROPS Rollover Protective Structure (ISO 3471) and FOPS Falling Objects Protective Structure (ISO 3449)	
Operator's seat	Comfort seat, adjustable to operator's weight	
Monitoring	Combined analogue / LC display, automatic monitoring of abnormal operating conditions	



Undercarriage

	PR 754	PR 764
Design	Undercarriage with rigid or bogie suspension	
Mount	Via separate pivot shafts and an oscillating equaliser bar	
Chains	Lubricated single-bar grouser shoes SESS*, track chain tensioning via steel spring and grease tensioner	
Links, each side	44	44
Track rollers/carrier rollers	7/2 each side	7/2 each side
Sprocket segments	5 each side	3 each side
Track shoes standard	560 mm / 22" SESS	610 mm / 24" SESS
Track shoes optional	610 mm / 24" SESS 660 mm / 26" SESS 710 mm / 28" SESS	660 mm / 26" SESS 710 mm / 28" SESS 760 mm / 30" SESS

* SESS Super Extreme Service Shoes



Hydraulic system

	PR 754	PR 764
System type	Load Sensing proportional pump flow control	
Pump type	Swash plate variable displacement piston pump	
Pump flow max.	261 l/min / 57.4 gpm	352 l/min / 77.9 gpm
Pressure limitation	260 bar / 3,770 PSI	260 bar / 3,770 PSI
Control valve	2 segments, expandable to 4	
Filter system	Return filter with magnetic rod in the hydraulic tank	
Control	Single joystick for all blade functions	



Drawbar pull PR 754/PR 764

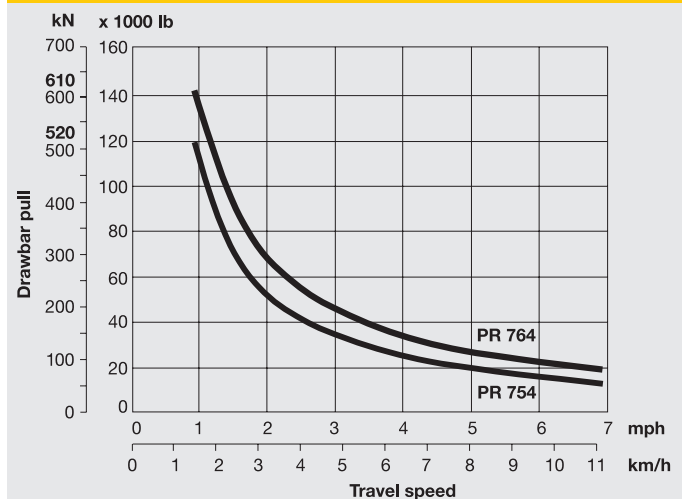

Usable drawbar pull will depend on traction and weight of tractor

Basic machine



Refill capacities in Imp. gallons

	PR 754		PR 764	
Fuel tank	650 l	(143.0 gallons)	860 l	(189.2 gallons)
Cooling system	74 l	(16.3 gallons)	85 l	(18.7 gallons)
Engine oil with oil filters	43 l	(9.5 gallons)	70 l	(15.4 gallons)
Splitter box	5.5 l	(1.2 gallons)	6.4 l	(1.4 gallons)
Hydraulic tank	215 l	(47.3 gallons)	281 l	(61.8 gallons)
Final drive, each	18.5 l	(4.1 gallons)	22.5 l	(4.9 gallons)

Dimensions

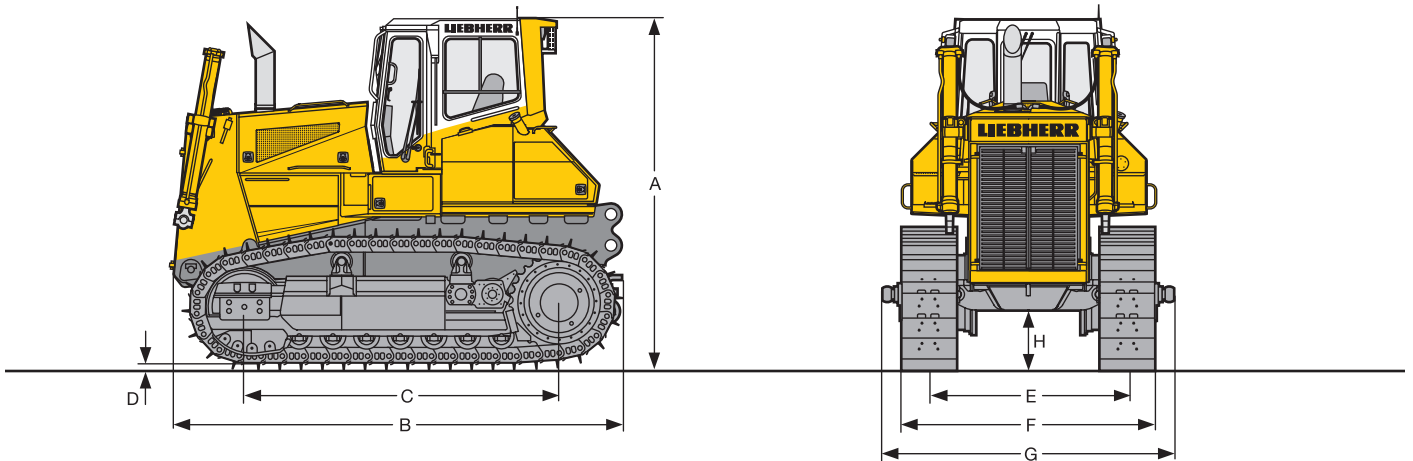

Dimensions		PR 754		PR 764		
		Rigid undercarriage	Single bogie suspension	Rigid undercarriage	Single bogie suspension	Double link bogie suspension
A	Height over cab	mm	3,630		3,935	
		ft-in	11'11"		12'11"	
B	Overall length without attachments	mm	4,875		5,280	
		ft-in	16'0"		17'4"	
C	Distance idler/sprocket center	mm	3,174		3,540	
		ft-in	10'5"		11'7"	
D	Height of grouser	mm	84		84	
		ft-in	3.31"		3.31"	
E	Track gauge	mm	2,180		2,240	
		ft-in	7'2"		7'4"	
F	Total width over tracks	mm	2,749		2,850	
		ft-in	9'0"		9'4"	
G	Total width over blade-mounting trunnions	mm	3,145		3,263	
		ft-in	10'4"		10'8"	
H	Ground clearance	mm	630		695	
		ft-in	2'1"		2'3"	
	Tractor shipping weight ¹	kg	28,947	29,842	37,537	38,037
		lb	63,817	65,790	82,755	83,857
						38,437
						84,739

¹ Includes coolant, lubricants, 20% fuel, ROPS/FOPS cab and track shoes 560 mm/22" for PR 754, track shoes 610 mm/24" for PR 764.

Front attachment

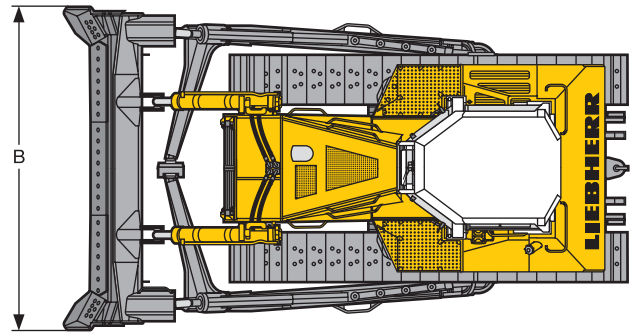
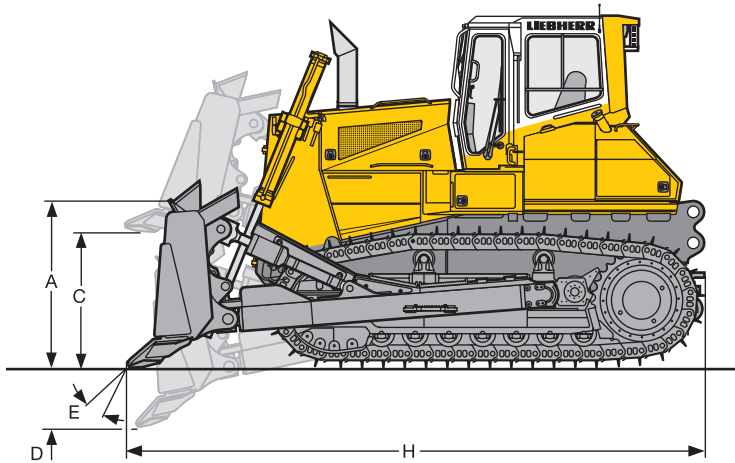

	Semi-U blade	PR 754		PR 764		
		Rigid undercarriage	Single bogie suspension	Rigid undercarriage	Single bogie suspension	Double link bogie suspension
Blade capacity according to ISO 9246	m ³ yd ³	8.9 11.64			13.6 17.79	
A Height of blade	mm ft-in	1,650 5'5"			1,950 6'5"	
B Width of blade	mm ft-in	4,030 13'3"			4,370 14'4"	
C Lifting height	mm ft-in	1,400 4'7"			1,480 4'10"	
D Depth below ground	mm ft-in	570 1'10"			647 2'1"	
E Max. blade pitch		10°			9.4°	
Max. blade tilt	mm ft-in	972 3'2"			1,028 3'4"	
H Overall length	mm ft-in	6,448 21'2"			7,022 23'	
Operating weight ¹ with track shoes 560 mm / 22"	kg lb	34,990 77,140	35,885 79,113	-	-	-
Ground pressure ¹ with track shoes 560 mm / 22"	kg/cm ² PSI	0.98 13.94	1.01 14.36	-	-	-
Operating weight ¹ with track shoes 610 mm / 24"	kg lb	35,225 77,658	36,120 79,631	44,720 98,591	45,220 99,693	45,620 100,575
Ground pressure ¹ with track shoes 610 mm / 24"	kg/cm ² PSI	0.91 12.94	0.93 13.22	1.04 14.79	1.05 14.93	1.06 15.09
Operating weight ¹ with track shoes 710 mm / 28"	kg lb	35,695 78,694	36,590 80,667	45,400 100,090	45,900 101,192	46,300 102,074
Ground pressure ¹ with track shoes 710 mm / 28"	kg/cm ² PSI	0.79 11.23	0.81 11.52	0.90 12.81	0.91 12.94	0.92 13.08
Operating weight ¹ with track shoes 760 mm / 30"	kg lb	-	-	45,680 100,707	46,180 101,809	46,580 102,691
Ground pressure ¹ with track shoes 760 mm / 30"	kg/cm ² PSI	-	-	0.85 12.09	0.86 12.23	0.87 12.37

¹ Includes coolant, lubricants, 20% fuel, ROPS/FOPS cab, semi-U blade, operator

Front attachment

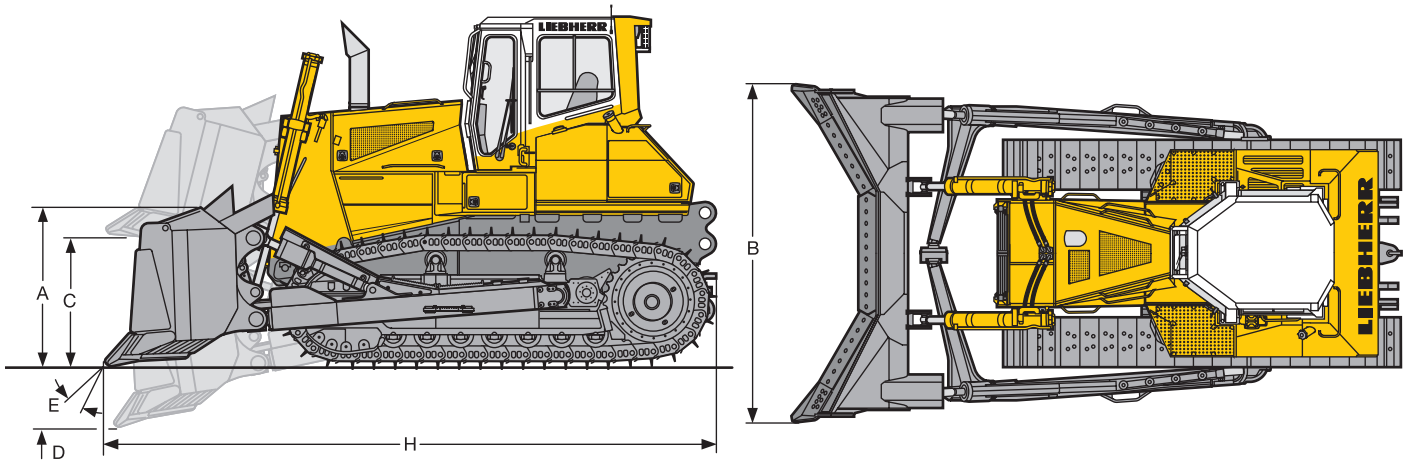

	U blade *	PR 754		PR 764		
		Rigid undercarriage	Single bogie suspension	Rigid undercarriage	Single bogie suspension	Double link bogie suspension
Blade capacity according to ISO 9246	m ³ yd ³	11.7 15.3		17.0 22.23		
A Height of blade	mm ft-in	1,650 5'5"		1,950 6'5"		
B Width of blade	mm ft-in	4,325 14'2"		4,650 15'3"		
C Lifting height	mm ft-in	1,400 4'7"		1,480 4'10"		
D Depth below ground	mm ft-in	570 1'10"		647 2'1"		
E Max. blade pitch		10°		9.4°		
Max. blade tilt	mm ft-in	1,043 3'5"		1,094 3'7"		
H Overall length	mm ft-in	6,915 22'8"		7,549 24'9"		
Operating weight ¹ with track shoes 560 mm / 22"	kg lb	36,090 79,565	36,985 81,538	–	–	–
Ground pressure ¹ with track shoes 560 mm / 22"	kg/cm ² PSI	1.02 14.50	1.04 14.79	–	–	–
Operating weight ¹ with track shoes 610 mm / 24"	kg lb	36,325 77,878	37,220 82,056	45,570 100,465	46,070 101,567	46,470 102,449
Ground pressure ¹ with track shoes 610 mm / 24"	kg/cm ² PSI	0.94 13.37	0.96 13.65	1.06 15.07	1.07 15.22	1.08 15.36
Operating weight ¹ with track shoes 710 mm / 28"	kg lb	36,795 81,119	37,690 83,092	46,250 101,964	46,750 103,066	47,150 103,948
Ground pressure ¹ with track shoes 710 mm / 28"	kg/cm ² PSI	0.82 11.66	0.84 11.94	0.92 13.08	0.93 13.22	0.94 13.37
Operating weight ¹ with track shoes 760 mm / 30"	kg lb	–	–	46,530 102,581	47,030 103,683	47,430 104,565
Ground pressure ¹ with track shoes 760 mm / 30"	kg/cm ² PSI	–	–	0.86 12.23	0.87 12.37	0.88 12.51

* Counterweight or rear attachment is recommended for improved performance and balance.

¹ Includes coolant, lubricants, 20% fuel, ROPS/FOPS cab, U blade, operator.

Rear attachment

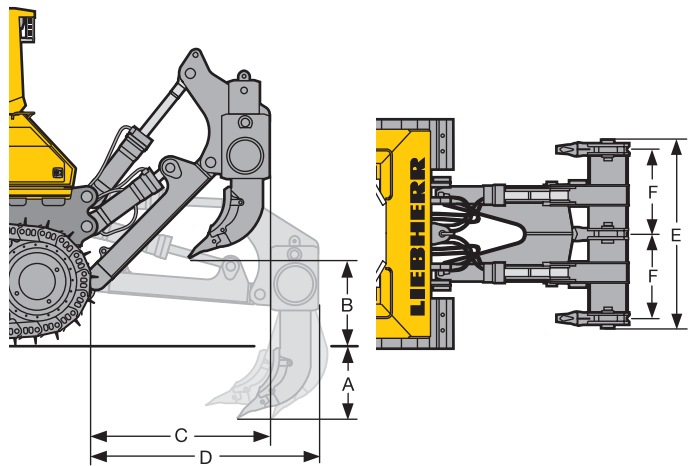
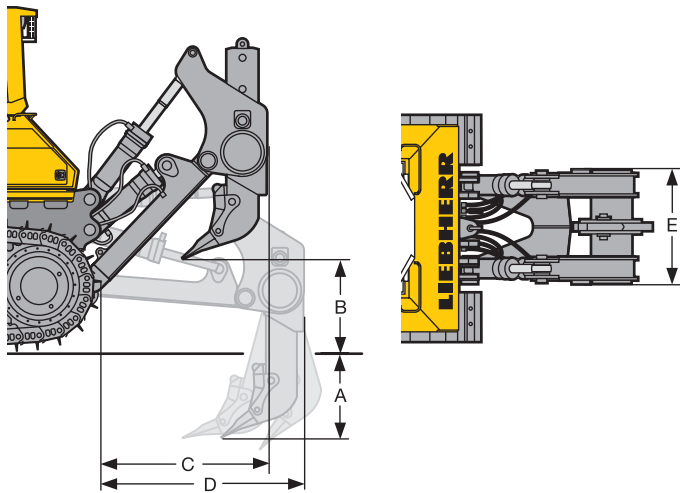

		Ripper single-shank		
		Parallelogram with hydraulic pitch adjustment	PR 754	PR 764
A	Ripping depth (max./min.)	mm	1,201 / 421	1,300 / 476
		ft-in	3'11" / 1'5"	4'3" / 1'7"
B	Lifting height (max./min.)	mm	1,040 / 260	1,000 / 260
		ft-in	3'5" / 10"	3'3" / 10"
C	Overall length, attachment raised	mm	1,821	1,894
		ft-in	6'0"	6'3"
D	Overall length, attachment lowered	mm	2,374	2,494
		ft-in	7'9"	8'2"
E	Ripper width	mm	1,330	1,400
		ft-in	4'4"	4'7"
	Max. shank pitch		31°	31°
	Maximum penetration force	kN	118.2	166.9
		lb	26,563	37,507
	Pryout force	kN	208.8	291.5
		lb	46,924	65,509
	Weight	kg	3,631	4,786
		lb	8,005	10,551

		Ripper multi-shank		
		Parallelogram with hydraulic pitch adjustment	PR 754	PR 764
A	Ripping depth (max./min.)	mm	791 / 476	900 / 520
		ft-in	2'7" / 1'7"	2'11" / 1'8"
B	Lifting height (max./min.)	mm	985 / 670	1,038 / 658
		ft-in	3'3" / 2'2"	3'5" / 2'2"
C	Overall length, attachment raised	mm	1,821	1,894
		ft-in	6'0"	6'3"
D	Overall length, attachment lowered	mm	2,374	2,494
		ft-in	7'9"	8'2"
E	Toolbar width	mm	2,434	2,494
		ft-in	8'0"	8'2"
F	Distance between shanks	mm	1,100	1,130
		ft-in	3'7"	3'8"
	Max. shank pitch		31°	31°
	Maximum penetration force	kN	120.4	176.4
		lb	27,057	39,642
	Pryout force	kN	208.8	291.5
		lb	46,924	65,509
	Weight	kg	4,725	6,160
		lb	10,417	13,580

		Drawbar Rigid		
		PR 754	PR 764	
A	Additional length	mm	463	434
		ft-in	1'6"	1'5"
B	Socket pin diameter	mm	60	60
		ft-in	2.36"	2.36"
C	Height of jaw	mm	619	678
		ft-in	2'0"	2'3"
D	Ground clearance	mm	466	528
		ft-in	1'6"	1'9"
	Jaw opening	mm	105	105
		ft-in	4.13"	4.13"
	Weight	kg	660	750
		lb	1,455	1,653

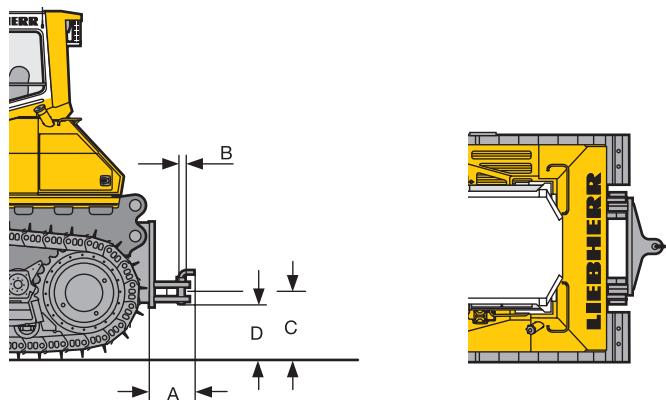

		PR 754	PR 764	
	Counterweight	kg	4,000	5,000
		lb	8,818	11,023
	Counterweight with storage compartment	kg	3,500	-
		lb	7,716	-

Equipment



Basic machine

Tow switch	•
Towing hitch rear	•
Towing lug front	•
Battery compartment, lockable	•
Belly pans, heavy-duty	•
Cold start device, glow plug	•
Radiator, wide-meshed	•
Radiator guard, heavy-duty	•
Radiator guard, hinged	•
Liebherr diesel engine	•
Fan, hydraulically driven	•
Fan guard	•
Engine cover, perforated	•
Engine doors, perforated	•
Engine doors, hinged, lockable	•
Lugs for crane lifting	•
Fuel water separator	•
Air filter, dry-type, dual step	•
Pre-cleaner with automatic dust ejector	•
Toolkit	•
Forestry equipment	+
Landfill equipment	+
Filling with bio-degradable hydraulic oil	+
Tank guard, complete	+
Refuelling pump, electric	+
Diesel particle filter	+
Special paint	+
Fuel water separator with electric heater	+



Travel drive

Parking brake, automatic	•
Function control, automatic	•
Control, single joystick	•
Load limit control, electronic	•
Electronic control	•
Travel control, 3-speed	•
Hydrostatic travel drive	•
Inching brake pedal	•
Emergency stop	•
Oil cooler	•
Final drives planetary gear	•
Safety lever	•



Undercarriage

Track frame, closed	•
Sprocket segments, bolted	•
Master link, two-piece	•
Tracks oil lubricated	•
Undercarriage, rigid	•
Track frames, oscillating	•
Pivot shaft, separate	•
Track shoes with mud hole	+
Track guide centre part	+
Track guard	+
Undercarriage with single bogie suspension	+
Undercarriage with double link bogie suspension	(2) +
Sprocket segments with recesses	+



Electrical system

Starter motor 7.8 kW	•
Working lights, front, 4 units	•
Working lights, rear, 2 units	•
Batteries, cold start, 2 units	•
Battery main switch, mechanical	•
On-board system 24 V	•
Alternator 80 A	•
Horn	•
Back-up alarm	+
Beacon	+
Immobiliser, electronic	+
Additional lights, rear	+
Additional lights, front, on lift cylinders, 4 units	+



Operator's cab

Storage compartment	•
Armrests 3D adjustable	•
Ash tray	•
Pressurised cab with air filter	•
Operator's seat, 6-way adjustable	•
Dome light	•
Coat hook	•
ROPS/FOPS	•
Rear mirror, inside	•
Safety glass, tinted	•
Windshield washer system	•
Windshield wipers front, rear and doors with intermittent function	•
Sliding window, left	•
Sun visor	•
Socket 12 V	•
Warm water heating	•
Operator's seat, air-suspended	+
Fire extinguisher	+
Air conditioning	+
FM radio	+
Radio preinstallation	+
Sliding window, right	+
Protective grids for windows	+
Extension, seat back	+



Control and warning lights

Display travel speed range (digital)	•
Engine coolant temperature gauge (analogue)	•
Fuel gauge (analogue)	•
Hour meter (analogue)	•
Warning light battery charging	•
Warning light diesel engine	•
Warning light electronic travel control system	•
Warning light final drive seal, each side	•
Warning light parking brake	•
Warning light fuel water separator	•
Warning light fan control	•
Warning light pump replenishing pressure	•
Warning light float position blade	•
Warning light oil return filter	•
Warning light air filter	•
Warning light diesel engine preheating	•
Main warning light	•
Warning light hydraulic oil temperature	+



Hydraulic system

Variable flow pump, load sensing	•
Oil filter in hydraulic tank	•
Blade quick drop	•
Control valve for 2 circuits	•
Float position blade	•
Hydraulic servo control	•
Hydraulic control ripper	+
Hydraulic control winch	+
Hydraulic tank oil level warning light	+



Attachments

Mounting plate for external tools	+
Drawbar rear, rigid	+
Counterweight, rear	+
Ripper, 1 shank	+
Ripper, 3 shanks	+
Semi-U blade	+
U blade	+
Winch	+
Spill guard for blade	+

• = Standard
 + = Option
 (1) = only PR 754
 (2) = only PR 764

Subject to changes.

Options and/or special attachments, supplied by vendors other than Liebherr, are only to be installed with the knowledge and approval of Liebherr to retain warranty.

The Liebherr Group of Companies

Wide product range

The Liebherr Group is one of the largest construction equipment manufacturers in the world. Liebherr's high-value products and services enjoy a high reputation in many other fields, too. The wide range includes domestic appliances, aerospace and transportation systems, machine tools and maritime cranes.

Exceptional customer benefit

Every product line provides a complete range of models in many different versions. With both their technical excellence and acknowledged quality, Liebherr products offer a maximum of customer benefits in practical application.

State-of-the-art technology

To provide consistent, top quality products, Liebherr attaches great importance to each product area, its components and core technologies. Important modules and components are developed and manufactured in-house, for instance the entire drive and control technology for construction equipment.

Worldwide and independent

Hans Liebherr founded the Liebherr family company in 1949. Since that time, the enterprise has steadily grown to a group of more than 100 companies with over 32,000 employees located on all continents. The corporate headquarters of the Group is Liebherr-International AG in Bulle, Switzerland. The Liebherr family is the sole owner of the company.

www.liebherr.com



Printed in Germany by Eberl RG-BK-RP LWT/VM 10410614-1.5-06.10_enGB

Liebherr-Werk Telfs GmbH

Hans Liebherr-Straße 35, A-6410 Telfs

☎ +43 50809 6-100, Fax +43 50809 6-7772

www.liebherr.com, E-Mail: lwt.marketing@liebherr.com