

140M

Motor Grader



Cat® C7 ACERT™ VHP

Base Power (1st gear) – Net	136 kW	183 hp
VHP Range – Net	136-148 kW	183-198 hp
VHP Plus Range – Net	136-163 kW	183-218 hp

Gross Vehicle Weight – Base

Total	15 130 kg	33,356 lb
Front Axle	4161 kg	9,173 lb
Rear Axle	10 969 kg	24,183 lb

Moldboard

Blade Width	3.7 m	12 ft
-------------	-------	-------

140M Motor Grader

The 140M delivers multiple technological breakthroughs to give you the best return on your investment.

Operator Station

- ✓ A technologically advanced cab, featuring joystick controls, provides unmatched comfort and visibility. **pg. 4**

Steering and Implement Controls

- ✓ Two joysticks offer precise control and unparalleled ease of operation. This advanced technology makes the 140M the most operator-friendly motor grader in the world. **pg. 6**

Structures, Drawbar, Circle and Moldboard

- ✓ The 140M frame provides a solid working platform, and the DCM delivers service ease and precise blade control for maximum productivity. **pg. 8**

Integrated Electronic Solutions

- ✓ Full systems integration with advanced electronics including Cat® Messenger, AccuGrade™ blade control system and Cat ET, create a “Smart Machine” that optimizes performance and availability. **pg. 14**

All Wheel Drive, Work Tools and Attachments

- ✓ The Work Tools and optional attachments for the 140M, including the industry leading All Wheel Drive system, expand machine versatility, utilization and performance. **pg. 16**

The 140M motor grader represents a revolution in operational efficiency, visibility, service ease and overall productivity, setting the new standard and building on the legacy of high quality you can trust.



Power Train

- ✓ An electronically controlled power shift transmission assures smooth shifting and maximum power to the ground. A modular rear axle and hydraulic brakes simplify serviceability and reduce operating costs. **pg. 10**

Engine

- ✓ The Cat® C7 engine combines power management with ACERT™ Technology to deliver maximum power and efficiency in every gear while reducing the environmental impact. **pg. 12**

Hydraulics

- ✓ The electro-hydraulic load-sensing system provides the foundation for advanced machine controls, enabling superior controllability and precise and predictable hydraulic movements, with the reliability you expect from Caterpillar. **pg. 13**

Safety

- ✓ Caterpillar has been and continues to be proactive in developing machines that meet or exceed safety standards. **pg. 18**

Serviceability and Customer Support

- ✓ Fast component replacement and minimum downtime are possible with Caterpillar's exceptional parts availability and dealers' advanced rebuild and repair capabilities. **pg. 20**



✓ *New Feature*

Operator Station

The 140M features a revolutionary cab design that provides unmatched comfort, visibility and ease of use, making the operator more confident and productive.



Advanced Joystick Controls. Two electro-hydraulic joysticks reduce hand and wrist movement as much as 78% compared to conventional lever controls for greatly enhanced operator efficiency. The intuitive pattern is easy to learn and provides the precise implement control you expect from Caterpillar.

Auxiliary Pod and Ripper Control.

The optional ripper control and auxiliary control pod are ergonomically positioned to allow simple, comfortable operation for the multiple hydraulic options.

Visibility. The 140M boasts excellent visibility to the work area, made possible with angled cab doors, a tapered engine enclosure and a patented sloped rear window.

Cat Comfort Series Seat. The Cat® Comfort Series suspension seat has an ergonomic high-back design, with extra thick contoured cushions and infinitely adjustable lumbar support that evenly distributes the operator's weight. Multiple seat controls and armrests are easy to adjust for optimal support and comfort all day. The optional air suspension seat enhances ride quality for additional comfort.



In-Dash Instrument Cluster.

The instrument panel, with easy-to-read, high-visibility gauges and warning lamps, keeps the operator aware of critical system information.

Cat Messenger. Cat Messenger provides real-time machine performance and diagnostic data. You can quickly view critical performance and operating information, in multiple languages, helping to maximize the life and productivity of the machine.

Controls and Switches. Reliable, long-life rocker switches are located on the right side cab post and front instrument cluster, within easy reach for the operator.

Comfort and Convenience. Caterpillar has built the most comfortable cab in the industry by replacing the control levers and steering wheel with two joystick controls, and lengthening the cab to give more leg room.

Multiple adjustment capabilities for the arm rest, wrist rests and joystick pods help keep the operator comfortable throughout a long shift.



Optional HVAC. The optional heating, ventilation and air conditioning system uses intelligent vent placement for consistent climate control and clear windows for every condition. The high-capacity system dehumidifies air and pressurizes the cab, circulating fresh air and sealing out dust. An easily accessible fresh air filter is located outside the cab at ground level for quick replacement or cleaning.

Optional HVAC Precleaner. Increases the service interval of the HVAC fresh air filter by up to ten times.

Low Interior Sound and Vibration Levels. Isolation mounts for the cab, engine and transmission, in addition to the relocation of the hydraulic pump and valves, provide significant sound and vibration reductions. The low vibration levels and quiet interior provide a comfortable work environment.

Additional Cab Features. Additional cab features include cup holder, lighter and ashtray, coat hook, storage area, night time light, power port and heater. Optional rearview camera, 25 amp power converter and satellite radio are also available.

Steering and Implement Controls

The 140M sets the new standard for motor grader operational efficiency.



Ease of Operation. The revolutionary joystick controls and exceptional visibility make the 140M easier to operate without sacrificing control.

The intuitive joystick control pattern allows both new and experienced operators to become productive quickly.

Logical grouping of hydraulic functions in the joysticks allow any operator to easily control several functions at the same time. This allows the operator to be more productive and remain comfortable throughout the work shift.

Intuitive Steering Control. The 140M introduces a breakthrough in joystick steering control. This technology creates a direct relationship between the lean angle of the joystick and the turning angle of the steer tires.

A brake tensioning system holds the joystick in position until the operator moves it. In addition, the steering control automatically reduces steering sensitivity at higher ground speeds for comfortable and predictable control.

Electronic Throttle Control. Electronic Throttle Control (ETC) provides the operator with easy, precise, and consistent throttle operation. An automatic and manual mode on a single switch offers flexibility for different applications and operator preferences.



Left Joystick Functions. The left joystick primarily controls the machine direction and speed.

- 1 – Steering: Lean joystick left and right
- 2 – Articulation: Twist joystick left and right
- 3 – Articulation Return to Center: Yellow thumb button
- 4 – Wheel Lean: Two black thumb buttons
- 5 – Direction: Index trigger shifts transmission to forward, neutral or reverse
- 6 – Gear Selection: Two yellow thumb buttons upshift and downshift
- 7 – Left moldboard lift cylinder: Push joystick to lower, pull joystick to raise
 - Left moldboard lift cylinder float: Pushing joystick through detent engages float

Articulation Return-to-Center.

This exclusive feature automatically returns the machine to a straight frame position from any articulation angle with the touch of a single button. Return-to-Center helps improve productivity and safety by allowing the operator to focus on controlling the moldboard.



Right Joystick Functions. The right joystick primarily controls the Drawbar, Circle and Moldboard functions.

- 1 – Right moldboard lift cylinder: Push joystick to lower, pull joystick to raise
 - Right moldboard lift cylinder float: Pushing joystick through detent engages float
- 2 – Moldboard slide: Lean joystick left and right
- 3 – Circle turn: Twist joystick left and right
- 4 – Moldboard tip: Thumb switch fore and aft
- 5 – Drawbar center shift: Thumb switch left and right
- 6 – Electronic Throttle Control: Trigger switch is resume and decrement
- 7 – Differential Lock/Unlock: Yellow button



1 – Ripper Control Pod. Infinitely variable roller switches control the rear ripper and/or front lift group (when equipped), for easy and comfortable control.

2 – Programmable Auxiliary Hydraulic Pod. Four fingertip controls and a mini joystick maximize hydraulic control flexibility, accommodating up to six hydraulic circuits. Individual functions are easily programmable through Cat ET to meet the configuration you need.

The optional auxiliary hydraulic pod is provided in addition to the ripper control pod when the machine is configured with three or more auxiliary functions.

Structures, Drawbar, Circle and Moldboard

Durable structures with fast and simple DCM adjustments deliver precise material control while lowering operating costs.



Front Frame Structure. The 140M front frame is a formed structural carbon steel tube. Advanced fabrication technology significantly reduces the number of weld joints, which more evenly distributes stress loads. The result is a robust machine that delivers the durability you expect from Caterpillar.

Rear Frame Structure. The box-sectioned hitch design helps resist torsion loads and ensure structural durability. The integrated bumper ties the rear frame together as a single, solid unit, so the frame can withstand heavy-duty applications such as ripping and winging snow.

Articulation Hitch. A large tapered roller bearing at the lower pivot carries loads evenly and smoothly. This joint is sealed to prevent contamination in this critical area.

A mechanical locking pin prevents frame articulation to help ensure safety when servicing or transporting the machine.

Circle Construction. Our one-piece forged steel circle is built to stand up to high stress loads and provide structural durability. The front 240° of circle teeth are hardened to reduce wear and ensure component reliability.

Drawbar Construction. The A-frame drawbar features a tubular design for high strength and optimum durability.

Aggressive Blade Angle. With a long wheelbase the operator can obtain aggressive moldboard angles, so material rolls more freely along the length of the blade. This is particularly helpful when handling very dry materials or cohesive soils. Better material control gets the job done faster, requires less power and saves fuel.

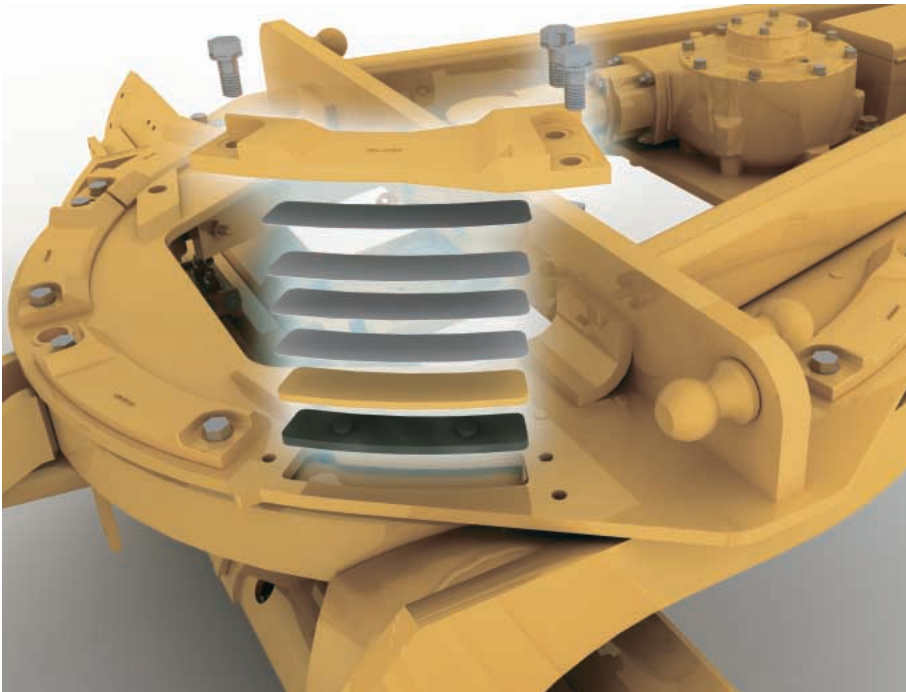

Top-adjust drawbar wear strips

Top-Adjust Drawbar Wear Strips.

The patented top-adjust wear strips dramatically reduce drawbar/circle adjustment time. By removing the access plates on top of the drawbar, shims and wear strips can easily be added or replaced. This feature reduces service downtime and lowers overall machine operating costs.

Replaceable Wear Inserts.

Tough, durable nylon composite wear inserts reduce rotational friction for maximum circle torque and longer component life. They are located between the drawbar and circle, and between the support shoes and circle. High load-resistant brass wearstrips are placed between the blade mounting group and moldboard. This sacrificial wear system can be replaced easily and helps keep components tight for fine grading.

Moldboard. The optimal curvature and large throat clearance help move material quickly and efficiently. Heat-treated moldboard rails, hardened cutting edges and end bits, and large diameter bolts assure reliability and longer service life. The moldboard side shift cylinder is positioned on the left side to eliminate snow wing interference.

Moldboard Positioning. The blade link bar design extends the possibilities for moldboard positioning, most beneficial in mid-range bank sloping and in ditch cutting and cleaning.

Shimless Moldboard Retention System. The unique shimless moldboard retention system reduces the potential for blade chatter. Vertical and horizontal adjusting screws keep the moldboard's wear strips aligned for precise blade control and dramatic reductions in service time.

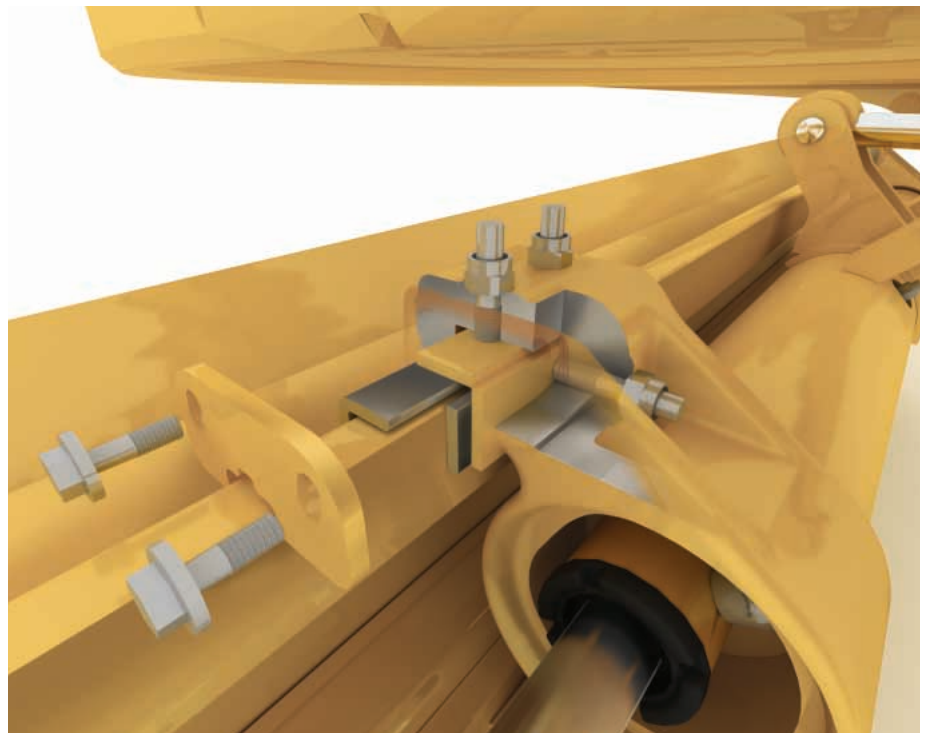

Shimless moldboard retention system with adjusting screws

Power Train

Integrated, electronically controlled systems, deliver smooth reliable performance with reduced operating costs.

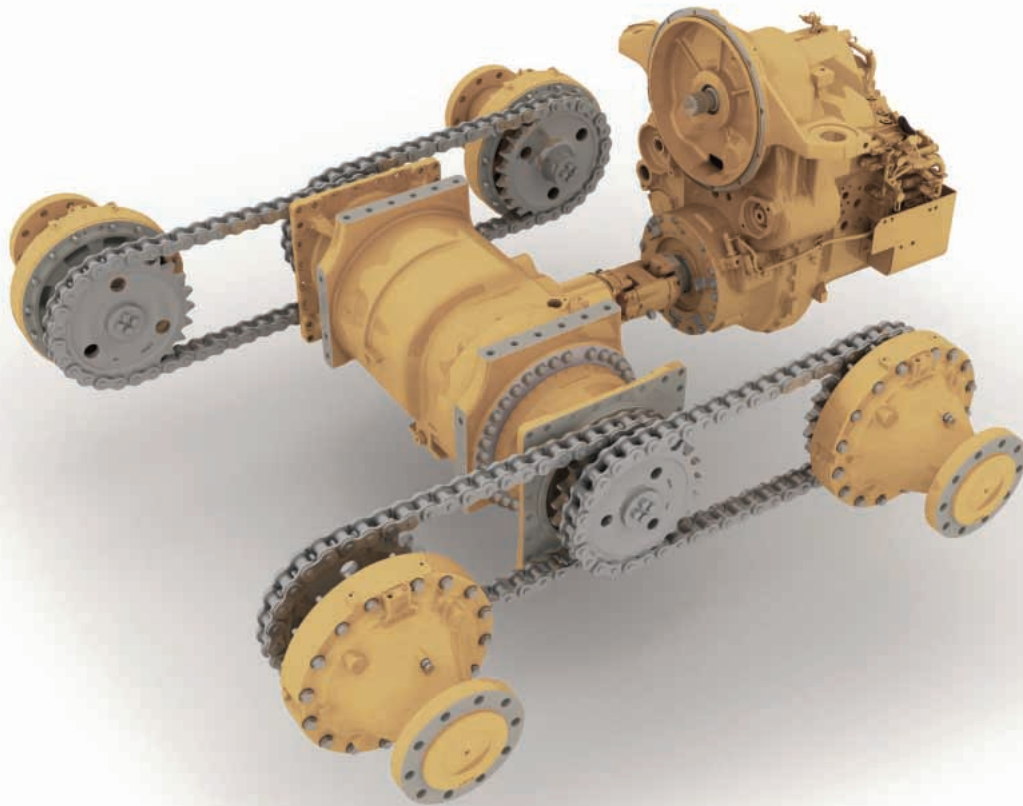

Smooth Shifting Transmission. The 140M combines several key innovations to ensure smooth, powerful shifts throughout the gear range.

Electronically Controlled Shifting. The full Electronic Clutch Pressure Control (ECPC) system optimizes inching modulation and smooths shifting between all gears and directional changes. This provides outstanding control and also extends the life of the transmission by reducing stress on gears.

Load Compensation. This standard feature ensures consistent shift quality regardless of blade or machine load.

Controlled Throttle Shifting. This standard feature helps to smooth directional and gear changes without use of the inching pedal.

Engine Over-Speed Protection. Helps protect the transmission and extend component life by preventing downshifting until a safe travel speed has been established.

Power Shift Countershaft Transmission. Designed and manufactured specifically for the 140M motor grader, the direct drive countershaft transmission is matched with the powerful Cat C7 engine to maximize power to the ground.

Modular Rear Axle. The 140M incorporates a bolt-on modular rear axle design, which offers easy access to differential components, improves serviceability and contamination control, and lowers maintenance time and operating costs. The result is a rugged machine you can rely on for years to come.

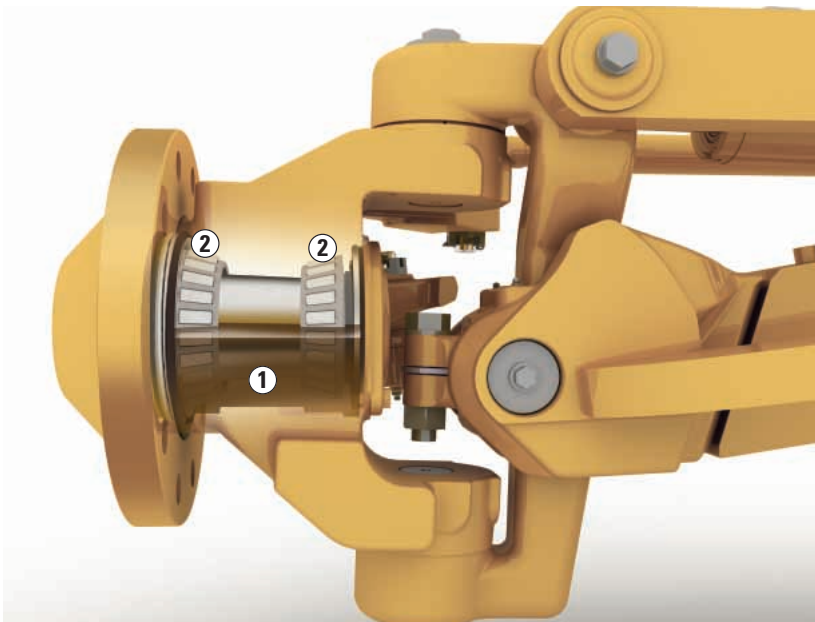

Front axle

Front Axle. The Caterpillar® sealed spindle keeps the bearings free from contaminants and lubricated in a light-weight oil (1). This durable, low-maintenance design reduces your owning and operating costs. Two tapered roller bearings (2) support the wheel spindle. The Cat “Live Spindle” design places the larger tapered roller bearing outboard where the load is greater, extending bearing life.

Gear Selection. Eight forward and six reverse gears give the operator a wide operating range. The specifically designed range of gears ensures maximum productivity in all earthmoving applications.

Inching Pedal. Allows precise control of machine movements in any gear with low pedal effort and excellent modulation, critical in close-quarter work or finish grading.

Programmable Autoshift. The operator can easily customize various shift parameters through Cat Messenger to match the specific application requirement. This feature automatically shifts the transmission at optimal points so the operator can focus on the work, improving safety, productivity and ease of operation.

Hydraulic Brakes. The oil bathed, multi-disc service brakes are hydraulically actuated (1), providing smooth predictable braking and lower operating costs. With brakes located at each tandem wheel, the 140M offers the largest total brake surface area in the industry (2), delivering dependable stopping power and longer brake life.

Brake Serviceability and Reliability. An easily accessible brake wear indicator/compensator system (3) maintains consistent brake performance and indicates brake wear without disassembly. This system cuts service time and extends brake service life.

Parking Brake. The spring-applied, hydraulically released multi-disc parking brake is a sealed, oil-cooled design extending component life and reducing the need for service. The parking brake is integrated into the Operator Presence System to prevent unintended machine movement.

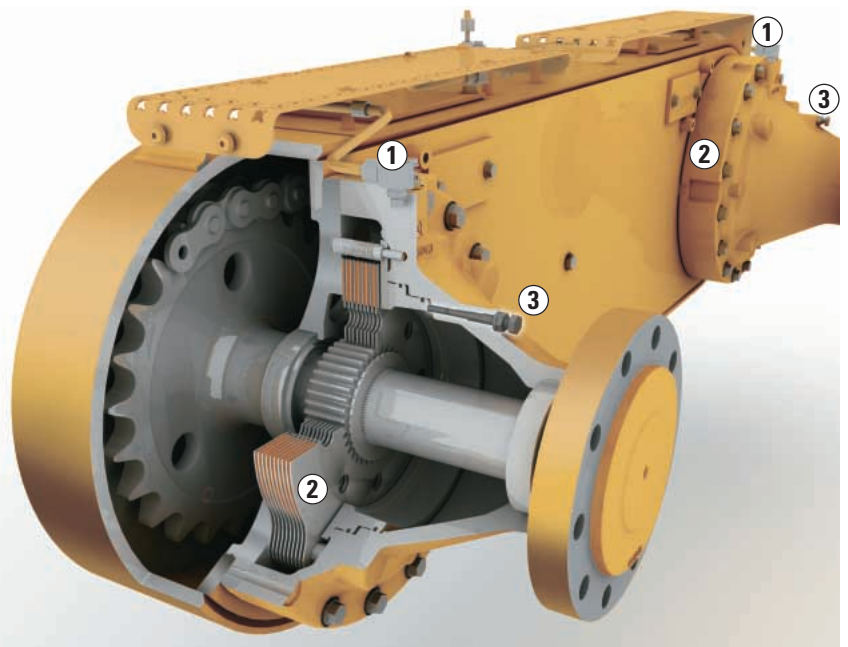

Brake design

Engine

The 140M combines power management with ACERT™ Technology to deliver maximum power and efficiency while reducing the environmental impact.

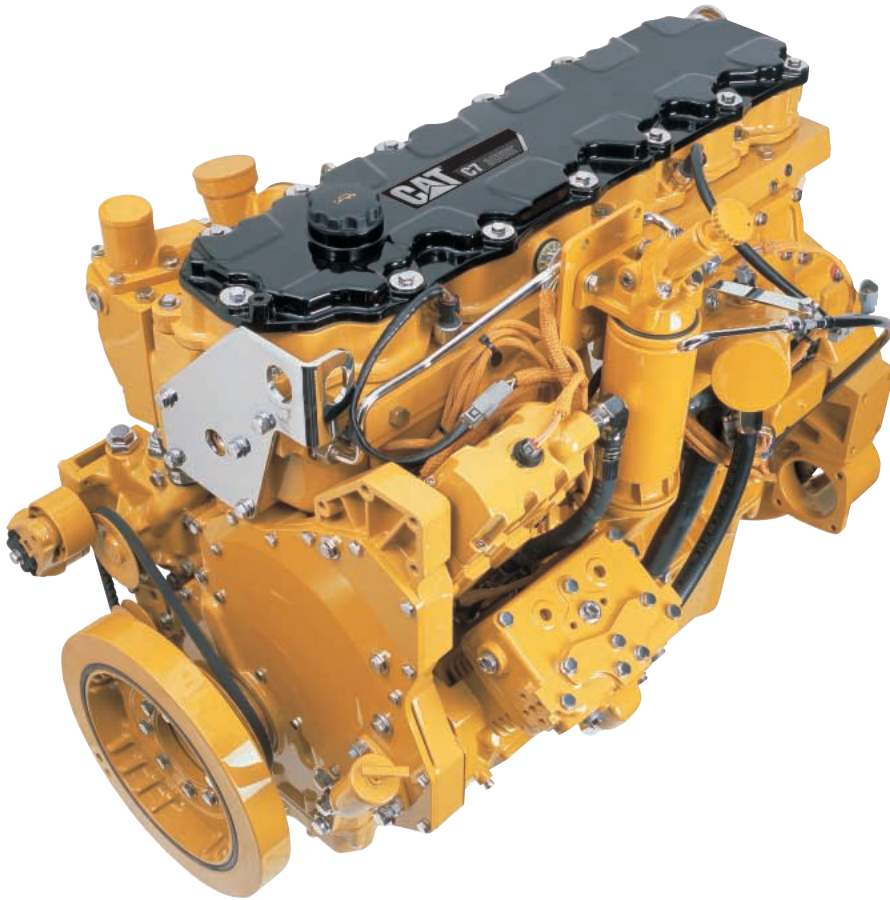

ACERT™ Technology.

ACERT Technology allows Cat engines to supply more power per unit of displacement without causing premature wear. This breakthrough technology reduces emissions during the combustion process by using advanced technology in the air and fuel systems, in conjunction with integrated electronics. ACERT Technology enhances overall engine performance while dramatically reducing exhaust emissions.

Fuel Delivery. The C7 engine with ACERT Technology uses multiple injection fuel delivery to precisely shape the combustion cycle. Several small ignitions lower combustion chamber temperatures, generates fewer emissions and optimizes fuel combustion. Bottom line: more work output for your fuel cost.

Power Management. The 140M Power Management System automatically delivers an additional five horsepower in each forward gear 1st through 4th, and each reverse gear 1st through 3rd. This standard feature optimizes rimpull for all gears by balancing traction, speed and horsepower while conserving fuel. The system limits horsepower in lower gears, which helps reduce wheel slip where traction is limited. With the Variable Horsepower Plus (VHP Plus) option, an additional five-horsepower is delivered in each forward gear 5th through 8th for more power at higher speeds.



Performance. The Cat C7 engine meets specific performance requirements for 140M applications. Its superior torque and lugging capability can pull through sudden, short-term increases in loads, maintaining consistent, desirable grading speeds to get the work done faster without downshifting.

Hydraulic Demand Fan. The hydraulic demand fan automatically adjusts cooling fan speed according to engine cooling requirements. This system reduces demands on the engine, putting more horsepower to the ground and improving fuel efficiency.

Exhaust Emissions Compliant. The Cat C7 with ACERT Technology meets or exceeds all U.S. EPA Tier 3 and European Union Stage IIIa emissions control standards.

Hydraulics

The 140M electro-hydraulics enable advanced machine controls with precise and predictable movements.



Advanced Electro-Hydraulic System.

The 140M incorporates a state-of-the-art electro-hydraulic system. This technology is the foundation for revolutionary changes of the machine and implement controls. Advanced joystick controls provide unmatched controllability with precise, predictable hydraulic movements and the reliability you expect from Caterpillar.

Blade Float. Blade float is built into the blade lift control valves and is optional for some auxiliary hydraulic functions. The blade float feature allows the blade to move freely under its own weight. By floating both cylinders, the blade can follow the contours of the road when removing snow. Floating only one cylinder permits the toe of the blade to follow a hard surface while the operator controls the slope with the other lift cylinder.

Cat® XT™ Hose. Caterpillar hose technology allows high pressures for maximum power and reduced downtime. Intelligent routing minimizes exposure to damage. Hose clips prevent hose rubbing and excessive vibration for lower owning and operating costs.

Independent Oil Supply. Large, separate hydraulic oil supply prevents cross-contamination and provides proper oil cooling, which reduces heat build-up and extends component life.

Load Sensing Hydraulics (PPPC).

The time proven load-sensing system and the advanced Proportional Priority Pressure-Compensating (PPPC, or “triple-PC”) electro-hydraulic valves on the 140M are designed to provide superior implement control and enhanced machine performance in all applications. Continuous matching of hydraulic flow and pressure to power demands creates less heat and reduces power consumption.

Consistent and Predictable Movement.

PPPC valves have different flow rates for the head (red) and rod ends (blue) of the cylinder. This ensures consistent extension and retraction speeds for each cylinder, and gives the operator a consistent and predictable response every time an implement control is moved.

Balanced Flow. Hydraulic flow is proportioned to ensure all implements operate simultaneously with little effect on the engine or implement speeds. If demand exceeds pump capacity, all cylinder velocities are reduced by the same ratio. The result is improved productivity in all applications.

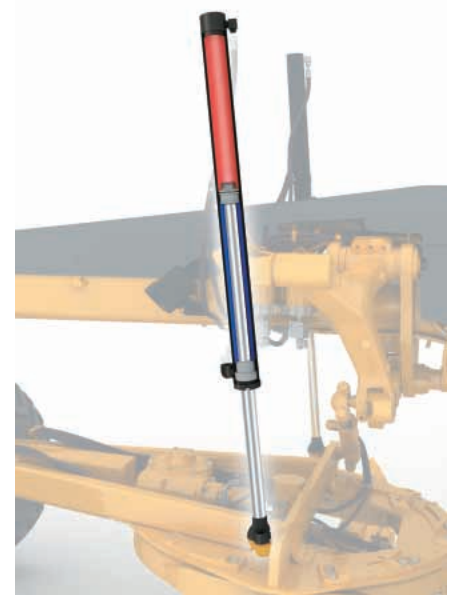

Predictable movements

Integrated Electronic Solutions

Full systems integration optimizes machine performance and availability.



140M with AccuGrade™ System

“Smart Machine”. The 140M fully integrates all core systems creating a “Smart Machine.” The Cat data link shares key data among systems, optimizing machine performance while preventing potential machine damage.

Diagnostics. Cat Messenger, combined with full systems integration, enhances the diagnostic capability of the 140M. Machine system errors are displayed in text as well as with fault codes, allowing service technicians and operators to quickly analyze critical data, increasing machine availability.

Optional Automatic Blade Control.

The Caterpillar AccuGrade System automatically controls the blade, improving operator efficiency and productivity. AccuGrade™ technology reduces the need for traditional survey stakes or grade checkers, so you can reach grade faster and in fewer passes than ever before.

AccuGrade Attachment Ready Option.

The AccuGrade System is fully integrated into the machine design, making installation quick and easy. Integral hydraulic and electrical components are standard on the 140M (Grade Control Ready). The AccuGrade Attachment Ready Option provides additional mounting brackets, cab controls and electrical harnesses for easy installation of the Cross Slope, Sonic, Laser, GPS or ATS electronics kits.

Product Link. The optional Product Link system streamlines diagnostic efforts, and reduces downtime, maintenance scheduling and costs by providing a communication flow of vital machine data and location. Product Link gives automatic updates on machine parameters such as machine hours, machine condition, location, fault codes and alarms directly to your office computer.

Electronic Technician (Cat ET). Cat ET is a two-way communication tool that gives service technicians easy access to stored diagnostic data and lets them configure the machine parameters through the Cat Data Link. This integrated feature reduces machine downtime and lowers operating costs.



Cat Messenger. Standard on the 140M, Cat Messenger provides real-time machine performance and diagnostic data with an easy-to-use interface. Messenger monitors all system data and alerts the operator of any faults through a digital text display that can be shown in multiple languages.



Low Battery Elevated Idle. After the 140M is at low idle for an extended period and low system voltage is detected, idle speed is raised. This ensures adequate system voltage and improves battery reliability.

Automatic Engine Deration. Protects the C7 engine by automatically lowering engine torque output and alerting the operator if critical conditions are detected.



Machine Security System (MSS). The optional MSS uses electronically coded keys to limit usage by specific individuals or times of the day. MSS deters theft, vandalism and unauthorized use.

All Wheel Drive, Work Tools and Attachments

The All Wheel Drive, Work Tools and optional attachments for the 140M expand machine versatility, utilization and performance.



All Wheel Drive (AWD) System.

The optional AWD system utilizes dedicated left and right pumps for precise hydraulic control. The infinitely variable pumps and motors maximize torque in each gear delivering the most power to the ground in the industry and increasing productivity in the most demanding applications.



Precise control

AWD – Constant Net Power.

When equipped with AWD, the 140M will automatically increase the gross power up to 26 kW (35 hp) when the system is engaged. This offsets the parasitic losses and maintains a constant net power to the ground for maximum productivity.

AWD – Hydrostatic Mode. Standard with AWD, this mode disengages the transmission and provides hydraulic power to the front wheels only. The ground speed is infinitely variable between 0-8 km/h (0-5 mph), perfect for precise finish work.

AWD – Steering Compensation.

The Caterpillar exclusive Steering Compensation System is standard with All Wheel Drive. This feature enables a “powered turn” by adjusting the outside front tire speed up to 50% faster than the inside tire. The result is improved control, less damage to surfaces and a dramatic reduction of turning radius in poor underfoot conditions.

■ Without Steering Compensation ■ With Steering Compensation

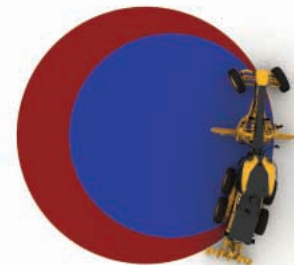

Moldboard Options. A 3.7 m (12 ft) moldboard is standard on the 140M, with an optional 4.3 m (14 ft) moldboard available from the factory. Left and right side moldboard extensions are also available, increasing versatility.

Ground Engaging Tools (GET). A wide variety of Caterpillar GET is available on the 140M, including cutting edges, graderbits and end bits, all designed for maximum service life and productivity.

Front Mounted Groups. A front mounted push plate/counterweight or front lift group can be ordered on the 140M. The Caterpillar Work Tools front lift group can be combined with a front dozer blade or front scarifier for added versatility.



Rear Ripper/Scarifier. The 140M optional ripper/scarifier is made to penetrate tough material fast and rip thoroughly for easier material movement with the moldboard. The ripper includes three shanks with the ability to add two more if needed. Nine scarifier shanks can also be added for additional versatility.

Snow Removal Work Tools.

Caterpillar Work Tools offer a variety of snow removal equipment specifically for the 140M. Multiple snow plow, snow wing and mounting options are available, adding additional machine versatility and utilization throughout the year.

Automatic Lubrication System.

The optional Lincoln Automatic Lubrication System maintains the proper grease lubrication on working surfaces, significantly extending component life. Contaminants are purged from open pins and bushings to help prevent dirt from damaging critical components.

Air Compressor. An optional air compressor is available, giving you a convenient on-board air system to blow debris off the machine and operate power tools.

Fast-Fill Fuel Option. The 140M offers a Fast-Fill option allowing customers to refuel in less than two minutes for fast, accurate filling and reduced downtime.

Safety

Safety is an integral part of all machine and system designs.



Operator Presence System. The Operator Presence System keeps the parking brake engaged and hydraulic implements disabled until the operator is seated and the machine is ready for safe operation.

Secondary Steering System. The standard secondary steering system automatically engages an electric hydraulic pump in case of a drop in steering pressure, allowing the operator to steer the machine to a stop.

Speed Sensitive Steering. The steering software automatically provides an infinitely variable ratio between the joystick and the steer tires, resulting in less sensitive steering as the ground speed increases.

Low Sound and Vibration Levels.

Isolation mounts for the cab, engine and transmission maximize operator comfort and help to minimize sound and vibration. These modifications provide a quieter and more comfortable working environment, optimizing operator focus.

Hydraulic Lockout. A simple switch located in the cab disables all implement functions while still providing machine steering control. This safety feature is especially useful while the machine is roading.

Brake Systems. Brakes are located at each tandem wheel to eliminate braking loads on the power train. In addition, the brake systems are redundant and utilize accumulators to enable stopping in case of machine failure, further increasing operational safety.

Drop-Down Rear Lights. Optional drop-down lights fold out from the rear of the machine. This creates a wider, lower profile to be better aligned with passenger cars.

Rearview Camera. Visibility is further enhanced with an optional Work Area Vision System (WAVS) through a 178 mm (7 in) LCD color monitor in the cab. Developed specifically for rugged applications, this durable camera improves productivity and increases operator awareness of surroundings.

High Intensity Discharge (HID) Lighting. Optional HID lights can replace the standard halogen lamps. The powerful HID lights are four times brighter, improving night time visibility and safety.



Steel Tandem Walkways. Perforated raised steel walkways cover the tandems. This provides a sturdy platform for standing and walking, and additional protection for the brake lines.

ROPS/FOPS Cab. Isolation mounted to the frame to reduce vibration and sound, the integral ROPS/FOPS structure meets ISO and SAE criteria for operator protection.

Circle Drive Slip Clutch. This standard feature protects the drawbar, circle and moldboard from shock loads when the blade encounters an immovable object. It also reduces the possibility of abrupt directional changes in poor traction conditions, protecting the machine, operator and surroundings.

Blade Lift Accumulators. This optional feature uses accumulators to help absorb impact loads to the moldboard by allowing vertical blade travel. Blade lift accumulators reduce unnecessary wear and help to avoid unintended machine movement for increased operator safety.

Engine Shutoff Switch. An engine shutoff switch is located at ground level on the left rear of the machine, allowing anyone nearby to shut it down in case of an emergency.

Electrical Disconnect Switch. A battery disconnect switch, located inside the left rear enclosure, provides ground-level lockout of the electrical system to prevent inadvertent starting of the machine.



Fenders. To help reduce objects flying from the tires, as well as build-up of mud, snow and debris, optional fenders can be added.

Additional Safety Features. The 140M has many additional standard safety features, including laminated glass on the front windows and doors, lockable doors, back-up lights and sounding alarm, black glare-reducing paint on the front frame and engine enclosure, and conveniently located grab rails for added safety.

Serviceability and Customer Support

Simplified service, world-class product support and Cat® dealer-trained experts keep your fleet up and running, maximizing your equipment investment.



Grouped Service Points. The 140M groups daily service points in the left side service center to help ensure proper maintenance and inspection routines.

Extended Service Intervals. The 140M extended service intervals, such as 500-hour engine oil changes and 4000-hour hydraulic oil changes, reduce machine service time and increase availability.

Ecology Drains. Conveniently located ecology drains shorten service times and help keep the environment safe by preventing spills.

Diagnostics and Monitoring. The 140M integrates Cat Messenger, Cat Electronic Technician and S•O•SSM Sampling ports for easy monitoring and fast troubleshooting, keeping your machine up and running.

Machine Selection. Make detailed comparisons of the machines under consideration before purchase. Cat dealers help you size the right machine for your operations and can estimate component life, preventative maintenance cost, and the true cost of production.

Purchase. Consider the financing options available, as well as day-to-day operating costs. Look at dealer services that can be included in the cost of the machine to yield lower equipment owning and operating costs over the long run.

Maintenance Services. Repair option programs guarantee the cost of repairs up front. Diagnostics programs such as Scheduled Oil Sampling, S•O•SSM analysis, Coolant Sampling and Technical Analysis help avoid unscheduled repairs.



Product Support. You will find nearly all parts at our dealer parts counter. Cat dealers use a world-wide computer network to track in-stock parts to minimize machine down time. Save money with genuine Cat Reman parts. You receive the same warranty and reliability as new products at substantial cost savings.

Engine

Engine Model	Cat® C7 ACERT™ VHP	
Base Power (1st gear) – Net	136 kW	183 hp
VHP Range – Net	136-148 kW	183-198 hp
VHP Plus Range – Net	136-163 kW	183-218 hp
Displacement	7.2 L	439 in ³
Bore	110 mm	4.3 in
Stroke	127 mm	5 in
Torque Rise	39%	
Max Torque	1079 N•m	796 lb-ft
Speed @ Rated Power	2,000 rpm	
Number of Cylinders	6	
Derating altitude	3048 m	10,000 ft

Std – Fan speed	– Max	1,450 rpm	
	– Min	550 rpm	
Std – Ambient Capability	43° C	109° F	
Hi Ambient – Fan speed	– Max	1,650 rpm	
	– Min	550 rpm	
Hi Ambient Capability	50° C	122° F	

- Net power is tested per ISO 9249, SAE J1349, and EEC 80/1269 Standards in effect at the time of manufacture.
- VHP Plus is an optional attachment.
- Net power advertised is the power available at rated speed of 2,000 rpm, measured at the flywheel when engine is equipped with fan running at minimum speed, air cleaner, muffler and alternator.
- No engine derating required up to 3048 m (10,000 ft).

140M Net Power

Gear	VHP	VHP Plus
	kW (hp) – Net	kW (hp) – Net
Fwd. 1st	136 (183)	136 (183)
	2nd	140 (188)
	3rd	144 (193)
	4th	148 (198)
	5th	148 (198)
	6th	148 (198)
	7th	148 (198)
	8th	148 (198)
Rev. 1st	136 (183)	136 (183)
	2nd	140 (188)
	3rd – 6th	144 (193)

Power Train

Forward/Reverse Gears	8 Fwd/6 Rev	
Transmission	Direct drive, power shift, Countershaft	
Brakes – Service	Multiple oil-disc	
– Service, Surface Area	23 000 cm ²	3,565 in ²
– Parking	Multiple oil disc	
– Secondary	Dual circuit control system	

All-Wheel Drive System (Optional)

Motor Type	2 Infinitely variable axial piston	
Pump Type	2 Variable piston	
Maximum Torque	13 998 N•m	10,325 lb-ft
Operational Gears	Forward = 1-7 Reverse = 1-5	

Hydraulic System

Circuit Type	Electro-hydraulic load sensing, closed center	
Pump Type	Variable piston	
Pump Output	210 L/min	55.7 gal/min
Maximum System Pressure	24 150 kPa	3,500 psi
Standby Pressure	3100 kPa	450 psi

- Pump output measured at 2,150 rpm

Operating Specifications

Top Speed – Fwd.	46.6 km/h	29 mph
– Rev.	36.8 km/h	22.9 mph
Turning Radius, Outside Front Tires	7.75 m	25 ft 6 in
Steering Range – Left/Right	47.5°	
Articulation Angle – Left/Right	20°	
Fwd. 1st	4 km/h	2.5 mph
2nd	5.5 km/h	3.4 mph
3rd	8 km/h	5 mph
4th	11 km/h	6.8 mph
5th	17.1 km/h	10.6 mph
6th	23.3 km/h	14.5 mph
7th	32 km/h	19.9 mph
8th	46.6 km/h	29 mph
Rev. 1st	3.2 km/h	2 mph
2nd	6 km/h	3.7 mph
3rd	8.7 km/h	5.4 mph
4th	13.5 km/h	8.4 mph
5th	25.3 km/h	15.7 mph
6th	36.8 km/h	22.9 mph

Service Refill

Fuel Capacity	416 L	110 gal
Cooling System	47 L	12.4 gal
Hydraulic System – Tank	60 L	15.9 gal
Engine Oil	30 L	7.9 gal
Trans./Diff./Final Drives	65 L	17.2 gal
Tandem Housing (each)	64 L	16.9 gal
Front Wheel Spindle Bearing Housing	0.9 L	0.24 gal
Circle Drive Housing	7 L	1.8 gal

Frame

Circle – Diameter	1530 mm	60.2 in
– Blade Beam Thickness	40 mm	1.6 in
Drawbar – Height	152 mm	6 in
– Width	76.2 mm	3 in
Front Frame Structure		
– Height	305 mm	12 in
– Width	305 mm	12 in
– Thickness	16 mm	0.6 in
Front Axle		
– Height to Center	571 mm	23 in
– Wheel Lean, Left/Right	18°	
– Total Oscillation Per Side	32°	

Tandems

Height	506 mm	19.9 in
Width	201 mm	7.9 in
Sidewall Thickness – Inner	16 mm	0.6 in
– Outer	18 mm	0.7 in
Drive Chain Pitch	50.8 mm	2 in
Wheel Axle Spacing	1523 mm	60 in
Tandem Oscillation – Front Up	15°	
– Front Down	25°	

Moldboard

Moldboard – Width	3.7 m	12 ft
– Height	610 mm	24 in
– Thickness	22 mm	0.87 in
Arc Radius	413 mm	16.3 in
Throat Clearance	166 mm	6.5 in
Cutting Edge – Width	152 mm	6 in
– Thickness	16 mm	0.6 in
End Bit – Width	152 mm	6 in
– Thickness	16 mm	0.6 in
Blade Pull – Base GVW	9873 kg	21,766 lb
– Max GVW	13 458 kg	29,670 lb
– Base GVW (AWD)	14 229 kg	31,370 lb
– Max GVW (AWD)	20 769 kg	45,787 lb
Down Pressure – Base GVW	7216 kg	15,908 lb
– Max GVW	14 087 kg	31,057 lb

- Blade pull calculated at 0.9 traction coefficient, which is equal to ideal no-slip conditions, and Gross Machine Weight.

Blade Range

Circle Centershift – Right	728 mm	28.7 in
– Left	695 mm	27.4 in
Moldboard Sideshift – Right	660 mm	26 in
– Left	510 mm	20.1 in
Maximum Blade Position Angle	90°	
Blade Tip Range – Forward	40°	
– Backward	5°	
Maximum Shoulder Reach Outside of Tires		
– Right	1978 mm	77.9 in
– Left	1790 mm	70.5 in
Maximum Lift Above Ground	480 mm	18.9 in
Maximum Depth of Cut	715 mm	28.1 in

Ripper

Ripping Depth, Maximum	428 mm	16.8 in
Ripper Shank Holders	5	
Ripper Shank Holder Spacing	533 mm	21 in
Penetration Force	9026 kg	19,900 lb
Pryout Force	8555 kg	18,861 lb
Machine Length Increase, Beam Raised	919 mm	36.2 in

Scarifier

Front, V-Type, 5 or 11 Tooth

Working Width	1205 mm	47.4 in
Scarifying Depth, Maximum	467 mm	18.4 in
Scarifier Shank Holders	5/11	
Scarifier Shank Holder Spacing	116 mm	4.6 in

Mid, V-Type

Working Width	1184 mm	46.6 in
Scarifying Depth, Maximum	292 mm	11.5 in
Scarifier Shank Holders	11	
Scarifier Shank Holder Spacing	116 mm	4.6 in

Mid, Straight

Working Width	1800 mm	71 in
Scarifying Depth, Maximum	317 mm	12.5 in
Scarifier Shank Holders	17	
Scarifier Shank Holder Spacing	111 mm	4.4 in

Rear

Working Width	2300 mm	91 in
Scarifying Depth, Maximum	266 mm	10.5 in
Scarifier Shank Holders	9	
Scarifier Shank Holder Spacing	267 mm	10.5 in

Weights

Gross Vehicle Weight – Base

– Total	15 130 kg	33,356 lb
– Axle	4161 kg	9,173 lb
– Rear Axle	10 969 kg	24,183 lb

Gross Vehicle Weight – Max

– Total	23 077 kg	50,875 lb
– Front Axle	8123 kg	17,908 lb
– Rear Axle	14 954 kg	32,967 lb

- Base operating weight calculated on standard machine configuration with 14.00-24 10PR (G-2) tires, full fuel tank, coolant, lubricants and operator.

Standards

ROPS/FOPS	ISO 3471/ISO 3499
Steering	ISO 5010:1992
Brakes	ISO 3450
Sound	ISO 6394/ISO 6395

- The static sound operator pressure level measured according to ISO 6394:1988 for a cab offered by Caterpillar, when properly installed, maintained and tested with doors and windows closed and hydraulic fan at maximum speed is 70 dB(A).
- The dynamic spectator sound power level for the standard machine when equipped with sound suppression package and hydraulic fan running at 70% of maximum speed, machine sound measured is less than 106 dB(A), complying with EU 2000/14/EC requirement.

Dimensions

All dimensions are approximate based on standard machine configuration with 14.00-24 10PR (G-2) tires.

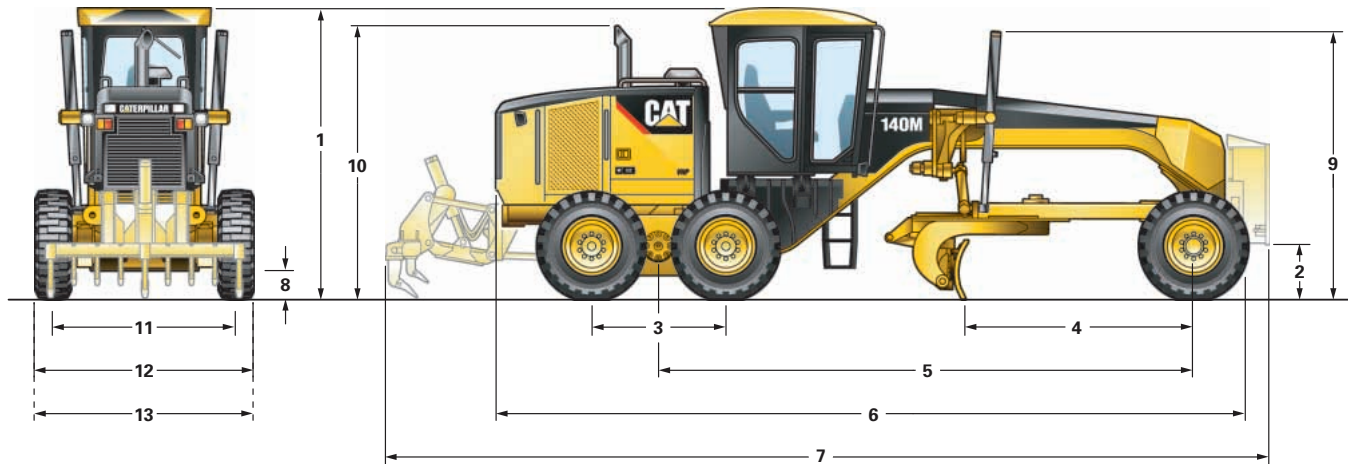

1	Height – Top of Cab	3293 mm	129.6 in
2	Height – Front Axle Center	571 mm	22.5 in
3	Length – Between Tandem Axles	1523 mm	60 in
4	Length – Front Axle to Moldboard	2552 mm	100.5 in
5	Length – Front Axle to Mid Tandem	6121 mm	241 in
6	Length – Front Tire to Rear of Machine	8713 mm	343 in
7	Length – Counterweight to Ripper	10 144 mm	399.4 in

8	Ground Clearance at Rear Axle	341 mm	13.4 in
9	Height to Top of Cylinders	3040 mm	119.7 in
10	Height to Exhaust Stack	3124 mm	123 in
11	Width – Tire Center Lines	2127 mm	83.7 in
12	Width – Outside Rear Tires	2493 mm	98.1 in
13	Width – Outside Front Tires	2493 mm	98.1 in

Standard Equipment

Standard equipment may vary. Consult your Caterpillar dealer for details.

OPERATOR ENVIRONMENT

- Armrest, adjustable
- Articulation, automatic Return-to-Center
- Ashtray and lighter
- Cat Messenger, operator information system
- Centershift pin indicator
- Coat hook
- Cup holder
- Display, digital speed and gear
- Door, driver access (left side) with wiper
- Gauge cluster – articulation, engine coolant temp, engine RPM, fuel, system voltage
- Gauge, machine level
- Heater, cab
- Hour meter, digital
- Joystick hydraulic controls
 - implements, steering, transmission
- Lights, night time cab
- Mirror, inside rearview, wide angle
- Power port, 12V
- ROPS cab, sound suppressed
- Seat belt, retractable 76 mm (3 in)
- Seat, cloth-covered, comfort suspension
- Storage area for cooler/lunchbox
- Throttle control, electronic
- Windows, laminated glass:
 - fixed front with intermittent wiper
 - right side with dual wipers, (door optional)
- Windows, side and rear (3)
- Wrist rests, adjustable

POWER TRAIN

- Air cleaner, dual stage, dry type, automatic dust ejector, service indicator through Cat Messenger
- Air-to-air after cooler (ATAAC)
- Belt, serpentine, automatic tensioner
- Brakes, four-wheel hydraulic
- Differential, lock/unlock
- Drain, engine oil
- Electronic over speed protection
- Engine, Cat® C7 with ACERT™ Technology
- Fuel-water separator
- Hydraulic demand fan
- Muffler, under hood
- Parking brake – multi-disc, sealed, oil-cooled
- Priming pump, fuel
- Rear axle, modular
- Sediment drain, fuel tank
- Transmission, 8F/6R, power shift, direct drive
- VHP (Variable Horsepower)

ELECTRICAL

- Alarm, back up
- Alternator, 80 ampere, sealed
- Batteries, maintenance free, 880 CCA
- Breaker panel, ground accessible
- Electrical system, 24V
- Grade Control Ready – Cab harness, software, electrical hydraulic valves, bosses and brackets
- Lights, reversing
- Lights, stop and tail, LED
- Product Link Ready

OTHER STANDARD EQUIPMENT

- Brake accumulators, dual certified
- Bumper, rear, integrated with hitch
- Clutch, circle drive slip
- Cutting edges
 - curved DH-2 steel
 - 203 mm × 16 mm (8 in × 5/8 in)
 - 19 mm (3/4 in) mounting bolts
- Doors (3), engine compartment, locking
- Drawbar – 6 shoe with replaceable wear strips
- Endbits
 - 16 mm (5/8 in) DH-2 steel
 - 19 mm (3/4 in) mounting bolts
- Extended Life Coolant to –35° C (–30° F)
- Fluid check, ground level
- Frame, articulated, with safety lock
- Fuel tank, ground level access
- Ground level engine shutdown
- Hammer (emergency exit)
- Horn, electric
- Hydraulics, base 8 implement controls
- Hydraulics, load-sensing
- Lockout, hydraulic implement for roading
- Moldboard
 - 3658 mm × 610 mm × 22 mm (12 ft × 24 in × 7/8 in)
 - hydraulic sideshift and tip
- Paint, glare reducing – top of front frame and rear enclosure
- Radiator cleanout access
- Secondary steering
- Serviceability, LH side
- S•O•SSM ports: engine, hydraulic, transmission, coolant, fuel
- Tandem walkway/guards
- Tool box
- Tow hitch

TIRES, RIMS, & WHEELS

- Partial allowance for tires and multi-piece rims

Optional Equipment

Optional equipment may vary. Consult your Caterpillar dealer for details.

	kg	lb
ELECTRICAL		
Alternator, 150 ampere	2	5
Batteries:		
Extreme Duty, 1400 CCA	14	30
Heavy Duty, 1125 CCA	7	15
Converter, Communication (CB)	5	11
Lights:		
13 Lighting Arrangements, Including HID Options and Rear Rooding, Drop Down		
Warning: Beacon or Strobe	2	5
GUARDS		
Covers, Screen	4	9
Debris	9	20
Sound	110	243
Transmission	141	310
OPERATOR ENVIRONMENT		
Air Conditioner with Heater	49	107
Door, Cab, Right Hand Side	11	25
Fan, Defroster, Rear Window	2	4
Mirrors, Outside:		
Heated 24V	15	33
Mounted	10	22
Precleaner, HVAC	5	10
Radio Ready, AM/FM or Satellite	9	20
Seat, Air Suspension, Cloth	2	5
Shade, Sun	2	5
Wiper, Each Side	0	1
Wiper/washer, Rear	2	4
POWER TRAIN		
All Wheel Drive	590	1,300
Engine, Variable Horsepower Plus (VHP Plus)		
Fuel Tank, Fast Fill	14	31
Oil, Hydraulic, Biodegradable Synthetic		
Precleaner, Sy-Klone	9	20
Transmission, Autoshift	2	5

	kg	lb
OTHER ATTACHMENTS		
AccuGrade ARO	39	85
Accumulators, Blade Lift	77	170
AutoLube, Lincoln	23	50
AutoLube, Lincoln, Ripper Enhancement	5	10
Camera, Rearview	9	20
Caterpillar Product Link 321SR	5	10
Compressor/Tank, Air	23	50
Drain, Ecology, Engine Wiggins	2	5
Fenders, Front, AWD	56	124
Fenders, Rear	119	262
Heater, Engine Coolant:		
120V	1	3
220V	1	3
Hydraulic arrangements with one or more additional hydraulic valves are available for rear ripper, dozer, snow plow and snow wing.		
Ladder, Cab, Right Hand Side	7	15
Security System	2	5
Snow Wing Mounting, Frame Ready	91	200
Sound Suppression	15	32
Starting Aid, Ether	0.5	1
WORK TOOLS/G.E.T.		
Blade Extension, 610 mm (2 ft)		
Right or Left Hand	147	325
Cutting Edges, Curved	43	95
Endbits, Overlay	24	52
Front Lift Group, Mechanical	680	1,500
Grader Bit, Narrow and Super Penetration	181	400
Mid Mount Scarifier, Mounting	57	125
Moldboard		
4267 mm × 610 mm × 22 mm (14 ft × 24 in × 7/8 in)		
4267 mm × 686 mm × 25 mm (14 ft × 27 in × 1 in)		
Push Plate, Counterweight	907	2,000
Ripper, Mounting	32	70
Ripper, Rear	962	2,120
Ripper Tooth	28	61
Scarifier, Front	434	956
MACHINE ARRANGEMENTS		
European Arrangement		
Rooding Arrangement, European		
Snow Arrangement		

Notes

140M Motor Grader

For more complete information on Cat products, dealer services,
and industry solutions, visit us on the web at www.cat.com

© 2007 Caterpillar
All Rights Reserved
Printed in U.S.A.

Materials and specifications are subject to change without notice.
Featured machines in photos may include additional equipment.
See your Caterpillar dealer for available options.

CAT, CATERPILLAR, their respective logos, "Caterpillar Yellow" and the
POWER EDGE trade dress, as well as corporate and product identity used herein,
are trademarks of Caterpillar and may not be used without permission.

AEHQ5731-01 (5-07)

CATERPILLAR®