

23,8 – 26,1 t, 150 hp

VOLVO EXCAVATOR

ECR235CL



MORE CARE. BUILT IN.



THE PERFECT FIT TO YOUR JOBSITE.

MORE SAFETY.

- **Anti-slip, punched steel steps/platforms:** superior grip and safety.
- **Low engine emission levels and low noise.**
- **Lead-free exterior paint** is in harmony with the environment.
- **Cab door slides neatly along the cab,** staying within the track width.
- **Optional rear-view camera:** increased visibility and safety.

MORE PRODUCTIVITY.

- **Class-leading stability** for powerful lifting performance.
- **Smooth combination boom/arm operation -** even during travel.
- The combination of **brute power and fine, precision control.**
- **Powerful Stage IIIA Volvo engine:** performance, durability and industry-leading fuel efficiency.
- **Volvo quick fit:** easy attachment change out for greater versatility.
- **Optional dozer blade:** high blade departure angle allows for steep slope climbing.





MORE COMFORT.

- **Volvo Care Cab:** comfort you expect.
- **High-capacity climate control system.**
- **Spring applied, viscous cab mounting:** reduced whole body vibration.
- **Adjustable consoles** make it easy to find the right operating position.

MORE INNOVATION.

- **Short swing radius:** work in confined areas where space is limited.
- **Excellent center of gravity for smooth balance** when swinging on slopes.
- **New, rounded cab shape:** roomy, yet compact design stays inside the counterweight swing radius.

MORE UPTIME.

- **Large service openings** for easy access/inspection.
- **Centralized lubrication points and ground-level filter access.**
- **In-cab monitoring** through the easy-to-read, **color LCD monitor.**

MORE QUALITY.

- **Volvo durability built in:** forged steel top rollers, strengthened track guard, greased/sealed track link.
- **Strong undercarriage frame:** endures daily abuse.
- **Reinforced superstructure:** double welded stress points.

ROUND OUT YOUR PRODUCTION.

Versatility and day-after-day reliability. When you have one machine that you can count on for both – you're going to be very productive. The Volvo ECR235CL delivers. It's the short swing radius machine you need to get you in and out of confined areas with ease. It's also a powerful 24-ton worker that has the capacity and stability you need for the big jobs. With optimum all-around performance, you're ready for it all.

Short swing radius

- The performance of a conventional excavator – with the flexibility you want from a short swing radius.
- Used in open areas and confined jobsites for greater versatility.
- Counterweight swing radius extends over the track width by less than 10%.

Volvo Care Cab comfort

- Rounded cab shape is roomy for the operator, yet designed to compactly stay inside the counterweight swing radius.
- High-capacity climate control system: operator comfort from cab floor to ceiling.

Work where the profits are

- Operate in or next to streets with minimal traffic disruption.
- More safety next to buildings, people or other site obstructions: less risk of machine damage.
- Fewer restrictions/permits: more job opportunities.

Never short on performance

- A heavy counterweight and excellent center of gravity.
- The short swing radius machine with class-leading stability.

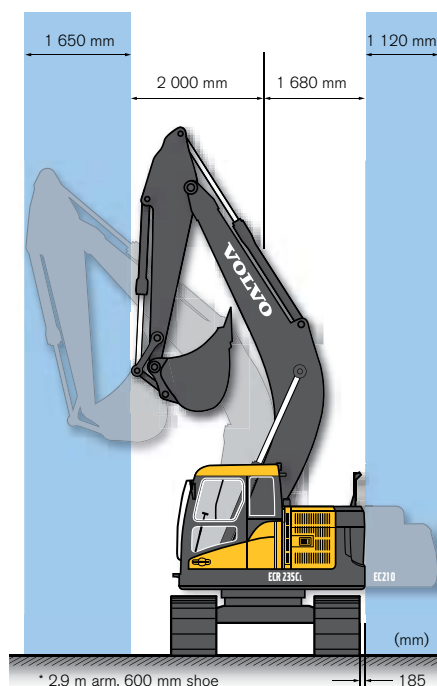



• Operate safely in a single lane of traffic.



• Rounded design with a compact swing radius.



• Volvo: the name you can trust for quality.



YOUR EDGE ON THE JOBSITE.

You find the job and the Volvo ECR235CL will help you finish it. From wide open areas to confined spaces and on slopes or flat ground – it handles it all with class-leading stability and smooth, precise control. Get the Volvo edge on your jobsite.

A stable performer

- Optimum capacity and stability, comparable with conventional machines.
- With a heavier counterweight and excellent center of gravity, the Volvo ECR235CL was designed to offer comparable stability/balance as a conventional machine when swinging on slopes – and performing on flat terrain.

Smooth, fast work

- Class-leading short swing radius lifting capability, swing torque, weight distribution and tractive effort.
- Smooth combination boom/arm operation.
- Machine's computer balances maximum available horsepower to hydraulic output.

The right fit for the job

- Works in one lane of traffic: avoiding costly permits or night-only work mandates.
- Volvo quick fit compatibility: easy attachment change out for greater versatility.

Precision control

- The combination of brute power and fine, precision control.
- Volvo-matched hydraulics deliver optimum productivity, command and less operator fatigue.
- Optional dozer blade features a high blade departure angle that allows steeper slope climbing. Provides extra bracing stability when digging.

Application versatility

- **City/public works:** pipe and cable laying, sewer and drainage work.
- **Road works:** road construction, piping and utilities.
- **Waste handling:** effective inside confined facilities.
- **Demolition:** accessing areas conventional machines can not.
- **Forestry:** channel work, forestry thinning, light logging, road construction.
- **Mining:** work in narrow/low ceiling mines and tunnels.





EASY TO WORK. HARD AT WORK.

Climb in after a few quick checks and you're on your way to another productive day. The Volvo ECR235CL is built with Volvo quality for long life and durability. And with ease of service and leading fuel efficiency, it's also going to be another profitable year.

Volvo quality runs through and through

- Reinforced superstructure, forged steel top roller, strengthened track guard, greased/sealed track link.
- Performance and durability, along with industry-leading fuel efficiency and low noise/emissions.
- Powerful Stage IIIA Volvo engine.

Access to serviceability

- Large service openings for easy access/inspection.
- Long hydraulic oil service intervals: standard at 5 000 hours.
- All daily service checks are accessible at ground level – and viewable from the cab monitor.
- Centralized lubrication points and ground-level filter access.
- Approximately 80% commonality of components with Volvo conventional machines: reduced costs and greater availability.

Your Volvo dealer has the support you need:

CareTrack helps track your machine

- Optional GPS monitoring and diagnostics program.
- Remotely track machine location, usage, productivity, fuel consumption and more.
- Maximize uptime through important service reminders.

MATRIS gives you a full report

- Detailed operating history analysis, utilization and efficiency.
- Turns the data captured inside the machine's computer into easy-to-use graphs and reports.
- Check operating techniques, reduce maintenance costs and increase service life.





• Ground level air filter access.



• 3-point, multi-purpose access with hand rail for ease and safety.



• Wide open, ground level service area provides easy hydraulic valve access.



VOLVO KNOWS WHAT MATTERS: YOU.

Legendary Volvo comfort and safety. It comes standard with every Volvo machine. The Volvo ECR235CL is the right fit for the operator, the jobsite and the environment. Work with peace of mind – and body, and get more of something else that matters: profit.

Comfort increases productivity

- High-capacity climate control system.
- Class-leading cab leg room and space, along with a wide shoulder position.
- Spring applied, viscous cab mounting: reduced whole body vibration.
- Low internal and external noise: less fatigue.

Perfect for every operator

- Adjustable consoles make it easy to find the right operating position.
- Full suspension seat – with numerous adjustments to suit all operators.
- LCD color monitor is easy to read – even in direct sunlight. Content viewable in over 20 languages.
- Easy-lift front windshield – stows securely under the roof line – for plenty of headroom.
- Lower front glass is removable and stores safely inside the cab.

Safe on the jobsite

- Anti-slip, punched steel steps and platforms offer superior grip and safety.
- Opening roof hatch offers an optimal view during high-reach applications.
- Cab door slides neatly along the cab, staying within the track width for easy access in confined surroundings.
- Optional rear-view camera: increased visibility and safety.

A concern for our surroundings

- Excellent visibility to the front, right-hand side and rear due to narrow cab pillars and large windows.
- 95% recyclable materials used in the machine.
- Lead-free paint is in harmony with our environment.

Volvo: your global, local partner

- Complete solutions since 1927.
- Built on the core values of quality, safety and environmental care.
- Construction equipment, commercial transport, buses, trucks and more.
- Global expertise: development of engines with leading fuel efficiency.





• Plenty of interior foot space and leg room.



• LCD color monitor is bright and easy to read.



• Optional rear view camera increases safety.



VOLVO'S ENGINE LEADERSHIP SPANS LAND, SEA, SKY AND SPACE

As the world's largest manufacturer of 9-to-18-liter diesel engines, Volvo has unmatched expertise designing power systems that move the world. Volvo engines for Volvo Construction Equipment, Volvo

Aero, Volvo Buses, Volvo Penta and Volvo Trucks define productivity and fuel economy. Our performance has been honed on land, over the sea, across the sky and into space. Leading research and development keeps

all Volvo Group products at the forefront of productivity. So when we say Volvo engines are tested — and proven — you can believe it. Trust in it. It's the real advantage of Volvo Power.



CUSTOMIZED TO ORDER.

Your options are open. Make your Volvo Excavator just right for you and your work. To customize your excavator with other optional equipment features to suit your application, contact your local Volvo dealer.

Hydraulic kits

A wide variety of hydraulic kits are available for various boom and arm combinations. Each kit maximizes performance according to the machine's boom and arm length/shape. Get the most out of rotating/tilting attachments, crushers and hammers. Choose between 1 or 2 pump flow for best performance.

Hydraulic quick fit

A Volvo hydraulic quick fit makes changing attachments quick and easy – all from the comfort and safety of the cab. Two different Volvo quick fit types (universal, S1) are available to fit new and existing customer's buckets/ attachments, making it very user friendly.

Extra work lights

Extra work lights provide increased visibility, safety and precision, while extending the workday in low light conditions. Features one light in the front of the machine, one light in the rear area of the cab and one light mounted on the upper structure.

Wrist control joysticks - proportional control

Low-effort, wrist control joysticks provide smooth, precision control for increased comfort, efficiency and production. Wrist control joysticks with proportional control switches are also available.

Operator seats

Volvo offers a wide variety of ergonomic operator seats designed specifically for comfort and protection. All seats, from various adjustable models to the most advanced air-suspended models, provide excellent support and are individually adjustable to suit operator preferences.

Straight travel pedal

A pedal located by the left foot rest operates two travel motors at the same time, providing convenience when traveling and efficient work control in applications such as pipe laying.

Rear view camera

Inside the cab, the wide screen color LCD of the IECU (Instrument Electronic Control Unit) provides a safe rear view when reverse travel is selected or of the right hand side of the superstructure when the slew function is activated. The protected rear and side view cameras can be switched manually using the selection switch on the keypad.

Dozer blade

A front-end dozer blade increases machine versatility in job applications such as backfilling trenches and site clean up. It can also be used to level the excavator when working on slopes.

CareTrack

GPS monitoring program that works with the machine's diagnostic system. Allows the owner and dealer to remotely track usage, productivity, fuel consumption and more. Maximizes uptime through important service reminders. Also monitors geographic machine location and can even prevent unauthorized use.

Extended greasing bushings

High quality bushings used on all important work equipment to lengthen greasing intervals to 500 hours. Extends life, reduces wear on the pins/bushings and reduces maintenance costs.



VOLVO OPTIONAL EQUIPMENT

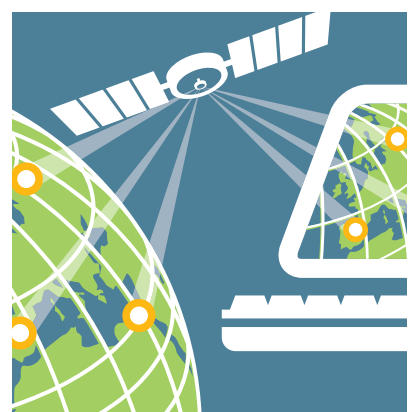
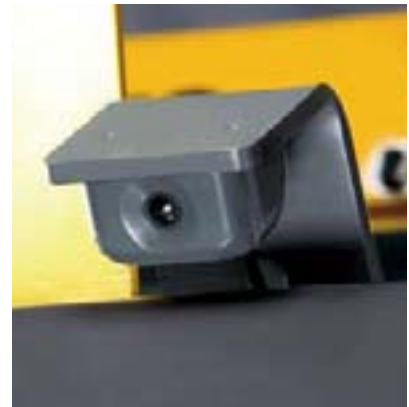

Hydraulic kits
Hydraulic quick fit
Extra work lights

**Wrist control joysticks -
proportional control**
Operator seats
Straight travel pedal

Rear view camera
Dozer blade
CareTrack

NOTE: Some features listed as optional equipment are standard equipment in some markets. Some equipment features listed are not available in all markets. Not a complete list of available optional equipment features. See included specification sheet for a complete listing.

SPECIFICATIONS

Engine

The next-generation Volvo diesel engine uses Volvo Advanced Combustion Technology (V-ACT) to deliver lower emissions and maintain superior performance and fuel efficiency. The EU Stage IIIA compliant engine uses precise, high-pressure fuel injectors, turbo charger and air to air intercooler and electronic engine controls to optimize machine performance.

Engine	Volvo D6E EAE3
Max. power, at	30 r/s (1 800 r/min)
Net (ISO 9249, SAE J1349)	110 kW (150 hp)
Gross (SAE J1995)	123 kW (167 hp)
Max. torque at 1 350 r/min	730 Nm
No. of cylinders	6
Displacement	5,7 l
Bore	98 mm
Stroke	126 mm

Electrical system

High-capacity electrical system that is well protected. Waterproof double-lock harness plugs are used to secure corrosion-free connections. The main relays and solenoid valves are shielded to prevent damage. The master switch is standard.

Voltage	24 V
Batteries	2 x 12 V
Battery capacity	150 Ah
Alternator	28 V / 80 A

Service refill capacities

Fuel tank	325 l
Hydraulic system, total	220 l
Hydraulic tank	125 l
Engine oil	25 l
Engine coolant	26,5 l
Swing reduction unit	5 l
Travel reduction unit	2 x 5 l

Swing system

The swing system uses an axial piston motor, driving a planetary gearbox for maximum torque. An automatic holding brake and anti-rebound valve are standard.

Max. swing speed	10,8 r/min
Max. swing torque	82,5 kNm

Drive

Each track is powered by an automatic two-speed shift travel motor. Track brakes are multi-disc, spring-applied and hydraulically released. The travel motor, brake and planetary gears are well protected within the track frame.

Max. drawbar pull	200 kN
Max. travel speed	3,0/5,3 km/h
Gradeability	35°

Undercarriage

The undercarriage has a robust X-shaped frame. Greased and sealed track chains are standard.

Track pads	2 x 49
Link pitch	190 mm
Shoe width,	500/600/
triple grouser	700/800/900 mm
Shoe width,	
triple grouser HD	600 mm
Shoe width,	
double grouser HD	700 mm
Shoe width,	
rubber pad	600 mm
Bottom rollers	2 x 9
Top rollers	2 x 2

Hydraulic system

The hydraulic system, also known as the "Integrated work mode control" is designed for high-productivity, high-digging capacity, high-maneuvering precision and excellent fuel economy. The summation system, boom, arm and swing priority along with boom, arm and bucket regeneration provides optimum performance.

The following important functions are included in the system:

Summation system: Combines the flow of both hydraulic pumps to ensure quick cycle times and high productivity.

Boom priority: Gives priority to the boom operation for faster raising when loading or performing deep excavations.

Arm priority: Gives priority to the arm operation for faster cycle times in leveling and for increased bucket filling when digging.

Swing priority: Gives priority to swing functions for faster simultaneous operations.

Regeneration system: Prevents cavitation and provides flow to other movements during simultaneous operations for maximum productivity.

Power boost: All digging and lifting forces are increased.

Holding valves: Boom and arm holding valves prevent the digging equipment from creeping.

Main pump:
Type: 2 x variable displacement axial piston pumps
Maximum flow: 2 x 200 l/min

Pilot pump:
Type: Gear pump
Maximum flow: 1 x 18 l/min

Hydraulic motors:

Travel: Variable displacement axial piston motor with mechanical brake

Swing: Fixed displacement piston motor with mechanical brake

Relief valve setting:

Implement 32,4/34,3 MPa

Travel circuit 34,3 MPa

Swing circuit 27,9 MPa

Pilot circuit 3,9 MPa

Hydraulic cylinders:

Mono boom 2

Bore x Stroke ø130 x 1 420 mm

Arm 1

Bore x Stroke ø135 x 1 540 mm

Bucket 1

Bore x Stroke ø120 x 1 065 mm

Dozer Blade 2

Bore x Stroke ø140 x 320 mm

Cab

Purpose-designed, rounded, short radius Volvo Care Cab with no sacrifice to operator comfort. Audio system with remote control. Cup holders. 3 high-capacity outlets. Independently adjustable joystick consoles.

Excellent all around-visibility provided through maximum cab glass, transparent roof hatch and 2-piece sliding door window. The lift-up front windshield can easily be secured at the ceiling and the removable lower front glass can be stored inside the cab. Interior lighting consists of one reading light and one cab light with timer.

The pressurized and filtered cab air is supplied by an 8-vent climate-control system, providing fast defrosting and high cooling and heating performance. Viscous/spring-mounted suspension cushions operator from vibrations.

Deluxe seat with adjustable height, tilt, recline, forward-back settings, retractable seat belt and selectable horizontal suspension for reduced whole body vibration.

Adjustable easy-to-read 16,3 cm (6,4") LCD color monitor provides real time information of machine functions, important diagnostic information and a wide variety of work tool settings. LCD monitor is switchable to rear-view camera monitor (option).

Sound Level:

Sound level in cab according to ISO 6396

..... LpA 72 dB(A)

External sound level according to ISO 6395 and EU Directive 2000/14/EC

..... LwA 101 dB(A)

Ground pressure

- **ECR235CL** with 5,7 m boom, 2,9 m arm, 693 kg bucket, 6 150 kg counterweight

Description	Shoe width	Operating weight	Ground pressure	Overall width
Triple grouser	500 mm	23 870 kg	59,8 kPa	2 890 mm
	600 mm	24 120 kg	50,0 kPa	2 990 mm
	700 mm	24 430 kg	43,1 kPa	3 090 mm
	800 mm	24 710 kg	38,2 kPa	3 190 mm
	900 mm	24 990 kg	34,3 kPa	3 290 mm
Triple grouser HD	600 mm	24 130 kg	50,0 kPa	2 990 mm
Rubber shoe	600 mm	24 400 kg	51,0 kPa	2 990 mm

- **ECR235CL** with **dozer blade**, 5,7 m boom, 2,9 m arm, 693 kg bucket, 6 150 kg counterweight

Description	Shoe width	Operating weight	Ground pressure	Overall width
Triple grouser	600 mm	25 500 kg	53,0 kPa	2 990 mm
	700 mm	25 800 kg	46,1 kPa	3 090 mm
	800 mm	26 120 kg	40,2 kPa	3 190 mm
Triple grouser HD	600 mm	25 510 kg	53,0 kPa	2 990 mm
Rubber shoe	600 mm	25 790 kg	53,0 kPa	2 990 mm

Max. permitted buckets

Note: 1. Bucket size based on ISO 7451, heaped material with a 1:1 angle of repose.

2. "Max. permitted sizes" are for reference only and are not necessarily available from the factory.

3. Bucket widths are less than bucket's tip radius.

- **ECR235CL** with **direct fit bucket**, 6 150 kg counterweight

Description	Max. bucket volume / weight	5,7 m boom	
		2,5 m arm	2,9 m arm
GP bucket 1,5 t/m ³	l / kg	1 300 / 1 100	1 225 / 1 000
GP bucket 1,8 t/m ³	l / kg	1 150 / 950	1 075 / 900

- **ECR235CL** with **quick fit bucket**, 6 150 kg counterweight

Description	Max. bucket volume / weight	5,7 m boom	
		2,5 m arm	2,9 m arm
GP bucket 1,5 t/m ³	l / kg	1 175 / 1 000	1 075 / 900
GP bucket 1,8 t/m ³	l / kg	1 025 / 850	950 / 800

Dimensions

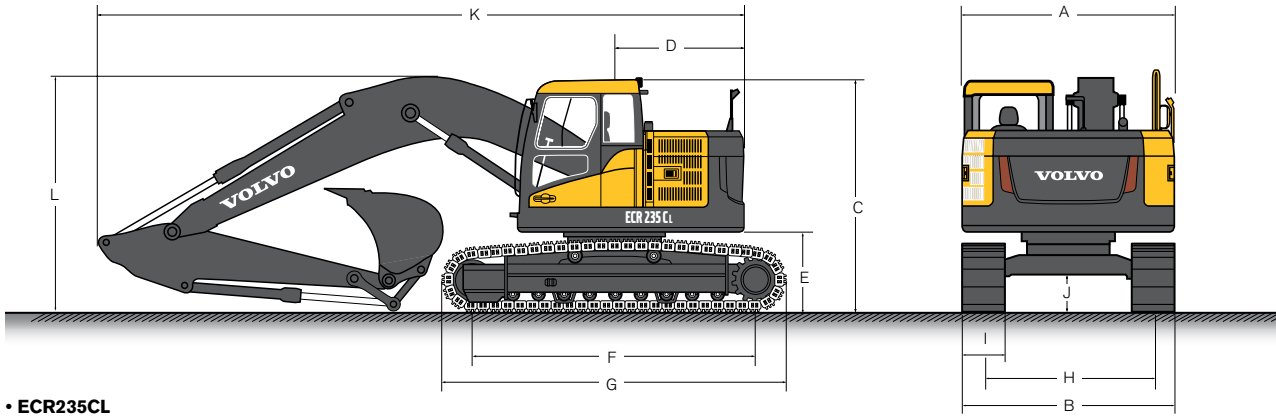

• ECR235CL

Description		5,7 m boom	
		2,5 m arm	2,9 m arm
A. Overall width of upper structure	mm	2 990	2 990
B. Overall width	mm	3 090	3 090
C. Overall height of cab	mm	3 040	3 040
D. Tail swing radius	mm	1 680	1 680
E. Counterweight clearance *	mm	1 025	1 025
F. Tumbler length	mm	3 660	3 660
G. Track length	mm	4 460	4 460
H. Track gauge	mm	2 390	2 390
I. Shoe width	mm	700	700
J. Min. ground clearance *	mm	460	460
K. Overall length	mm	9 080	8 985
L. Overall height of boom	mm	3 235	3 080

* Without shoe grouser

• Boom

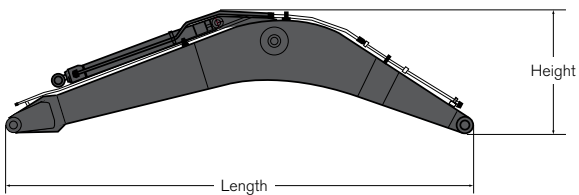

Description		5,7 m
Length	mm	5 910
Height	mm	1 770
Width	mm	670
Weight	kg	1 960

* Includes arm cylinder, piping and pin

• Arm

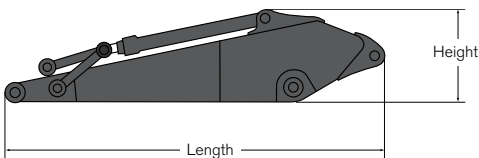

Description		2,5 m	2,9 m
Length	mm	3 520	3 910
Height	mm	860	860
Width	mm	440	440
Weight	kg	975	1 000

* Includes bucket cylinder, linkage and pin

• Front dozer blade

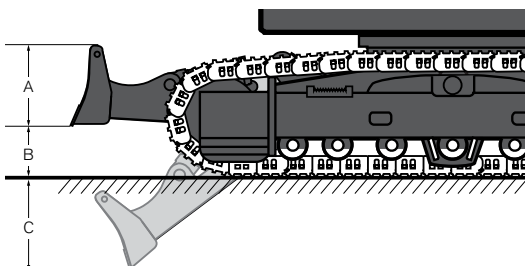

Description		Measurement
A. Height	mm	600
Width*	mm	2 990
Weight	kg	780
B. Lift height	mm	610
C. Digging depth	mm	480

* Matches shoe width; varies per shoe width selected

Working ranges & digging force

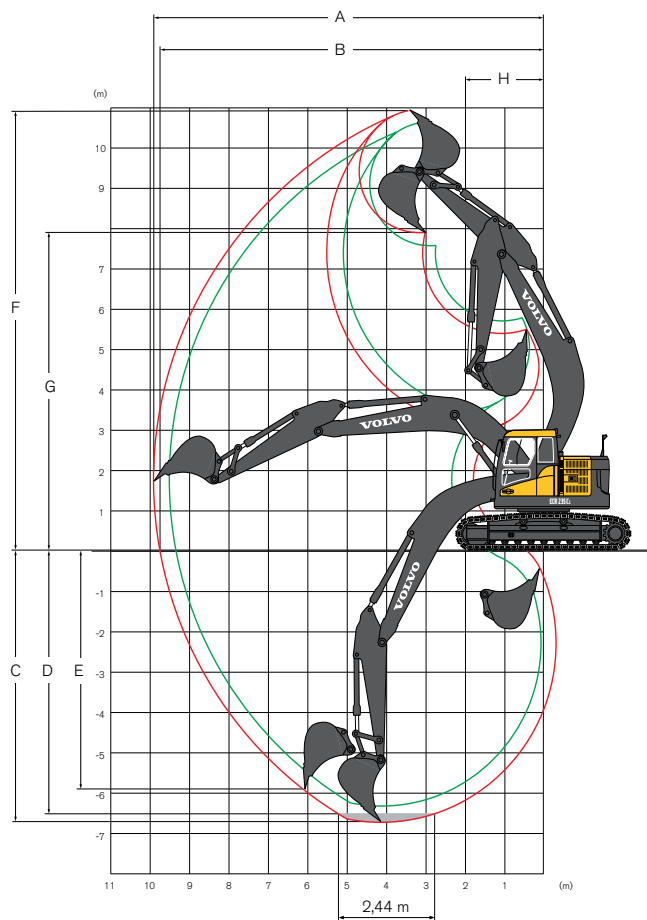

• ECR235CL

Machine with direct fit bucket		5,7 m boom	
		2,5 m arm	2,9 m arm
A. Max. digging reach	mm	9 505	9 885
B. Max. digging reach on ground	mm	9 340	9 725
C. Max. digging depth	mm	6 350	6 750
D. Max. digging depth (2,44 m level)	mm	6 120	6 550
E. Max. vertical wall digging depth	mm	5 105	5 725
F. Max. cutting height	mm	10 600	10 915
G. Max. dumping height	mm	7 570	7 880
H. Min. front swing radius	mm	2 280	2 000















Digging forces with direct fit bucket			5,7 m boom	
			2,5 m arm	2,9 m arm
Bucket radius	mm	1 530	1 530	
Breakout force - bucket (Normal/Power boost)	SAE J1179	kN	117,5 / 124,7	117,5 / 124,7
	ISO 6015	kN	133,1 / 141,2	133,1 / 141,2
Tearout force - arm (Normal/Power boost)	SAE J1179	kN	110,1 / 116,7	95,3 / 100,9
	ISO 6015	kN	114,4 / 121,3	97,8 / 103,7
Rotation angle, bucket	deg.	175	175	

Lifting capacity

At the arm end without bucket.

For lifting capacity including bucket, simply subtract actual weight of the direct fit bucket or the bucket with quick fit from the following values.

• ECR235CL

 Across undercarriage  Along undercarriage	Lifting hook related to ground level	1,5 m		3,0 m		4,5 m		6,0 m		7,5 m		Max. reach			
														Max. m	
Boom 5,7 m + Arm 2,5 m + Shoe 600 mm + Counterweight 6 150 kg	9,0 m kg												*8 000	*8 000	2,79
	7,5 m kg					*6 490	*6 490						*6 110	*6 110	5,32
	6 m kg					*6 670	*6 670	*6 400	5 030				*5 650	4 220	6,63
	4,5 m kg			*10 580	*10 580	*7 970	7 680	*6 860	4 880				5 560	3 440	7,42
	3 m kg					*9 970	7 100	7 650	4 640	5 380	3 300		5 000	3 070	7,85
	1,5 m kg					11 670	6 590	7 370	4 400	5 260	3 190		4 800	2 910	7,97
	0 m kg					11 350	6 320	7 180	4 230	5 170	3 110		4 880	2 940	7,80
	-1,5 m kg			*9 980	*9 980	11 280	6 260	7 100	4 160				5 320	3 190	7,32
	-3 m kg			*15 000	12 390	*11 010	6 330	7 150	4 210				6 430	3 820	6,46
-4,5 m kg			*11 310	*11 310	*8 310	6 570						*7 230	5 620	5,02	
Boom 5,7 m + Arm 2,9 m + Shoe 600 mm + Counterweight 6 150 kg	9,0 m kg												*5 240	*5 240	3,66
	7,5 m kg					*5 820	*5 820						*4 260	*4 260	5,82
	6 m kg					*6 080	*6 080	*5 970	5 130				*3 990	3 900	7,04
	4,5 m kg			*9 220	*9 220	*7 380	*7 380	*6 500	4 980	*5 140	3 460		*3 960	3 240	7,78
	3 m kg			*12 880	*12 880	*9 410	7 280	*7 420	4 730	5 440	3 360		*4 110	2 910	8,19
	1,5 m kg					*11 350	6 720	7 450	4 470	5 310	3 230		*4 430	2 770	8,30
	0 m kg			*5 730	*5 730	11 440	6 390	7 230	4 280	5 190	3 130		4 610	2 790	8,14
	-1,5 m kg	*6 170	*6 170	*9 930	*9 930	11 300	6 280	7 120	4 180	5 140	3 090		4 970	2 990	7,68
	-3 m kg	*10 540	*10 540	*15 550	12 310	11 340	6 310	7 130	4 190				5 860	3 500	6,87
-4,5 m kg			*12 790	12 650	*9 300	6 490						*7 250	4 830	5,54	
Boom 5,7 m + Arm 2,5 m + Shoe 600 mm + Counterweight 6 150 kg + Dozer blade	9,0 m kg												*8 000	8 000	2,79
	7,5 m kg					*6 490	*6 490						*6 110	*6 110	5,32
	6,0 m kg					*6 670	*6 670	*6 400	5 310				*5 650	4 470	6,63
	4,5 m kg			*10 580	*10 580	*7 970	*7 970	*6 860	5 170				*5 600	3 660	7,42
	3,0 m kg					*9 970	7 520	*7 720	4 930	5 900	3 520		5 490	3 270	7,85
	1,5 m kg					*11 730	7 000	8 080	4 690	5 780	3 410		5 280	3 110	7,97
	0 m kg					*12 450	6 740	7 880	4 510	5 690	3 320		5 380	3 150	7,80
	-1,5 m kg			*9 980	*9 980	*12 190	6 670	7 800	4 440				5 860	3 410	7,32
	-3,0 m kg			*15 000	13 170	*11 010	6 740	7 860	4 490				7 060	4 080	6,46
-4,5 m kg			*11 310	*11 310	*8 310	6 990						*7 230	5 980	5,02	
Boom 5,7 m + Arm 2,9 m + Shoe 600 mm + Counterweight 6 150 kg + Dozer blade	9,0 m kg												*5 240	*5 240	3,66
	7,5 m kg					*5 820	*5 820						*4 260	*4 260	5,82
	6 m kg					*6 080	*6 080	*5 970	5 410				*3 990	*3 990	7,04
	4,5 m kg			*9 220	*9 220	*7 380	*7 380	*6 500	5 260	*5 140	3 680		*3 960	3 450	7,78
	3 m kg			*12 880	*12 880	*9 410	7 690	*7 420	5 010	5 960	3 570		*4 110	3 100	8,19
	1,5 m kg					*11 350	7 140	8 150	4 750	5 820	3 450		*4 430	2 960	8,30
	0 m kg			*5 730	*5 730	*12 360	6 810	7 930	4 560	5 710	3 350		*5 000	2 980	8,14
	-1,5 m kg	*6 170	*6 170	*9 930	*9 930	*12 370	6 700	7 820	4 460	5 660	3 300		5 470	3 200	7,68
	-3 m kg	*10 540	*10 540	*15 550	13 090	*11 480	6 730	7 840	4 470				6 440	3 740	6,87
-4,5 m kg			*12 790	*12 790	*9 300	6 910						*7 250	5 150	5,54	

- Notes:
1. Machine in "Fine Mode-F" (Power Boost) for lifting capacities.
 2. The above loads are in compliance with SAE J1097 and ISO 10567 Hydraulic Excavator Lifting Capacity Standards.
 3. Rated loads do not exceed 87% of hydraulic lifting capacity or 75% of tipping load.
 4. Rated loads marked with an asterisk (*) are limited by hydraulic capacity rather than tipping load.

STANDARD EQUIPMENT

Engine

Turbocharged, 4-stroke diesel engine with water cooling, direct injection and charged air cooler that meets EU Stage IIIA requirements
Air filter with indicator
Air intake heater
Electric engine shut-off
Fuel filter and water separator
Fuel filler pump: 35 l/min, with automatic shut-off
Alternator, 80 A

Electric/Electronic control system

Contronics:

- Advanced mode control system
- Self-diagnostic system

Machine status indication

Engine speed sensing power control

Automatic idling system

One-touch power boost

Safety stop/start function

Adjustable LCD color monitor

Master electrical disconnect switch

Engine restart prevention circuit

High-capacity halogen lights:

- Frame-mounted 1
- Boom-mounted 2

Batteries, 2 x 12 V / 150 Ah

Start motor, 24 V / 5,5 kW

Hydraulic system

Hose rupture valve: boom

Overload warning device

Automatic sensing hydraulic system:

- Summation system
- Boom priority

- Arm priority
 - Swing priority
- Hydraulic piping:
- Hammer & shear: 1 pump flow
 - Quick coupler piping
 - Oil leak (drain) line, Base

Boom and arm regeneration valves

Swing anti-rebound valves

Boom and arm holding valves

Multi-stage filtering system

Boom cylinders

Cylinder cushioning

Cylinder contamination seals

Auxiliary hydraulic valve

Automatic two-speed travel motors

Long life hydraulic oil, ISO VG 46

Superstructure

Access way with handrail

Full height counterweight 6 150 kg

Tool storage area

Service walkway with anti-slip grating

Undercover (2,3 mm)

Rearview mirror

Cab and interior

Fabric seat with heater

Control joysticks with 4 switches each

Travel pedals with hand levers

Heater & air-conditioner, automatic

Hydraulic dampening cab mounts

Adjustable operator seat and joystick

control console

Antenna in-glass

Hydraulic safety lock lever

Cab, all-weather sound suppressed, includes:

- Ashtray
- Cup holder
- Lighter
- Door locks
- Floor mat
- Horn
- Large storage area
- Pull-up type front window
- Removable lower windshield
- Seat belt
- Safety glass, light tinted
- Rain shield
- Sun shield, front, roof, rear
- Windshield wiper with washer and intermittent feature

Anti-vandalism kit assembly preparation

Master key

Undercarriage

Hydraulic track adjusters

Greased and sealed track link

Track guard

Undercover (4,5 mm)

Standard roller guard

Track shoes

Track shoes, triple grouser

Digging equipment

Boom: 5,7 m

Arm: 2,9 m

Service

Tool kit, daily maintenance

OPTIONAL EQUIPMENT

Engine

Block heater: 240V

Diesel coolant heater, 5 kW, programmable

Water separator with heater

Electric

Extra lamps:

- Cab-mounted 2
- Upper structure-mounted 1

Anti-theft system

Rotating warning beacon

Travel alarm

Hydraulic system

Hose rupture valve: arm

Hydraulic piping:

- Hammer & shear: 2 pump flow
- Slope & rotator
- Oil leak (drain) line, boom
- Grapple

Volvo hydraulic quick fit, S1, U size

Long life hydraulic oil, ISO VG 32

Long life hydraulic oil, ISO VG 68

Hydraulic oil, biodegradable 32

Hydraulic oil, biodegradable 46

Boom float function

Pilot control pattern change

Cab and interior

Fabric seat

Fabric seat with heater and air suspension

Control joystick with proportional control

Falling object guard (FOG)

- Cab-mounted

Cab-mounted falling object

protective structure (FOPS)

Protective screen for front window

Anti-vandalism kit

Specific key

Rear-view camera

Straight travel pedal

Undercarriage

Full track guard

Dozer blade

Track shoes

Track shoes 500/600/700/800/900 mm, triple grouser

Rubber shoes, 600 mm

Digging equipment

Arm: 2,5 m

Service

CareTrack

Tool kit

Standard and optional equipment may vary by market. Please consult your local Volvo dealer for details.



Volvo Construction Equipment is different. Our machines are designed, built and supported in a different way. That difference comes from an engineering heritage of over 175 years. A heritage of thinking first about the people who actually use the machines. About how to help them be safer, more comfortable, more productive. About the environment we all share. The result of that thinking is a growing range of machines and a global support network dedicated to helping you do more. People around the world are proud to use Volvo. And we're proud of what makes Volvo different – **More care. Built in.**



Not all products are available in all markets. Under our policy of continuous improvement, we reserve the right to change specifications and design without prior notice. The illustrations do not necessarily show the standard version of the machine.

VOLVO

Volvo Construction Equipment
www.volvo.com

Ref. No. 21 A 100 3871 English (Global)
Printed in Sweden 2007.12-1,0 EXC
Volvo, Seoul