

B40D 6x6

**ARTICULATED
DUMP TRUCK
Mk VI**



Blu@dvantage™

Gross Power: 320 kW (429 hp)
Gross Torque: 2 100 Nm (1 549 lbft)
Rated Payload: 37 000 kg (81 571 lbs)

BELL

B40D 6x6 ARTICULATED DUMP TRUCK MkVI

ENGINE Mercedes Benz V6, turbocharged, intercooled, low emission diesel engine BlueTec[®] technology

Gross power 320 kW (429 hp) @ 1 800 rpm
 Net Power 310 kW (416 hp) @ 1 800 rpm
 Gross torque 2 100 Nm (1 549 lbf) @ 1 300 rpm
 Net torque 2 037 Nm (1 502 lbf) @ 1 300 rpm

Displacement 11,95 litres (730 cu.in)
 Fuel tank capacity 445 litres (118 US gal)
 Auxilliary Brake Automatic exhaust brake Engine Valve Brake (EVB)

AdBlue Tank Capacity 40 l (118 US gal)
 Certification Mercedes Benz BlueTec[®] OM 501 LA meets Europe (EU) stage 3b emissions regulations

TRANSMISSION Engine mounted, fully automatic Allison planetary transmission with six forward gears and one reverse gear. Hydrodynamic with lock-up in all gears.

Torque Converter 4500R ORS
 Model Electronic

TRANSFER BOX Remote mounted

Manufacturer VGR
 Model 17100
 Layout Three in-line helical gears.
 Output Differential Interaxle 33/67 proportional differential, Pneumatically lockable whilst stationary or on the move

AXLES High strength steel fabricated with spiral bevel type gears on the Controlled Traction differential and heavy duty outboard planetary gears.

Model Bell 25T

BRAKING SYSTEM

SERVICE BRAKES Dual circuit, full hydraulic actuation wet disc brakes on front and middle axles. 218 kN (49,010 lbf)
 PARK & EMERGENCY Spring applied, air released driveline mounted disc. 440 kN (98,920 lbf)
 AUXILLIARY BRAKE Automatic exhaust brake and Engine Valve Brake (EVB)



Maximum Retardation 447 kW (600 hp)
 Variable Adjustable Hydraulic Retarder

WHEELS Earthmover
 Tyre 29.5R25

FRONT SUSPENSION Semi-independent, leading A-frame supported by nitrogen/oil struts

REAR SUSPENSION Pivoting walking beams equalize the load on each axle with laminated suspension blocks. Each axle is coupled to the chassis by a Tri-Link system of four rubber-bushed links for ideal vertical movement and a transverse link for lateral restraint.

HYDRAULIC SYSTEM Variable displacement with load sensing system incorporating a ground driven emergency steering pump.
 Flow Pressure Filter 300 l/min (79,26 gal/min)
 25 Mpa (3,626 psi)
 5 micron

STEERING SYSTEM Hydrostatically actuated by two double acting cylinders, with ground-driven emergency steering pump.

Lock to lock turns 4.7
 Steering Angle +-42°

DUMPING SYSTEM Two double-acting, single stage, dump cylinders
 Raise Time 13 s
 Lowering Time 7,6 s
 Tipping Angle 70°

PNEUMATIC SYSTEM Air drier with heater and integral unloader valve, serving park brake and auxilliary functions
 System Pressure 810 kPa (117 psi)

ELECTRICAL SYSTEM
 Voltage 24 V
 Battery Type Two maintenance free permanently sealed
 Battery Capacity 2 X 105 Ah
 Alternator Rating 28 V 100 A

VEHICLE SPEEDS

1st	7,4	4.6
2nd	15,7	9.8
3rd	22,8	14.3
4th	34,8	21.8
5th	45,6	28.5
6th	52,0	32.5
R	6,3 km/h	3.9 mph



B40D 6x6 ARTICULATED DUMP TRUCK MkVI

LOAD CAPACITY & GROUND PRESSURE

WEIGHTS			GROUND PRESSURE			LOAD CAPACITY		
UNLADEN	kg	lbs	UNLADEN	kPa	psi	BODY	m³	cu.yd
Front	14,650	32,298	Front	232	14	Struck Capacity	18,5	24.2
Middle	7,810	17,218	Middle	238	7	SAE 2:1 Capacity	23	30
Rear	7,390	16,292	Rear	238	7	SAE 1:1 Capacity	27,5	36
Total	29,850	65,808	Total			SAE 2:1 Capacity with Autogate	24	31.4
LADEN			LADEN					
Front	19,587	43,182	Front	254	37			
Middle	23,842	52,563	Middle	316	46	Rated Payload	37,000 kg	81.571 lbs
Rear	23,422	51,637	Rear	314	46			
Total	66,851	147,381						

GRADEABILITY/RIMPULL

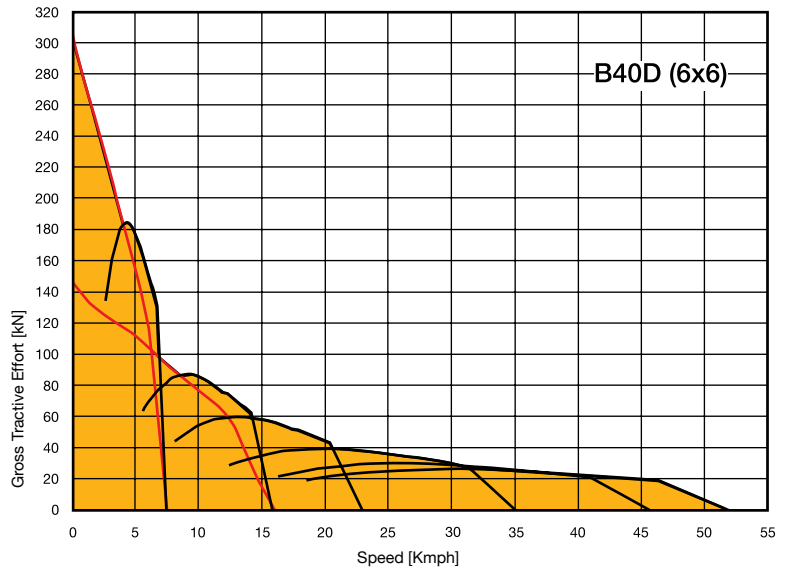
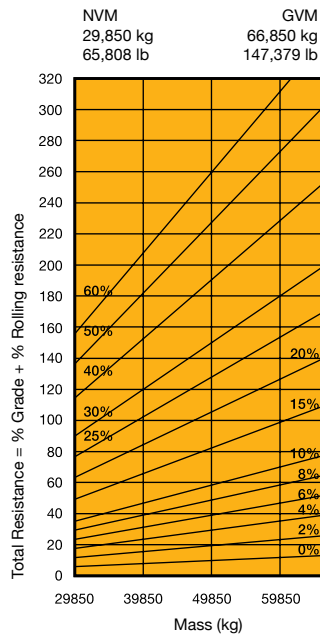

RETARDATION

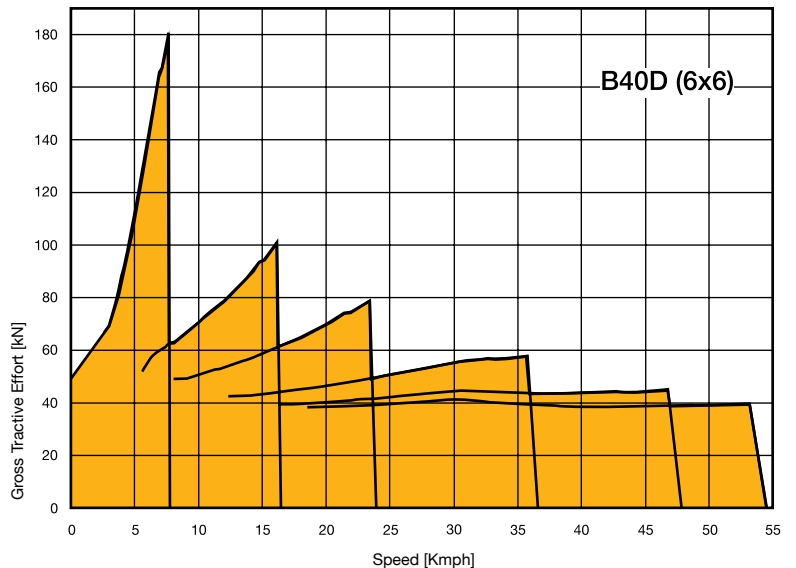
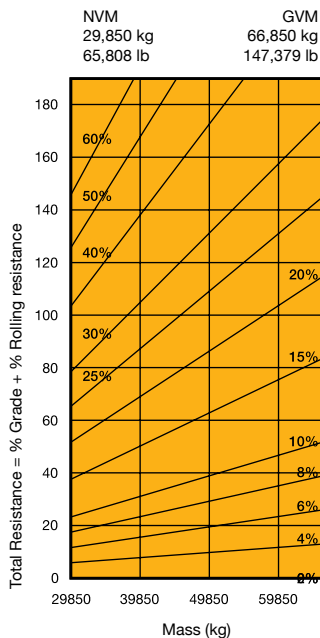

B40D 6x6 ARTICULATED DUMP TRUCK

MkVI

DIMENSIONS

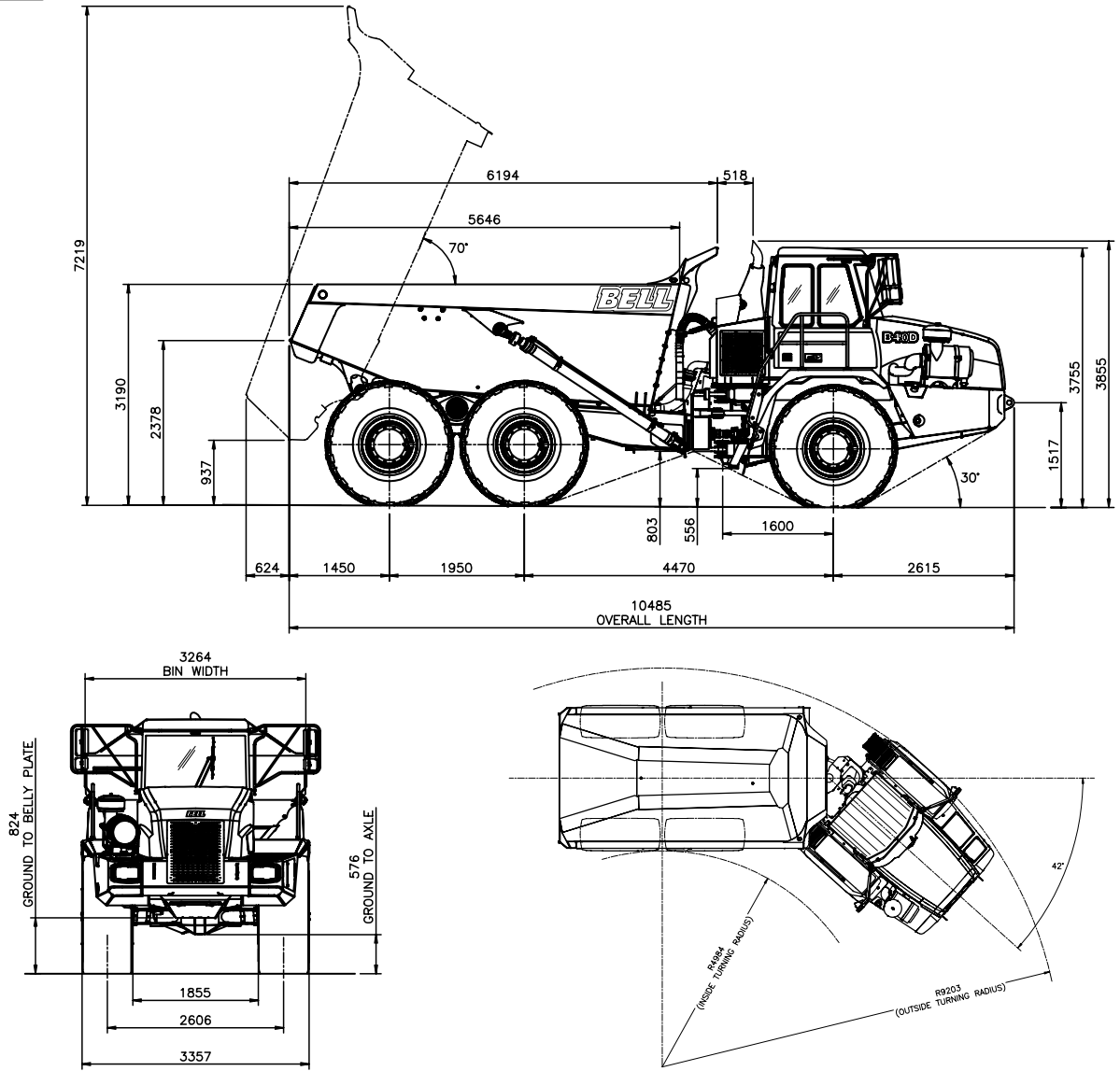

B40D 6x6 ARTICULATED DUMP TRUCK MkVI

AVAILABLE EQUIPMENT*

Cab

- ROPS/FOPS certification
- Protective rear window guard
- Tilt cab for service access
- Gas strut supported door
- Tinted safety glass
- Sliding windows
- Rear view mirrors- regular and wide angle
- Electrically adjustable rearview mirrors - one per side
- Sun visor
- Wiper/washer with intermittent control
- Tilt and telescoping steering wheel
- Adjustable, air suspension seat with retractable seat belt
- Fold-away trainer seat with retractable seat belt
- HVAC climate control system with filtered and ducted air
- Rotating beacon
- 12 V power outlet/12 V cigarette lighter
- Ash tray
- Drinks holder
- Cooled/heated lunch box
- I-Tip programmable bin tip
- Sound insulated to 76 dB(A) to ISO 6396
- Radio/CD/Tape
- Memory Module
- Air horn

MDU Features

- Operator / Site selected speed control
- Tipping counter
- Trip timer
- Trip distance
- On Board Weigh System (OBW)
- Transmission gear selection
- Fuel Consumption
- Diagnostics
- Intermittent wiper timing control
- Speedo calibration for alternative tyre sizes

Gauges

- Metric /Imperial unit selection
- Warning lights with audible buzzer

Vehicle

- Engine coolant temperature
 - Engine oil pressure
 - Transmission oil temperature
 - Fuel
 - Tachometer
 - Battery voltage
 - Hourmeter
 - Odometer
 - System air pressure
- Ground driven emergency steering
 - Bin safety prop
 - Articulation lock
 - Integral transmission output retarder with 6 settings

Other

- (Factory or field installed)
- Groeneveld auto greasing system
 - Retractable sun visor
 - Exhaust body heating
 - Autogate
 - Body liners
 - Fleetmatic Satellite Monitoring System
 - Driver ID and immobiliser
 - Forward working lights
 - Artic reverse light
 - Fuel heater
 - External windshield visor
 - Headlight protection grills
 - Rear window wiper
 - Antenna mounting bracket
 - System for reverse camera
 - Wiggins quick fuelling system
 - Comfort ride suspension system
 - Tyre pressure monitoring
 - Full handrail kit

*standard specification for machines may vary according to region



B40D 6x6 ARTICULATED DUMP TRUCK Mk VI

- The exclusive on-board weighing option presents the operator with real time information on the payload while the machine is being loaded. A 'limp home' mode can also be activated if the machine is significantly over-loaded.



- The park brake automatically applies when neutral is selected and it is not possible to engage neutral at speed. Torque dependent park brake release (hill assist) ensures no roll back on slopes.



- The incorporation of a Pitch and Roll sensor in the vehicle allows the bin to not be operated if the truck is in an unsafe position.



- Full hand-rails kit can be installed to provide even more safety when performing engine checks.



- Keyless start, driver identity, and access codes ensures no unauthorized operation of your equipment.



- Both operator or site selectable maximum speed control allows the vehicle to automatically de-accelerate and apply the retarder to prevent onsite speeding.



- Reverse cameras are available for factory or on site fitment ensuring full view when reversing.



- Optional Tyre pressure - monitoring System ensures that the operator has real time information on all tyres pressure and temperature conditions.



- The best in class retarder and engine braking automatically applies when the operator lifts his foot off the accelerator. Retarder aggressiveness can be simply adjusted on the sealed switch module ensuring maximum descent control for all conditions.

- All trucks can be set up to automatically sound the horn when starting or switching between forward and reverse.

CablePrice (NZ) Ltd
3 Tunnel Grove, Petone
Wellington, New Zealand

Phone: 0800 555 456

Email: sales@cableprice.co.nz | www.cableprice.co.nz

All dimensions are shown in millimetres, unless otherwise stated between brackets. Under our policy of continuous improvement, we reserve the right to change specifications and design without prior notice. Photographs featured in this brochure may include optional equipment.

BlueTec[®] is a registered trademark of Daimler AG
Blu@vantage[™] is a trademark of Bell Equipment Co. (PTY) Ltd

**Strong Reliable Machines
Strong Reliable Support**

BELL