

ARTICULATED DUMP TRUCK



Specifications

Maximum Payload	25 tonne (27.5 US Ton)
Heaped Capacity	15.5m ³ (20.3 yd ³)
Gross Power	272kW (365 hp)
PLI	A957 FEB 10

Features

- High powered, heavy-duty truck with powerful engine providing class leading performance and ability to go where others can't follow
- World class operator's environment
- One of the most fuel efficient trucks in the field
- Rigorously tested in extreme conditions for proven power, productivity and reliability
- Superior gradeability and higher top speeds increase production

WORKS FOR YOU.

SPECIFICATIONS

Engine

Engine	Cummins QSM11
Type	6 cylinder, in line, four cycle, direct injection diesel, water cooled, turbo charged with air to air charge cooling
Piston Displacement	10,8 litres (660 in ³)
Bore x Stroke	125 x 147 mm (4.92 x 5.97in)
Gross Power	272 kW (365 hp) @ 1800 rpm
Net Power	238 kW (319 hp) @ 2100 rpm
Maximum Torque	1 673 Nm (1 234 lbf ft) @ 1400 rpm
Gross Power rated	SAE J1995 Jun 90
Engine Emissions	Meets USA EPA Tier 3/CARB MOH 40 CFR 89 Tier 3 and proposed EUNRMM (non-road mobile machinery directive) stage 3
Electrical	24 volt electric start. 70A alternator. Two 12 volt 175 Ah batteries
Air Cleaner	Dry-type air cleaner with safety element, automatic dust ejector and restriction indicator
Fan	Modulating fan reduces noise level and consumes engine power as required. Note: Net hp with fan clutch disengaged
Altitude	Electronic derate 3 048 m (10 000 ft)

Transmission

Transmission	ZF 6WG 260 RPC Fully automatic with manual over-ride.
--------------	-------------------------------------------------------

Assembly
Consists of a torque converter close-coupled to a countershaft type gearbox with integral output transfer gearing. Automatic shifting throughout the range, with kick-down feature. Lockup in all forward gears. A torque-proportioning output differential transmits drive permanently to front and rear axles. This differential may be locked by the driver for use in difficult traction conditions.

Speeds km/h (mph)	Gear	Forward	Reverse
	1	5.5 (3.4)	5.5 (3.4)
	2	8.6 (5.4)	13.4 (8.4)
	3	13.4 (8.4)	30.7 (19.0)
	4	20.8 (12.9)	
	5	30.7 (19.0)	
	6	50.4 (31.3)	

Axles

Heavy duty axles with fully floating axle shafts and outboard planetary reduction gearing. The three axles are in permanent all-wheel drive (6x6) with a differential coupling between the front and rear axles. All three axles also have hydraulically actuated multiplate transverse diff-lock differentials for 100% cross-axle lock up. The inter-axle and cross-axle diff locks are controlled by the operator, and can be actuated when required in poor traction conditions.

Differential ratio	3.875 : 1
Planetary reduction	5.71 : 1
Overall Drivetrain reduction	22.12 : 1



Suspension

Front	Axle is carried on the leading arms of a sub-frame which pivots on the main frame.
Rear	Each axle is coupled to the frame by three rubber-bushed links with lateral restraint by a transverse link. Pivoting inter-axle balance beams equalise load on each rear axle. Suspension movement is cushioned by rubber/metal laminated compression units between each axle and underside of balance beam ends. Pivot points on leading and trailing links are rubber-bushed and maintenance-free.

Steering

Hydrostatic power steering by two double-acting cushioned steering cylinders with pressure supplied by a variable displacement / load sensing piston pump. An audible alarm and warning light indicates should the second system activate.

Steering angle to either side	45°
Lock to lock turns, steering wheel	4
System pressure	241 bar (3 500 lbf/in ²)
SAE Turning Radius	8 470 mm (27-9 ft/ins)
Clearing Radius	8 950 mm (29-4 ft/ins)

Frame

Front and rear frames are all-welded high grade steel fabrications with rectangular box-section beams forming the main side and cross members. Inter-frame oscillation is provided by a large diameter cylindrical coupling which houses nylon bushings. Frames articulated 45° to either side for steering by means of two widely-spaced pivot pins in back-to-back sealed taper roller bearings.

Body

All-welded construction, fabricated from high hardness (min 360 BHN) 1 000 Mpa (145 000 lbf/in²) yield strength steel. Dual slope tailchute improves material ejection from body.

Plate thickness:	Floor and tailchute	14.0 mm (0.55 in)
	Sides	12.0 mm (0.47 in)
	Front	8.0 mm (0.31 in)
Volume:	Struck	12.5 m ³ (16.4 yd ³)
	Heaped 2:1 (SAE)	14.5 m ³ (20.3 yd ³)

Hoist

Two single-stage, double-acting hoist cylinders, cushioned at the base end. Variable displacement / load sensing piston pump driven from power take-off on transmission. Full flow return line filtration. Full electro-hydraulic hoist control, with electronic detent in power down.

System pressure	220 bar (3 200 lbf/in ²)	Raise (loaded)	12 seconds
Pump output flow rate	4.9 liter/sec (77.6 gal/min)	Lower	7.5 seconds

SPECIFICATIONS

Tyres and Wheels

Tyres	Standard 23.5. Optional 750/65
Rims	Standard 25x19.50. For optional tyre, 25x22.00
Wheels	3-piece earthmover rims with 12 stud fixing

Brakes

All hydraulic braking systems with multiplate sealed and oil cooled brake packs at each wheel. Independent circuits for front and rear brake systems.

Parking	Spring-applied, hydraulic-released disc on rear driveline
Secondary	Secondary brake control actuates service and parking brakes
Retarder	Engine compression brake is standard.

Capacities

Fuel Tank	390 liters (103 gal)
Hydraulic System (Steering & Body)	202 liters (53.4 gal)
Engine Crankcase	41 liters (10.8 gal)
Cooling System	54 liters (14.3 gal)
Transmission (inc filters and cooler)	54 liters (14.3 gal)
Differential – Front & Rear (each)	21 liters (5.5 gal)
Differential - Centre	23 liters (6.0 gal)
Planetaries – (each)	7.5 liters (2.0 gal)

STANDARD EQUIPMENT

Cab and Operator

Air Conditioning	ROPS/FOPS Protection ISO 3471/3449 SAE J1040 Apr 88/J386
Air Filter Restriction Indicator	Seat Belts Retractable J386
Auxiliary power outlets 12V & 24V	Seat, Operator, air suspension, high back, headrest and adjustable armrests
CD/Tuner/MP3 Connectivity	Seat Passenger
Coat Hook	Steering Wheel, tilt/telescopic
Engine/Transmission/Hydraulic Diagnostic Facility	Storage Compartment
Heater and Demister	Sun Visor (Internal)
Insulation, Thermal and Acoustic	Tinted Glass
Interior Light	Transmission Visual Display Unit
Mirror Rear View (4)	Window Protection Grille, rear
Mug Holder	Wiper and Washer, front and rear windows
Reversing Safety camera/monitor	

Warning Lights & Audible Alarms

Alternator Charging	Front Brake Accumulator Pressure
Body Up	Headlight High Beam
Engine maintenance monitor	Transmission gear attained
Wait to start (not used)	Low Fuel
Differential lock	Parking Brake
Direction Indicators	Rear Brake Accumulator Pressure
Engine Air Filter Change	Secondary Steering
Engine Brake (not used)	Transmission check
Engine 'CHECK'	Transmission high oil temperature
Engine 'STOP'	Transmission Retarder (when option is fitted)

General

Articulation and Oscillation Lock	Modulating Cooling Fans
Battery Master Switch	Mudflaps at Front and Centre
Body Prop	Neutral Start Interlock
Brakes Fully Hydraulic Dual Circuit System	Pivot Protection Guard
Diagnostic Pressure Test Points	Rear Light Guards
Inter axle and Cross axle Differential Locks	Reverse Alarm Audible J994
Electronic Assisted Body Hoist Control	Secondary Steering
Engine/Transmission/Hydraulic electronic management systems	Security Kit
Engine Underguard	Tilting Cab for Maintenance
Exhaust Muffler	Tow Points, Front and Rear
Handrails on Fenders	Transmission Downshift Inhibitor
Headlamp Guards	Transmission Sump Guard
Horn, Electric 117db	Tyre Inflation Nitrogen
Hydraulic Filter Restriction Indicator	2 stage manual/automatic Engine Brake

Gauges

Transmission Sump oil Temperature	Speedometer/Digital Odometer/Tripmeter
Engine Coolant Temperature	System Voltage
Fuel Level	Tachometer
Hourmeter	Transmission Converter Oil Temp.

Lights

Direction and Hazard Warning Indicators (LED on rear)	Side and Tail (LED)
Front Working Lights, Roof Mounted	2 halogen headlamps dipped beam
Reverse Warning	2 halogen headlamps main beam

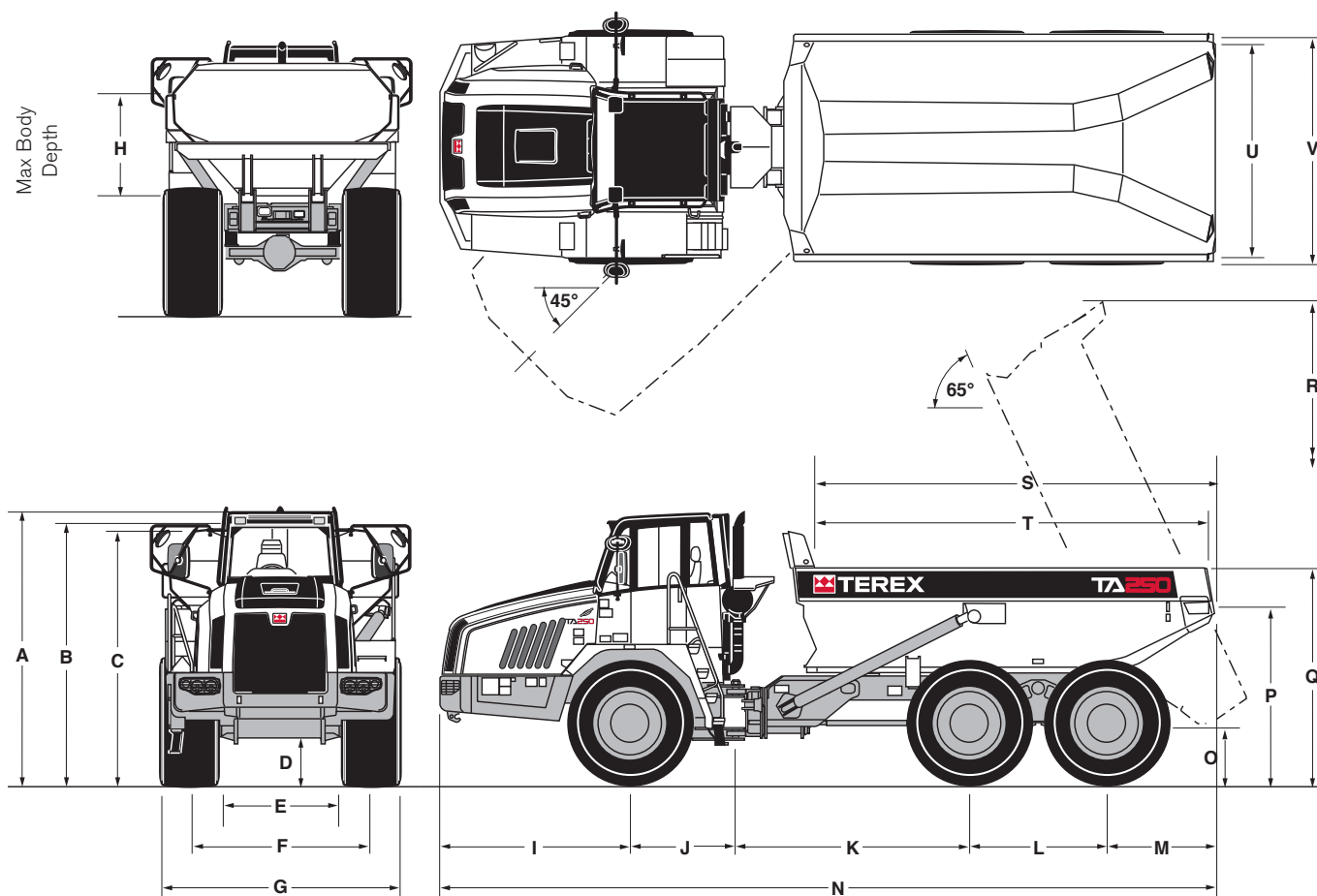

Weights

Net Distribution

Vehicle, Net	22 205 kg (48 953 lb)	Payload	25 000 kg (55 115 lb)
Bogie Axle		Bogie Axle	
Leading	5 205 kg (11 451 lb)	Trailing	5 276 kg (11 709 lb)
Front Axle	11 724 kg (25 793 lb)		

Gross Distribution

Vehicle Gross	47 205 kg (104 068 lb)	Body	4 100 kg (9 040 lb)
Front Axle	15 880 kg (34 936 lb)	Hoists, pair	530 kg (1 170 lb)
Bogie Axle	15 592 kg (34 302 lb)	Bare Chassis	17 335 kg (38 213 lb)

Ground Pressure

These figures are at 15% shrinkage of unloaded radius and specified weights using

Tires 23.5 R25

Unloaded

Front	118 kPa	17.1 Psi
Rear	53 kPa	7.6 Psi

Loaded

Front	161 kPa	22.3 Psi
Rear	158 kPa	22.9 Psi

Dimensions

Standard Unit	mm	ft-in
A	3 450	11-3
B	3 420	11-2
C	3 120	10-3
D	405	1-6
E	1 580	5-3
F	2 200	7-2
G	2 895	9-6
H	1 240	4-1
I	2 400	7-9
J	1 310	4-4
K	2 945	9-8
L	1 690	5-6
M	1 410	4-9
N	9 755	32-0
O	725	2-3
P	2 175	7-2
Q	2 740	8-11
R	6 015	19-9
S	5 000	16-5
T	4 930	16-2
U	2 685	8-10
V	2 895	9-6

Gradeability

Unit equipped with 23.5 R25 tires. Graphs based on 2% Rolling Resistance.

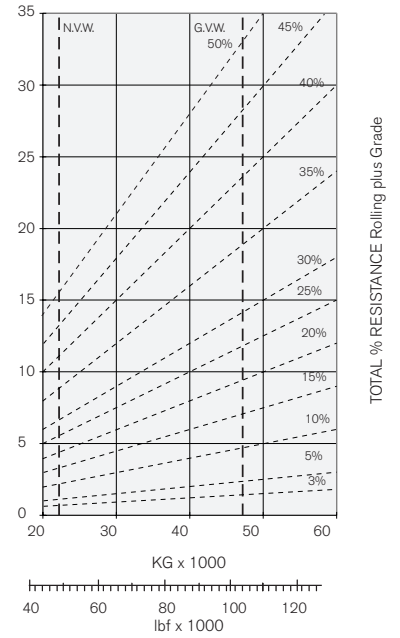
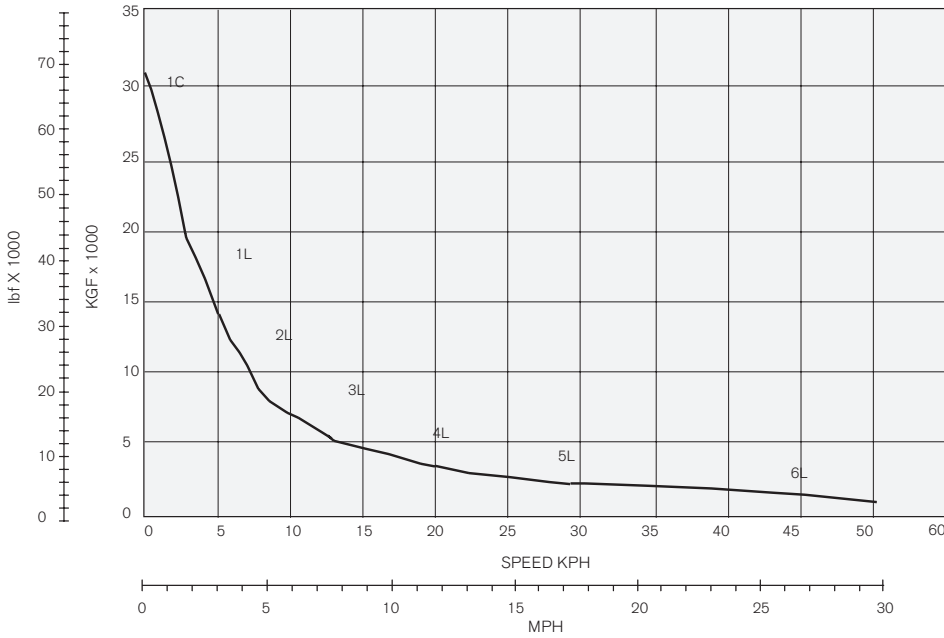

Retardation

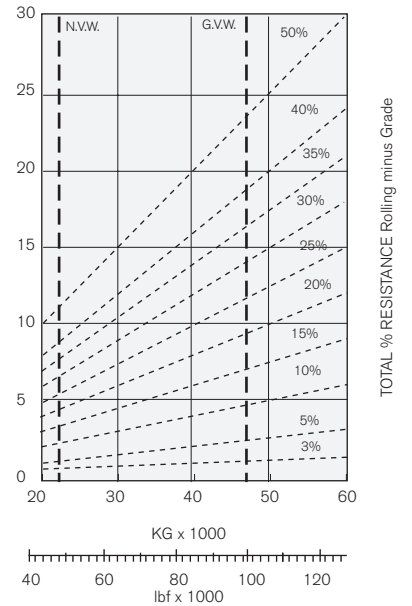
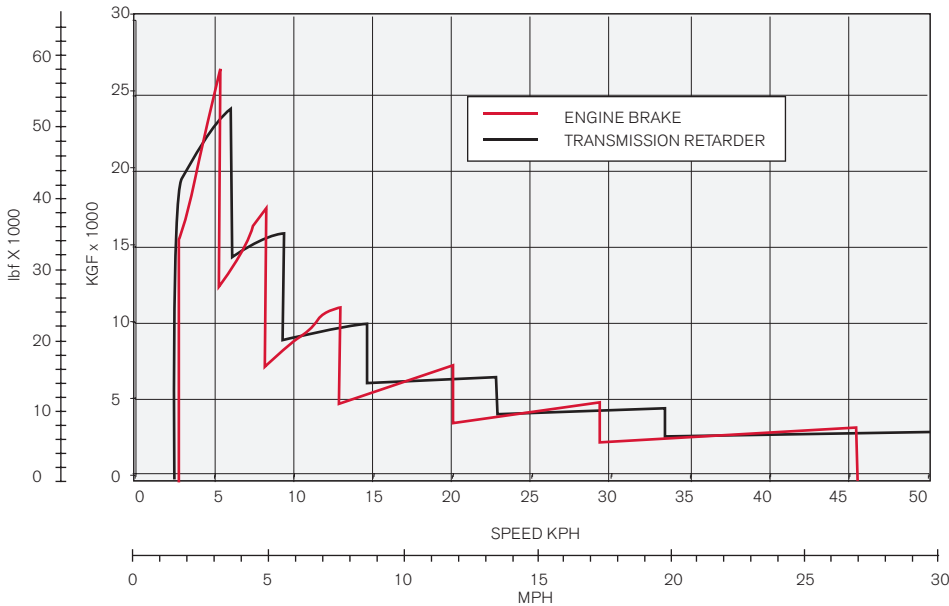

Instructions: From intersection of vehicle weight with percentage resistance line read across to determine maximum gear attainable, and then downwards for speed.

OPTIONAL EQUIPMENT

Body Options

Body Side Extensions	Spillguard Extension
Heated Body	Top Tailgate
Liner Plates	

Lights

Beacon Flashing	Rear Working Lights, Roof Mounted
Fog Rear	Reverse Flashing

Mirrors

Mirror Front Mounted	Mirrors Heated
Mirror with Wide Angle	

Other Options

Automatic Lubrication	Payload Monitoring System
Fire Extinguisher	Seat Heated
First Aid Kit	Transmission Retarder
Independent Suspension	Tool Kit
Parking Brake Guard	Hydraulic Oil Cooler

terex.com

Effective Date: January 2010. Product specifications and prices are subject to change without notice or obligation. The photographs and/or drawings in this document are for illustrative purposes only. Refer to the appropriate Operator's Manual for instructions on the proper use of this equipment. Failure to follow the appropriate Operator's Manual when using our equipment or to otherwise act irresponsibly may result in serious injury or death. The only warranty applicable to our equipment is the standard written warranty applicable to the particular product and sale and Terex makes no other warranty, express or implied. Products and services listed may be trademarks, service marks, or trade names of Terex Corporation and/or its subsidiaries in the USA and other countries. All rights are reserved. Terex is a registered trademark of Terex Corporation in the USA and many other countries. © 2010 Terex Corporation. Ref.-No.: TEREX622UK

Terex Equipment Ltd
Newhouse Industrial Estate, Motherwell, ML1 5RY
Tel: +44 (0) 1698 732121 Fax : +44 (0) 1698 734046
Email enquiries@terexce.com www.terex.co.uk



WORKS FOR YOU.