

- **Engine** Iveco Cursor 10 **TIER 3**
- **Power** 235 kW (319 HP)
- **Transmission** Automatic
- **G.V.W.** 45.440 kg
- **Payload** 23.200 kg (25 Sht)
- **Body heaped (SAE 2:1)** 14,5 m³

ADT 25C

Articulated Dumper 6x6

ENGLISH
03-2007



ENGINE

6-cylinder in-line Diesel cycle, electronically-controlled direct injection, pump injectors, turbocharger with intercooler, variable geometry turbine. Emissions – EPA – CARB / OFF ROAD TIER 3

Make and type: IVECO CURSOR 10, Tier 3 certified
 Bore x stroke: 125x140 mm(4.92"x5.51 in)
 Total displacement: 10300 cm³
 Max power: 235 kW (319 HP) @ 2100 rpm
 Max torque: 1450Nm (148 kgm) @ 1000 rpm
 Air filter: dry, with double cartridge
 Integrated engine brake: Iveco Turbo Brake
 Cold start - 25° C



PERFORMANCE

With standard 23,5R25 tyres

gear	gear ratio	speed (km/h)
1°	5,350	5,4
2°	3,446	8,4
3°	2,206	13,2
4°	1,421	20,5
5°	0,969	30,0
6°	0,624	46,6
1°RM	5,350	5,4
2°RM	2,206	13,2
3°RM	0,969	30,0



TRANSMISSION

Automatic ergopower ZF 6WG260 drive transmission with 6 gears forward and 3 reverse.

Hydraulic torque converter, multiplication ratio(stall torque): 1:2,08
 Lock-up clutch in all gears.

Return box with epicycloidal differential incorporated (torque's distribution deviceripartitore) which can be locked from the steering place.

Torque to front axle: 33,3%
 Torque to rear axles: 66,7%

Optional:

Integrated hydrodynamic retarder.

ECO (energy saving) and POWER (performance boosting) selectable modes.

Front integrated self-locking differential.



AXLES

Permanent 6x6 drive configuration, 2nd and 3rd axle Kessler D81.

Double reduction: central with bevel gear and epicycloidal gears in wheel hubs. Floating front axle with epicycloidal gears in wheel hubs (1:6) and differential built-in gearbox.

Central reduction ratio: 1:3,5
 Final reduction ratio: 1:6
 Total reduction ratio: 1:21



TYRES

Interchangeable wheels with steel web 19.5/2,5" (n°6)

Tubeless tyres 23.5 R 25 Michelin XADN

Optional: Good Year / Bridgestone 23,5 R 25
 Michelin 650/65 R 25 XAD 65
 Michelin/Bridgestone 750/65 R 25



STEERING

Complies with ISO 5010, SAE J53

Hydrostatic steering (orbitrol) with hydraulic amplifier

integrated with two double-acting cylinders with double effect operating on an articulated joint between the frames.

Centralized hydraulic pump: with gears
 flow @ 2100rpm: 248 l/min

max.operating pressure: 185 bar (18,5 Mpa)
 flow @ 1000 rpm: 32 l/min

max.operating pressure: 120 bar (12 Mpa)

Adjustable Steering column/steering wheel

Adjustable steering angle: ±45°



BRAKES

Independent circuit complies with ISO 3450 e SAE J 1473.

Dry disk on each wheel with mono heavy-duty caliper. Hydraulic control powered by self-limited gear pump and pressure's accumulators.

Service brake: two independent circuits (front/rear)

Emergency brake: incorporated in the service brake

Parking brake: pneumatic disc brake on the propeller shaft.

Iveco Engine Brake: Standard. Operator selectable application together with service brakes or when accelerator pedal is released (Exclusive Astra System). Electronic integrated management of Iveco Engine Brake and hydraulic retarder (OPT).

Optional: integrated hydrodynamic retarder, calipers protection.

integrated motor's brake max.braking power:

@ 2100 r/min 353 kW

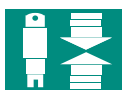

SUSPENSIONS

Front: semi-independent, "A" mount with PANHARD crossbar Hydro-pneumatic suspension cylinders (oil-nitrogen).

Rear: semi-independent rocker type, connected to axles by flexible joints with central reaction bars on axles.

Optional: front suspension inflation kit.



ELECTRICAL SYSTEM

Two batteries: 12 V / 170 Ah

Voltage: 24 V

Alternator: 90 A

Starter motor: 5 kW

All wires are number coded, protected by sheaths and fastened to the chassis. CAN bus Multiplex system which allows the communication between motor's central system, change and Body Computer. Dash with multifunctional integrated graphic display.



CHASSIS

Both front and rear chassis are made of high strength steel (ST 52.3) extruded (non-welded) rectangular tubular side members and linked by bracing crossmembers.

Chassis joined by fifth-wheel type articulated joint with double ball crown and double lip seal ball joints



HYDRAULIC SYSTEM

The steering system's circuit and the overturning system are powered by a gear pump flanged to the gear and integrated with a cooled distributor.



GREASING SYSTEM

The 23 subject-to-wear-points are connected through a grease system.

Optional: centralized automatic greasing system which can be programmed, with lubricant's level gauge in the cab.



BODY

Walls and bottom in high abrasion strength steel (360-440 HB).

Elastic pads between body and chassis.

Bottom thickness..... 15 mm 0.590 in.

Front panel thickness 8 mm 0.315 in.

Side walls thickness 12 mm 0.472 in.

Lifting by two double-acting hydraulic cylinders, installed inside chassis members.

Tipping angle: 68°

Tipping time:

Rising 13"

Lowering 13"

Capacity:

struck 10,6 m³ 13,9 yd³

heaped (SAE 2:1) 14,5 m³ 18,9 yd³

Optional: Reinforced rock body; extra body side walls; body heater; tailgate; automatic body tipper control system



EQUIPMENT

The equipment and the fittings depend on the requirements and laws of the different markets. The prices of the standard equipments and of the optional fittings are given in the local price lists



WEIGHT Kg

	Kg TARE (*)		Kg PAYLOAD		Kg TOTAL WEIGHT	
	Kg	lb	Kg	lb	Kg	lb
Front axle	12.155	26.797	3.165	6.977	15.320	33.774
Rear axles (tandem)	10.085	222.233	20.035	44.169	30.120	66.403
Total	22.240	49.030	23.200	51.147	45.440	100.177

* Ttare includes fuel, lubricants and driver (70 kg)



CAB

Complies with ROPS SAE J1040, ISO 3471/FOPS SAE J231, ISO 3449 Stainless steel, soundproofed and centrally mounted, suspended through oil-rubber bumpers.

Central driver's seat with universal adjustment and pneumatic suspension. Motor's bonnet with electrical overturning.

Athermic glasses.

Side mudguards with gullwing action.

Operating instrumentation and accessories .

Overturn on LEFT-side to facilitate the operations of extraordinary maintenance.

Automatic climate control with pollen filter.

Door with glazing in the lower part to give maximum visibility.

Instructor's seat.

Windscreen sun screen.

Sound advisor reverse gear.

Optional: RDS radio, yellow rotary light, refrigerator, sound advisor reverse gear, reverse gear videocamera, Side window wipers, GPS, fire-extinguisher.



INSTRUMENTS

Onboard computer for managing all vehicle operational data (levels, overheat warning lights, unit anomalies, etc.).

External level gauges on fuel, hydraulic oil and brake cooling oil tanks

Optional: Electronically controlled transmission and brake oil warm-up system for quick start-up in cold weather. Trip computer. Patent-pending exclusive ASTRA system.



FLUID CAPACITIES

Refer to the use and maintenance manual for fluids specifications.

Engine oil and filters 30,5 l 80.05 US Gals

Transmission and filters 41 l 10.03 US Gals

Cooling system..... 37 l 9.77 US Gals

Front differential 14 l 3.70 US Gals

Intermediate axle 35 l 9.25 US Gals

Rear axle 33 l 8.71 US Gals

Oil hub (each) 3 l 0.79 US Gals

Hydraulic tank 210 l 55.48 US Gals

Fuel tank 380 l 100.3 US Gals

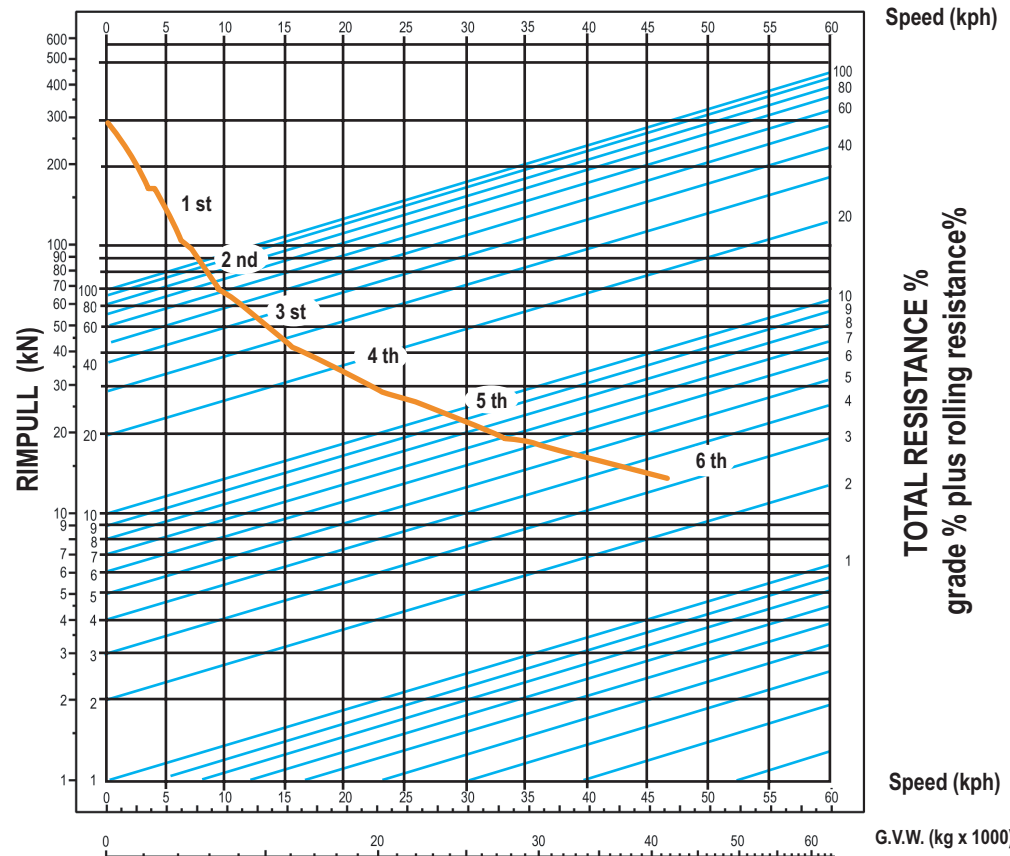

From the meeting between the M.T.T. of the vehicle and the inclined line corresponding to the total resistance %, to the left to determine the corresponding gear and, coming down, the max. speed of the vehicle.

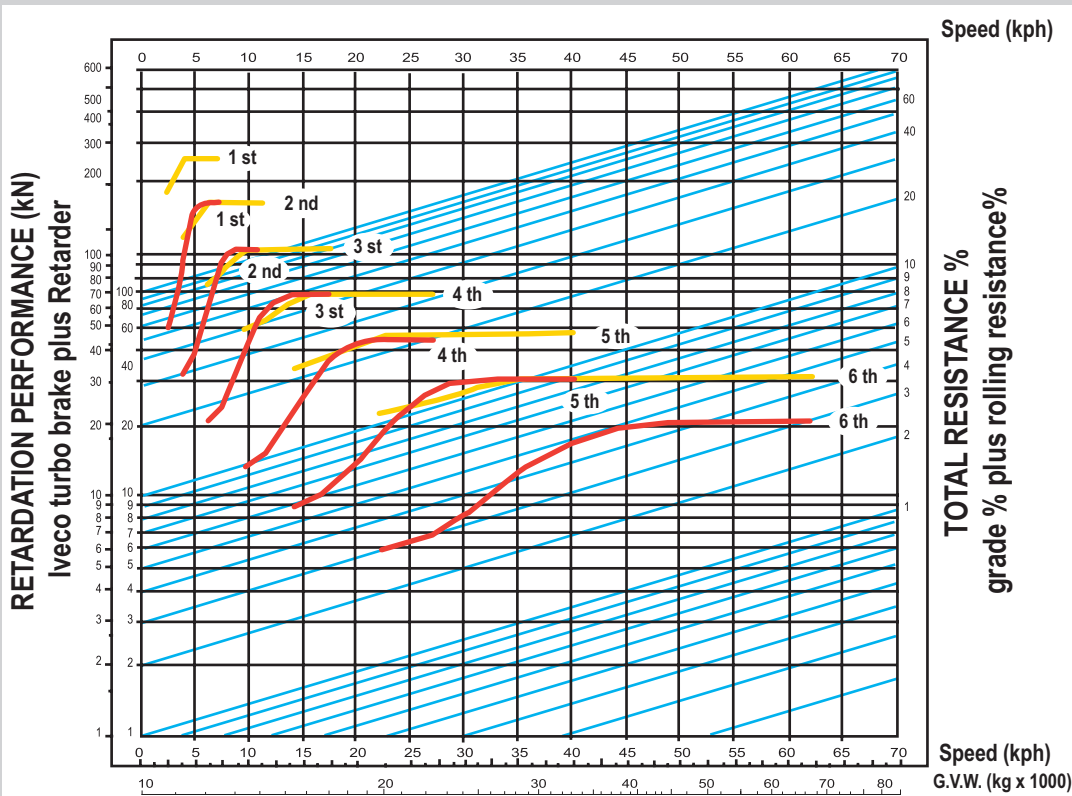

The curves in red refer to the motor's brake (STD); those in yellow, to the motor's brake plus retarder (OPT).

ROLL RESISTANCE		
Road surface Features	for each t G.V.W.	%
Black top-concrete	15kg	1,5%
Hard packed soil	20kg	2,0%
Excavated not compact	30kg	3,0%
Mud on packed soil	40kg	4,0%
Packed snow	25kg	2,5%
Soft snow	45kg	4,5%
Sand-gravel	100kg	10,0%

Articulated Dumper ADT 25C

Dimensions in mm

Tubeless Tyres Michelin 23,5R25

Loaded : front 15.320 Kg, rear 30.120 Kg

*Unloaded : front 12.155 Kg, rear 10.085 Kg

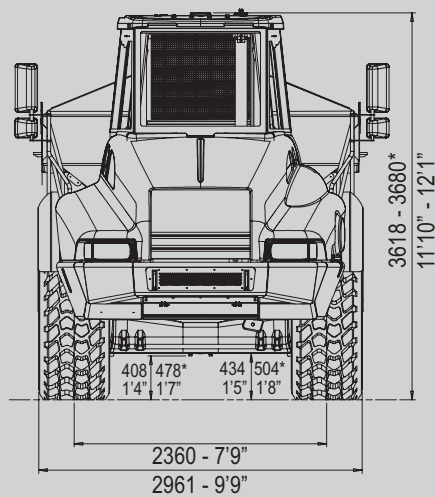
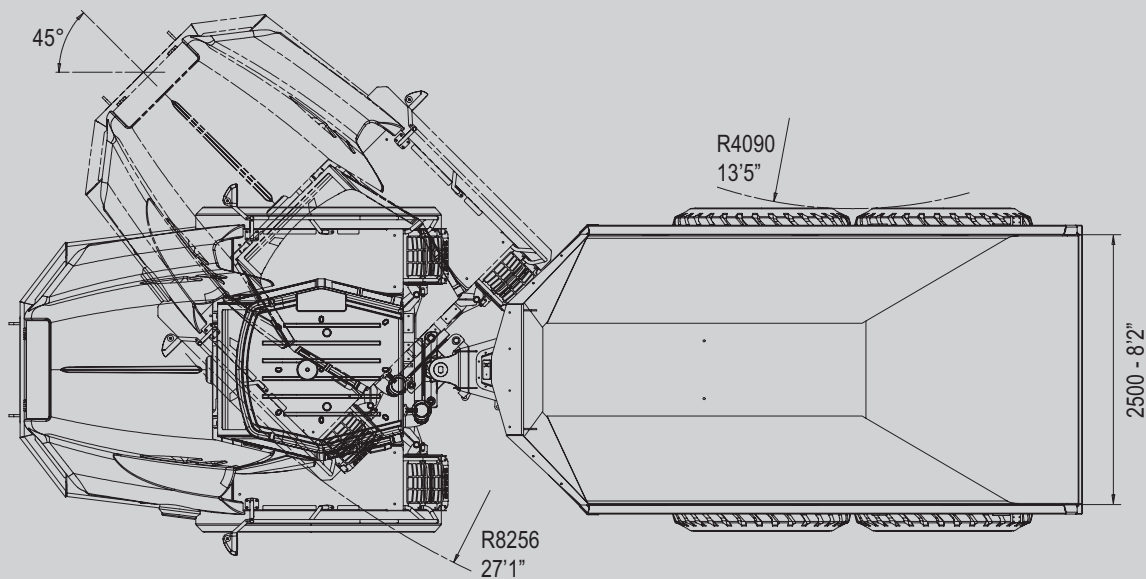
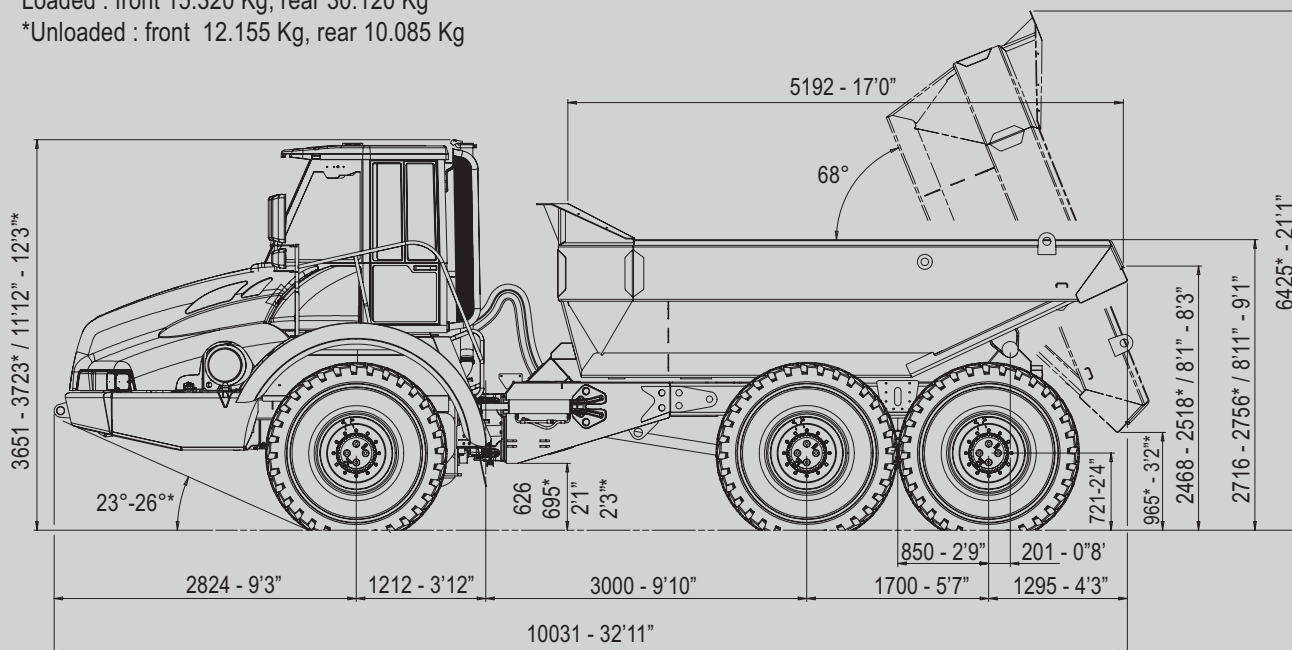



Articulated Dumper **ADT 25C**



Features and equipment subject to change without notice

25 M.K.T.- 03.07- A3500899

ASTRA Veicoli Industriali S.p.A.
Via Caorsana, 79
29100 Piacenza (Italy)
Tel. ++39-523.5431
Fax ++39 523.591773
www.astraspa.com

DEALER