

- Engine *Iveco Cursor 10*
- Power *235 kW (319 HP)*
- G.V.W. *45.440 kg*
- Payload *23.200 kg (25 Sht)*
- Body heaped(SAE 2:1) *14,5 m³*

Articulated Dumper 6x6 ADT 25D



ENGINE

6 in-line cylinder Diesel cycle, electronically controlled direct injection, pump injectors, variable geometry turbocharger with intercooler.

Emissions: EPA - CARB - OFF ROAD TIER 3
 Make and type: IVECO CURSOR 10, Tier 3
 Bore x stroke: 125x140 mm(4.92"x5.51 in)
 Total displacement: 10300 cm³
 Max power: 235 kW (319 HP) @ 2100 rpm
 Max torque: 1450Nm (148 kgm) @ 1000 rpm
 Air filter: dry, with double cartridge
 Integrated engine brake: Iveco Turbo Brake
 Cold start - 25° C



PERFORMANCE

With standard 23,5R25 tyres

gear	gear ratio	speed (km/h)
1°	5,350	5,4
2°	3,446	8,4
3°	2,206	13,2
4°	1,421	20,5
5°	0,969	30,0
6°	0,624	46,6
1°RM	5,350	5,4
2°RM	2,206	13,2
3°RM	0,969	30,0



TRANSMISSION

Automatic ergopower ZF 6WG260 transmission with 6 gears forward and 3 reverse.

ECO (energy saving) and POWER (performance boosting) selectable modes.

Hydraulic torque converter, stall torque ratio: 1:2,08

Automatic lock-up in all gears.

Integrated and lockable transfer box.

Torque to front axle: 33,3%

Torque to rear axles: 66,7%



AXLES

Permanent 6x6 drive configuration, Kessler D81 axles.

Double reduction: central by bevel gear and final by planetary gears in wheel hubs.

New rigid front axle.

Central reduction ratio: 1:3,5

Final reduction ratio: 1:6

Total reduction ratio: 1:21



TYRES

Rim:19.5/2,5" (n°6)

Tyres: 23.5 R 25 Triangle TB 516

Optional: Michelin 23.5 R 25 XADN
 Michelin 650/65 R 25 XAD 65



STEERING

Complies with ISO 5010, SAE J53.

Hydraulic steering (ORBITROL) with flow amplifier integrated by two double-acting cylinders operating on the articulating hitch.

Centralized hydraulic pump: with gears

flow @ 2100rpm: 248 l/min

max.operating pressure: 185 bar (18,5 Mpa)

flow @ 1000 rpm: 32 l/min

max.operating pressure: 120 bar (12 Mpa)

Adjustable steering column/steering wheel

Steering angle: ±45°



BRAKES

New independent pneumo-hydraulic circuits in compliance with ISO 3450 and SAE J 1473.

Dry disk brakes with single caliper on front axle and double caliper on intermediate axle.

Pneumatic control fed by air compressor and pressure accumulators, hydraulic activation through converters.

Service brake: two independent circuits (front/rear)

Emergency brake: integrated in service brake

Parking brake: ... pneumatic disc brake on the rear tandem.

Integrated engine brake:

Max. braking force 353 kW@ 2100 r/min

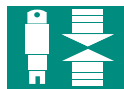

SUSPENSIONS

Front: semi-independent, with "A" frame, a PANHARD bar. Hydro-pneumatic suspension cylinders (oil-nitrogen).

Rear: semi-independent rocker type, connected to axles by flexible joints and integrated with central reaction bars on axles.

Optional: front suspension inflation kit.



ELECTRICAL SYSTEM

Two batteries: 12 V / 170 Ah

Voltage: 24 V

Alternator: 90 A

Starter: 5 kW

All wires are coded, covered and fastened to the chassis.

CAN bus Simple-Mux system allowing the communication between engine control unit (ECU), gearbox and Body Computer.

New cluster with high definition multifunctional color display.

New Black Box able to manage 140 records for each memory area.

Optional: Rear view camera with cluster integrated display.



CHASSIS

Front and rear chassis made in high strength steel (ST 52.3) with extruded (non-welded) rectangular side members linked by bracing crossmembers.

Oscillating hitch: two rows ball bearing with double lip sealing.



HYDRAULIC SYSTEM

The steering and the tipping systems are powered by a gear pump flanged to the gearbox and connected with a centralized distributor.



GREASING SYSTEM

Centralized greasing system.

Optional: programmable automatic greasing system, with grease level gauge in the cab.



BODY

Walls and bottom in abrasion resistant steel (Hardox 400). Elastic pads between body and chassis.

Bottom thickness..... 15 mm 0.590 in.

Front wall thickness 8 mm 0.315 in.

Side walls thickness 12 mm 0.472 in.

Lifting by two double-acting hydraulic cylinders, installed inside chassis members.

Tipping angle: 68°

Tipping time:

Rising 13"

Lowering 13"

Capacity:

struck 10,6 m³ 13,9 yd³

heaped (SAE 2:1) 14,5 m³ 18,9 yd³

Automatic body tipping control system.

Optional: Reinforced “semi-rock” body; body side extensions; body heating kit; rear tailgate; body front spillguard; “Extra Heavy Duty” body for extreme applications.



EQUIPMENT

The standard equipment and the optional fittings depend on the requirements and laws of the different markets.



WEIGHT Kg

	Kg TARE (*)		Kg PAYLOAD		Kg TOTAL WEIGHT	
	Kg	lb	Kg	lb	Kg	lb
Front axle	12.155	26.797	3.165	6.977	15.320	33.774
Rear axles (tandem)	10.085	222.233	20.035	44.169	30.120	66.403
Total	22.240	49.030	23.200	51.147	45.440	100.177

*Tare includes fuel, lubricants and driver (75 kg)



CAB

Complies with ROPS SAE J1040, ISO 3471/FOPS SAE J231, ISO 3449. Stainless steel, soundproof and centrally installed, suspended through oil-rubber pads.

Fully adjustable air suspension driver seat with safety belts. Hydraulic engine hood and cab tipping.

Athermic glasses.

Side mudguards with gullwing opening.

Cab tilting on the LEFT-side to facilitate extraordinary maintenance activities.

Automatic climate control with anti-pollen filter.

Door with glazing in lower part to offer maximum visibility.

Instructor seat with belt.

Windscreen sun visor.

Reverse gear buzzer.

Optional: RDS radio, yellow rotating beacon, work lights on top of the cab, refrigerator, rear view camera, rear view mirrors heated and remotely, controlled, side window wipers, electric engine hood tilting, fire-extinguisher.



INSTRUMENTS PANEL

On-board computer with digital/analogic instrumentation and performance/fault messages to manage all vehicle operating information (levels, warning lights, etc.).

Advanced vehicle diagnostic system: management and storage of engine, transmission, steering system, brakes, body tipping and pneumatic system data.

Connection for data download and analysis.

External level gauges for hydraulic oil and fuel.

Trip computer for vehicle productivity analysis



FLUID CAPACITIES

Refer to the use and maintenance manual for fluids specifications.

Engine oil and filters30,5 l80.05US Gals

Transmission oil and filters41 l10.03 US Gals

Cooling system 37 l 9.77 US Gals

Front axle 35 l 9.25 US Gals

Intermediate axle 35 l 9.25 US Gals

Rear axle 33 l 8.71 US Gals

Hydraulic tank 210 l 55.48 US Gals

Fuel tank 380 l 100.3 US Gals

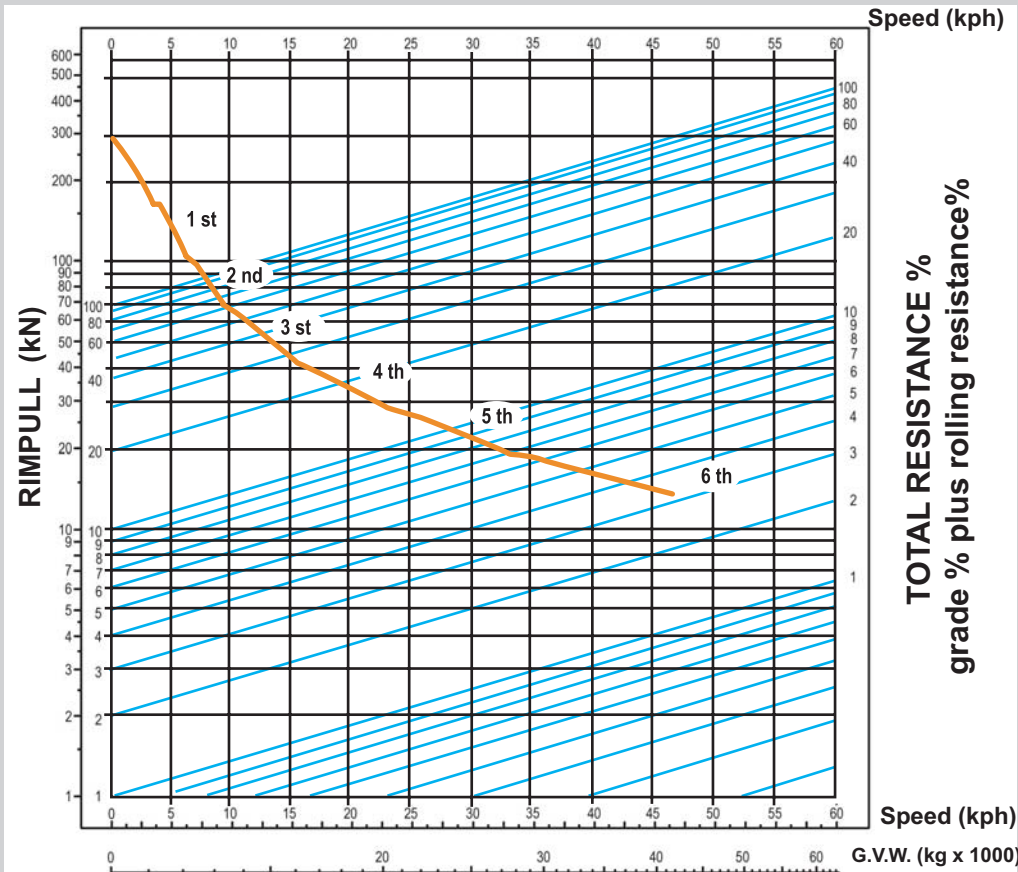

Cross the G.V.W. of the vehicle and the sloped line corresponding to the total resistance %, to determine the corresponding gear on the left and, coming down, the max. speed of the vehicle.

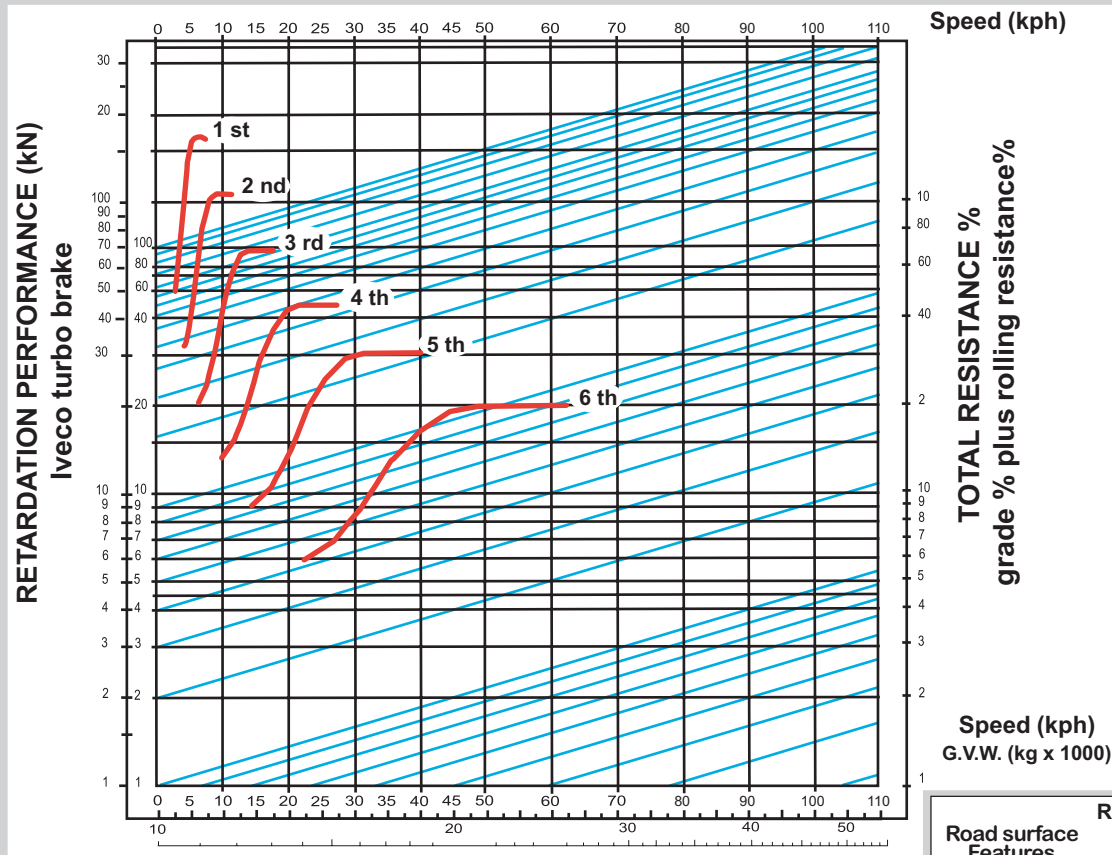

Road surface Features	ROLL RESISTANCE for each t G.V.W.	%
Black top-concrete	15kg	1,5%
Hard packed soil	20kg	2,0%
Excavated not compact	30kg	3,0%
Mud on packed soil	40kg	4,0%
Packed snow	25kg	2,5%
Soft snow	45kg	4,5%
Sand-gravel	100kg	10,0%

Articulated Dumper ADT 25D

Dimensions in mm

Tubeless 23,5R25 Tyres

Loaded : front 15.320 Kg, rear 30.120 Kg

*Unloaded: front 12.155 Kg, rear 10.085 Kg

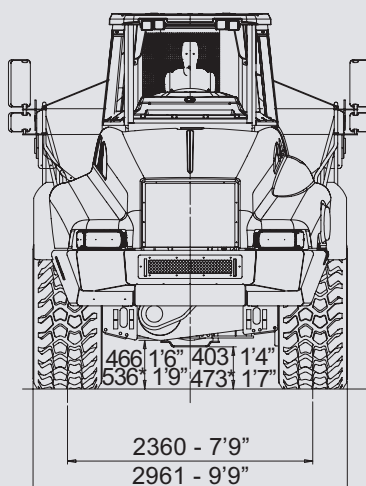
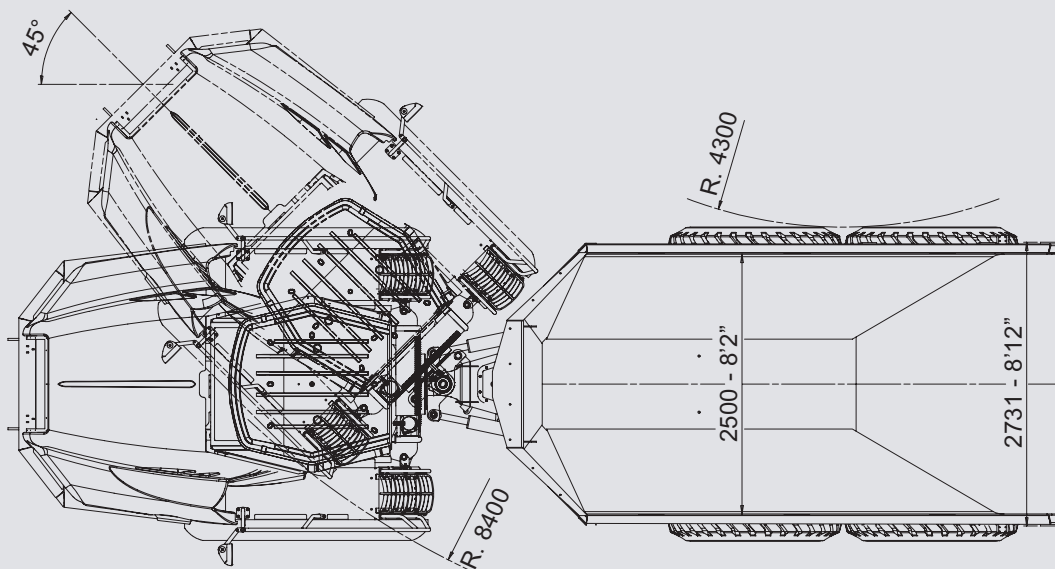
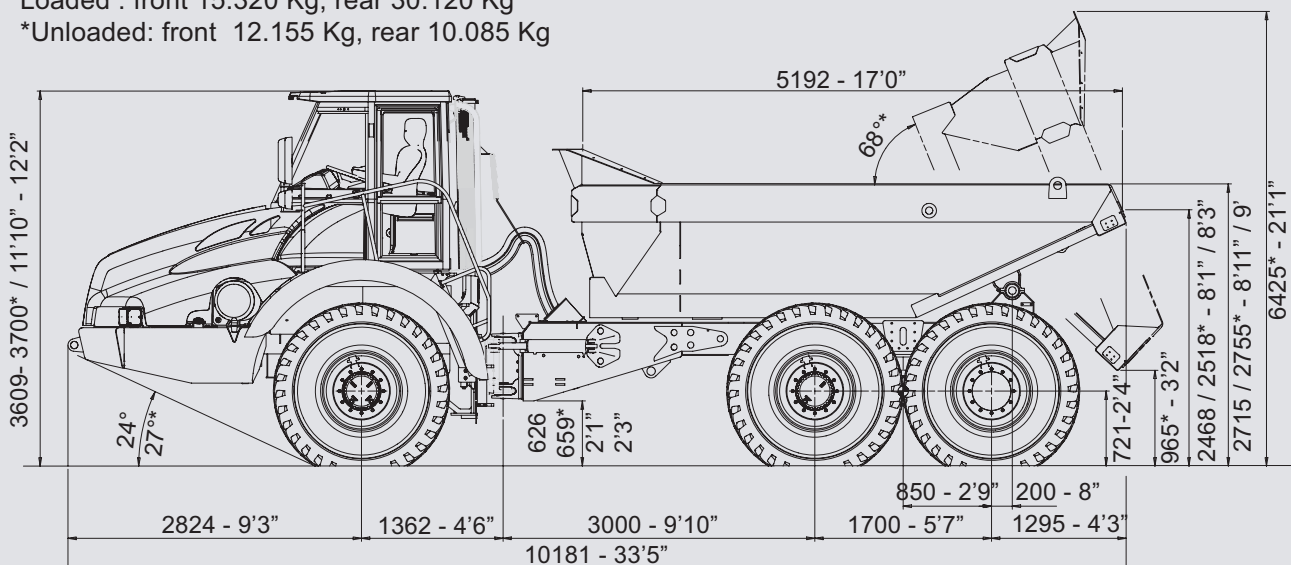



Articulated Dumper

ADT 25D



Features and equipment subject to change without notice

25 M.K.T.- 02.09- A350

ASTRA Veicoli Industriali S.p.A.
Via Caorsana, 79
29100 Piacenza (Italy)
Tel. ++39-523.5431
Fax ++39 523.591773
www.astraspa.com

DEALER