

# 325

**ARTICULATED TRUCK  
TIER II CERTIFIED**

## ENGINE

Model	Cummins 6CTAA-8.3, Tier II certified
Type	4-stroke, turbocharged and air to air cooled diesel
Cylinders	In-line 6
Bore/stroke	4.49 in x 5.31 in (114 x 135 mm)
Displacement	506 in <sup>3</sup> (8.3 L)
Aftercooler	Yes
Horsepower per SAE J1995	
Gross	260 hp (194 kW) @ 2200 rpm
Net	248 hp (184 kW) @ 2200 rpm
Maximum torque @ 1400 rpm	
Net	828 lb-ft (1123 N-m)

## TRANSMISSION

Model	ZF 6WG210
Type	Powershift
Torque converter	Lock up all gears
Ratio	1.77:1
Gears	6 forward/3 reverse
Forward travel – mph (km/h)	
1st	3.2 (5.2)
2nd	5.0 (8.1)
3rd	8.0 (12.9)
4th	12.4 (19.9)
5th	19.2 (30.9)
6th	29.6 (47.6)
Reverse travel – mph (km/h)	
1st	3.4 (5.5)
2nd	8.5 (13.6)
3rd	20.3 (32.6)
Torque proportion – front/rear	33.3%/66.6%
Drop box	Integrated
Gradeability	40% max. (18°)

## BRAKES

Service – caliper	1 per wheel (6), outboard discs (6)
Parking – caliper (2)	protected disc (1) on drive shaft

## TRANSFER BOX

Mounting	Integral
Ranges	1

## DRIVE AXLES

Make/model	ZF/AP 9
Type	Outboard Planetary
Axle	Limited slip
Interaxle	Locking differentials

## CHASSIS

Type	Front/rear box frame
Linkage	Universal joint

## STEERING/ARTICULATION

Frame connection	4 - taper roller
Articulation angle degrees	45°
Steering turns lock-lock	4.5
Secondary steering type	Electric

## SUSPENSION

Front type	Semi-independent arms
Front suspension	Nitrogen-oil
Rear type	2-Rocking beams
Rear suspension	Rods

## TIRES

Rim	5 section
Rim size	19.5 x 25
Optional rim size	17 x 25 or 22 x 25
Standard tire	Tubeless 23.5 x R25

## LOAD BODY

Construction	Ribless
Body tipping angle deg	67°
Body tipping time to raise/lower - sec	14/16
Tip cylinders type	Multi stage
Power down	Yes, 1st stage
Loadover height – ft/in (mm)	8 ft 11 in (2728)

## PAYLOAD

Payload - lbs (kg)	50,706 (23 000)
Capacity, struck	13.9 yd <sup>3</sup> (10.6 m <sup>3</sup> )
Capacity, heaped SAE 2:1	17.4 yd <sup>3</sup> (13.3 m <sup>3</sup> )

## DIMENSIONS

Overall length	32 ft 3 in (9820 mm)
Overall tire width	9 ft 2 in (2795 mm)
Overall height	11 ft 11 in (3638 mm)
Approach angle	27°
Turning radius	
Outside	26 ft 8 in (8182 mm)
Inside	14 ft 3 in (4362 mm)

## CAPACITIES

Fuel tank – gal (l)	86 (325)
Hydraulic reservoir – gal (l)	52.8 (200)
Engine oil – gal (l)	5.8 (22)
Transmission – gal (l)	6.9 (26)
Drive axles	
Front – gal (l)	3.4 (13)
Intermediate – gal (l)	4.5 (17)
Rear – gal (l)	3.4 (13)

## WEIGHT

Weight	41,116 lbs (18 650 kg)
Front:	20,172 lb (9150 kg)
Rear:	20,944 lb (9500 kg)
Total laden weight	91,822 lbs. (41 650 kg)

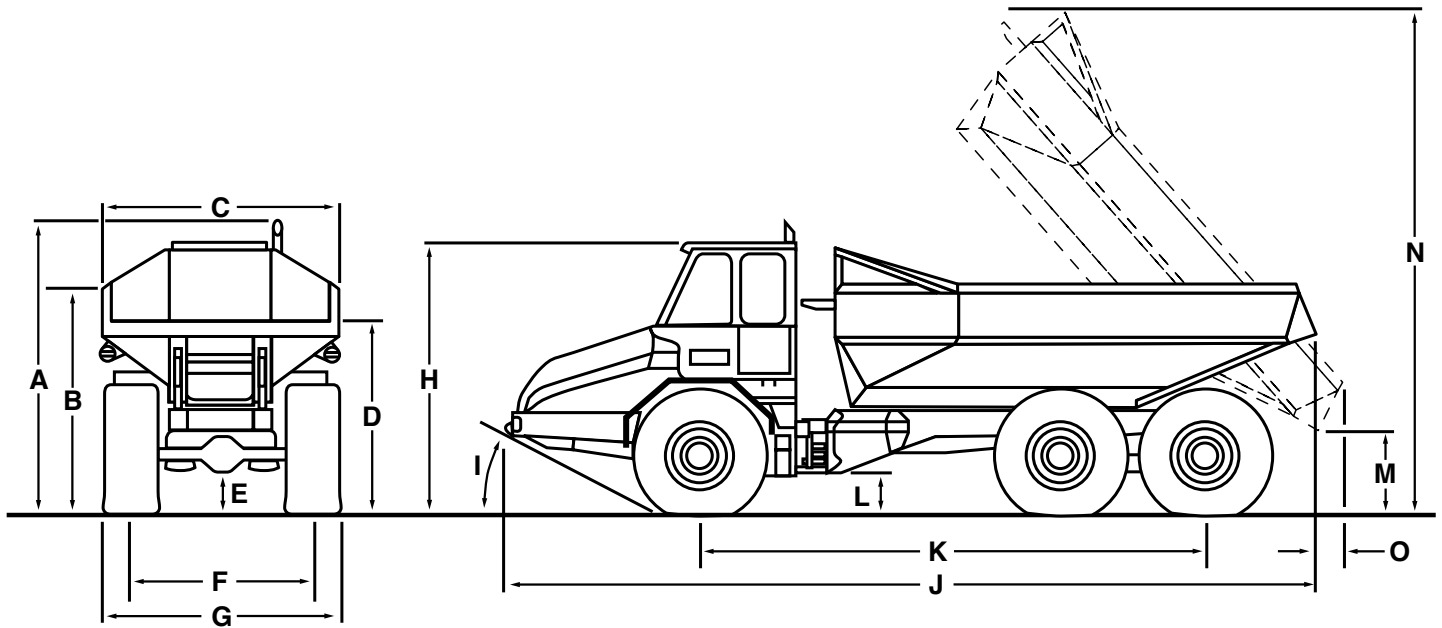

## DIMENSIONS

<b>A.</b>	Overall height	143 in (3.64 m)
<b>B.</b>	Height to side of load body	107 in (2.73 m)
<b>C.</b>	Load body width	98 in (2.48 m)
<b>D.</b>	Height to load bed end	90 in (2.29 m)
<b>E.</b>	Ground clearance – rear differential	20 in (0.52 m)
<b>F.</b>	Tread width – center to center	85 in (2.15 m)
<b>G.</b>	Overall width	110 in (2.79 m)
<b>H.</b>	Height to top of cab	138 in (3.51 m)
<b>I.</b>	Approach angle	27°
<b>J.</b>	Overall length	387 in (9.82 m)
<b>K.</b>	Wheelbase	237 in (6.03 m)
<b>L.</b>	Ground clearance @ articulation point	25 in (0.63 m)
<b>M.</b>	Dump clearance	34 in (0.87 m)
<b>N.</b>	Maximum height – dumping position	254 in (6.45 m)
<b>O.</b>	Rear dumping clearance	14 in (0.35 m)

---

**STANDARD EQUIPMENT**

---

**OPERATOR'S ENVIRONMENT**

ROPS (SAE J1040-ISO 3471)/  
FOPS (SAE J231-ISO 3449) cab  
EPA off-road certified  
Heater/defroster/pressurizer  
Air conditioner  
Windshield wiper and washer, front and side  
Outside rear view mirrors  
Rear window protection grille  
Adjustable steering column  
Air suspension driver's seat  
3 inch wide retractable seat belt  
Passenger seat  
Radio ready  
Windshield sun shade  
Cup holder  
24V to 12V converter

---

**INSTRUMENTATION**

Hourmeter  
Tachometer (rpm)  
Speedometer (mph and km/h)  
Fuel level  
Engine coolant temperature  
Engine oil pressure  
Transmission oil pressure  
Transmission visual display unit

---

---

**OPTIONAL EQUIPMENT**

---

**BODY**

Extensions  
Heating kit  
Rock body  
Rock body extensions  
Rear mechanical gate

---

---

**INDICATOR LIGHTS**

Alternator charging  
Turn signal  
Service brake pressure  
Parking brake engaged  
Intermediate differential interaxle lock  
Differential lock  
4-wheel drive engaged  
6-wheel drive engaged  
Dump body raised  
Warning lights test button

---

**SWITCHES**

Two speed front wiper  
Front wiper washer  
Side wiper washer  
Interior lights  
Horn  
24-volt cigarette lighter w/ashtray  
Hazard warning  
Reverse alarm  
Hi-beam lights  
Turn signal

---

---

**ENGINE**

Cummins 6CTAA-8.3 Turbo Diesel  
Tier II certified  
Air cleaner – pre-cleaner

---

**ELECTRICAL**

24-volt system  
140 amp hour batteries (2) – 1200 CCA  
70 amp alternator  
Head light, stop light, reverse light  
Front and rear turn signals/flashers  
12-volt wiring for radio and CB  
Electrically operating tilt up hood

---

**HYDRAULICS**

Flow amplified  
Hydraulic diagnostic quick couplers

---

**EMERGENCY STEERING SYSTEM**

Electrical steering pump (1)

---

**MISCELLANEOUS**

Auto Lube System  
Tool box

---

---

**TIRES**

23.5R25 Goodyear  
660/65R25 XADN Michelin

---

**OPERATOR'S ENVIRONMENT**

Rotating Beacon  
Closed circuit TV (rear view camera & monitor)  
Heated and remotely controlled mirrors

---

---

**MISCELLANEOUS**

Cold start aid – grid heater

---

**This page intentionally left blank.**

NOTE: All specifications are stated in accordance with SAE Standards or Recommended Practices, where applicable.

NOTE: All engines meet current EPA emissions requirements.

IMPORTANT: CNH America LLC reserves the right to change these specifications without notice and without incurring any obligation relating to such change. CNH America LLC does not warrant the safety or reliability of attachments from other manufacturers.

Case is a registered trademark of CNH America LLC. Any trademarks referred to herein, in association with goods and/or services of companies other than CNH America LLC, are the property of those respective companies.



[www.casece.com](http://www.casece.com)

 **CASE IS A BRAND OF CNH.**  
A GLOBAL LEADER IN CONSTRUCTION EQUIPMENT, AGRICULTURAL EQUIPMENT AND FINANCIAL SERVICES.

Form No. CCE1190501  
Same information as form no. CCE4060401

Printed in U.S.A.

© 2005 CNH America LLC  
All Rights Reserved