



# EJC 417

## Technical Specification

*Payload: 17 tons (15.4 tonnes)*

*Box volume: 11.0 yd<sup>3</sup> (8.4 m<sup>3</sup>)*



### EJC Mining Equipment

Division of Sandvik Mining and Construction Canada Inc.  
4445 Fairview Street, Burlington Ontario, Canada L7L 2A4  
Tel.: (905) 632-4940



Revision Date: 9/3/05

Email: [ejc.loaders@sandvik.com](mailto:ejc.loaders@sandvik.com)  
Web: <http://www.ejc.sandvik.com>

## General Arrangement

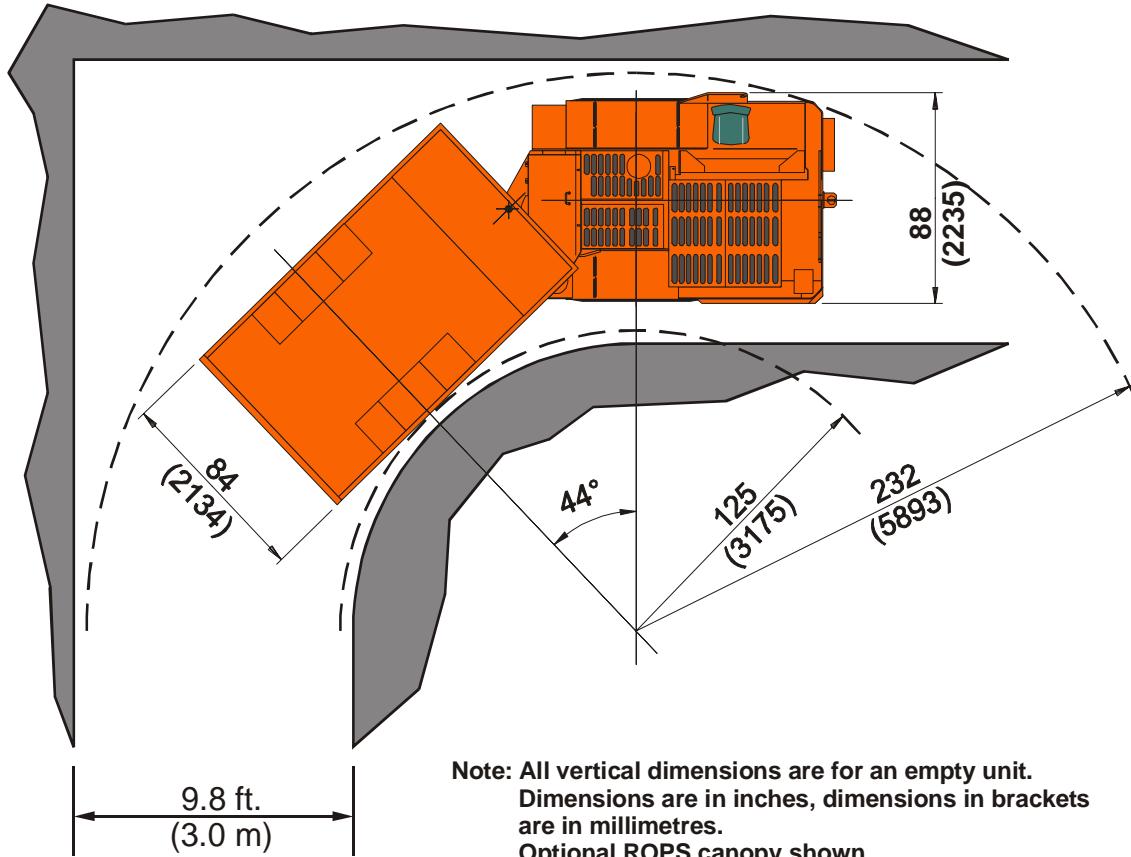
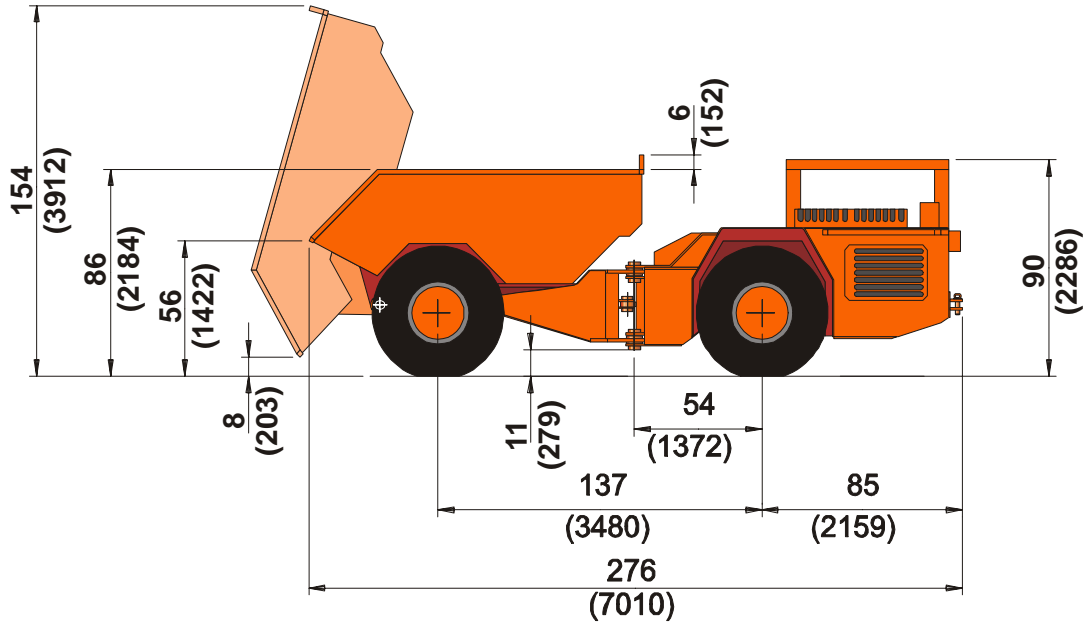

**Note:** All vertical dimensions are for an empty unit.  
 Dimensions are in inches, dimensions in brackets are in millimetres.  
 Optional ROPS canopy shown.

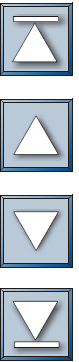



## Standard Unit Specifications

### General Information

#### Main Dimensions

Total length	7010 mm	276 in
Total width	2235 mm	88 in
Over all height	2286 mm	90 in
Height of dump box	2184 mm	86 in
Dump height	3912 mm	154 in

#### Operating Weights

Total	15014 kg	33100 lb.
front axle	9609 kg	21184 lb.
rear axle	5405 kg	11916 lb.

#### Loaded Weights

Total	30436 kg	67100 lb.
front axle	10653 kg	23436 lb.
rear axle	19806 kg	43664 lb.

#### Capacities

Payload	15.4 tonnes	17 tons
Box volume	8.4 m <sup>3</sup>	11.0 yd <sup>3</sup>

#### Dump Box Motion Times

Discharging time	14 sec.
Dumping angle	75 sec.

#### Driving Speeds Forward and Reverse (Loaded)

1st gear	4.7 km/h	2.9 m.p.h.
2nd gear	9.8 km/h	6.1 m.p.h.
3rd gear	16.9 km/h	10.5 m.p.h.
4th gear	29.1 km/h	18.1 m.p.h.

#### Frame

Rear and front frame	Welded steel box construction
Material	G40.21 - 50wt Cat. #3
Central hinge	full plate, clevis type with spherical bearings
Dump box	Welded steel box construction
Material	G40.21 - 50wt Cat. #3

### Power Train

#### Engine

Diesel engine	Detroit Diesel Series 40E	
Output	156 kW (210 Hp) @ 2 200 rpm	
Torque	705 Nm (520 lbf-ft) @ 1 500 rpm	
Number of cylinders	In line, 6	
Displacement	7.64 l	466 in <sup>3</sup>
Cooling system	Liquid cooled	
Combustion principle	Turbo charged, after cooled, direct injected, 4 cycle	
Air filtration	Dry type	
Electric system	24 V	
Exhaust system	Catalytic purifier with silencer	
Fuel tank capacity	148 l	39 US gal.

#### Transverter

Dana SOH 13.7 LMHR 32421	4 speed forward and reverse, single stage converter, 2.13:1 stall torque ratio.
--------------------------	---

#### Axles

Front	Dana SOH 16D2149, standard differential, oscillating $\pm 8^\circ$
Rear	Dana SOH 16D2149, standard differential, fixed

#### Tires

Tire size	14:00 R24		
Type	Michelin XKDIA***		
Air pressure, front	552 kPa	5.52 bar	80 psi
Air pressure, rear	552 kPa	5.52 bar	80 psi

### Systems

#### Steering Hydraulics

Full hydraulic power steering, centre articulated with a double acting steering cylinder. Open centre system with a gear pump and pilot operated stick steer control.

### EJC Mining Equipment

Division of Sandvik Mining and Construction Canada Inc.  
4445 Fairview Street, Burlington Ontario, Canada L7L 2A4  
Tel.: (905) 632-4940



Revision Date: 9/3/05

Email: [ejc.loaders@sandvik.com](mailto:ejc.loaders@sandvik.com)  
Web: <http://www.ejc.sandvik.com>



### Turning Radius

Inner	3175 mm	125 in
Outer	5893 mm	232 in
Turning angle	44 °	

### Main Components

Hydraulic pump	Gear pump	
Control valve	Pilot operated	
Steering cylinder	EJC 127 mm bore X 51 mm rod (5.0" X 2.0")	

### Pressure Settings

Main relief	13.8 MPa	138 bar	2000 psi
Port relief valves	13.8 MPa	138 bar	2000 psi

### Dump Box Hydraulics

Full hydraulic open-centre system with one gear pump. Electric push button dump box control located on the steer stick.

### Main Components

Dump cylinder	2 stage telescopic 184/152 mm (7.25/6.0")	
Hydraulic pump	Gear pump	
Control valve	Pilot operated	

### Pressure Settings

Main relief	13.8 MPa	138 bar	2000 psi
Port reliefs	13.8 MPa	138 bar	2000 psi
Hyd. oil tank capacity	125 l	33 US gal.	

### Standard Brakes

Service brakes are spring applied/hydraulically released, liquid cooled (LCB) multi-disc brakes on all wheels with two separate circuits for the front and rear axles. Service brakes also function as an emergency brake, when the emergency brake system is engaged.

### Main Components

Pressure accumulators	Piston type with charging valve
Brake pedal valve	Modulated

### Electrical Equipment

Alternator	24V 60 A, min
Batteries	2 x 12 V, 950 CCA
Starter	24 V, Heavy Duty
Driving lights	4pcs front, 2pcs rear

### Other Standard Equipment

- Electric shift
- Central hydraulic pressure test points
- Central manual lubrication system
- SAE hose fittings

### Manuals

All manuals are delivered on CD-ROM in Adobe Acrobat (PDF) format.

### Distribution

Manual Type	Customer	Market Area
Spare parts manuals	3 Copies	1 Copy
Operator's manual	3 Copies	1 Copy
Service manual	3 Copies	1 Copy

## Optional Equipment Specifications

### Available Alternative Equipment

Auto lube system	Lincoln modular
------------------	-----------------

### Available Add-On Options

Dump box	Split dump box rework	
	Abrasion resistant box liners	
Operator's compartment	SAE ROPS canopy	
	Enclosed operator's cab with A/C (solid mounts)	
Fire suppression systems	Manual - Ansul 6 nozzles, 1 tanks	
	Automatic (Checkfire II) - Ansul 6 nozzles, 1 tanks	
Hand held fire extinguishers	4.5 kg	10 lb.
	9.1 kg	20 lb.
Emergency steering system	SAE J-1511, electric	



## EJC Mining Equipment

Division of Sandvik Mining and Construction Canada Inc.  
4445 Fairview Street, Burlington Ontario, Canada L7L 2A4  
Tel.: (905) 632-4940



ISO 9001:2000  
FM 62442



ISO 14001  
EMS 71449

Revision Date: 9/3/05

Email: [ejc.loaders@sandvik.com](mailto:ejc.loaders@sandvik.com)  
Web: <http://www.ejc.sandvik.com>



## Tractive Effort Curve (Metric Units)

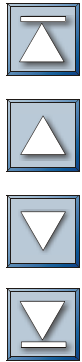
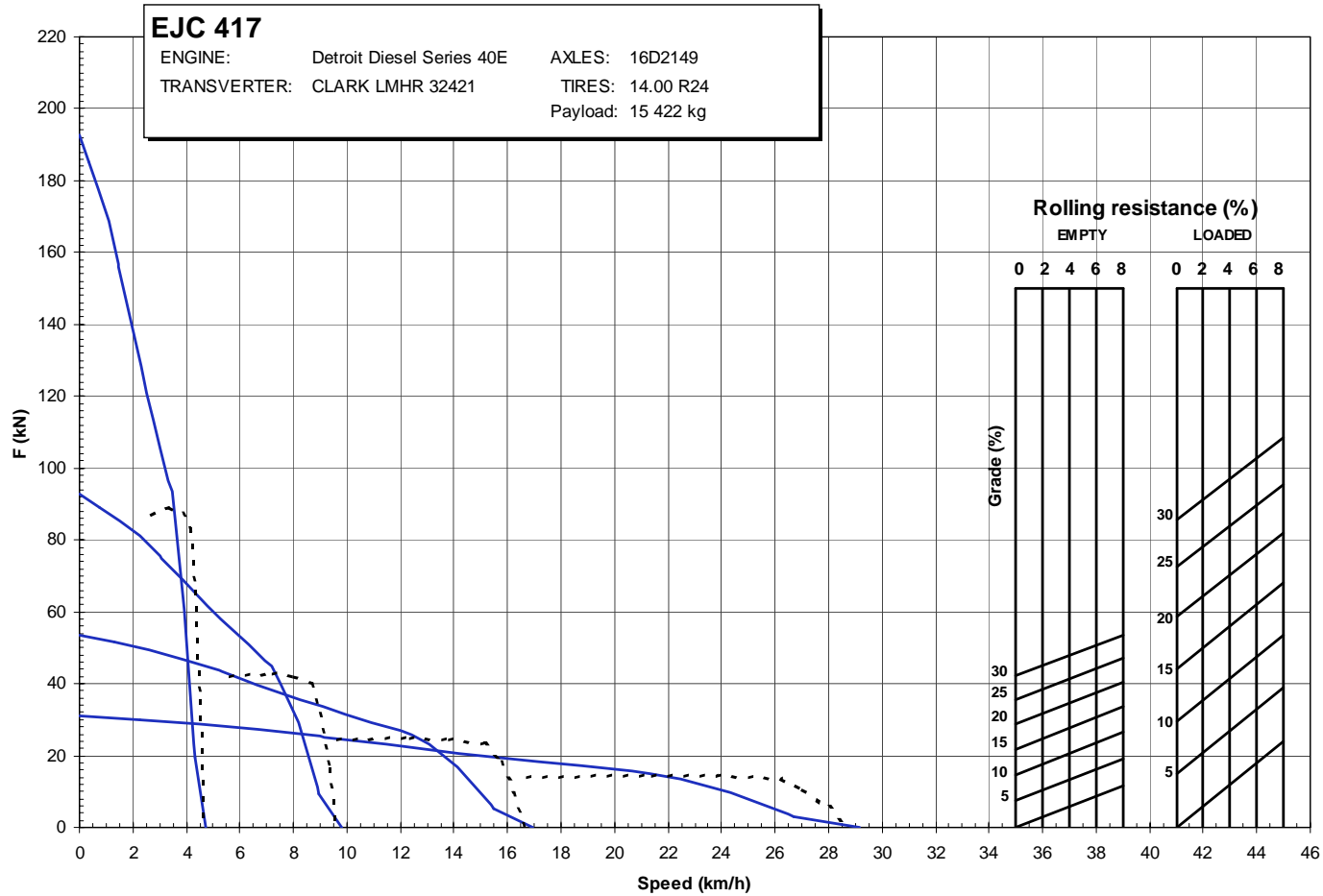

**EJC Mining Equipment**

Division of Sandvik Mining and Construction Canada Inc.  
 4445 Fairview Street, Burlington Ontario, Canada L7L 2A4  
 Tel.: (905) 632-4940



Revision Date: 9/3/05

Email: [ejc.loaders@sandvik.com](mailto:ejc.loaders@sandvik.com)  
 Web: <http://www.ejc.sandvik.com>



## Tractive Effort Curve (US Units)

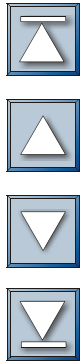
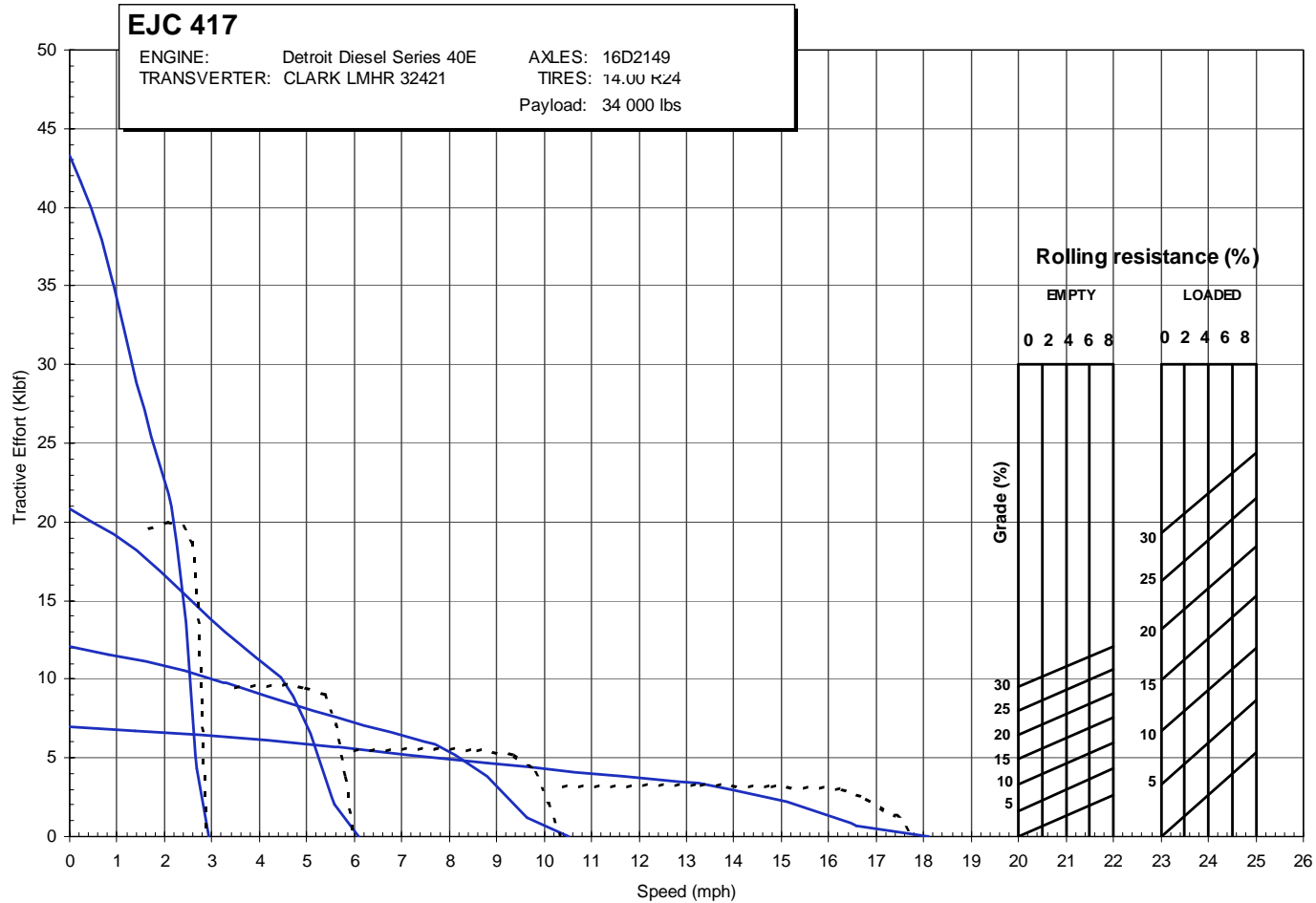



## Productivity Curve (Metric Units)

EJC 417 PRODUCTIVITY

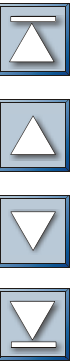
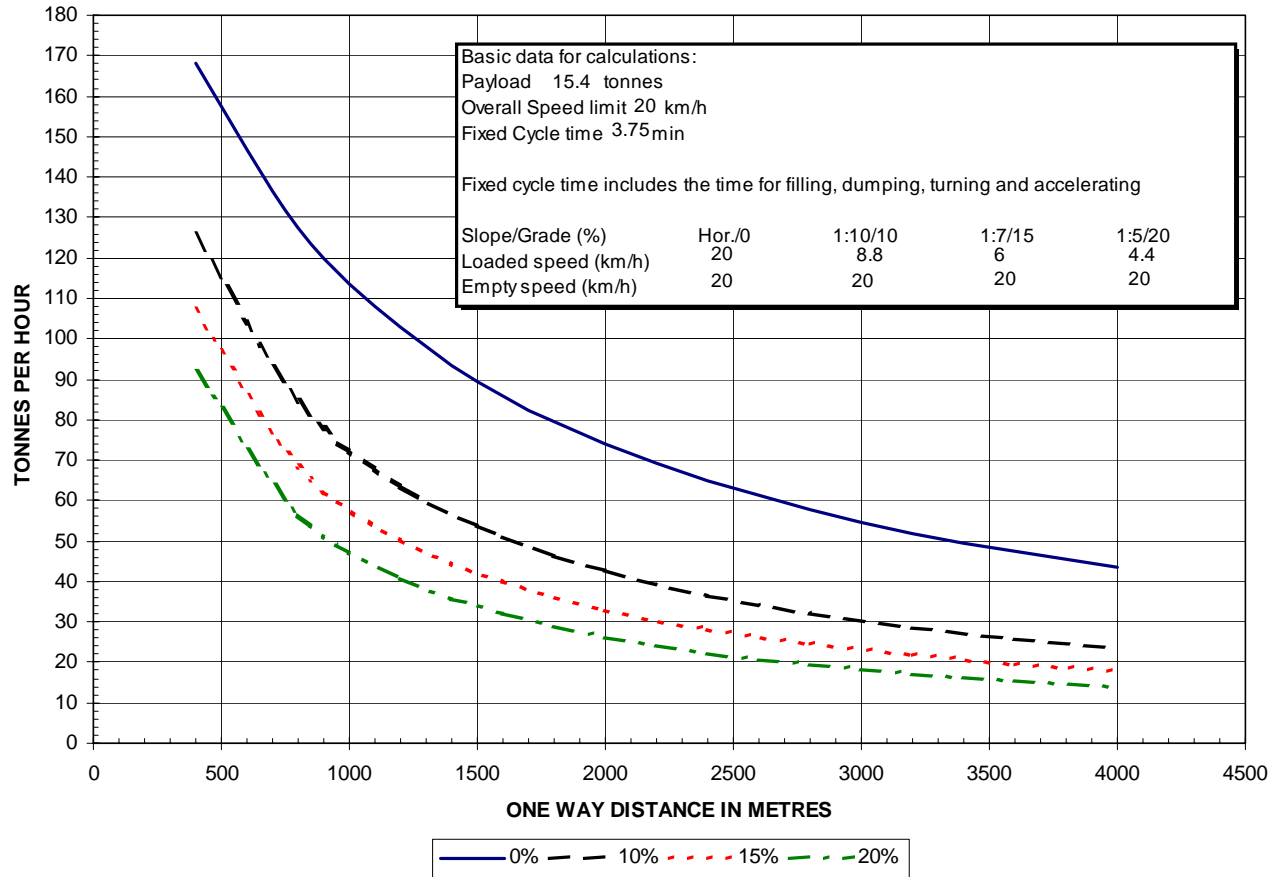

**EJC Mining Equipment**

Division of Sandvik Mining and Construction Canada Inc.  
 4445 Fairview Street, Burlington Ontario, Canada L7L 2A4  
 Tel.: (905) 632-4940



Revision Date: 9/3/05

Email: [ejc.loaders@sandvik.com](mailto:ejc.loaders@sandvik.com)  
 Web: <http://www.ejc.sandvik.com>



## Productivity Curve (US Units)

EJC 417 PRODUCTIVITY CURVE

