

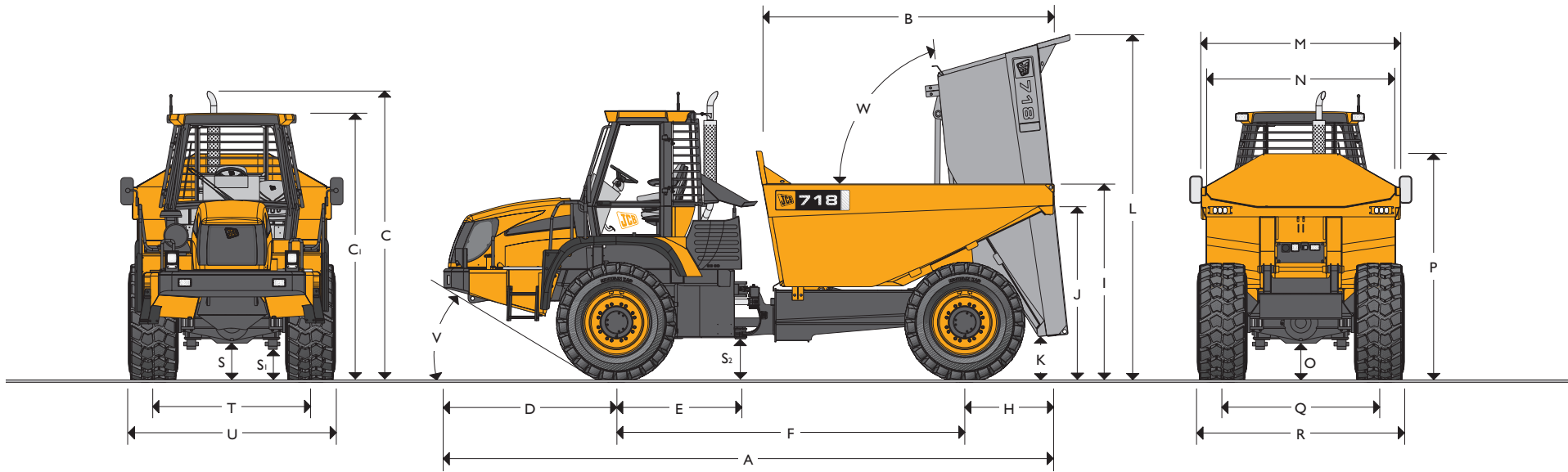

JCB ARTICULATED DUMP TRUCK | 718



MAX. OPERATING WEIGHT: 28.78 tonnes (63445lb)
 MAX. HORSEPOWER: 132 kW (177hp)



STATIC DIMENSIONS

	mm (ft-in)
A Overall length	7524 (24-7)
B Body length	3745 (12-3)
C Max. height	3560 (11-7)
C _i Height to top of cab	3240 (10-6)
D Front axle to front bumper	2174 (7-1)
E Front axle to rear of front unit	1575 (5-1)
F Wheelbase (front axle to rear axle)	4220 (13-8)
H Rear axle to rear bumper	1130 (3-7)
I Height to top of body	2380 (7-8)
J Height to lip of body	2130 (7-0)
K Min. height to body when tipped	470 (1-5)
L Max. height to body when tipped	4505 (14-8)
M Max. external body width	2502 (8-2)
N Max. internal body width	2370 (7-8)

	mm (ft-in)
O Max. ground clearance (rear diff)	430 (1-4)
P Max. body height to spill guard	2790 (9-2)
Q Wheel track (rear)	1948 (6-4)
R Overall width (rear)	2607 (8-6)
S Max. ground clearance (front diff)	430 (1-4)
S _i Max. ground clearance (front suspension arm)	310 (1-0)
S ₂ Ground clearance	420 (1-4)
T Wheel track (front)	1948 (6-4)
U Overall width	2607 (8-5)
V Departure angle (front)	degrees 30
W Body tip angle	degrees 84
Load capacity	tonnes/lb 16.33 (36000)
Body – heaped	m ³ (yd ³) 9.6 (12.56)

Overall dimensions based on an unladen machine equipped with Michelin 650/65 R25 XAD tyres.



JCB ARTICULATED DUMP TRUCK | 718



ENGINE

Type	4 stroke, direct injection	
Model	6BTAA	
Capacity	litres (in ³)	5.9 (360)
Bore	mm (in)	102 (4)
Stroke	mm (in)	120 (4.75)
Aspiration	Turbocharged/charge cooled	
Cylinders	6	
Power rating		
Max. power	kW (HP) @ 2000rpm	132 (177)
Gross power to SAE J1995/ISO 14396	kW (HP) @ 2200rpm	129 (173)
Net power to SAE J1995/ISO 14396	kW (HP) @ 2200rpm	125 (168)
Torque rating		
Max. torque	Nm (lbf ft) @ 1300rpm	786 (580)
Net torque	Nm (lbf ft) @ 1300rpm	748 (551)

TRANSMISSION

Transmission	Type	Smoothshift
	Make	ZF
	Model	6WG160
Torque converter	Type	Single stage
	Torque converter ratio	1.792:1

AXLES

Type	Epicyclic hub reduction
Make	Graziano
Model	PR15
Overall axle ratio	23.538:1

SUSPENSION

Type (front)	4-bar parallel link
Make	JCB
Type (rear)	Fixed
Make	n/a

TRAVEL SPEEDS

Assumes fitment of Michelin 650/65 R25 tyres		kph (mph)
Forward	First	6.03 (3.75)
	Second	9.31 (5.79)
	Third	14.30 (8.89)
	Fourth	21.9 (13.61)
	Fifth	32.3 (20.07)
	Sixth	50.0 (31.07)
Reverse	First	6.0 (3.73)
	Second	15.0 (9.32)
	Third	32.0 (19.86)

HYDRAULICS

Steering and tipping	Pump type	Gear	
	Pump: max flow @ 2200rpm	l/min (UK gal/min)	114 (25.0)
	Pump: max pressure (MRV)	bar (psi)	207 (3000)
Braking	Pump type	Gear	
	Pump: max flow @ 2200rpm	l/min (UK gal/min)	17.6 (3.9)
	Pump: max pressure	bar (psi)	175 (2500)

SERVICE FILL CAPACITIES

	litres (UK gal)
Hydraulic system	160 (35)
Fuel tank	210 (46)
Engine oil sump	16.3 (3.58)
Transmission system	35 (7.7)
Axle oil (front)	29 (6.38)
Axle oil (rear)	29 (6.38)
Engine coolant system	33 (7.26)

ELECTRICAL SYSTEM

System voltage	Volt	24
Alternator output	Amp hour	70
Battery capacity	Amp hour	2 x 115



JCB ARTICULATED DUMP TRUCK | 718



BODY

Tipping angle	degrees	84
Body plate thickness (front)	mm (ft-in)	6 (0-020)
Body plate thickness (side)	mm (ft-in)	6 (0-020)
Body plate thickness (bottom/chute)	mm (ft-in)	6 (0-026)
Yield strength	N/mm ² (psi)	1000 (145000)
Tensile strength	N/mm ² (psi)	1245 (181000)
Hardness (min)	HB	400
Body raise (laden)	seconds	12
Body lower (laden)	seconds	8
Scow angle	degrees	25

STANDARD EQUIPMENT

Engine: 6 cylinder, direct injection diesel engine. Wastegate turbocharger charged cooler for maximum torque and minimum exhaust smoke. 3 stage dry type-cyclonic air cleaner with primary and safety elements. Stainless steel exhaust system, fuel sedimenter, twin bowl fuel filters.

Suspension: Front suspension is a four bar parallel link mechanism connected via a gas strut to a pre charged accumulator that dampens the vibration. The system is self-levelling whether laden or un-laden.

Transmission: 6 forward and 3 reverse speed remote mount smoothshift transmission with integral lock up torque converter. Manual or automatic selection. Electrical 2/4 wheel drive selection.

Axles: Pad mounted to the front suspension and the rear chassis. Limited Slip Differential in both axles. Planetary wheel hub reduction.

Steering: Double acting hydrostatic system. Priority steer valve. Emergency steering via a ground driven pump.

Brakes: Dual circuit, hydraulic power dry disc type with braking on all four wheels. Electrically operated dry disc parking brakes on the driveline, spring applied and hydraulically released. Brake disc guards fitted as standard.

Hydraulics: Twin gear pump system comprising main pump for priority steer and body tip, and a second pump for braking. Emergency steer via a ground driven pump.

Cab: ROPS and FOPS safety structure. Fully adjustable air suspension seat. Adjustable steering column. Air conditioning. Laminated safety glass. Electronic monitoring panel with LCD message display which includes body up warning light. Front & rear screen wash / wipe. 3 speed heater / demisting with replaceable air filter. LH & RH opening doors. Single lever transmission selector. Single lever hydraulic tip control. Combination stalk controls for lights, wipers, horn, direction indicators. Separate side console for auxiliary switches. Cigar lighter, ashtray, interior light, sun visor, external rear view mirrors, and operator's storage facilities.

Electrical: Road lights front and rear, front working lights, reversing alarm and light, rear fog lights, horn, battery isolator, beacon, radio fittings, 70 amp alternator, 24-12 volt in cab converter.

Bodywork: Flexible front steps, non-slip walkways, recovery hitch, lifting lugs (rear body), engine access cover. Rear cab mounted spill guard. Cast 360 deg centre hitch.

Body: Constructed from high strength steel with large box section stiffeners and a Hardox floor. Large target area and load retention. Two single stage double acting cylinders located within rear chassis.

OPTIONAL EQUIPMENT

Reversing camera; Heated seat and mirrors; Biodegradable hydraulic oil; Smart reverse alarm; 3" seat belt; Mechanical tail gate; Greedy boards; Window etching; Spacetrac.

TURNING CIRCLE

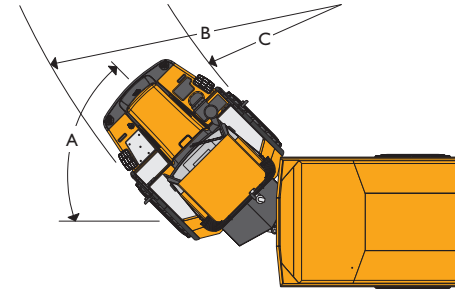

		mm (ft-in)
A	Articulation angle	degrees
B	Clearance radius	7520 (24-7)
C	Turning radius	4440 (14-6)

OPERATING WEIGHTS

		Laden	Unladen
Front	tonnes (lb)	11.05 (24361)	7.62 (16799)
Rear	tonnes (lb)	17.73 (39088)	4.83 (10648)
Total	tonnes (lb)	28.78 (63449)	12.45 (27448)
Payload	tonnes (lb)	16.33 (36000)	-

Includes operator (80kg) and a full fuel tank.

CHANGES TO GROUND BEARING PRESSURES

Manufacturer	Tyre Size	Type	Laden		Unladen		Tyre Pressure	
			Front	Rear	Front	Rear	Front	Rear
			kPa (PSI)	kPa (PSI)	kPa (PSI)	kPa (PSI)	kPa (PSI)	kPa (PSI)
Michelin	650/65 R25	XAD	117 (17)	187 (27)	82 (12)	48 (7)	248 (36)	400 (58)
Nokian	750/55 26.5	TRS LS-2	96 (14)	158 (23)	68 (10)	41 (6)	224 (32.5)	448 (65)
Trelleborg	850/45 B30.5	423TL	83 (12)	137 (20)	55 (8)	34 (5)	200 (29)	345 (50)

Ground bearing pressure @ 15% sinkage.

CHANGES TO OPERATING DIMENSIONS

Manufacturer	Tyre Size	Type	Dimensional changes				Operating weight
			U	T	R	Q	kg (lb)
			mm (in)	mm (in)	mm (in)	mm (in)	
Michelin	650/65 R25	XAD	0	0	0	0	0
Nokian	750/55 26.5	TRS LS-2	+180 (7.0)	+90 (3.5)	+180 (7.0)	+90 (3.5)	-772 (1698)
Trelleborg	850/45 B30.5	423TL	+380 (14.5)	+190 (7.5)	+380 (14.9)	+190 (7.5)	-980 (2156)



A GLOBAL COMMITMENT TO QUALITY

JCB's total commitment to its products and customers has helped it grow from a one-man business into Britain's largest privately owned manufacturer of backhoe loaders, crawler excavators, wheeled excavators, telescopic handlers, wheeled loaders, dump trucks, rough terrain fork lifts, industrial fork lifts, mini/midi excavators, skid steer loaders and tractors.

By making constant and massive investments in the latest production technology, the JCB factories have become some of the most advanced in Europe.

By leading the field in innovative research and design, extensive testing and stringent quality control, JCB machines have become renowned all over the world for performance, value and reliability.

And with a global sales and service network of over 400 distributors and agents, the company exports over 70% of its production to all five continents.

Through setting the standards by which others are judged, JCB has become one of Britain's most impressive success stories.

