

KOMATSU®

HM300-1

GROSS HORSEPOWER

250 kW 335 HP

NET HORSEPOWER

242 kW 324 HP

MAXIMUM GVW

49,875 kg 109,960 lb

**HM
300**

ARTICULATED DUMP TRUCK



Photo may include optional equipment

GALEO

HM300-1 Articulated Dump Truck

WALK-AROUND

The HM300-1 offers all around maximum productivity with faster travel speed and many features that enhance efficiency, while reducing maintenance costs. From construction sites to landfills- the HM300-1 excels.

Tiltable cab can be tilted rearward to provide easy service.

Wide, spacious cab

- The wide cab offers a comfortable operator environment
- Viscous mounts support the cab while absorbing vibrations and noise
- Interior noise level 76 dB(A)

High performance and environment-friendly SAA6D125E-3 engine

- Gross horsepower 250 kW 335 HP
- Meets North American EPA Tier II emission regulations



Fully hydraulic articulated steering

- Light and easy operation
- Minimum turning radius 7.96 m 26'1"

Differential locks for excellent traction in rough terrain.

The oil-cooled multiple-disc interaxle lock can be turned on and off during travel. In addition, the limited slip differentials prevent the tires on either side from slipping on soft ground for maximum traction.

HM300-1

ARTICULATED DUMP TRUCK

GROSS HORSEPOWER
250 kW 335 HP @ 2000 rpm

NET HORSEPOWER
242 kW 324 HP @ 2000 rpm

MAXIMUM GVW
49,875 kg 109,960 lb

Komatsu designed, electronically controlled transmission for a comfortable ride.

F6-R2 counter-shaft type transmission with K-ATOMiCS (Komatsu Advanced Transmission with Optimum Control System).

Easy-to-Load Body

- Heaped capacity 16.6 m³ 21.7 yd³
- Low loading height 2790 mm 9'2"
- Robust body constructed of thick wear-resistant steel having 400 Brinell hardness



Hydro-pneumatic Suspension for all terrains.

The hydro-pneumatic suspension in both front and rear suspensions assures a comfortable ride even over rough terrain.

Maintenance-free oscillating hitch with tapered roller bearings

means lower operating costs by eliminating the need to lubricate the hitch.

Reliable, continuously cooled, wet type multiple-disc brake and retarder

- Fully hydraulic controlled wet multiple-disc brakes
- Retarder Absorbing Capacity (continuous descent)
349 kW 468 HP
449 kW 602 HP (with optional exhaust retarder)



Komatsu's highly productive, innovative technology, environmentally friendly machines built for the 21st century.

PRODUCTIVITY FEATURES

The combination of high travel speeds and an efficient engine with low emissions delivers maximum productivity at the lowest cost.

High Performance SAA6D125E-3 Komatsu Engine

This engine delivers faster acceleration and higher travel speeds with the highest horsepower per ton in its class. Advanced technology, such as Common Rail Injection system (CRI), air to air aftercooler, and an efficient turbo-charger enables the engine to meet the North American EPA Tier II emission regulations. High torque at low speed, impressive acceleration, and low fuel consumption ensures maximum productivity.



Komatsu Designed Electronically Controlled Countershaft Transmission

The Komatsu designed Electronically Controlled Transmission called K-ATOMICS has been successfully employed in Komatsu's rigid dump trucks. The electronic clutch modulation system ensures proper clutch pressure when the clutch is engaged. The total control system controls both the engine and transmission by monitoring the vehicle conditions. This high technology system assures smooth shifts without shock.



Komatsu Designed Differential Locking Systems

The full-time six-wheel drive system reduces slippage. A wet multiple-disk interaxle clutch also locks the three axles in unison for greater traction. The interaxle lock can be switched on and off while the truck is travelling, thereby boosting productivity. In addition, limited slip differentials prevent the tires on either side from slipping on soft ground.

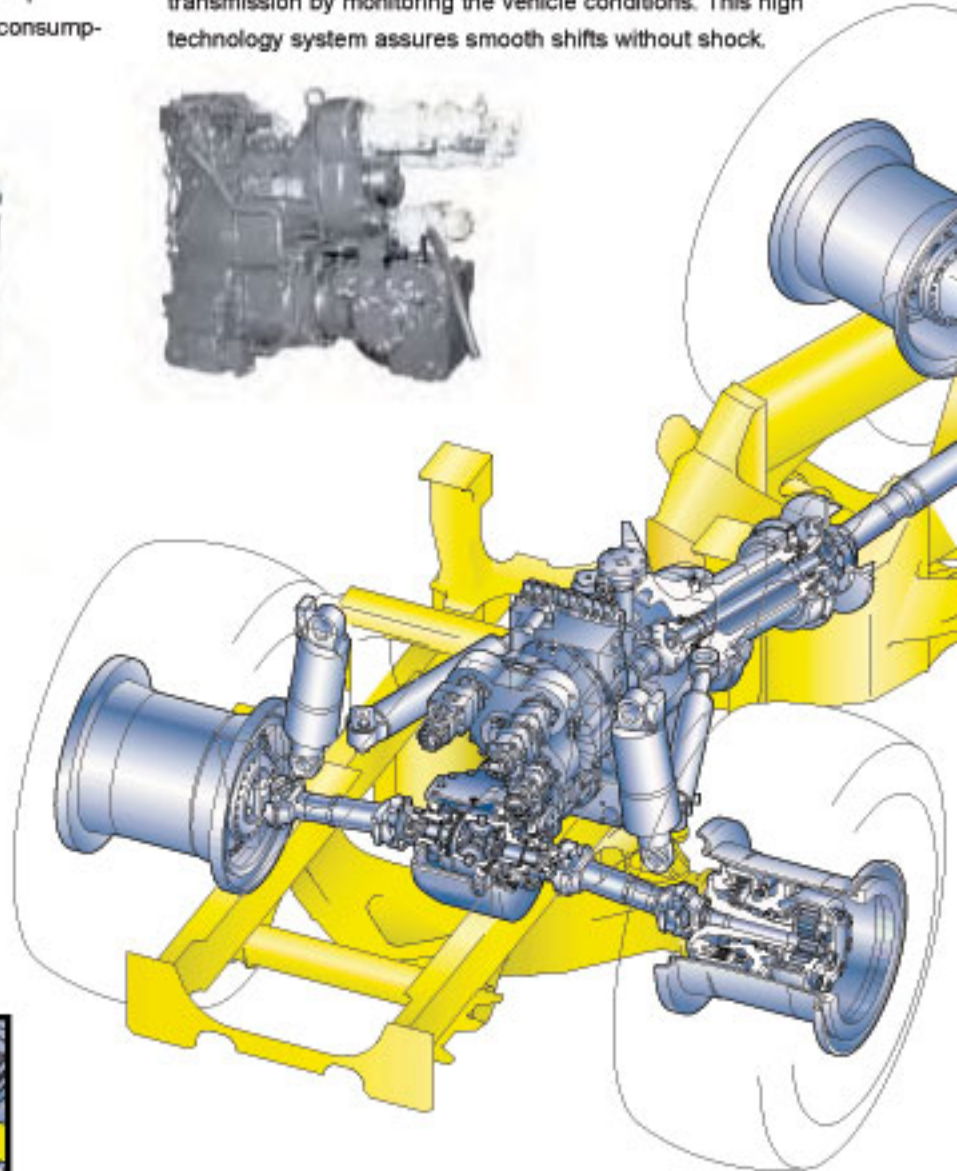
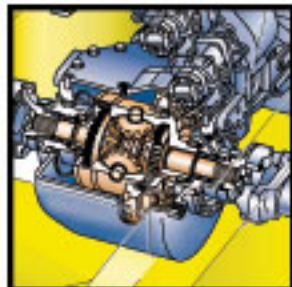

Hydro-pneumatic Suspension

The same hydro-pneumatic suspension has been proven on Komatsu's rigid dump trucks. The front axle hydro-pneumatic suspension employs "De Dion" type design, allowing the machine to ride more smoothly over bumps. The rear-axles are mounted on a dynamic equalizer structure equipped with hydro-pneumatic suspension. The entire vehicle's suspension delivers a comfortable ride and maximizes productivity.

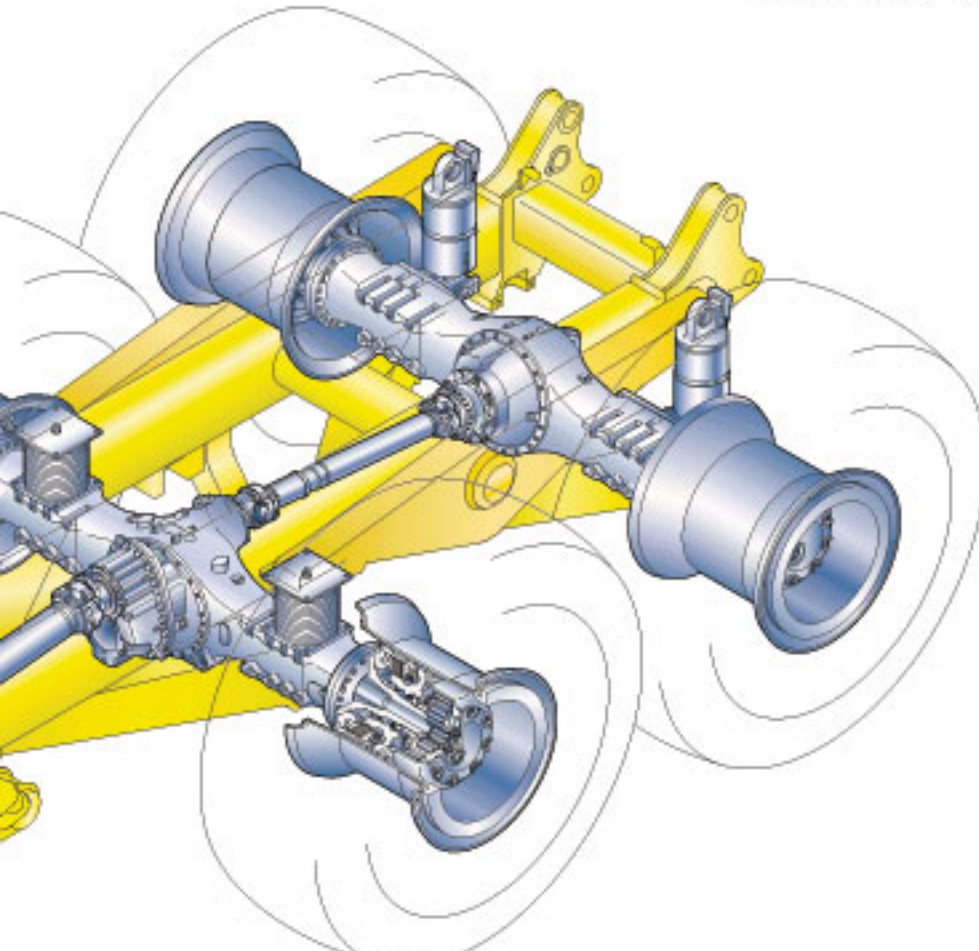
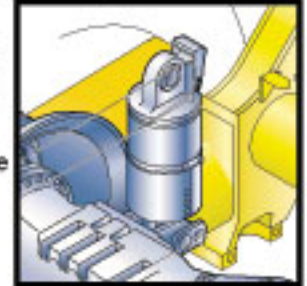

Large Capacity Body and Box Section Frame Structure

The 16.6 m³ 21.7 yd³ heaped capacity is among the highest in its class. The low loading height of 2790 mm 9'2" enables easy loading. The body is built of thick wear-resistant steel with a Brinell hardness of 400, and the body shape provides excellent load stability. Rugged enough for the toughest jobs, the HM300's frame is designed using a rigid box structure with high strength low alloy steel.

Hydraulically Controlled Wet Multiple-Disc Brakes and Retarder

Wet multiple-disc brakes have been proven on Komatsu dump trucks and wheel loaders ensuring highly reliable and stable brake performance. The large-capacity, continuously cooled, wet-multiple disc brakes also function as a highly responsive retarder which gives the operator greater confidence at higher speeds when travelling downhill.

Retarder Absorbing Capacity (continuous descent):

349 kW 468 HP

449 kW 602 HP (with optional exhaust retarder)

Articulated Steering

Fully hydraulic articulated steering offers low-effort operating performance and maneuverability. A minimum turning radius of only 7.96 m 26'1" provides the freedom to move about in confined areas.



OPERATOR ENVIRONMENT

Komatsu has developed a state-of-the-art, wide comfortable cab. The low level of vibration and noise ensure maximum productivity from the operator.

Wide, Spacious Cab with Excellent Visibility

The wide cab provides a comfortable space for the operator and a full size buddy seat. Large electrically operated windows and the operator's seat positioned to the left side ensures superior visibility.

Ergonomically Designed Cab

The ergonomically designed operator's compartment makes it very easy and comfortable for the operator to use all the controls. The result is more confident operation by operators and greater productivity.

Easy-to-See Instrument Panel

The instrument panel makes it easy to monitor critical machine functions. In addition, a caution light warns the operator of any problems that may occur. Problems are recorded in the monitor and indicated as service codes. This makes the machine very friendly and easy to service.



Steering Wheel and Pedals

Low effort pedals reduce operator fatigue when working continuously for long periods. The tiltable, telescoping steering column enables operators to maintain the optimum driving position at all times.



Built-in ROPS/FOPS

These structures conform to ISO 3471 and SAE J1040-1988C standards.

Hydro-pneumatic Suspension for all Terrains

The hydro-pneumatic suspension assures a comfortable ride even over rough terrain and ensures maximum productivity and operator confidence.

Viscous Cab Mounts

Viscous mounts reduce the noise transmitted to the cab and achieve a quiet 76 dB(A) noise level



Air Suspension Seat

The air suspension, fabric-covered seat which is adjustable to the operator's weight is provided as standard. The air suspension seat dampens vibrations transmitted from the machine and reduces operator fatigue as well as holding the operator securely to assure confident operation.

Electric Body Dump Control Lever

The low effort lever makes dumping easier than ever.

Auxiliary Steering and Parking Brakes

Supplementary steering and secondary brakes are standard features.

Steering: ISO 5010-1992, SAE J1511

Brakes: ISO 3450-1996, SAE J1473



EASY

MAINTENANCE

The HM300-1 has been designed to keep service time down and productivity up by having a maintenance-free oscillating hitch, a reduced number of grease points, easy access to filters, and longer intervals between oil changes.

Tiltable Cab

The cab can be tilted rearward to provide easy maintenance/service for the engine and transmission.

Note: An external hydraulic pump is required to tilt the cab or a service crane can be used after removing only eight bolts.

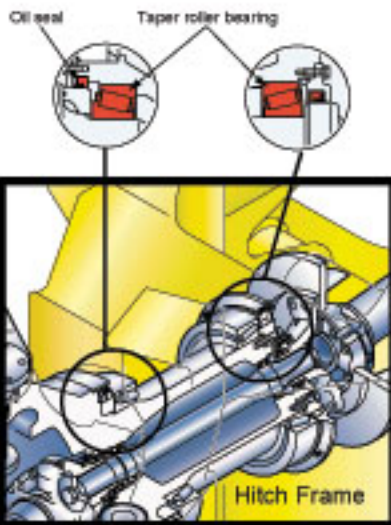

Fewer Grease Points

The number of grease points are minimized by using maintenance-free rubber bushings and a maintenance-free oscillating hitch.

Extended Service Intervals

In order to minimize operating costs, service intervals have been extended:

- Engine oil 500 hours
- Transmission oil 1000 hours
- Engine and transmission filters 500 hours

Guards

The following guards are provided as standard:

- Protective grille for rear window
- Engine underguard
- Transmission underguard
- Propeller shaft guards
- Exhaust thermal guard
- Fire wall covers



SPECIFICATIONS



ENGINE

Model	Komatsu SAA6D125E-3
Type	Water-cooled, 4-cycle
Aspiration	Turbo-charged and air-to-air after-cooled
Number of cylinders	6
Bore	125 mm 4.92"
Stroke	150 mm 5.91"
Piston displacement	11.04 ltr 674 in ³
Performance:	
Gross horsepower	250 kW 335 HP
Flywheel horsepower	242 kW 324 HP
Rated rpm	2000 rpm
Maximum torque	160 kg·m 1,157 lb. ft
Fuel system	Direct injection
Governor	Electronically controlled
Lubrication system	
Method	Gear pump, force-lubrication
Filter	Full-flow type
Air cleaner	Dry type with double elements and precleaner (cyclopack type), plus dust indicator



TRANSMISSION

Torque converter	3-elements, 1-stage, 2-phase
Transmission	Full-automatic, counter-shaft type
Speed range	8 speeds forward and 2 reverse
Lockup clutch	Wet, single-disc clutch
Forward	Torque converter drive in 1st gear, direct drive in 1st lockup and all higher gears
Reverse	Torque converter drive and direct drive in all gear
Shift control	Electronic shift control with automatic clutch modulation in all gear
Maximum travel speed	59.0 km/h 36.7 mph



AXLES

Full time all wheel drive with limited slip differential in all axles.	
Final drive type	Planetary gear
Ratios:	
Differential	3.154
Planetary	4.667



SUSPENSION SYSTEM

Front	Hydro-pneumatic suspension
Rear	Combined hydro-pneumatic and rubber suspension system



STEERING SYSTEM

Type	Articulated type, fully hydraulic power steering with two double-acting cylinders
Supplementary steering	Automatically actuated, electrically powered
Minimum turning radius, wall to wall	7.96 m 26'1"
Articulation angle	45° each direction



BRAKES

Service brakes	Full-hydraulic control, oil-cooled multiple-disc type
Parking brake	Spring applied, caliper disc type
Retarder	Front and center axle brakes act as retarder



MAIN FRAME

Type	Articulated type, box-sectioned construction on front and rear
------	--



BODY

Capacity:	
Struck	12.9 m ³ 16.9 yd ³
Heaped (2:1, SAE)	16.6 m ³ 21.7 yd ³
Payload	27.3 metric tons 30.1 U.S. tons
Material	130 kg/mm ² 184,825 psi high tensile strength steel
Material thickness:	
Bottom	14 mm 0.55"
Front	8 mm 0.31"
Sides	12 mm 0.47"
Target area	
(in side length x width)	5240 mm x 2685 mm 17'2" x 8'10"
Heating	Exhaust heating (optional)



HYDRAULIC SYSTEM

Hoist cylinder	Twin, 2-stage telescopic type
Relief pressure	20.6 Mpa 210 kg/cm ² 2,990 psi
Hoist time	12 sec



CAB

Dimensions comply with ISO 3471 and SAE J1040-1988c ROPS (Roll-Over Protective Structure) standards



WEIGHT (APPROXIMATE)

Empty weight	22500 kg 49,600 lb
Gross vehicle weight	49875 kg 108,960 lb
Weight distribution:	
Empty: Front axle	58.8%
Center axle	22.2%
Rear axles	21.0%
Loaded: Front axle	29.8%
Center axle	35.7%
Rear axles	34.5%



TIRES

Standard tire	23.5 R25
---------------	----------



SERVICE REFILL CAPACITIES

Fuel tank	382 ltr. 100.9 U.S. Gal
Engine oil	35 ltr. 9.2 U.S. Gal
Torque converter, transmission and retarder cooling	77.5 ltr. 20.5 U.S. Gal
Differentials (total)	50 ltr. 13.2 U.S. Gal
Final drives (total)	13.5 ltr. 3.6 U.S. Gal
Hydraulic system	120 ltr. 31.7 U.S. Gal
Suspension (total)	10.4 ltr. 2.7 U.S. Gal



DIMENSIONS

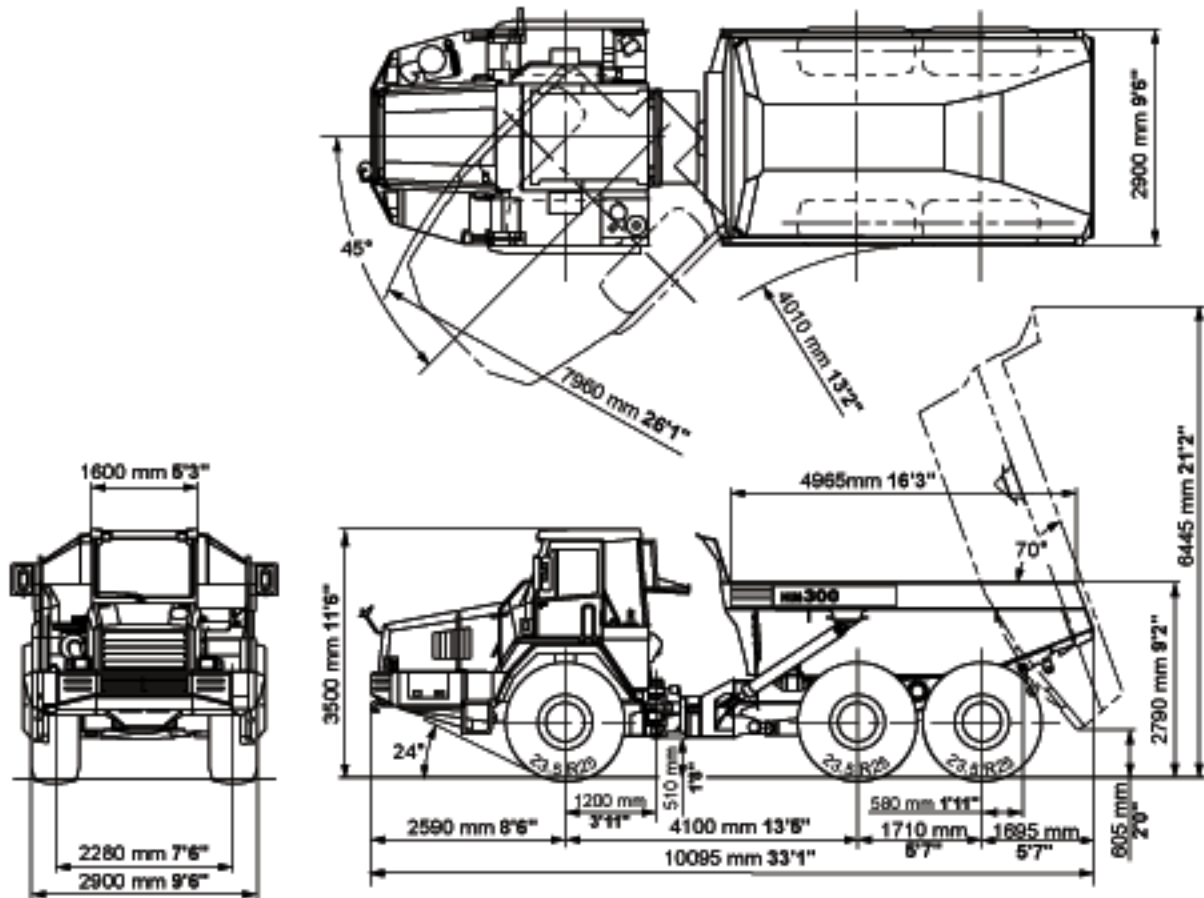

TRAVEL PERFORMANCE

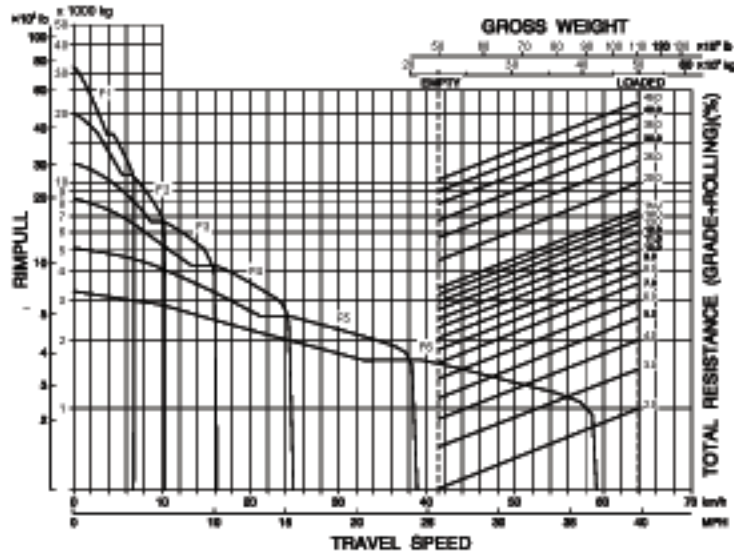

BRAKE PERFORMANCE

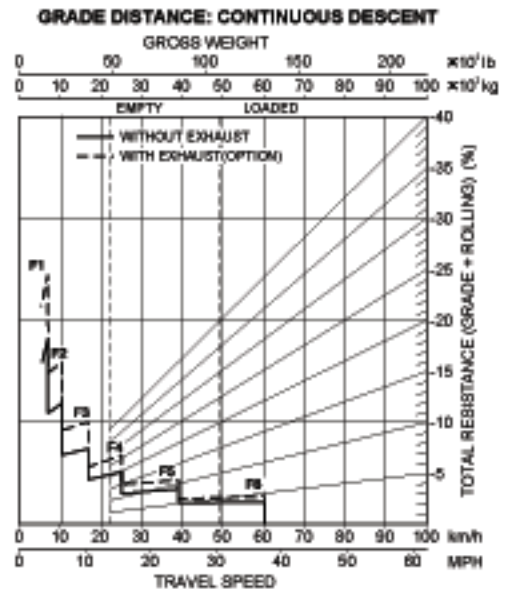



STANDARD EQUIPMENT FOR BASE MACHINE

ENGINE:

- Alternator, 50A/24V
- Air cleaner, dry type with double elements and precleaner, plus dust indicator
- Batteries, 170 Ah/2 x 12V
- Electric governor
- Engine, Komatsu SAA6D125E-3, turbo-charged and air to air aftercooled, high pressure common rail injection system, 2001 USA Tier II EPA-certified, diesel
- Exhaust muffler with stack
- Fuel/water separator
- Full-automatic F8 R2 transmission with K-ATOMIC shift control and automatic T/C lockup
- Starting motor, 11.0 kW
- Switch for power or economy setting

CAB:

- 12 volt outlet port
- Air conditioner/heater/defroster, electronically controlled
- Ashtray and cigarette lighter
- Cup holder
- Dual entry
- Electronic hoist control system
- Electronic maintenance display/monitoring system
- Floor mat
- Power windows
- Radio AM/FM with cassette
- Rear window guard
- ROPS cab with FOPS, sound suppression type (76 dBA) with viscous cab

mounts

- Seat, air suspension, reclining (fabric)
- Seat, passenger, with 3" seat belt
- Seat belt, operator's, 3" width, retractable
- Storage space under seat and right arm-rest
- Sun visor, front window
- Tilt and telescopic steering wheel
- Tilt cab arrangement for easy service-ability
- Tinted glass
- Windshield washer and wiper (front and rear)

LIGHTING SYSTEM:

- Back-up light
- Hazard light system
- Headlights with dimmer switch
- Stop, tail and turn signal lights
- Working lights, front

GUARD AND COVERS:

- Engine oil pan
- Driveline guards, front and rear
- Transmission underguard
- Mudguards for front and rear tires
- Exhaust/muffler thermal guard

MONITORING SYSTEM:

- Instrument panel (digital display with service meter and odometer, fuel gauge, speedometer, tachometer, coolant temperature, torque converter oil temperature, retarder oil temperature)

- Warning light and alarm system (parking brake, dump body float, fuel, secondary steering, coolant temperature, torque converter oil temperature, retarder oil temperature, battery charge, steering oil temperature, engine oil pressure, retarder oil pressure, tilt caution, engine system, transmission system, retarder system)

OTHER STANDARD EQUIPMENT:

- Alarm, backup
- Body, 16.6 m³ 21.7 yd³
- Centralized greasing
- Limited slip type differential in all axles
- Electric circuit breaker, 24 volt
- Electronic hoist control system
- Hand rails for platform
- Horn, electric
- Hydropneumatic suspension, front and rear
- Interaxle lockup, clutch type
- Ladders, left and right hand side
- Rearview mirrors
- Rearview mirrors, additional, left and right hand side
- Retarder/brake system, continuously cooled
- Steering system, auxiliary, automatic electric
- Tire, 23.5R25 Bridgestone VLT with rims
- Under view mirror, front



OPTIONAL EQUIPMENT

BODY:

- Delete body
- Body exhaust heating kit
- Tail gate

LIGHTING SYSTEM:

- Fog lights
- Side working lights, left and right side

OTHER:

- Alternator, 75A, 24V
- Batteries, large capacity

TIRES:

- 23.5R25 XADN E3 Michelin
- 23.5R25 RL-2+E2 Goodyear
- 750/65R25 RL-2+2 Star 4S TL

SUPPORT

Count on Komatsu and your local distributor for the support you deserve. Our success depends on satisfying your need for productive equipment and supporting that equipment. That's why we have one of the largest and strongest heavy-equipment distributor organizations in North America. Their personnel are not only trained to help you select the equipment that is best-matched for your business but to support that equipment.



Finance Through its finance company, Komatsu can offer you a wide variety of financing alternatives designed to meet your needs. Programs include municipal leases for governmental agencies, conditional sales contracts, and leases with \$1 purchase options for customers interested in owning their equipment. Ask your distributor about Komatsu leasing. We offer finance and operating leases and the unique *Advantage Lease* which offers you predetermined purchase, return, and renewal options.



Parts Three computer-linked parts distribution centers provide fast access to anywhere in the U.S. and Canada. Most parts are available overnight. Plus, Komatsu distributors keep a large assortment of commonly used parts in stock for immediate access.



Remanufactured parts Save money and still have the same warranty as new parts at a fraction of the cost with like-new remanufactured parts.



Maintenance Take advantage of the experience we have gained and ask your distributor about our factory-supported programs including: regular scheduled maintenance, oil and wear analysis, diagnostic inspections, undercarriage inspections, training, special service tools, parts programs, and even a special software program to help your distributor keep track of and manage service-related data.

KOMATSU

Komatsu America
440 N. Fairway Dr.
Vernon Hills, IL 60061

