

normet

Normet Corporation
Ahmolantie 6
FI-74510 IISALMI, FINLAND
Tel +358 (0) 17 83 241
Fax +358 (0) 17 823 606

Utimec 1090 D

Rock hauler

TI 100009037
DRW
DATE 07.07.2009
PAGE 1 / 3
APPR. 07.07.2009

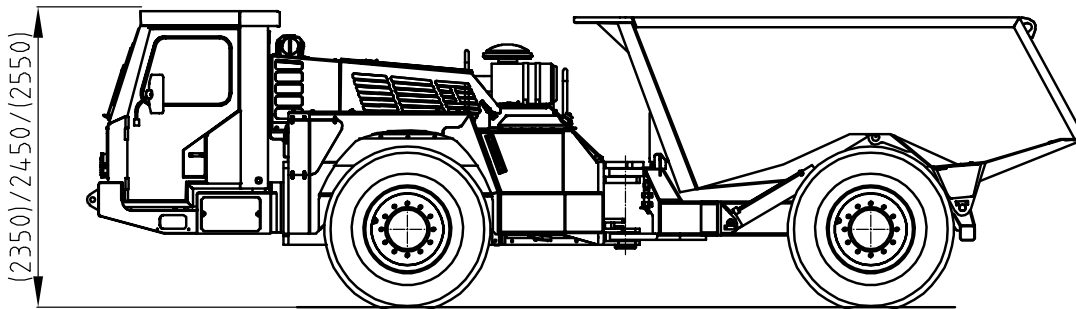
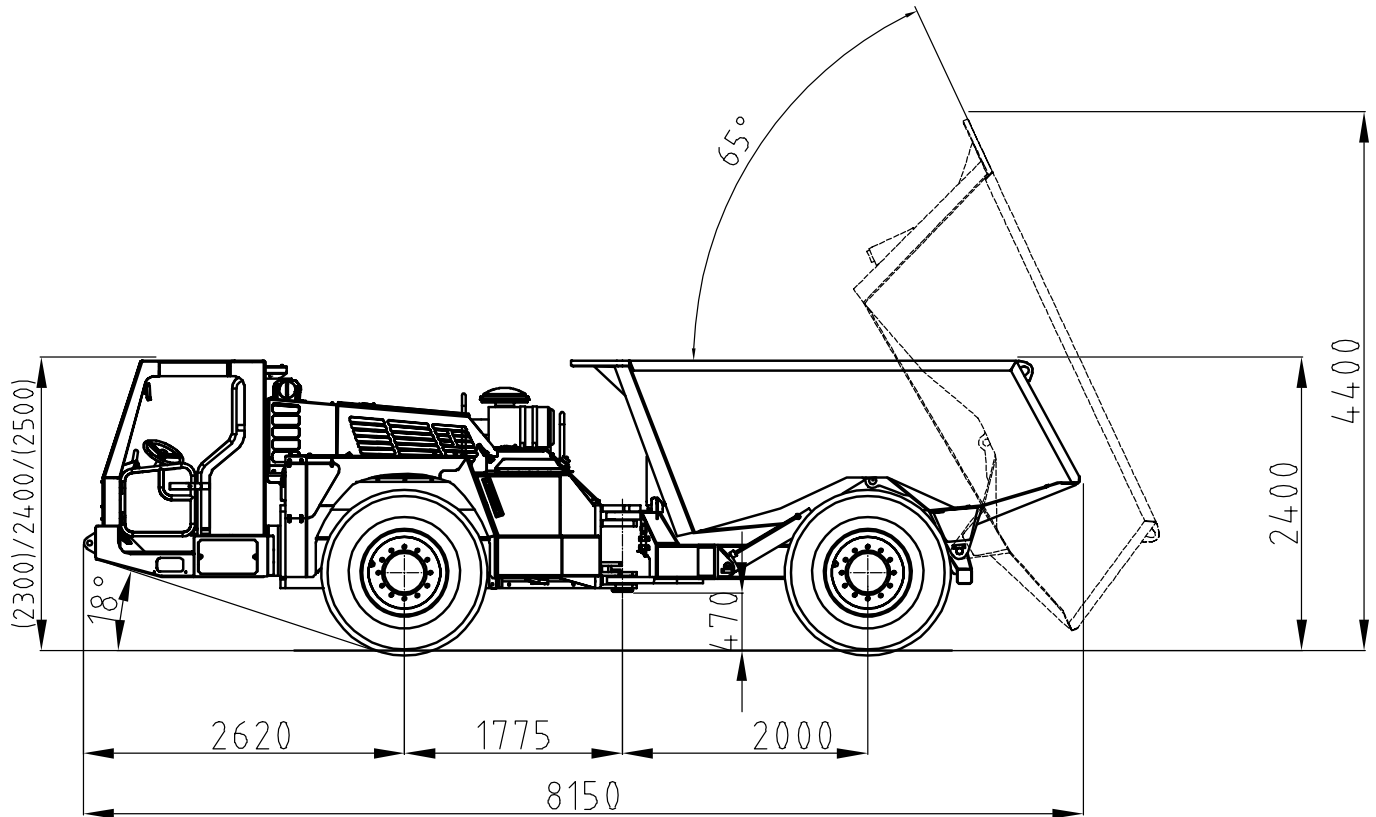

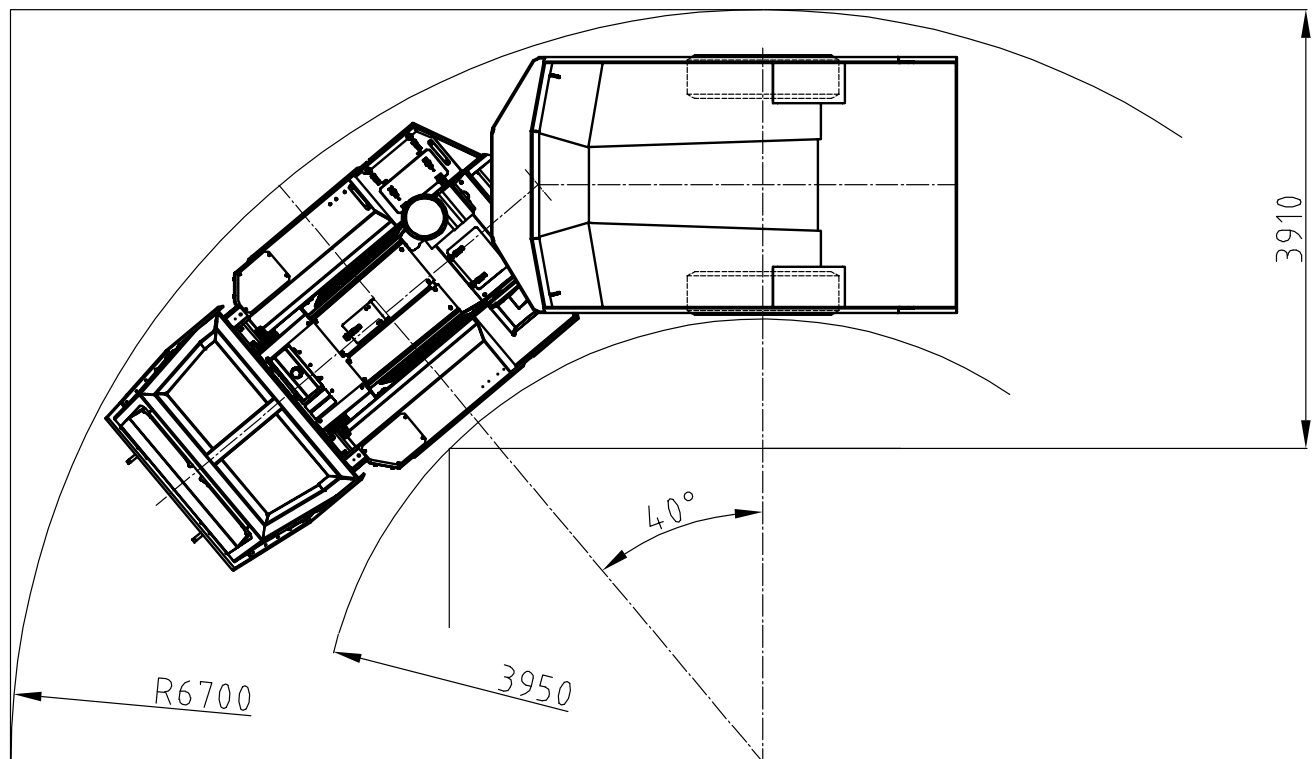
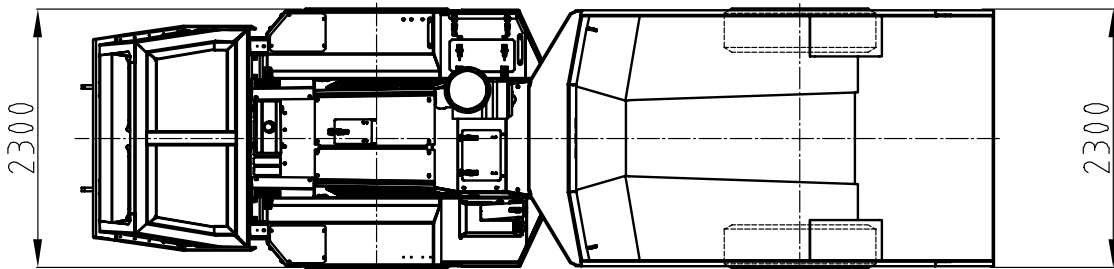

DIMENSIONS

Length	8150 mm
Width	2300 mm
Height	(+/- 100 mm) 2400 mm
Wheel base	3775 mm
Track	1950 mm
Ground clearance	470 mm

WEIGHT

Operating	13000 kg
-----------	----------

TURNING RADIUS

Outer	6700 mm
Inner	3950 mm

DUMP PUCKET

Volume	9 m ³
Maximum payload	16000 kg
Tipping angle	65°
Tipping height	4400 mm

PERFORMANCE CURVE

1st gear	max. 5 km/h
2nd gear	10 km/h
3rd gear	18 km/h
Max. tractive effort	165 kN

TRANSMISSION

Dana Spicer powershift
 3 speeds forwards and reverse
 4-wheel drive

AXLES

Planetary type	
rear axle fixed	
front axle oscillation	+/- 7°

TYRES

14.00 - 24 PR 24

BRAKES

Service brake: hydraulically powered two-circuit oil immersed multidisc brakes in both axles

Safety/Parking brake: hydraulically released fail-safe - type brake

STEERING

Hydraulic frame steering, Orbitrol type	
Frame articulation	+/- 40°

HYDRAULICS

190 bar, 100 l/min/2200 rpm
 for steering and brakes

ENGINE

Deutz TCD 2012 L6
 155 kW/2300 rpm

ELECTRICAL SYSTEM

24 V negative ground	
Battery	2 x 110 Ah
Alternator	80 A
Lights	(2+2) x 70 W

OPTIONS AND ACCESSORIES:**ENCLOSED CABIN**

Height	(+/- 100 mm) 2450 mm
--------	----------------------

CABIN HEATING**AIR CONDITIONING****ENGINE**

MB OM 906 LA
 170 KW/2200 rpm

RETARDER

Mounted in driveline
 Electromagnetic type
 Recommended on inclines deeper than 1:10 and longer than 1000 m