

from

The Underground Experts

TORO 50

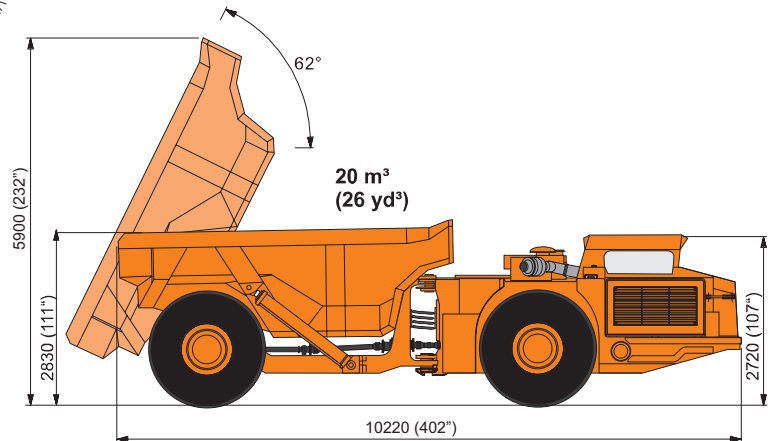
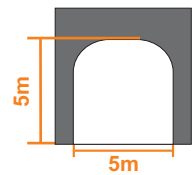
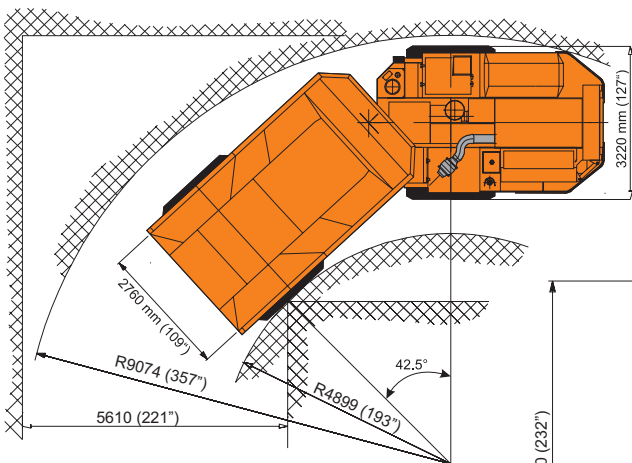

KEY SPECIFICATIONS

Capacity

Payload capacity
Box range (SAE 2:1) 50 000 kg (110 232 lb)
19 m³ - 28 m³
(25 yd³ - 37 yd³)

Weights

Operating weight 32 500 kg (71 650 lb)
Total loaded weight 82 500 kg (181 880 lb)

Dimensions

Total length 10 220 mm (402")
Total width 3 220 mm (127")
Height 2 720 mm (107")
Max height of the box 2 960 mm (117")
Ground clearance 500 mm (20")
Tunnel size
(depends on local regulations) 5 m x 5 m

COMPONENTS AND OPTIONS

Major Components

Diesel engine	Detroit S-60 DDEC IV
Engine output	392 kW (525 bhp) / 2100 rpm
Gearbox	Dana SOH 8821
Axles	Dana SOH 21D 4354
Front axle oscillation	±13°
Tyres, size & type	29.5R25 Bridgestone VSNT E/L-4

Main options

ROPS/FOPS safety cabin with air cond. and stereos
Automatic central lubrication
Posi-stop brakes
Auto engine shut down
Load weighing system
Electrical retarder TELMA
Exhaust brake "Jake Brake"
Fire suppression system ANSUL
Shiftronics automatic gear shifting, lock up
Accordance with CE-norms

Sandvik Mining and Construction has the market's most comprehensive product portfolio for rock and mineral excavation and demolition operations in mining and civil engineering.

TORO 50

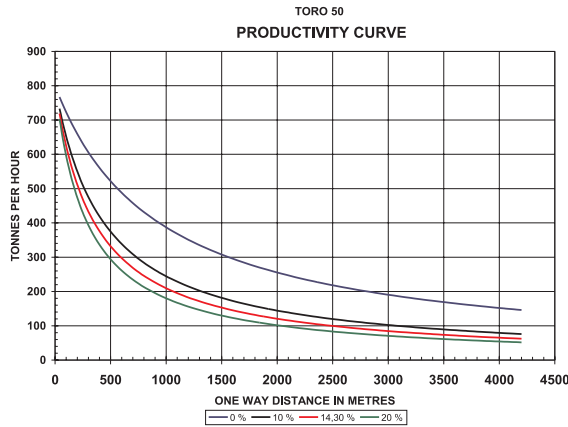

Basic data for calculations:

Payload 50 000 kg
Overall speed limit 30 km/h
Fixed cycle time 3,75 min
Rolling resistance 3 %

Fixed cycle time includes the time for filling, dumping, turning and accelerating

Slope / Grade (%)	Hor./0	1:10/10	1:7/15	1:5/20
Loaded speed (km/h)	30	9,2	7	5,5
Empty speed (km/h)	30	30	30	30

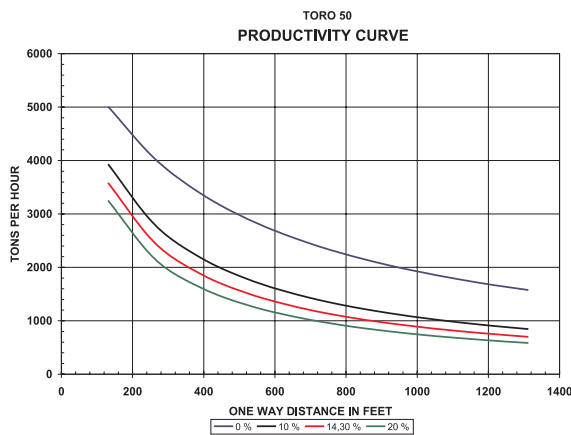

Basic data for calculations:

Payload 110 231 lbs
Overall speed limit 18,6 mph
Fixed cycle time 0,5 min
Rolling resistance 3 %

Fixed cycle time includes the time for filling, dumping, turning and accelerating

Slope / Grade (%)	Hor./0	1:10/10	1:7/15	1:5/20
Loaded speed (mph)	18,6	5,7	4,3	3,4
Empty speed (mph)	18,6	18,6	18,6	18,6

High Productivity

- High capacity / own weight
- Small envelope size
- High availability



Safety

- Built in safety features to protect the operator and the machine

Operator comfort

- Comfortable working environment
- Easy daily maintenance

TORO

Sandvik Tamrock Corp., TORO Loaders, P.O Box 434, FIN-20101, Turku, Finland
Tel. +358 205 44 131. Fax. +358 205 44 130. E-mail: toro@sandvik.com
www.toro.sandvik.com