

VOLVO WHEEL LOADERS

L250G

33,4-35,4 t 395 hp



A PASSION FOR PERFORMANCE.

At Volvo Construction Equipment, we're not just coming along for the ride. Developing products and services that raise productivity – we are confident we can lower costs and increase profits for industry experts. Part of the Volvo Group, we are passionate about innovative solutions to help you work smarter – not harder.

Helping you to do more

Doing more with less is a trademark of Volvo Construction Equipment. High productivity has long been married to low energy consumption, ease of use and durability. When it comes to lowering life-cycle costs, Volvo is in a class of its own.

Designed to fit your needs

There is a lot riding on creating solutions that are suited to the particular needs of different industry applications. Innovation often involves high technology – but it doesn't always have to. Some of our best ideas have been simple, based on a clear and deep understanding of our customers' working lives.



You learn a lot in 175 years

Over the years, Volvo has advanced solutions that have revolutionized the use of construction equipment. No other name speaks Safety louder than Volvo. Protecting operators, those around them and minimizing our environmental impact are traditional values that continue to shape our product design philosophy.

We're on your side

We back the Volvo brand with the best people. Volvo is truly a global enterprise, one that is on standby to support customers quickly and efficiently – wherever they are.

We have a passion for performance.



Volvo Trucks

Renault Trucks

Mack Trucks



UD Trucks



Volvo Buses



Volvo Construction Equipment



Volvo Penta



Volvo Aero



Volvo Financial Services

DOUBLE YOUR PRODUCTIVITY WITH EVERY LOAD.

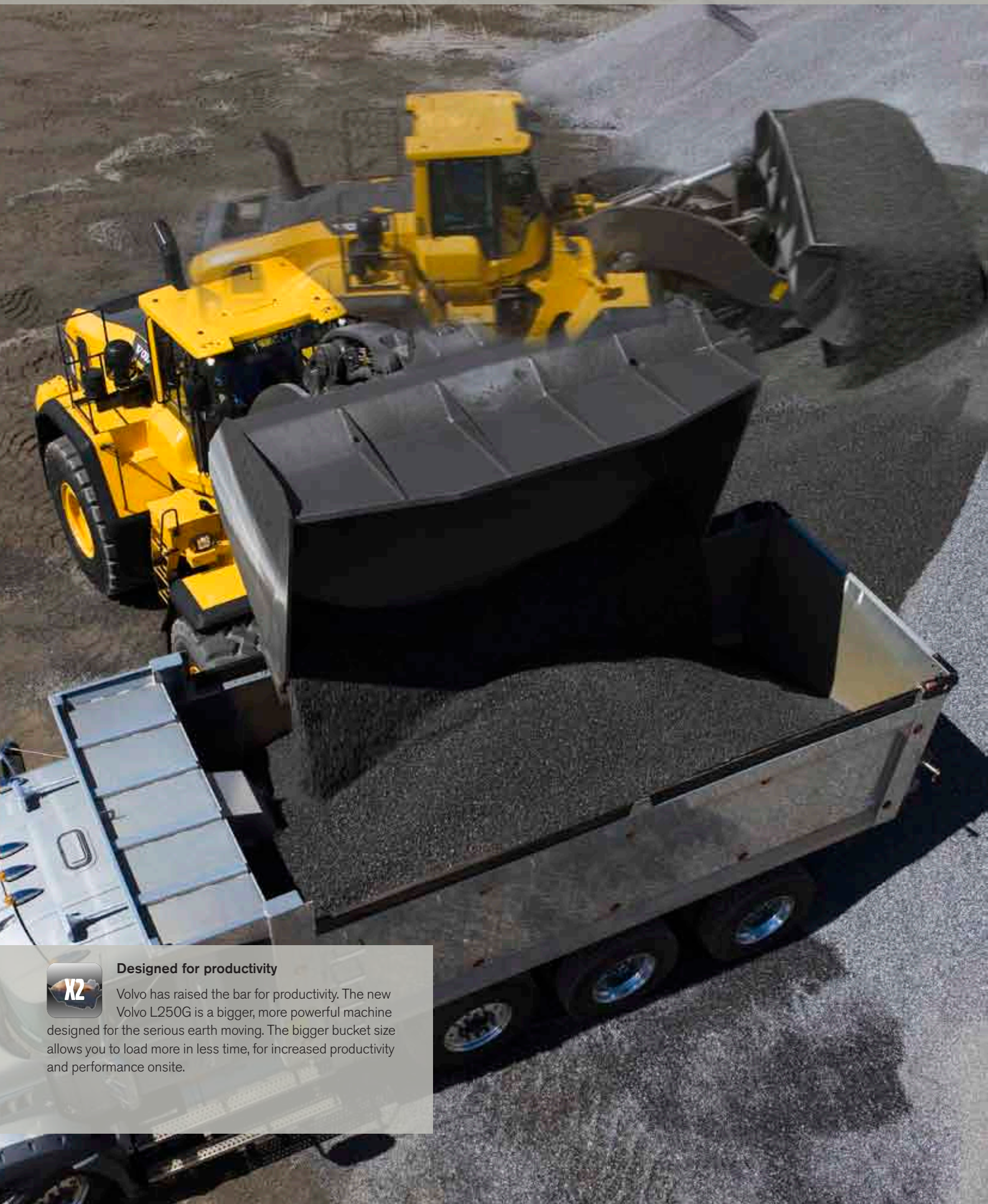

Designed for productivity

Volvo has raised the bar for productivity. The new Volvo L250G is a bigger, more powerful machine designed for the serious earth moving. The bigger bucket size allows you to load more in less time, for increased productivity and performance onsite.

Volvo understands that in tough work environments, machines need to perform. That's why the Volvo L250G is purpose-built with more power and a bigger bucket size to optimize each load for increased productivity and profitability. The new L250G is in a league of its own, allowing you to load-up in less time.



Z-bar linkage

Volvo's Z-bar linkage provides high breakout force to enable stronger, more powerful digging of hard materials. With a high-lift capacity, fully loaded buckets can be elevated to a maximum height. Fast hydraulic speeds enable quick load cycles for faster production, even in the toughest working environments.

Load-sensing hydraulics

Stronger lift and tilt functions are achieved by new Volvo variable-flow axial piston pumps, with high pump capacity for superior control of the load and attachments. Load-sensing hydraulics match power when it's needed for lower fuel consumption and high performance. Hydraulic pumps are optimally matched to the engine and drivetrain for fast, precise movements and high breakout force at low speeds.

MORE POWER, LESS WASTE.

Volvo prides itself on producing fuel efficient machines: machines that give you more power while consuming less fuel. The Volvo L250G is no exception; refined features give you the most efficient operation possible to save you time and money – without harming the environment.



Engine performance

Volvo's efficient 13 litre, 6-cylinder turbocharged diesel engine gives you more power, while consuming less fuel, enabling high torque at low engine speeds. Low emission levels meet exhaust cleaning requirements for ultimate efficiency and environmental care.

Diesel Particulate Filter with regeneration

The active-type Diesel Particulate Filter (DPF) includes a regeneration burner. The system temporarily holds the exhaust and then incinerates it, further reducing hydrocarbon / carbon emissions. Process results in no loss of operation or performance.

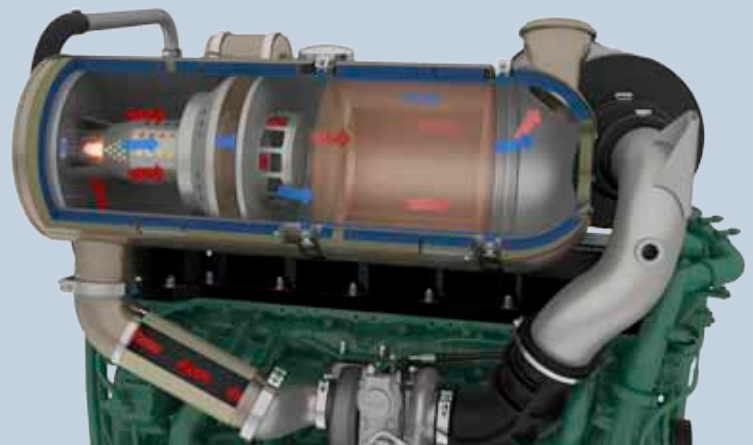

Productive Optishift

OptiShift includes the torque converter with the unique Volvo Lock-Up and Reverse By Brake systems – applies standard service brake instead of the torque converter. The result is faster loading cycles and incline climbing performance, even during deceleration.



Automatic Power Shift

Automatic Power Shift allows the machine to operate in the best gear according to speed, kick down and engine braking. Fully Automatic Power Shift (FAPS) automatically switches to 1st gear when additional power is needed for lower fuel consumption.

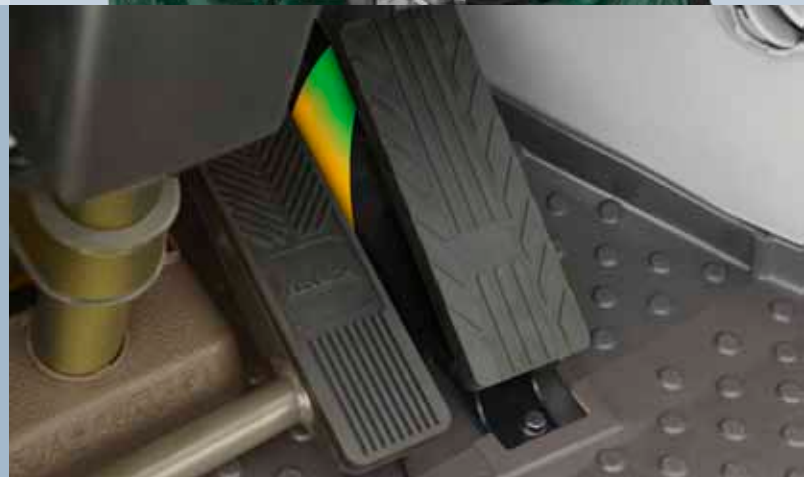

Eco pedal

The eco pedal encourages the operator to engage the throttle pedal with ease to lower fuel consumption, by applying the appropriate amount of mechanical counter pressure (push-back). This economical pedal feature promotes operator efficiency by avoiding excessive fuel use.



Purpose-built drivetrain

Solely designed and manufactured by Volvo, the engine, transmission, axles, hydraulics and steering are developed as one unit to provide optimized performance, lower fuel consumption and maximum reliability for long machine life.

POWER THAT LASTS: DAY IN, DAY OUT.



New design

The new engine hood can be electronically opened backwards for easy access and fast maintenance/cleaning. Large ventilation sections keep the engine cool for sustained performance and a wide opening angle allows for a better overview of the full engine compartment.

Strength and durability are at the heart of the Volvo 250G. A new engine hood design and computerized monitoring system are just some of the maintenance-saving features to help you work for longer and sustain optimum power and productivity day in and day out. Volvo won't let you down.

Problem-solving contronics

Volvo contronics is a computerized system that continuously monitors the machine's operation and performance in real time, so you don't have to. Contronics relays necessary diagnostics to the operator via a screen. The information panel provides warning messages so problems can be found early to reduce down-time and improve safety.

Stage IIIB / Tier 4 Interim engine

Volvo's 13 litre, 6-cylinder turbocharged diesel engine is efficient and environmentally responsible, with low emission levels that meet Stage IIIB / Tier 4 Interim engine requirements. Fuel consumption is lowered by a high pressure unit injector system, cooled exhaust, gas recirculation and particulate filter with active regeneration. High torque at low engine speeds is still achieved for industry-leading performance.



Rear axle cradles

The rear axle cradles are maintenance free. Rear-axle bridge connects the axle to the frame and includes two grease-lubricated-for-life roller bearings. Front bridge includes two oil bath, pre-filled-for-life bushings. Minimizes force on the axle and helps to maintain a low centre of gravity. Cradle oscillation pins are sealed to keep grease/oil in and dirt out for easy maintenance.

Heavy duty axles

Volvo's heavy-duty wet brake axles promote a longer service life. Axle housings absorb all loads from the machine weight distribution, so the axle shafts only transmit torque to the hub reductions, which reduces working stresses on the propeller and axle shafts.

PRECISION AT YOUR FINGERTIPS.

As every operator knows, space matters – particularly the one in your cab. Volvo provides a premium operator environment with excellent visibility, ample room and easy-access controls. In the safe, quiet space, operators feel focused, efficient and in control – every time they work.

Air filter

Take a deep breath; Volvo provides a world-class cab climate. The cab air intake is placed in a prime location – high in the cab, where the air is cleaner and further from outside dust. The easy-to-replace pre-filter separates coarse dust. Then 90% of the cab air is circulated through the main filter, giving the operator a breath of fresh air.

Electro Hydraulic Servo Control

The servo controls are mounted on the operator seat, to keep them in place despite seat movement. The high quality controls allow the selection of easy settings from inside the cab such as: return to dig and boom and tilt detent.



Noise reduction

Inside is quieter than outside, thanks to noise and vibration dampening inside the cab. Another great idea from Volvo.



Climate control

No matter what the weather does, Volvo keeps the operator at a pre-selected temperature with its in-cab climate control system. Select between Automatic Heat Control (AHC) or optional Air Conditioning (AC) to keep operators focused and productive.



Industry-leading cab

The Volvo cab is industry-tested and approved according to ROPS/FOPS. Safety is at the forefront of design alongside excellent all-round visibility. The cab is spacious allowing ample room to stretch out your legs and still have room for storage.

LOADED WITH INNOVATION.

Eco pedal

Mechanical counter pressure encourages fuel-saving with the accelerator pedal.



Industry-leading cab

Roomy, ROPS/FOPS tested cab with conveniently-placed controls and industry-leading air filter.



Engine

Volvo's efficient 13 litre, 6-cylinder turbocharged diesel engine gives you more power, while consuming less fuel.



New design

New electronic opening design for easy service access. Bigger ventilation panels keep the engine cool.

Heavy-duty axles

Absorb the weight for optimal torque, reduced stresses and longer life.

Automatic Power Shift

The machine always operates in the most suitable gear according to speed, kick down and engine braking to save fuel consumption.

Electro servo controls

Mounted on the cab seat for comfortable operation and control.





Designed for productivity

The new Volvo L250G has a bigger bucket size allowing you to load-up in less time, for better productivity and performance.



CareTrack*

Standard telematics to remotely guide machine owners towards optimized productivity and their next service.



Purpose built drivetrain

Engine, transmission, axles, hydraulics and steering are developed as one unit by Volvo to provide optimized performance and maximum reliability.

Load-sensing hydraulics

Variable-flow axial piston pumps for superior control and high breakout force.



Z-bar linkage

High breakout force for strong, powerful digging of hard materials maintained to highest-lift capacity.

Productive Optishift

Includes torque converter with Lock-Up and Reverse By Brake for lower fuel consumption in most applications.

* In markets where CareTrack is available

TOP PERFORMANCE DESERVES SUPPORT.

The day you receive your new Volvo Wheel Loader is just the start of your working relationship with Volvo. From service and maintenance to our CareTrack telematics system – Volvo has a comprehensive and sophisticated aftermarket portfolio to continuously add value to your business.

Volvo designed and built your machines, so no-one knows how to keep them working in top condition more than us. When it comes to your machine, our Volvo trained technicians are the experts.

Our technicians work with industry leading diagnostic tools and techniques, using only Genuine Volvo Parts to deliver the highest levels of quality and service. Talk to your Volvo dealer about how genuine Volvo services can best provide the service and maintenance plan that is the right fit for you and your business.



State-of-the-art machines require state-of-the-art support and your Volvo dealer can provide a catalogue of services designed to get the most out of your machine, helping you maximise uptime, productivity and residual value. Your Volvo dealer can provide a number of sophisticated support offers, including:

Service plans ranging from routine wear inspections, through to comprehensive maintenance and repair agreements.

Analysis and diagnostics to help you understand how your machine is running, highlight potential maintenance issues and identify where performance can be improved.

Eco Operator training courses can help your operators work towards a safer, more productive and fuel efficient performance.



CareTrack*

Each Volvo Wheel Loader comes standard equipped with CareTrack, the Volvo telematics system. CareTrack provides information for better planning and smarter working; including fuel consumption reports, location reports and service reminders. Save fuel. Reduce costs. Maximise profitability. You can with CareTrack.

* In markets where CareTrack is available

CONNECT AND GO.

All genuine Volvo attachments are purpose-built with the same quality as the rest of the machine. They're designed as an integrated part of the wheel loader for which they were intended, their functions and properties perfectly matched to parameters such as link-arm geometry and breakout, rim pull and lifting force. That's why the machine and attachment work in perfect harmony, forming a dependable cohesive unit to get the job done – safely and efficiently.

Rehandling buckets increase fuel efficiency:

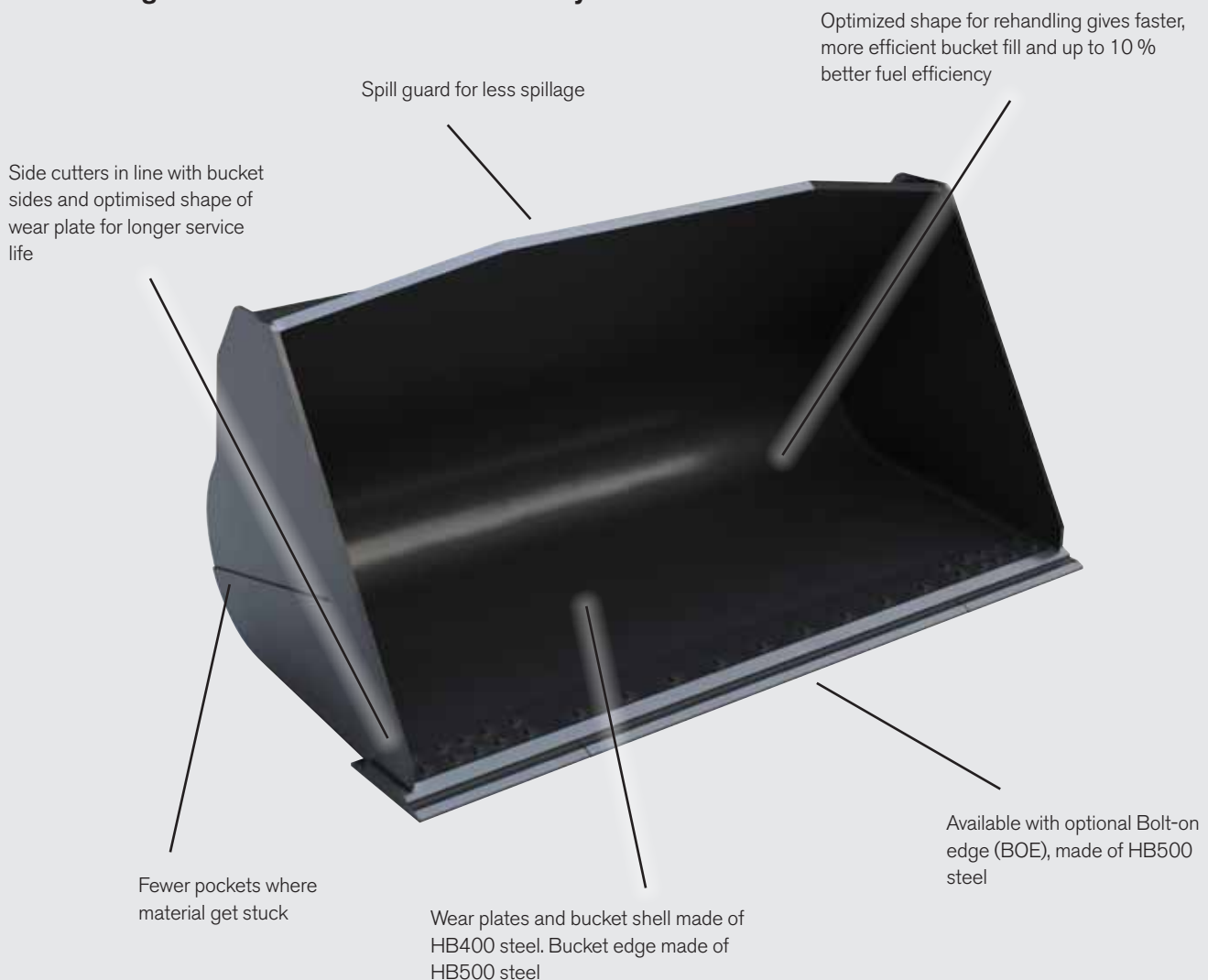

Volvo Tooth system

The Volvo patented vertical locking device makes mounting and removing fast and easy. For Volvo buckets there are a also wide selection of cutting edges and segments in high strength steel 500 HB to protect the bucket from wear.



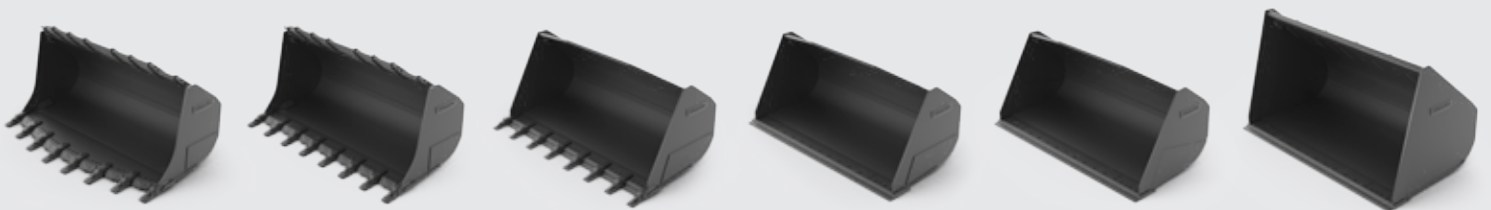

VOLVO L250G IN DETAIL.



Engine

V-ACT Stage III B/Tier 4i, 13 liter, 6-cylinder straight turbocharged diesel engine with 4 valves per cylinder, overhead camshaft and electronically controlled unit injectors. The engine has wet replaceable cylinder liners and replaceable valve guides and valve seats. The throttle applications is transmitted electrically from the throttle pedal or the optional hand throttle. **Air cleaning:** Three-stage Cyclone precleaner - primary filter -secondary filter. **Cooling system:** Hydrostatic, electronically controlled fan and intercooler of the air-to-air type.

Engine		D13H-E D13H-F
Max power at	r/s (r/min)	25,0 (1500)
SAE J1995 gross	kW / hp	291 (395)
ISO 9249, SAE J1349 net	kW / hp	290 (394)
Max torque at	r/s (r/min)	18,3 (1100)
SAE J1995 gross	Nm	2231
ISO 9249, SAE J1349 net	Nm	2216
Economic working range	r/min	800 - 1600
Displacement	l	12,81

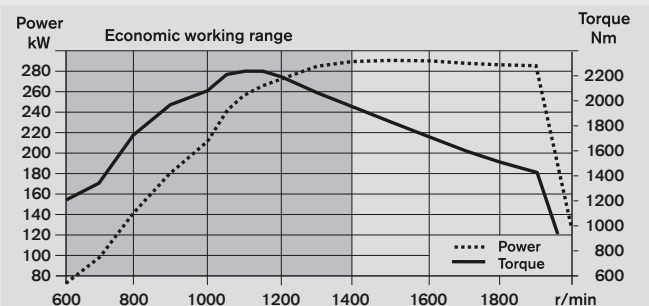

Brake system

Service brake: Volvo dual-circuit system with nitrogen-charged accumulators. Outboard-mounted fully hydraulic operated, fully sealed oil circulation-cooled wet disc brakes. The operator can select automatic declutch of the transmission when braking by a switch on the instrument panel.

Parking brake: Fully sealed, wet multi-disc brake built into the transmission. Applied by spring force, electro-hydraulic release with a switch on the instrument panel.

Secondary brake: Dual brake circuits with rechargeable accumulators. One circuit or the parking brake fulfills all safety requirements.

Standard: The brake system complies with the requirements of ISO 3450.

Number of brake discs per wheel (front)		1
Accumulators	l	2 x 1,0 + 1 x 0,5

Drivetrain

Torque converter: Single-stage.

Transmission: Volvo countershaft transmission with single lever control. Fast and smooth shifting of gears with Pulse Width Modulation (PWM) valve. Torque converter with lockup.

Transmission: Volvo Automatic Power Shift (APS) with fully automatic shifting 1-4 and mode selector with 4 different gear shifting programs, including AUTO.

Axles: Volvo fully floating axle shafts with planetary hub reductions and nodular iron axle housing. Fixed front axle and oscillating rear axle. 100% differential lock on the front axle.

Transmission			Volvo HTL307
Torque multiplication, stall ratio			2,094:1
Maximum speed, forward/reverse	1st gear	km/h	7,0
	2nd gear	km/h	11,5
	3rd gear	km/h	24,5
	4th gear*	km/h	38,0
Measured with tires			29,5R25 L4
Front axle/rear axle			AWB 50B / 41
Rear axle oscillation ±			15 °
Ground clearance at 15° osc.			600 mm

*) limited by ECU

Electrical system

Central warning system: Contronic electrical system with central warning light and buzzer for following functions: - Serious engine fault - Low steering system pressure - Over speed warning engine - Interruption in communication (computer fault) Central warning light and buzzer with the gear engaged for the following functions. - Low engine oil pressure - High engine oil temperature - High charge air temperature - Low coolant level - High coolant temperature - High crank case pressure - Low transmission oil pressure - High transmission oil temperature - Low brake pressure - Engaged parking brake - Fault on brake charging - Low hydraulic oil level - High hydraulic oil temperature - Overspeeding in engaged gear - High brake cooling oil temperature front and rear axles.

Voltage	V	24
Batteries	V	2 x 12
Battery capacity	Ah	2 x 170
Cold cranking capacity, approx	A	1000
Alternator rating	W/A	2280 / 80
Starter motor output	kW	7,0



Cab

Instrumentation: All important information is centrally located in the operator's field of vision. Display for Contronic monitoring system.

Heater and defroster: Heater coil with filtered fresh air and fan with auto and 11 speeds. Defroster vents for all window areas.

Operator's seat: Operator's seat with adjustable suspension and retractable seatbelt. The seat is mounted on a bracket on the rear cab wall and floor. The forces from the retractable seatbelt are absorbed by the seat rails.

Standard: The cab is tested and approved according to ROPS (ISO 3471), FOPS (ISO 3449). The cab meets with requirements according to ISO 6055 (Operator overhead protection - Industrial trucks) and SAE J386 ("Operator Restraint System").

Sound level in cab according to ISO 6396/SAE J2105

LpA	dB(A)	70
External sound level according to ISO 6395/SAE J2104		
LwA	dB(A)	109
Ventilation	m ³ /min	9
Heating capacity	kW	16
Air conditioning (optional)	kW	7,5

Lift arm system

Z-bar

Cylinders lift		2
Cylinder bore	mm	190
Piston rod diameter	mm	100
Stroke	mm	873
Cylinder tilt		1
Cylinder bore	mm	220
Piston rod diameter	mm	120
Stroke	mm	570

Steering system

Steering system: Load-sensing, hydrostatic articulated steering.

System supply: The steering system has priority feed from a load-sensing axial piston pump with variable displacement.

Steering cylinders: Two double-acting cylinders.

Cylinder bore	mm	100
Piston rod diameter	mm	60
Stroke	mm	525
Working pressure	MPa	21,0 ± 0,35
Maximum flow	l/min	202
Maximum articulation	± °	37

Service

Service accessibility: Large, easy-to-open hood covering whole engine department, electrically operated. Fluid filters and component breather air filters promote long service intervals. Possibility to monitor, log and analyze data to facilitate troubleshooting.

Fuel Tank	l	335
Engine coolant	l	46
Hydraulic oil tank	l	226
Transmission oil	l	48
Engine oil	l	50
Axle oil front/rear	l	77 / 71

Hydraulic system

System supply: Two load-sensing axial piston pumps with variable displacement. The steering system always has priority.

Valves: Double-acting 2-spool valve. The main valve is controlled by a 2-spool pilot valve.

Lift function: The valve has three positions; raise, hold and lower position. Inductive/magnetic automatic boom kickout can be switched on and off and is adjustable to any position between maximum reach and full lifting height.

Tilt function: The valve has three functions including rollback, hold and dump. Inductive/magnetic automatic tilt can be adjusted to the desired bucket angle.

Cylinders: Double-acting cylinders for all functions.

Filter: Full flow filtration through 10 micron (absolute) filter cartridge.

Working pressure maximum, pump 1	MPa	29,0 ± 0,5
Flow	l/min	252
at	MPa	10
engine speed	r/s(r/min)	32 (1900)
Working pressure maximum, pump 2	MPa	31,0 ± 0,5
Flow	l/min	202
at	MPa	10
engine speed	r/s(r/min)	32 (1900)
Working pressure maximum, pump 3	MPa	25,0 ± 0,5
Flow	l/min	83
at	MPa	10
engine speed	r/s(r/min)	32 (1900)
Pilot system	MPa	3,2 - 4,0
Cycle times		
Lift	s	7,1
Tilt	s	1,9
Lower, empty	s	4,1
Total cycle time	s	13,1

SPECIFICATIONS.

Tires L250G: 29.5 R25 L4

		Standard boom	Long boom
A	mm	9250	9557
B	mm	7530	7800
C	mm	3750	3750
D	mm	520	520
E	mm	1580	1612
F	mm	3720	3720
F ₁	mm	3610	3610
F ₂	mm	2830	2830
G	mm	2132	2132
H	mm	3290	3693
J	mm	4360	4721
K	mm	4620	4979
L	mm	6340	6695
M	mm	1540	1469
N	mm	2280	2479
O	°	62	62
P	°	47	47
P ₂	°	45	45
R	°	40	43
R ₁	°	48	48
S	°	75	43
S ₁	°	-317	-317
T	mm	108	176
U	mm	540	540
V	mm	3580	3580
X	mm	2400	2400
Y	mm	3160	3160
Z	mm	3920	4127
a ₁	mm	15750	15750
a ₂	mm	7110	7110
a ₃	mm	3950	3950
a ₄	°	37	37



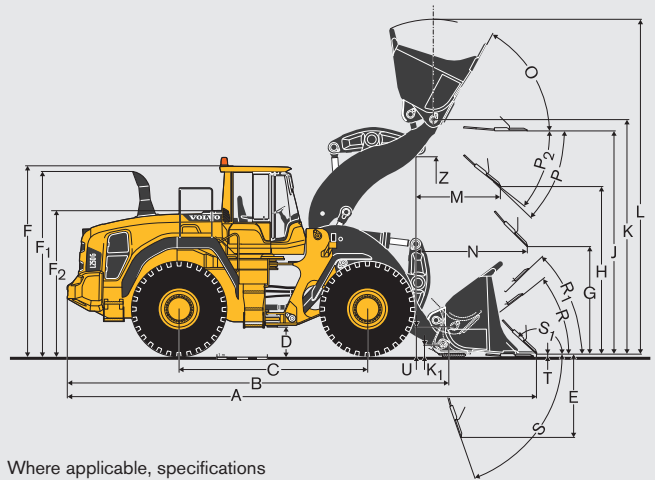



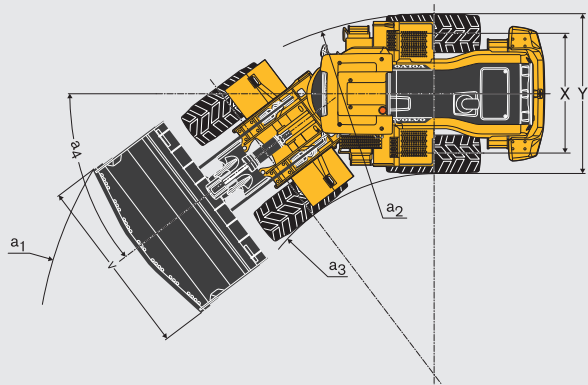

* Carry position SAE



Where applicable, specifications and dimensions are according to ISO 7131, SAE J732, ISO 7546, SAE J742, ISO 14397, SAE J818.



L250G

Tires 29.5 R25 L4	REHANDLING		GENERAL PURPOSE			ROCK*			LIGHT MATERIAL	LONG BOOM	
											
	6,1 m³ STE P BOE	6,9 m³ STE P BOE	5,7 m³ STE P T SEG	6,4 m³ STE P T SEG	6,4 m³ STE P BOE	5,6 m³ STE RO P T SEG	5,5 m³ SPN P T SEG	6 m³ SPN P T SEG	10,2 m³ LM P		
Volume, heaped ISO/SAE	m³	6,1	6,9	5,7	6,4	6,4	5,6	5,5	6,0	10,2	
Volume at 110% fill factor	m³	6,7	7,6	6,3	7,0	7,0	6,2	6,1	6,6	11,2	
Static tipping load, straight	kg	26990	26810	26340	26000	26190	26340	25870	25620	24250	-1430
at 35° turn	kg	23960	23790	23420	23110	23280	23420	22950	22710	21410	-1320
at full turn	kg	23610	23440	23100	22780	22940	23090	22620	22380	21090	-1310
Breakout force	kN	311,3	290,6	320	300	304	336,2	277,4	265,9	251,6	-27
A	mm	9250	9370	9450	9590	9260	9380	9710	9800	9630	310
E	mm	1580	1690	1745	1850	1580	1690	2000	2080	1950	32
H**)	mm	3290	3210	3175	3100	3300	3210	3000	2940	3020	360
L	mm	6340	6460	6350	6460	6460	6680	6670	6760	7010	360
M**)	mm	1540	1620	1660	1730	1540	1620	1860	1910	1820	-70
N**)	mm	2280	2330	2350	2390	2290	2330	2470	2500	2390	220
V	mm	3580	3580	3580	3580	3580	3580	3580	3580	3700	
a1 clearance circle	mm	15750	15800	15850	15900	15760	15820	15990	16030	16060	
Operating weight	kg	34310	34340	34800	34980	34860	34940	35280	35420	34400	780

*) With L5 tires

Note: This only applies to genuine Volvo attachments.

**) Measured to the tip of the bucket teeth or bolt-on edge. Dump height to bucket edge. Measured at 45° dump angle. (Spade nose buckets at 42°)

Bucket Selection Chart

The volume handled varies with the bucket fill and is often greater than indicated by the bucket's ISO/SAE volume. The table shows optimum bucket choice with regard to the material density.

Material	Bucket fill, %	Material density, t/m³
Earth	110 - 115	1,4 - 1,6
Clay	110 - 120	1,4 - 1,6
Sand	100 - 110	1,6 - 1,9
Gravel	100 - 110	1,7 - 1,9
Rock	75 - 100	1,5 - 1,9

The size of rock buckets is optimized for optimal penetration and filling capability rather than the density of the material.

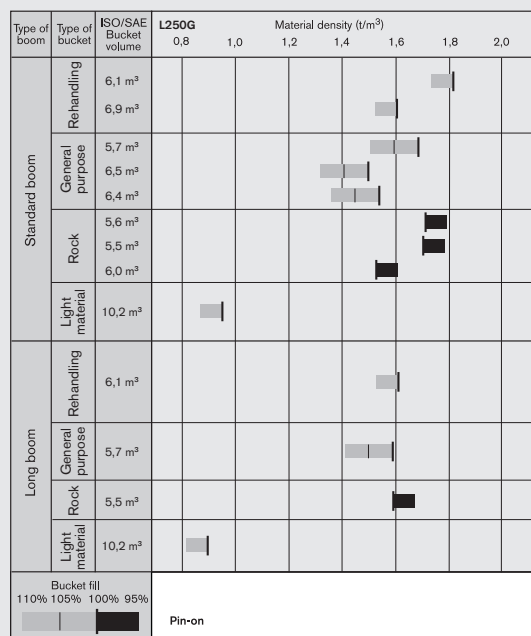

How to read bucket fill factor

Supplemental Operating Data

Tires 29.5 R25 L4	Standard boom		Long boom		
	29.5 R25 L5	875/65R29 L3	29.5 R25 L5	875/65R29 L3	
Width over tires	mm	+35	+95	+35	+95
Ground clearance	mm	+40	-10	+40	-20
Tipping load, full turn	kg	+1010	+180	+930	+180
Operating weight	kg	+1490	+650	+1500	+650

EQUIPMENT.

STANDARD EQUIPMENT

Service and maintenance

- Engine oil remote drain and fill
- Transmission oil remote drain and fill
- Lubrication manifolds, ground accessible
- Pressure check connections: transmission and hydraulic, quick-connects
- Tool box, lockable
- CareTrack
- Telematics, 3-Year Subscription

Engine

- Exhaust after-treatment system
- Three stage air cleaner, pre-cleaner, primary and secondary filter
- Indicator glass for coolant level
- Preheating of induction air
- Fuel pre-filter with water trap
- Fuel filter
- Crankcase breather oil trap
- Exhaust heat insulation
- Exterior radiator air intake protection

Electrical system

- 24 V, pre-wired for optional accessories
- Alternator 24V/ 80A
- Battery disconnect switch with removable key
- Fuel gauge
- Hour meter
- Electric horn
- Instrument cluster:
 - Fuel level
 - Transmission temperature
 - Coolant temperature
 - Instrument lighting
- Lighting:
 - Twin halogen front headlights with high and low beams
 - Parking lights
 - Double brake and tail lights
 - Turn signals with flashing hazard light function
 - Halogen work lights (2 front and 2 rear)

Contronic monitoring system

- Monitoring and logging of machine data
- Contronic display
- Fuel consumption
- Ambient temperature
- Clock
- Test function for warning and indicator lights
- Brake test
- Test function, sound level at max fan speed
- Warning and indicator lights:
 - Battery charging
 - Parking brake
- Warning and display message:
 - Regeneration
 - Engine coolant temperature
 - Charge-air temperature
 - Engine oil temperature
 - Engine oil pressure
 - Transmission oil temperature
 - Transmission oil pressure
 - Hydraulic oil temperature
 - Brake pressure
 - Parking brake applied
 - Brake charging
 - Overspeed at direction change
 - Axle oil temperature
 - Steering pressure
 - Crankcase pressure
 - Attachment lock open
- Level warnings:
 - Fuel level
 - Engine oil level
 - Engine coolant level
 - Transmission oil level
 - Hydraulic oil level
 - Washer fluid level
- Engine torque reduction in case of malfunction indication:
 - High engine coolant temperature
 - High engine oil temperature
 - Low engine oil pressure
 - High crankcase pressure
 - High charge-air temperature

Engine shutdown to idle in case of malfunction indication:

- High transmission oil temperature
 - Slip in transmission clutches
- Keypad, background lit
- Start interlock when gear is engaged

Drivetrain

- Automatic Power Shift
- Fully automatic gearshifting, 1-4
- PWM-controlled gearshifting
- Forward and reverse switch by hydraulic lever console
- Indicator glass for transmission oil level
- Differentials: Front, 100% hydraulic diff lock. Rear, conventional.
- OptiShift

Brake system

- Dual brake circuits
- Dual brake pedals
- Secondary brake system
- Parking brake, electrical-hydraulic
- Brake wear indicators

Cab

- ROPS (ISO 3471), FOPS (ISO 3449)
- Single key kit door/start
- Acoustic inner lining
- Ashtray
- Cigarette lighter, 24 V power outlet
- Lockable door
- Cab heating with fresh air inlet and defroster
- Fresh air inlet with two filters
- Automatic heat control
- Floor mat
- Dual interior lights
- Dual interior rear-view mirrors
- Dual exterior rear-view mirrors
- Sliding window, right side
- Tinted safety glass
- Retractable seatbelt (SAE J386)
- Adjustable steering wheel
- Storage compartment
- Document pocket
- Sun visor
- Beverage holder
- Windshield washer front and rear
- Windshield wipers front and rear
- Interval function for front and rear wipers

Hydraulic system

- Main valve, double acting 2-spool with hydraulic pilots
- Variable displacement axial piston pumps (3) for:
 - 1 Working hydraulic system
 - 2 Working hydraulic system, Steering- and Brake system
 - 3 Cooling fan and Brake system
- Electro-hydraulic servo controls
- Electric level lock
- Boom kick-out, automatic
- Bucket positioner, automatic
- Double-acting hydraulic cylinders
- Indicator glass for hydraulic oil level
- Hydraulic oil cooler

External equipment

- Fenders, front and rear
- Viscous cab mounts
- Rubber engine and transmission mounts
- Easy-to-open engine hood
- Frame, joint lock
- Vandalism lock prepared for
 - Batteries
 - Engine compartment
 - Radiator grille
- Lifting eyes
- Tie-down eyes
- Tow hitch
- Counterweight, pre-drilled for optional guards

Service and maintenance

- Automatic lubrication system
- Automatic lubrication system for long boom
- Grease nipple guards
- Oil sampling valve
- Refill pump for grease to lube system
- Tool kit
- Wheel nut wrench kit

OPTIONAL EQUIPMENT

Engine

Air pre-cleaner, cyclone type
Air pre-cleaner, cyclone type, two-stage
Air pre-cleaner, oil-bath type
Air pre-cleaner, turbo type
Radiator corrosion protection
Engine auto shutdown
Engine block heater 230V/110V
ESW, Disabled engine protection
Air intake protection (for grill in waste)
Fuel fill strainer
Fuel heater
Hand throttle control
Max. fan speed, hot climate
Radiator, corrosion-protected
Reversible cooling fan
Reversible cooling fan and axle oil cooler
Fuel filter, extra

Electrical system

Anti-theft device
Headlights, assym. left
License plate holder, lighting
Rear view camera incl. monitor, colour
Rear-view mirrors, adjustable, el. heated
Rear view mirrors, Long arm
Rear view mirrors, adjustable, el. heated, Long arm
Reduced function working lights, reverse gear activated
Reverse alarm
Reverse warning light, strobe lighting
Shortened headlight support brackets
Rotating beacon
Working lights, attachments
Working lights front, high intensity discharge (HID)
Working lights front, on cab, dual
Working lights front, extra
Working lights rear, on cab
Working lights rear, on cab, dual

Cab

Anchorage for Operator's manual
Automatic Climate Control, ACC
ACC control panel, with Fahrenheit scale
Asbestos dust protection filter
Cab air pre-cleaner, cyclone type
Carbon filter
Cab roof, heavy-duty
Cover plate, under cab
Lunch box holder
Armrest, operator's seat, ISRI, left only
Operator's seat, KAB, air susp, heavy-duty, for CDC and/or elservo
Operator's seat, ISRI, air susp, heat, high back
Radio installation kit incl. 11 amp 12 volt outlet, left side
Radio installation kit incl. 11 amp 12 volt outlet, right side
Radio installation kit incl. 20 amp 12 volt outlet
Radio with CD-player
Seatbelt, 3", (width 75 mm)
Steering wheel knob
Sun blinds, rear windows
Sun blinds, side windows
Timer cab heating
Window, sliding, door
Universal door/ignition key
Front view mirror

Drivetrain

Diff lock front 100%, Limited Slip rear
Speed limiter, 20 km/h
Speed limiter, 30 km/h
Wheel/axle seal guards

Brake system

Oil cooler and filter front & rear axle

Hydraulic system

Boom suspension system
Arctic kit, attachment locking hoses
Arctic kit, pilot hoses and brake accum. incl. hydr. oil
Boom cylinder hose and tube guards
Boom cylinder hose and tube guards for long boom
Hydraulic fluid, biodegradable, Volvo

Hydraulic fluid, fire-resistant

Hydraulic fluid, for hot climate

External equipment

Cab ladder, rubber-suspended
Deleted front mudguards
Mudguard widener, front/rear for 80-series tires
Mudguard widener, front/rear for 65-series tires
Fire suppression system
Mudguards, full cover, rear for 80-series tires
Mudguards, full cover, rear for 65-series tires
Long boom

Protective equipment

Belly guard front
Belly guard rear
Belly guard rear, oil pan
Cover plate, heavy-duty, front frame
Cab roof heavy duty
Guards for front headlights
Guards for radiator grill
Guards for tail lights
Windows, side and rear guards
Windshield guard
Corrosion protection, painting of machine

Other equipment

CE-marking
Comfort Drive Control (CDC)
Counterweight, re-handling
Counterweight, signal painted, chevrons
Secondary steering with automatic test function
Sound decal, EU
Noise reduction kit, exterior
CareTrack, GSM
CareTrack, GSM/Satellite

Tires

29.5 R25
875/65 R29

Attachments

Buckets:
- Rock straight or spade nose
- General purpose
- Re-handling
- Light material
Wear parts:
- Bolt-on and weld-on bucket teeth
- Segments
- Cutting edge in three sections, bolt-on

VOLVO CONSTRUCTION EQUIPMENT



Volvo Construction Equipment is different. Our machines are designed, built and supported in a different way. That difference comes from an engineering heritage of over 175 years. A heritage of thinking first about the people who actually use the machines. About how to help them be safer, more comfortable, more productive. About the environment we all share. The result of that thinking is a growing range of machines and a global support network dedicated to helping you do more. People around the world are proud to use Volvo. And we're proud of what makes Volvo different.

Not all products are available in all markets. Under our policy of continuous improvement, we reserve the right to change specifications and design without prior notice. The illustrations do not necessarily show the standard version of the machine.

VOLVO

Volvo Construction Equipment
www.volvoce.com

Ref. No 20026149-B
2011.11
Volvo, Global Marketing

English-21
WLO