

STANDARD EQUIPMENT

14504

OPTIONS

14504

GENERAL

- Steel track 500 mm
- Dozer blade
- Working lights on boom and chassis.
- Toolkit incl. grease gun and operator manual

ENGINE

- Deutz watercooled turbo diesel engine
- Automatic RPM speed control
- Diesel fuelling pump
- Electronic air filter soiling indicator

CAB

- Glazed safety cab (ROPS/FOPS/TOPS)
- Cab heating, sliding side window, inward-pivoting windscreen, windscreen wiper/washing system, fully-lined cab interior
- Radio (wiring, speakers, aerial)
- Air conditioning
- Prewiring for cab lights and rotating beacon

HYDRAULICS

- Negative control hydraulic system
- Proportional control for auxiliary hydraulics incl. pressure relief valve
- Enlarged unpressurised return line for various tool attachments
- 3rd control circuit (proportional) incl. pressure relief valve and flat-faced couplers
- Hydraulic damping for drive pedals and throttle
- Overload warning device (safety valve for lifting arm and bucket arm)

CAB

- Automatic air conditioning
- Air-sprung driver's seat
- FOPS protective grille
- Frontguard
- Front and rear working lights
- Dome light

HYDRAULICS

- Panolin Bio-Oil
- BP-Biohyd SE46
- Piping for grab (2 ball valves) incl. flat-faced plug-in coupling
- Hydraulic quick-hitch system preparation
- Powerlift preparation
- Powerlift
- Powerlift with hydraulic quick-hitch system
- Powerlift loading hook with hydraulic quick-hitch system
- Hydraulic quick-hitch system

PAINT

- Special paint 1 RAL for yellow parts only
- Special paint 1 no RAL for yellow parts only
- Special paint Cab RAL (only RAL paint possible)

MISCELLANEOUS

- 500 mm rubber track
- 500 mm rubber track
- 600 mm steel track
- Long bucket arm (+500 mm)
- Central lubrication unit
- CAT engine immobilizer
- Document box

Wacker Neuson compact equipment offers power and manoeuvrability on-the-spot: Any time, any place.

We consider it our constant duty to ensure that our promise regarding our products and services is fulfilled:

Reliability, Trust, Quality, Reactivity, Flexibility and Innovation.

Compact equipment branded Wacker Neuson also does the business where others can only stand and watch. Our products prove their worth through quality, power, intelligent hydraulics, compact dimensions, innovative technology, high productivity and reliability. This gives a form of set-up that only Wacker Neuson – the specialist in compact equipment – is capable of.

You too can take advantage of this bespoke capability. The Wacker Neuson compact class is in a class of its own. With success stamped right through the line.



The Champ

Wacker Neuson Compact Excavator 14504



**WACKER
NEUSON**



**WACKER
NEUSON**



Wacker Neuson factors:

- 14-ton machine with tail-swing console for flexible deployment in the tightest of spaces (2.5 m working width in front of machine).
- Fitted as standard with dozer blade.
- 3 track types (steel, rubber*, and hybrid*).
- Flow rate limitation and adjustability of pump performance.
- Compact dimensions despite weighing in at 14 t.
- Completely new interior of the ROPS/FOPS/TOPS-certified cab.
- Excellent stability thanks to optimal weight distribution.

* Option

The Challenger: The giant in the compact class. Manoeuvrable like no other.



“As manoeuvrable as an 8-tonner, with the efficiency of a 14-tonne excavator and offering the value for money of a true Wacker Neuson ... this was the brief we gave ourselves for developing the 14504, and it's turned out to be a winner on points every time. It is endowed with excellent stability, convincing performance characteristics and a deployment spectrum that no other can match. It rules the roost like a true pro across the entire weight division from 8 through to 14 tonnes. This makes it our all-conquering champion.”

Adolf Pernkopf, 14504 product manager



**Its manoeuvrability makes its strengths count.
Especially when it is backed into a corner.**

The new 14504 offers massively enhanced performance, without the size of the excavator ever posing a problem. It can even carry out the tasks that were previously the province of an 8-tonner with supreme efficiency.

This offers all that extra digging power - and all the reach, digging depth and dump height to go with it - in situations where smaller excavators were previously used.

14504

Wacker Neuson factors:

- High tonnage for compact dimensions.
- Tail-swing console and side-mounted boom cylinder for a low front swing radius.
- Perfect balance of power, manoeuvrability and stability.
- Engine at rear and side-mounted hydraulic control block for unimpeded view to the right.



So versatile: Hydraulics that pack a punch. Ready for anything.

1 The proportional control that comes as standard for the auxiliary hydraulics and 3rd control circuit enables adjustment of the dynamic characteristics in response to the solicitations of the hydraulics and the movements of the respective tool attachments. It is also possible to adjust these characteristics at the flick of a switch, in order to guarantee the best possible synchronisation between excavator and tool.

2 Additional hydraulic control circuit for the use of complex, multifunctional and particularly powerful tool attachments. A real strength of the 14504.

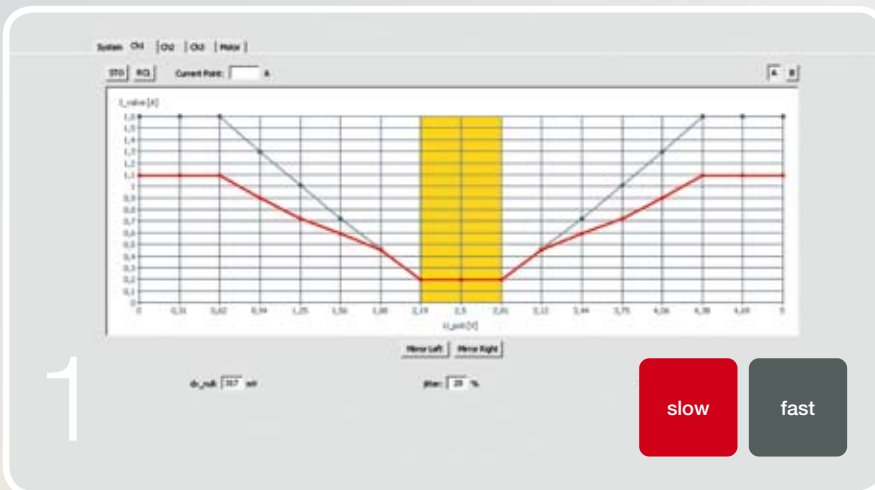

The high-performance hydraulics enable spontaneous actuation of the hydraulic functions and maximum working speed.

What is more, the negative control adjustment means that the hydraulic fluid flow rates are always reduced to match actual need, thereby ensuring an optimum energy balance. The hydraulic performance can be adapted to any given working situation. In addition, the hydraulic fluid flow rate can be reduced by means of a tip switch in order to work more slowly and more precisely.

3 The hydraulic components are situated low and to the side, and offer the driver optimal visibility to the right of his machine. They are very easily accessible.

Automatic RPM speed control. After five seconds without any work movement the engine automatically switches to idle. This reduces fuel consumption and keeps down noise levels.

4 Deutz turbo diesel engine. Low fuel consumption and low noise emissions thanks to optimised engine speed. Its performance is smooth and reliable and it can be easily accessed through its position at the rear of the machine.



Wacker Neuson factors:

- Plug'n Play System: comprehensive hydraulics setup right through to the bucket arm.
- Auxiliary hydraulics with unpressurised return line fitted as standard.
- 3rd control circuit with its own hydraulic pump for hydraulically driven tool attachments (e.g., stone tongs, shears operation).
- Grab piping for attaching a pendular grab*.
- Control circuit for moving the tilt rotators (e.g., Power Tilt or Roto Tilt)*.
- Control circuit for quick-hitch system (e.g., Easy Lock)*.
- The negative control adjustment ensures that the pumps are only supplied with the fluid volumes they actually need.

* Option

2-stage tip switch for individual hydraulics speed adjustment. This flow rate limitation reduces the speed of work movements in the maximum range. There is no reduction to the range of joystick movement.

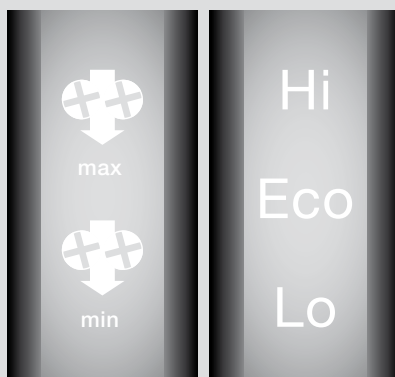

Adjustable pump performance. 3-stage switch with the positions:

- **High** (maximum pump performance for particularly power-intensive work sequences)
- **Eco** (75 % pump performance) for economical operation
- **Low** for slow and sensitive excavator work.



Body awareness: Fresh scope for performance. In prime condition.

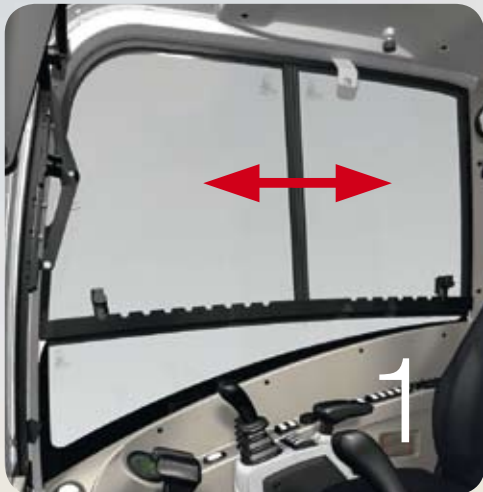

The new cab interior:

- Spacious, additional storage possibilities.
- A complete and well-appointed control panel with large dashboard display and rotary potentiometer showing the engine speed.
- New controls and non-slip drive pedals with servo-control and damping.

The new cab interior: In the service of productivity.

The new 14504 is as smart as it is powerful. In order to exploit its strengths to the max, the driver's working conditions must also match the machine's capabilities.

The cab interior was therefore optimised in consultation with drivers and designers.

1 The side windows can be opened forwards or backwards. This increases air circulation and enhances working comfort.

2 The driver's view to the right is optimised thanks to the low tool height.

3 Always adjusted to personal preferences: The driver's seat can be adjusted to 5 positions for ergonomically-optimised and fatigue-free working conditions.

- Backwards and forwards.
- Backwards and forwards together with the console in order to maintain the distance between driver and instruments.
- Seat height.
- Adjusted to the weight of the driver.
- Adjustable arm and back rests.

A cockpit like it's supposed to be:

- The servo-controlled dozer blade lever is located just alongside the right joystick.
- The newly-designed driver's seat can be adjusted to 5 different positions.
- Comfortable access through a wide door.

Wacker Neuson factors:

- Roomy and entirely redesigned ROPS/FOPS/TOPS-certified cab.
- New, more user-friendly console.
- Excellent side view to the driver's right.
- Air-conditioning as standard.



INNOVATIVE WINDSCREEN SYSTEM

FOR COMFORT, COMMUNICATION AND SECURITY:



1 Fully glazed front part: Excellent visibility and perfect protection from wind and weather. A thoroughly tried-and-tested concept (tilted position).



2 The top sliding part simply slides under the cab roof. There it is safely stowed.



3 Dialogue position: The lower pane is slid under the upper pane. This allows the driver to chat with people outside the excavator.



4 Both sliding panes are stowed under the cab roof. There is no need to remove them or store them elsewhere. This reduces the likelihood of their damage.



The standing colossus: Great groundwork. Powerful musculature.

- 1 The steel track is optimally matched to the crawler and the drive (standard).
- 2 The rubber track expands the deployment possibilities and offers particularly attractive and gentle levelling (option).
- 3 The hybrid track is a jack of all trades, that is a particularly good choice when deployment conditions are subject to rapid change (option).
- 4 The solid rear end made of cast steel provides a first-rate "safety buffer". Proven pro qualities, taking even the toughest deployment conditions in its stride.
- 5 The tail-swing console made from cast steel reduces the front swing radius and enables a working width of approximately 2.5 m in front of the machine.



**Powerful as a heavyweight boxer:
as nimble as a sparring partner.**

The 14504 had to have its day. It offers the answer to the oft-declared desire to combine greater tonnage and considerably more power with the manoeuvrability of a smaller model. And this combination is an uncompromising and thorough success. Its balance of power and stability sets it up on a podium apart from all other compact excavators.

It stands for a new generation.

14504

Wacker Neuson factors:

- Enclosed rear in cast steel.
- Hose guide protection through tail-swing console.
- Solid-cast dozer blade with optimally adjusted radius for even levelling of material.
- Two drive speeds, selectable via tip switch.
- Sloping chassis, less prone to dirt accumulation.
- Non-slip steps.
- 3 track types (each 500 mm width):
Steel track, rubber track*, hybrid track*.

* Option



ca. 2.5 m
working width

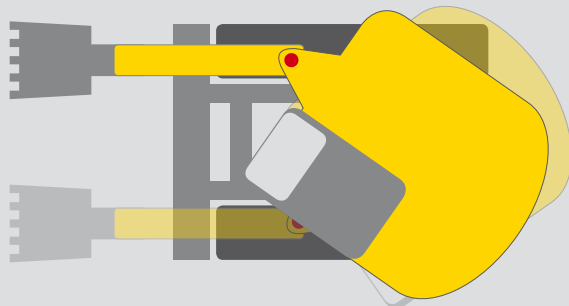

The undisputed champion:
Winning every round.
Top performance every time
it enters the ring.



14504



**THE NEW
HEAVYWEIGHT
IN THE 14T COM-
PACT EXCAVATOR
CLASS.**



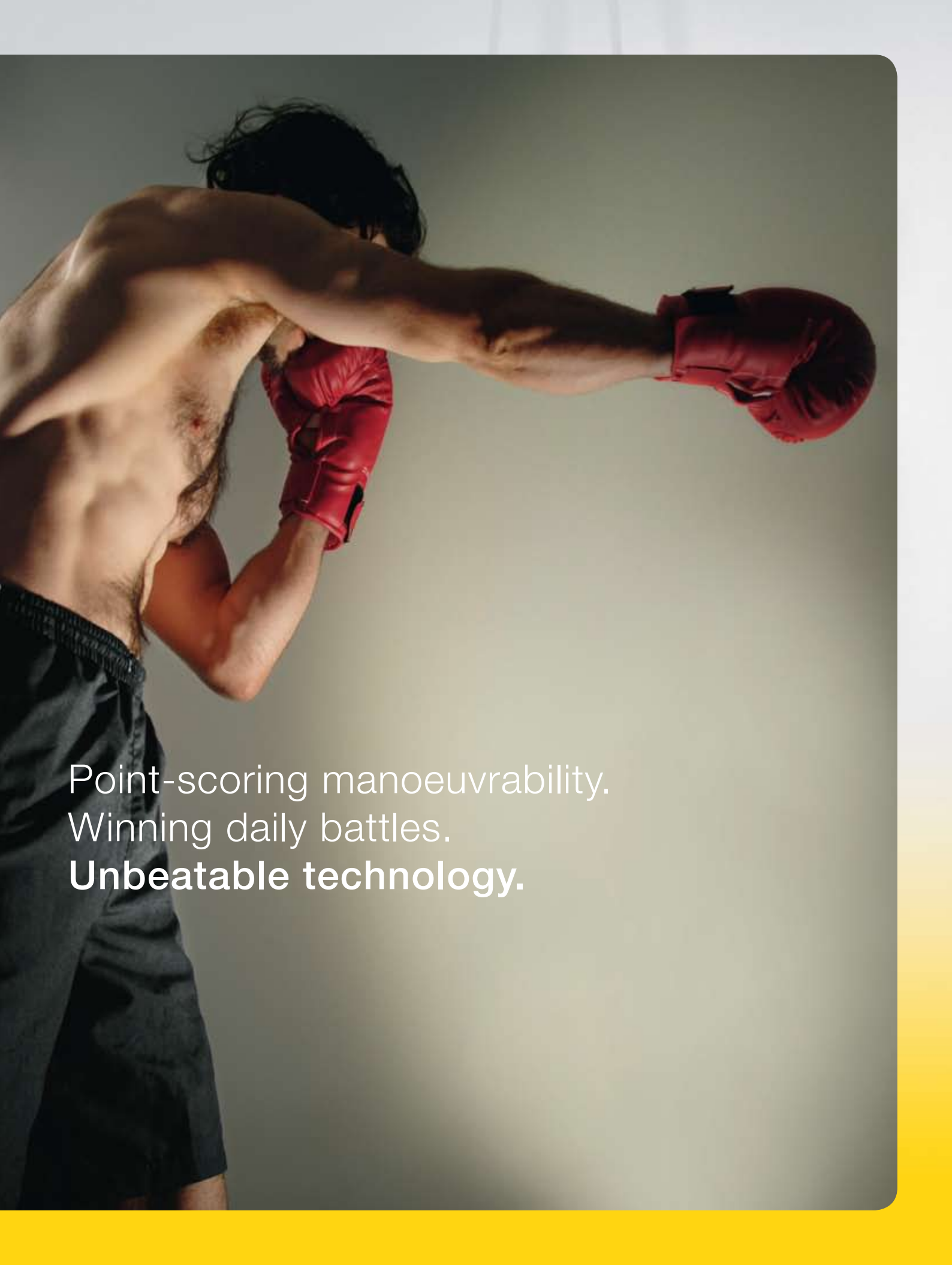

Point-scoring manoeuvrability.
Winning daily battles.
Unbeatable technology.

Big. Strong. Nimble.

Programmed to conquer.

The new 14504 arrives in prime condition. Perfectly coordinated in every movement. It is trained to a tee and ready for anything. It moves with regal poise and climbs into the ring with justifiable self-confidence. It is a genuine Wacker Neuson.

Just watch it win every single round.

When strength enters the fray.
Easy movement in a powerful frame.

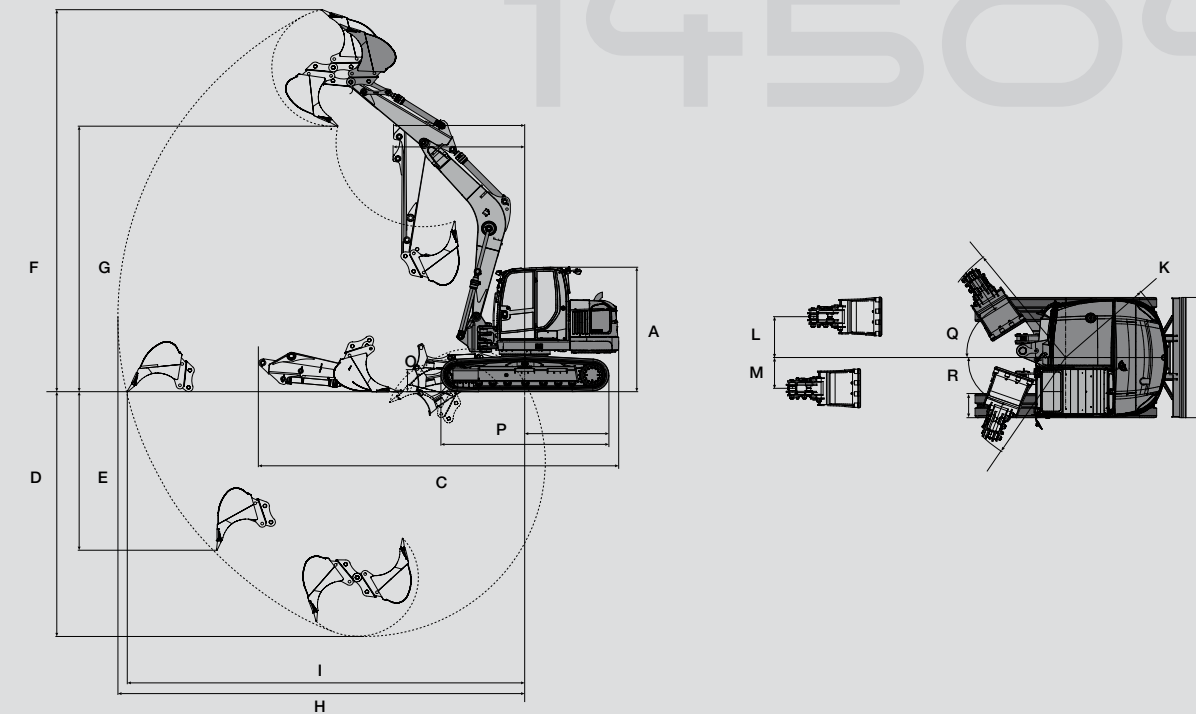

DIMENSIONS

A	Height (Rubber/steel track / hybrid track)	2785 / 2825 mm
B	Transport width	2490 mm
C	Transport length (short / long bucket arm)	7720 / 7790 mm
DIGGER DATA (SHORT / LONG BUCKET ARM)		
	Bucket arm length (short/long)	2070 / 2570 mm
D	Max. digging depth	5000 / 5500 mm
E	Max. vertical digging depth	3100 / 3600 mm
F	Max. digging height	8300 / 8600 mm
G	Max. dumping height	5700 / 6000 mm
H	Max. digging radius	8300 / 8800 mm
I	Max. span on the ground	8100 / 8600 mm
OTHER MEASUREMENTS		
K	Rear pivoting radius	2015 mm
L	Max. boom offset to centre of bucket right side	850 mm
M	Max. boom offset to centre of bucket left side	640 mm
P	Track length	3605 mm
Q	Max. swing angle of boom arm to the right	57°
R	Max. swing angle of boom system to the left	70°

LIFTING POWER

14504 short bucket arm, hybrid steel track

E	A	4 m		5 m		6 m		max.	
		0°	90°	0°	90°	0°	90°	0°	90°
6,0 m	-	-	3234*	3167	-	-	3271*	3094	
4,0 m	3572*	3572*	3349*	3113	3263*	2334	3301*	2055	
2,0 m	6064*	3882	4543*	2852	3828*	2202	3485*	1775	
0,0 m	7333*	3588	5400*	2659	4303*	2087	3758*	1805	
-2,0 m	6629*	3614	4992*	2654	-	-	4094*	2269	
-4,0 m	-	-	-	-	-	-	-	-	

LIFTING POWER

14504 long bucket arm, hybrid steel track

E	A	4 m		5 m		6 m		max.	
		0°	90°	0°	90°	0°	90°	0°	90°
6,0 m	-	-	2569*	2569*	-	-	2879*	2572	
4,0 m	-	-	2866*	2866*	2874*	2365	2966*	1830	
2,0 m	5370*	3977	4142*	2887	3545*	2213	3152*	1601	
0,0 m	7159*	3595	5234*	2651	4182*	2070	3413*	1616	
-2,0 m	6958*	3548	5217*	2597	4029*	2044	3752*	1947	
-4,0 m	-	-	-	-	-	-	4038*	3884	

OPERATIONAL DATA

Transport weight / Operating weight (rubber track)	14450 kg / 15300 kg
Additional weight steel track / hybrid track	265 kg / 170 kg
Max. tear-out force	69.2 kN
Max. tear-out force long bucket arm	60.1 kN
Max. digging force on bucket tooth	91 kN
ENGINE	
Make/Type	Deutz TCD2012-L04
Model	4-cylinder turbo-diesel engine with charge-air cooler
Injection system	Pump circuit nozzle
Engine displacement	4038 cm ³
Performance to ISO	74.9 kW (101.9 hp)
Engine speed	2000 min ⁻¹
Max. RPM without load	2140 rpm
Max. torque	400 Nm at 1600 RPM
Battery	12 V / 120 Ah
Diesel tank capacity	205 l
HYDRAULIC SYSTEM	
Pump	2 x variable pumps, 2 x gear pumps
Pump settings performance Hi / ECO / Lo	60 / 52 / 45 kW
Variable pump flow rate	2 x 126 l/min
Gear pump 1/2 flow rate	1 x 21.5 l/min / 1 x 32.0 l/min
Operating pressure for work and drive hydraulics	340 bar
Operating pressure for slewing gear	320 bar
System capacity hydraulic fluid	235 l
Hydraulic tank capacity	110 l
RUNNING GEAR AND SLEWING GEAR	
Driving speeds 1st gear / 2nd gear	3.0 km/h / 5.1 kph
Max. theoretical traction force 1st gear	10.7 t
Gradeability	35°
Track width	500 mm
No. of track rollers per side	7
Ground clearance	480 mm
Ground pressure	0.49 kg/cm ²
Crawler width	2490 mm
Crawler length (total / sprocket wheel)	3605 / 2890 mm
Superstructure slewing speed	11.6 min ⁻¹
DOZER BLADE	
Width / Height	2490 x 600 mm
Max. lift height of dozer blade above ground	535 mm
Max. lift height of dozer blade below ground	495 mm
NOISE EMISSIONS	
Noise level (L) as per 2000/14/EC	98 dB(A)

A Projection from turnstile centre

E Load fixing height from ground level

* Lifting power is hydraulically restricted. All table values are given in kg, in a horizontal position on a solid surface and without bucket. If a bucket or other device is attached, the lifting power or lifting load is reduced by its own tare weight.
Basis of calculation: in acc. with ISO 10567. The lifting power of the compact excavator is limited by the settings of the pressure relief valve and the tilt safety mechanism. Neither 75% of the static lifting load nor 87% of the hydraulic lifting power are exceeded.

0°		with dozer blade support in the direction of travel
90°		without dozer blade support 90° to direction of travel