



# Bobcat®

## T2250

Telescopic Handlers



# T2250: the three-in-one special!

## ■ Not your average machine

With the T2250, you get the capabilities and productivity of a Bobcat telescopic handler, skid-steer and articulated loader – from one exceptionally versatile machine!



## Loading tradition in a compact package

Only 1.95 m high and 1.83 m wide, the T2250 is as compact and manoeuvrable as our skid-steer loaders, with the capacity of a larger machine.

## Versatility

Thanks to our Bob-Tach™ system, the T2250 is compatible with most Bobcat loader attachments.



## Agile as an articulated loader

The 3 steering modes – front wheel, 4-wheel or crab-steer – let you go anywhere.

With the optional boom float, the boom and attachment can smoothly follow uneven surfaces. And the panoramic view from the cab offers 360° visibility, for greater safety and speed.



## All the reach of a telescopic handler

- Lift and load: with the T2250, you can lift 2.2 tons up to 5.2 m high.
- How far do you want to go? With a 1 ton load, the T2250 offers a maximum reach of 3 metres.

# Compact telescopic loader

## ■ Born to load

Not a compromise, but a combination. This machine is equipped to tackle all your loading jobs...but with greater reach and lifting height than any loader.



## ■ Making fast work of tough jobs

The T2250's optimised 'Z' bar kinematics increases bucket dumping and crowding angles, and improves the bucket thrust when loading. Your overall operation is quicker and the breakout force is optimised.

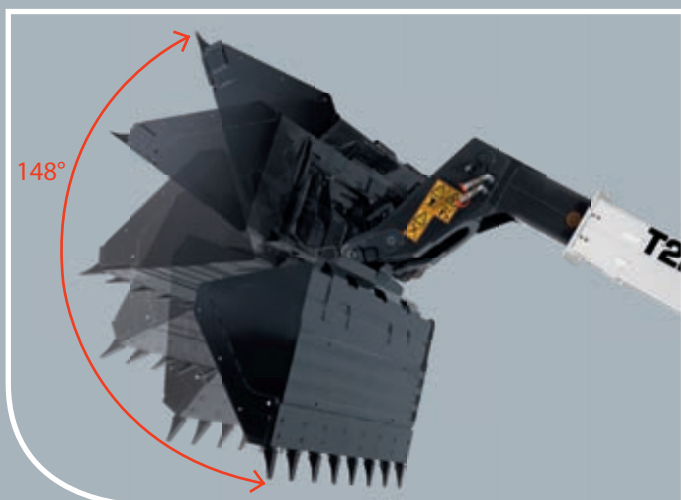

## Simultaneous two foot drive

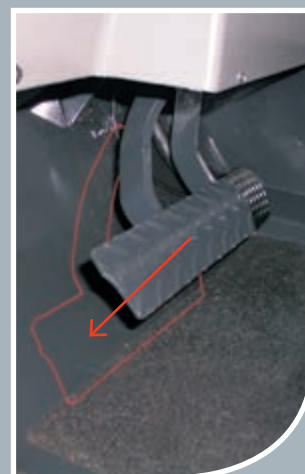

Keep 100% control when loading with one foot on the throttle and one foot on the inching pedal. The inching pedal slows forward movement without changing engine speed.

## Standard, fully proportional joystick

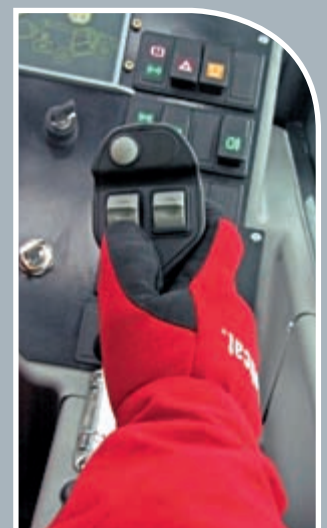

All movements are proportional and can be combined, thanks to our load sensing system.

# Combining comfort and efficiency

## ■ 360° visibility

### For better productivity and safety

With the engine located on the side of the machine, the T2250 offers 360° visibility from the cab. This design also ensures easier access for routine maintenance.



## ■ All the features you need

- Reinforced undercarriage for greater robustness
- Attachment Control Device (ACD) for joystick control of certain attachments
- Creep mode is standard!

It enables low travel speed at high engine rpm, so you always have sufficient hydraulic flow to operate attachments such as sweepers or feeding buckets.

## ■ Easy service and greasing

- Ready access to all key components
- No special tools required.



The operator can drive the machine in creep mode while maintaining full engine speed.



# Versatile as a Bobcat loader

## Flexibility

Our quick-attach systems let you switch attachments at a moment's notice.

Our manual solutions:

- Bob-Tach™
- Quick-Tach

Optional – change attachments without even leaving your cab:

- Hydraulic Quick-Tach.

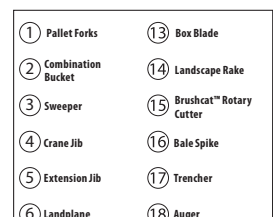
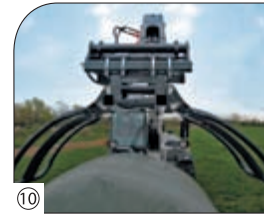
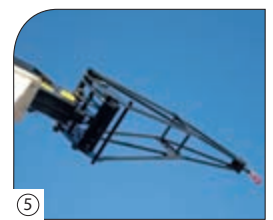
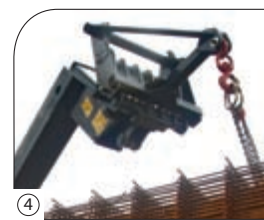
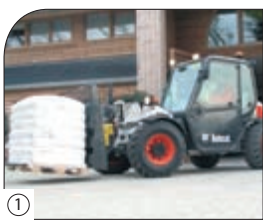

- |                        |                           |
|------------------------|---------------------------|
| ① Pallet Forks         | ⑬ Box Blade               |
| ② Combination Bucket   | ⑭ Landscape Rake          |
| ③ Sweeper              | ⑮ Brushcat™ Rotary Cutter |
| ④ Crane Jib            | ⑯ Bale Spike              |
| ⑤ Extension Jib        | ⑰ Trencher                |
| ⑥ Landplane            | ⑱ Auger                   |
| ⑦ Angle Broom          | ⑲ Vibratory Roller        |
| ⑧ Fork with Grapple    | ⑳ Dozer Blade             |
| ⑨ Tiller               | ㉑ Snow Blade              |
| ⑩ Bale Squeeze Handler | ㉒ Snow V-Blade            |
| ⑪ Bucket with Grapple  | ㉓ Scraper                 |
| ⑫ Mower                | ㉔ Snowblower              |

## Performance

Lifting height (Bob-Tach™)	5230 mm
Lifting height (Quick-Tach)	5210 mm
Rated capacity	2200 kg
Capacity at max. height	2200 kg
Capacity at max. reach (Bob-Tach™)	1000 kg
Capacity at max. reach (Quick-Tach)	950 kg
Max. reach (Bob-Tach™)	3010 mm
Max. reach (Quick-Tach)	3030 mm
Crowding force	2100 daN

## Weights

Weight (unladen)	4695 kg
------------------	---------

## Traction

Standard tyres	14x17.5
Low speed (forward / reverse)	0-7 km/h
High speed (forward / reverse)	0-25 km/h
Driving modes	Direct drive / soft drive

## Drive System

Transmission	Hydrostatic with electronic regulation
Main drive	2-speed hydrostatic motor

## Engine

Make / Model	KUBOTA / V3800-DI Turbo
Fuel / Cooling	Diesel / Water-cooled
Rated power (DIN 6271) at 2400 RPM	55.9 kW (75 HP)
Maximum torque at 1600 RPM	274 Nm
Number of cylinders	4
Displacement	3.8 l

## Hydraulic System

Pump type	Gear pump with LS valve
Combined pump capacity	85 l/min
Working pressure	240 bar

## Cycle Times

Lift time - no load	4.7 s
Lower time - no load	6.5 s
Telescope in time at max. reach - no load	4.2 s
Telescope in time at max. height - no load	4.2 s
Telescope out time at max. reach - no load	5.7 s
Telescope out time at max. height - no load	5.8 s

## Brakes

Engine braking	Hydrostatic
Parking and emergency brake	Negative brake with hydraulic command

## Fluid Capacities

Axles and reduction gears front / rear	8.9 / 5.6 l
Engine oil	12 l
Fuel tank	91 l
Hydraulic reservoir (hydraulic / overall)	29 / 44 l

## Standard Features

Aggravating Movements Arrester (AMA)	Quick-Tach
Hydrostatic transmission	Front and rear work lights on cab
ROPS/FOPS operator cab	Creep function (or SMS: Speed Management System)
Heating, demisting and ventilation	
Front and rear washer/wipers	
Seat with self retracting seat belt	

## Options

Back-up alarm	Protective grill for windscreen
Air conditioning	Transmission lock override
Rotating beacon	Float function
Rear hydraulic auxiliary	Bob-Tach™
Boom light	Hydraulic line at boom end with ACD
Set of blue lights for hen houses	Hydraulic line at boom end with ACD
Carriage with hydraulic attachment lock	Boom stop
Roof window wiper	

## Load Charts

With forks and 14 x 17.5 tyres, with Bob-Tach™

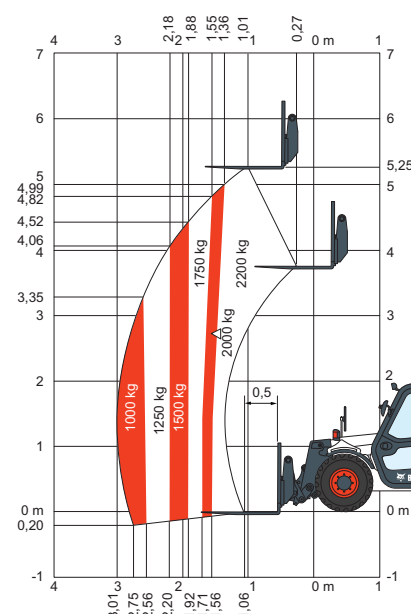

Complies with stability test EN1459 Annex B.

## Dimensions

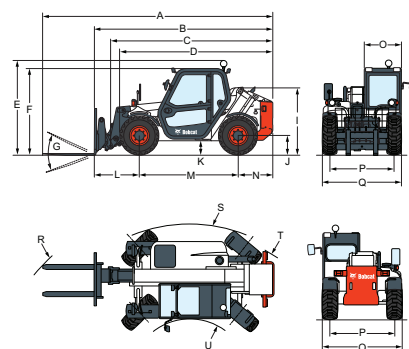

(A)	5330 mm	(G)	148°	(M)	2300 mm
(B)	4145 mm	(I)	1553 mm	(O)	860 mm
(C)	3984 mm	(J)	430 mm	(P)	1485 mm
(D)	4000 mm	(K)	294 mm	(Q)	1840 mm
(E)	3585 mm			(R)	4280 mm
(F)	2185 mm			(S)	3170 mm
	1985 mm			(T)	— mm
				(U)	1500 mm

Specifications and design are subject to change without notice. Pictures of Bobcat products may show other than standard equipment.

www.bobcat.eu



# Bobcat®

