



Bobcat®

T40170

Telescopic Handlers



Performance

Lifting height — on stabilisers	17430 mm
Lifting height — on tyres	17180 mm
Rated capacity	4000 kg
Capacity (at max. height — on stabilisers)	2500 kg
Capacity (at max. reach — on stabilisers)	560 kg
Capacity (at max. height — on tyres)	1250 kg
Capacity (at max. reach — on tyres)	0 kg
Max. reach — on stabilisers	13670 mm
Max. reach — on tyres	13730 mm
Crowding force	5000 daN

Weights

Weight (unladen)	10970 kg
------------------	----------

Traction

Standard tyres	BF GOODRICH 400/80x24
Low speed (forward/reverse)	0–8 km/h
High speed (forward/reverse)	0–30 km/h
Driving modes	Direct drive / soft drive

Drive System

Transmission	Hydrostatic with electronic regulation
Main drive	2-speed hydrostatic motor

Engine

Make / Model	PERKINS / 1104D-44TA Turbo
Fuel / Cooling	Diesel / Water
Rated power (DIN 6271) at 2200 RPM	74.5 kW (100 HP)
Maximum torque at 1400 RPM	410 Nm
Number of cylinders	4
Displacement	4.4 l

Hydraulic System

Pump type	Gear pump with LS valve
Combined pump capacity	135 l/min
Working pressure	250 bar

Cycle Times

Lift time — no load	12.6 s
Lower time — no load	6.4 s
Telescope in time at max. reach — no load	19.4 s
Telescope in time at max. height — no load	16.6 s
Telescope out time at max. reach — no load	28.9 s
Telescope out time at max. height — no load	29.0 s

Brakes

Engine braking	Hydrostatic
Parking and emergency brake	Negative brake with hydraulic command

Fluid Capacities

Axles and reduction gears front / rear	11.9 / 11.4 l
Engine oil	8.5 l
Fuel tank	140 l
Hydraulic reservoir	77 l

Standard Features

- Aggravating Movements Arrester (AMA)
- Hydrostatic transmission
- ROPS/FOPS operator cab
- Heating, demisting and ventilation
- Front and rear washer/wipers
- Suspension seat
- Two-way hydraulic supply at the end of the boom
- Narrow hook-up for mounting of the equipment
- Mechanical lock of the equipment

Options

- Back-up alarm
- Man platform predisposition
- 2nd hydraulic function on boom
- Cab air conditioning
- Rotating beacon
- Cooling fan reverser for cleaning purposes
- Work light on boom
- Hydraulic lock of equipment
- Yoke + electrical plug
- Roof windscreen wiper
- Windscreen grill
- Radio remote control
- Transmission lock override
- DUNLOP 400/80x24 153B T37 TL tyres

Load Charts

With forks and standard BF GOODRICH 400/80x24, DUNLOP 400/80x24 tyres — on stabilisers

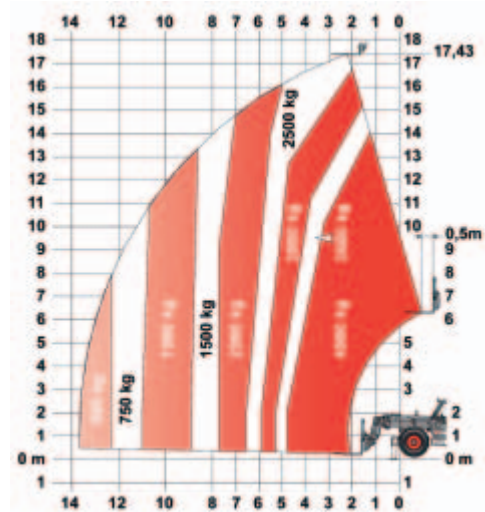

Dimensions

All dimensions in mm.

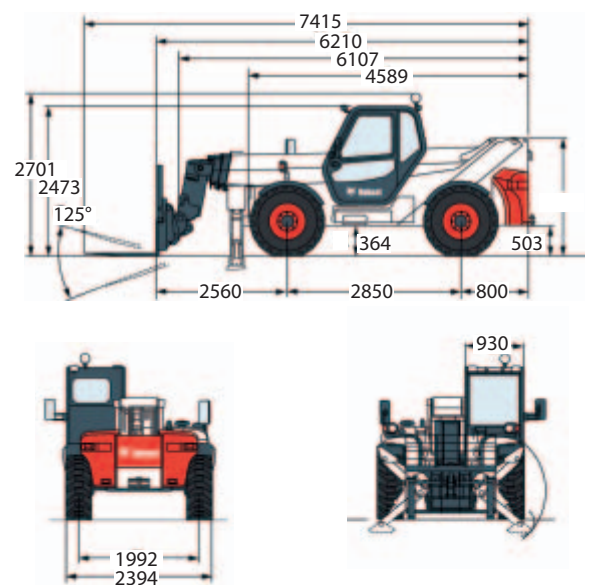

www.bobcat.eu



Bobcat®

Specifications and design are subject to change without notice - Pictures of Bobcat units may show other than standard equipment.