



TL470 | Telescopic Handlers



Performance

Lifting height	6957 mm
Rated capacity	3500 kg
Capacity (at max. height)	3000 kg
Capacity (at max. reach)	1500 kg
Max. reach	4002 mm
Crowding force	6200 daN

Weights

Weight (unladen)	7130 kg
------------------	---------

Traction

Standard tyres	400/70x20 150B
1st gear / low range (40 km/h option)	6 (6) km/h
1st gear / high range (40 km/h option)	11 (12) km/h
2nd gear / low range (40 km/h option)	16 (18) km/h
2nd gear / high range (40 km/h option)	30 (40) km/h

Drive System

Transmission	Hydrostatic with electronic regulation
Main drive	Hydrostatic motor with 2 speed gearbox

Engine

Make / Model	PERKINS / 1104D-44TA
Fuel / Cooling	Diesel / Liquid
Rated power (DIN 6271) at 2200 RPM	74.5 kW (100 HP)
Maximum torque at 1400 RPM	410 Nm
Number of cylinders	4
Displacement	4.4 L

Hydraulic System

Pump type	Gear pump with LS valve
Combined pump capacity	100 L/min
Working pressure	255 bar

Cycle Time

Lift time - no load	8 s
Lower time - no load	6.0 s
Telescope in time at max. reach - no load	6.7 s
Telescope in time at max. height - no load	6.7 s
Telescope out time at max. reach - no load	7.1 s
Telescope out time at max. height - no load	7.1 s

Brakes

Engine braking	Hydrostatic
Parking and emergency brake	Negative brake with hydraulic command

Fluid Capacities

Axes and reduction gears front / rear	9.1 / 9.1 L
Engine oil	8.5 L
Fuel tank	138 L
Hydraulic reservoir	59 L

Standard Features

Aggravating Movements Arrester (AMA)	Suspension seat
Hydrostatic transmission	Two way hydraulic supply at the end of the boom
ROPS/FOPS operator cab	Narrow hook-up for mounting of the equipment
Heating, demisting and ventilation	Mechanical lock of the equipment
Front and rear washer/wipers	

Options

Air conditioning	Load sensing pump
Auxiliary line on boom with ACD and electric connectors	Lockable fuel cap
Back-up alarm	Manitou carriage with hydraulic attachment lock
Basic tow hitch	Manually adjustable drawbar coupler tow hitch
Blue lights for henhouses	No forward/reverse control on joystick
Boom float	Pintle tow hitch
Boom light	Proportional engine fan with inverter
Boom stop	Protective grill for windshield
Boom suspension	Quicktach carriage with hydraulic attachment lock
Catalytic purifier muffler	Rear auxiliary line
Cold start	Rear auxiliary line with hydraulically adjustable tow hook
Custom colour	Rear electric auxiliary
Cyclonic air prefilter	Safety hammer
Double right rear view mirror	Sears air suspension seat
Drawbar coupler tow hitch	Support for vehicle registration plate with rear hydraulic hitch
Fire extinguisher	Support for vehicle registration plate without rear hydraulic hitch
Front tow hitch	Tool box
Grammer air suspension seat	Transmission 40 km/h
Hydraulically adjustable tow hook	Wheel wedge

Load Charts

With forks and DUNLOP 400/80-24 150B T37 tyres

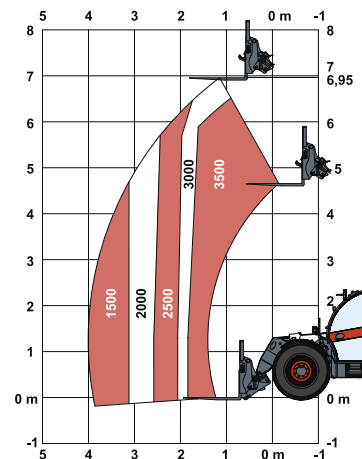

Complies with stability test EN1459 Annex B.

Dimensions

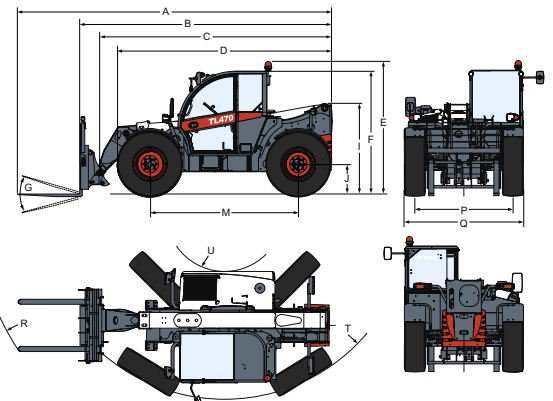

(A)	6074 mm	(G)	135°	(M)	2870 mm
(B)	4869 mm	(I)	1752 mm	(N)	643 mm
(C)	4763 mm	(J)	430 mm	(O)	1013 mm
(D)	4145 mm	(K)	— mm	(P)	1895 mm
(E)	2561 mm	(L)	1356 mm	(Q)	2300 mm
(F)	2374 mm			(R)	5015 mm
				(S)	3714 mm
				(T)	— mm
				(U)	1092 mm



www.bobcat.eu