



Bobcat[®]

TR45190

Telescopic Handlers



Performance

Lifting height — on stabilisers	18700 mm
Lifting height — on tyres	18400 mm
Rated capacity	4500 kg
Capacity (at max. height — on stabilisers)	3000 kg
Capacity (at max. height — on tyres)	1200 kg
Capacity (at max. reach — on stabilisers)	500 kg
Capacity (at max. reach — on tyres)	400 kg
Max. reach — on stabilisers	16400 mm
Max. reach — on tyres	12200 mm

Weights

Weight (unladen)	16400 kg
------------------	----------

Traction

Standard tyres	18 — R22.5in
Low speed (forward/reverse)	10 km/h
High speed (forward/reverse)	40 km/h

Drive System

Transmission	Hydrostatic with hydraulic regulation
Main drive	2-speed gear box

Engine

Make/Model	PERKINS / 1104D-ETA
Fuel / Cooling	Diesel / Liquid
Rated power (DIN 6271) at 2200 RPM	106 kW (144 HP)
Maximum torque at 1400 RPM	556 Nm
Number of cylinders	4
Displacement	4.4 l

Hydraulic System

Pump type	Double gear pump
Working pressure	230 bar

Function Time

Lift time — no load	18.0 s
Lower time — no load	13.0 s
Telescope in time at max. reach — no load	21.0 s
Telescope in time at max. height — no load	16.0 s
Telescope out time at max. reach — no load	28.0 s
Telescope out time at max. height — no load	27.0 s

Brakes

Engine braking	Hydrostatic
Parking brake	Negative brake with electro-hydraulic command on rear axle

Fluid Capacities

Axles and reduction gears front/rear	10 / 10 l
Engine oil	9 l
Fuel tank	180 l
Hydraulic reservoir	270 l

Standard Features

Man platform ready	Front and rear washer/wipers
Hydrostatic transmission	Suspension seat
Two way hydraulic supply at the end of the boom	Road lights
Back-up alarm	
Boom stop	
Lockable fuel cap	
Heating, demisting and ventilation	
Carrige with manual attachment lock	
ROPS/FOPS operator cab	

Options

Special painting	Electric contact on boom head
Pneumatic seat (compulsory with double joystick)	Sun visor
Carrige with hydraulic attachment lock	Wheel alignment indicator
Controls with double joystick	Cold weather kit
TÜV homologation	Cold start (engine water heater)
Remote control	Webasto heater (Cold weather kit is compulsory)
Second auxiliary hydraulic line with electrical line	Digital speedometer and odometer
Work light on top of cabin	Pallet fork transversal block
Air conditioning	Anti-theft immobiliser
Boom light	Catalytic exhaust purifier
Radio	Centering handler and positive/negative jib pre-arrangement
Radio with CD player	Spare wheel 22.5in
Protective grill for windshield	Stabilizer security 30 degrees
Limited slip differential for rear axle	Stabilizers and leveling security 30 degrees

Load Charts

On stabs, with forks, 90 degrees

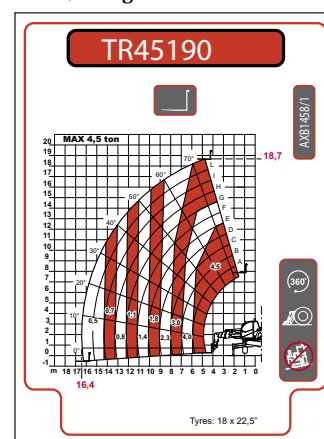

Dimensions

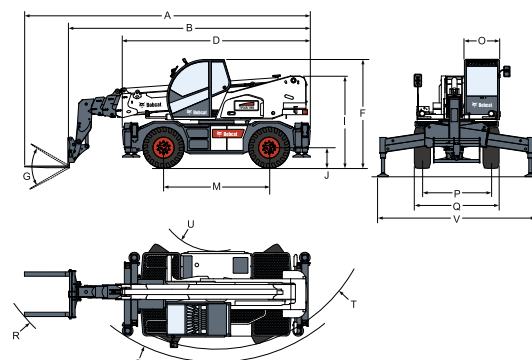

(A)	7910 mm	(G)	134°	(M)	2950 mm
(B)	6760 mm	(I)	2580 mm	(O)	980 mm
(D)	5250 mm	(J)	320 mm	(P)	1920 mm
(F)	3020 mm			(Q)	2380 mm
				(R)	6410 mm
				(S)	4790 mm
				(T)	4430 mm
				(U)	1700 mm



www.bobcat.eu