



# Bobcat®

## TR50210

### Telescopic Handlers



## Performance

Lifting height — on stabilisers	20500 mm
Lifting height — on tyres	20300 mm
Rated capacity	5000 kg
Capacity (at max. height — on stabilisers)	2500 kg
Capacity (at max. height — on tyres)	1200 kg
Capacity (at max. reach — on stabilisers)	400 kg
Capacity (at max. reach — on tyres)	400 kg
Max. reach — on stabilisers	18100 mm
Max. reach — on tyres	12700 mm

## Weights

Weight (unladen)	17200 kg
------------------	----------

## Traction

Standard tyres	18 — R22.5in
Low speed (forward/reverse)	10 km/h
High speed (forward/reverse)	40 km/h

## Drive System

Transmission	Hydrostatic with hydraulic regulation
Main drive	2-speed gear box

## Engine

Make/Model	PERKINS / 1104D-ETA
Fuel / Cooling	Diesel / Liquid
Rated power (DIN 6271) at 2200 RPM	106 kW (144 HP)
Maximum torque at 1400 RPM	556 Nm
Number of cylinders	4
Displacement	4.4 l

## Hydraulic System

Pump type	Double gear pump
Working pressure	230 bar

## Function Time

Lift time — no load	18.0 s
Lower time — no load	13.0 s
Telescope in time at max. reach — no load	21.0 s
Telescope in time at max. height — no load	16.0 s
Telescope out time at max. reach — no load	28.0 s
Telescope out time at max. height — no load	27.0 s

## Brakes

Engine braking	Hydrostatic
Parking brake	Negative brake with electro-hydraulic command on rear axle

## Fluid Capacities

Axles and reduction gears front/rear	10 / 10 l
Engine oil	9 l
Fuel tank	180 l
Hydraulic reservoir	270 l

## Standard Features

Man platform ready	ROPS/FOPS operator cab
Hydrostatic transmission	Front and rear washer/wipers
Two way hydraulic supply at the end of the boom	Suspension seat
Back-up alarm	Road lights
Boom stop	
Lockable fuel cap	
Rotating beacon	
Heating, demisting and ventilation	
Carnage with manual attachment lock	

## Options

Special painting	Electric contact on boom head
Pneumatic seat (compulsory with double joystick)	Sun visor
Carnage with hydraulic attachment lock	Wheel alignment indicator
Controls with double joystick	Cold weather kit
TÜV homologation	Cold start (engine water heater)
Remote control	Webasto heater (Cold weather kit is compulsory)
Second auxiliary hydraulic line with electrical line	Digital speedometer and odometer
Work light on top of cabin	Pallet fork transversal block
Air conditioning	Anti-theft immobiliser
Boom light	Catalytic exhaust purifier
Radio	Centering handler and positive/negative jib pre-arrangement
Radio with CD player	Spare wheel 22.5in
Protective grill for windshield	Stabilizer security 30 degrees
Limited slip differential for rear axle	Stabilizers and leveling security 30 degrees

## Load Charts

On stabs, with forks, 90 degrees

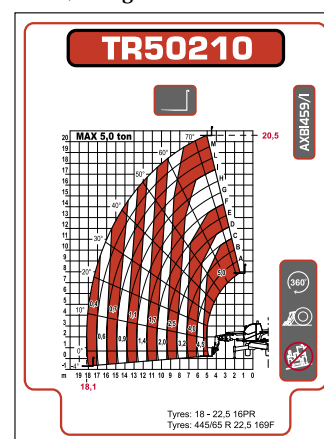

## Dimensions

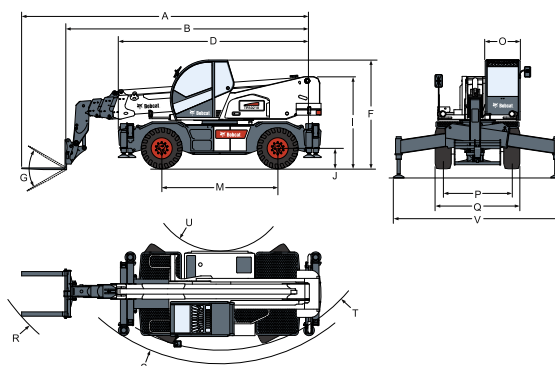

(A)	8360 mm	(G)	134°	(M)	3250 mm
(B)	7150 mm	(I)	2580 mm	(O)	980 mm
(D)	5680 mm	(J)	320 mm	(P)	1920 mm
(F)	3030 mm			(Q)	2380 mm
				(R)	6720 mm
				(S)	5130 mm
				(T)	4750 mm
				(U)	1980 mm



www.bobcat.eu