



Bobcat®

T110

Compact Tracked Loaders



A mighty miniature

The industry's most compact tracked loader, the Bobcat T110, offers you an agile workhorse for all kinds of landscaping and construction jobs.

And you can use this mighty miniature just about anywhere – drive it through narrow openings, between obstructions and into small spaces.



Do more jobs more quickly, 365 days a year

■ The best power-to-weight ratio of any loader

You get excellent productivity from this little machine with a big heart. Its impressive lifting capacity and pushing force belie the loader's size, while the multi-function hydraulic system gives it the fastest cycle times in its class. The undercarriage system provides excellent traction, allowing you to work in any ground conditions and in any weather.

Need to work on slopes? No problem: the T110's stability allows it to operate on serious inclines of up to 35% or 20°.

Tough on performance, light on its feet

Perfect for all your gardening tasks, the T110 goes easy on green areas – it virtually skips over turf and sod!



When is a loader not just a loader?

■ When it's a versatile Bobcat loader fitted with one of the many dozens of handy attachments

With pallet forks, buckets and forks with grapples, as well as soil conditioners, tillers and trenchers, you can do almost anything with the T110: from digging and breaking to land planing, sweeping and scraping.

And it's so easy for operators to change attachments, via the Bob-Tach™ mounting system. Add the optional Power Bob-Tach™ and many can even be changed without the operator leaving the cab.

Simply imagine the possibilities

Can you imagine all the applications the T110 compact tracked loader can handle? Whether in landscaping, gardening, ground preparation or construction, the possibilities are endless.



Take me with you!

Taking compact loaders to a new dimension, the T110 offers you the ultimate in transportability. You don't even need a truck to carry it. At under 2.4 tons in weight and 1.2 metres in width, it fits snugly onto a trailer, ready for you to tow it to your next location.



■ In a comfort class of its own

This little machine is big on operator comfort and usability! You'll be amazed at just how much space you have in the cab. And with the high-visibility front door – a standard feature! – and the side windows you can slide right open, you get even more comfort and safety.

■ Easy maintenance, less downtime

Minimizing downtime gives you the edge when it comes to productivity. Routine maintenance makes a big difference, so we make sure you can get to the key hydraulic and hydrostatic components easily and quickly.



Transverse-mounted engine and swing open tailgate offer increased ease of maintenance.

Machine Rating

Rated operating capacity, Bobcat	499 kg
Rated operating capacity, ISO 14397-1	505 kg
Tipping load	1443 kg
Pump capacity @ 91% efficiency	47.5 l/min
System relief at quick couplers	20.7 MPa
Travel speed	8.4 km/h

Engine

Make / Model	Kubota / V2403-M-DI-E3
Fuel / Cooling	Diesel / Liquid
Power	31.2 kW
Torque at 1400 RPM (SAE J1 995 Gross)	155.9 Nm
Number of cylinders	4
Displacement	2434 cm ³
Fuel tank capacity	45.2 l

Weights

Operating weight	2379 kg
------------------	---------

Controls

Vehicle steering	Direction and speed controlled by two hand levers
Loader hydraulics tilt and lift	Two foot pedals.
Front auxiliary (standard)	Lateral movement of the right-hand steering lever

Drive System

Transmission	Infinitely variable tandem hydrostatic piston pumps, driving two fully reversing hydrostatic motors
--------------	---

Standard Features

High-back cushion suspension seat	Instrumentation
Automatically activated glow-plugs	Lift arm support
Bob-Tach™ frame	Operating lights, front and rear
Bobcat Interlock Control System (BICS)	Parking brake
Deluxe operator cab	Seat belt
Includes interior cab foam, side, top and rear windows	Seat bar
Front door w/ windshield wiper	Spark arrestor muffler
Engine/hydraulics system shutdown	CE certification
Hydraulic bucket positioning	

* Roll Over Protective Structure (ROPS) – meets requirements of SAE-J1040 and ISO 3471; Falling Object Protective Structure (FOPS) - meets requirements of SAE-J1043 and ISO 3449, Level I

Options

Power Bob-Tach™	Deluxe instrument panel
Cab enclosure with heating	

Dimensions

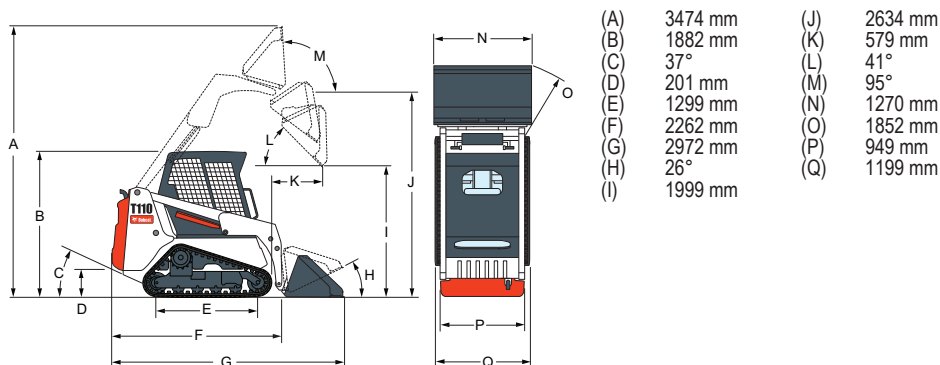

Attachments

Angle blade / Snow blade
Angle broom*†
Auger
Backhoe
Buckets (C/I & L/P)
Digger
Dumping hopper
Mower
Grapples and forks
Hydraulic breaker**
Landplane
Pallet forks
Scarifier
Snow blower*
Snow V-blade
Soil conditioner
Scraper
Sweeper
Three-point hitch
Tiller
Trencher

*Attachment control kit required.
 **When operating the loader with this attachment, a Special Applications Kit, which includes a 12 mm Lexan front door with 6 mm top and rear windows, must be used.
 †Optional water kit.

Specifications and design are subject to change without notice. Pictures of Bobcat products may show other than standard equipment.

www.bobcat.eu



Bobcat®

