



Bobcat®

S100

Compact Loaders



Changing the balance of power

Big power, big benefits

Compact as it is, the S100 loader is powerful too, with high lift- and tilt breakout forces. The superior engine horsepower, the advanced control valve and the efficient hydraulic pumps deliver outstanding hydraulic flow. So your operational efficiency goes up, and your costs go down!



Need to squeeze in buildings?

The S100 is so compact it can fit wherever you need it to go: through backyard gates for landscaping, inside for interior demolition, and much more. And with its performance and durability, the S100 will redefine your expectations from a compact loader.

Don't compromise: optimize!

What's your job today? Tilling, trenching, sweeping, scraping, breaking, dumping... the S100 is always your best partner!



You deserve it all

Comfort you can count on

You'll be amazed by the spacious feeling of the cab, with its ergonomic controls, operator suspension seat and the excellent visibility of the attachment.

The custom-designed headlights allow you to work efficiently even when it's dark. If you opt for the Power Bob-Tach, you can change attachments much more easily without leaving the cab.

Technology you can rely on

The instrument panel is packed with state-of-the-art technology. Stay informed at all times, with instant diagnostics and a full complement of gauges, indicators and controls. But we've kept it simple to use, so it makes your work easier.



Safety you can trust

The S100 offers several safety features, for the operator and the crew. The domed roof of the cab is reinforced with additional ribs. Sound dampening and reduced vibration lessen operator fatigue. The seat bar provides optimum protection.



Move it!

With its low weight – only 1800 kg – you can easily transport the S100 from worksite to worksite. It goes where you need it – when you need it!



Up and running – fast!

With everything the S100 can do, you'll want to keep it up and running. Service is a breeze, with easy access provided by the transverse-mounted engine and large tailgate. Plus, with no chain adjustments or drive belt tensioning needed, downtime – and cost of ownership – is decreased even more.



Machine Rating

Rated operating capacity	457 kg
Tipping load	915 kg
Pump capacity	50 l/min
System relief at quick couplers	207 bar
Max. travel speed	10.4 km/h

Engine

Make / Model	Kubota / V1505-E2B-BCZ
Fuel / Cooling	Diesel / Liquid
Maximum power at 3000 RPM (SAE J1349)	25 kW
Torque at 1700 RPM (SAE J1349)	93 Nm
Number of cylinders	4
Displacement	1498 cm ³
Fuel tank capacity	45 l

Weights

Operating weight (with std tyres, 48 inch bucket)	1800 kg
Operating weight (with hd tyres, 50 inch bucket)	1818 kg

Controls

Vehicle steering	Direction and speed controlled by two hand levers
Loader hydraulics tilt and lift	Separate foot pedals
Front auxiliary (standard)	Lateral movement of right-hand steering lever

Drive System

Transmission	Infinitely variable tandem hydrostatic piston pumps, driving two fully reversing hydrostatic motors
--------------	---

Standard Features

Automatically activated glow plugs	Parking brake
High-back cushion suspension seat	Seat belt
Bob-Tach™ frame	Seat bar
Engine / Hydraulic system shutdown	Spark arrestor muffler
Bobcat Interlock Control System (BICS)	27 x 8.50-15, 6-ply, Bobcat heavy duty tyres
Operating lights, front and rear	CE certification

Instrumentation

Lift arm support

Deluxe operator cab* Includes interior cab foam, side, top and rear windows

* Roll Over Protective Structure (ROPS) - meets requirements of SAE-J1040 and ISO 3471; Falling Object Protective Structure (FOPS) - meets requirements of SAE-J1043 and ISO 3449, Level I

Options

Heated enclosed cab	Hydraulic bucket positioning (including ON/OFF switch)
Power Bob-Tach™	Counterweights

Dimensions

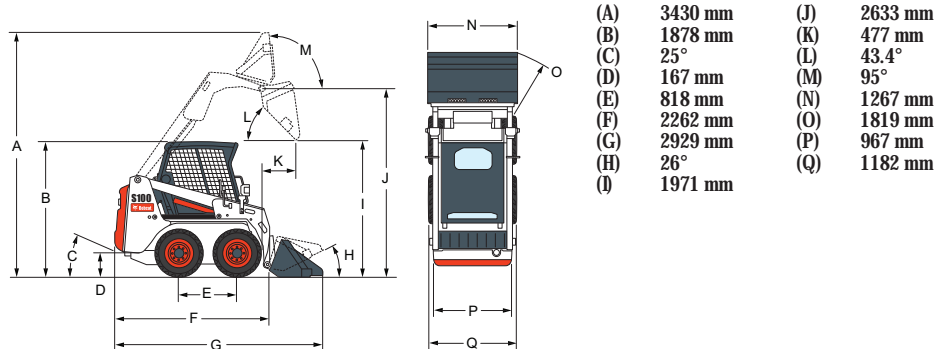

Attachments

- Angle blade (snow blade)
- Angle broom*†
- Auger
- Buckets
- Cutter crusher*
- Digger
- Dumping hopper
- Front scarifier
- Grapples and forks
- Hydraulic breaker**
- Landplane
- Loader X-Change™ frame (for breaker)
- Pallet forks
- Scraper
- Snow blower*
- Soil conditioner*
- Sweeper
- Three-point hitch
- Tiller
- Tilt-Tatch
- Trencher

*Attachment control kit required.

**When operating the loader with this attachment, a Special Applications Kit, which includes a 12 mm Lexan front door with 6 mm top and rear windows, must be used.

†Optional water kit.

Specifications and design are subject to change without notice. - Pictures of Bobcat products may show other than standard equipment.

www.bobcat.eu



Bobcat®

