



Bobcat®

S185

Compact Loaders



Machine Rating

Rated operating capacity	924 kg
Tipping load	1849 kg
Pump capacity	100 l/min
System relief at quick couplers	22.4–23.1 MPa
Max. travel speed (low range)	11.8 km/h
Max. travel speed (high range - option)	17.9 km/h

Engine

Make / Model	Kubota / V2607-DI-TE3B-BC-2
Fuel / Cooling	Diesel / Liquid
Power	43.3 kW
Torque at 1425 RPM (SAE J1 995 Gross)	200.7 Nm
Number of cylinders	4
Displacement	2600 cm ³
Fuel tank capacity	90.8 l

Weights

Operating weight	2821 kg
------------------	---------

Controls

Vehicle steering	Direction and speed controlled by two hand levers
Loader hydraulics tilt and lift	Separate foot pedals or optional Advanced Control System (ACS)
Front auxiliary (standard)	Electrical switch on right-hand steering lever

Drive System

Transmission	Infinitely variable tandem hydrostatic piston pumps, driving two fully reversing hydrostatic motors
--------------	---

Standard Features

High-back cushion suspension seat	Engine/hydraulics system shutdown
Automatically activated glow-plugs	Hydraulic bucket positioning
High flow hydraulics	Instrumentation
Attachment electrical control kit	Lift arm support
7-pin attachment control kit	Operating lights, front and rear
Bob-Tach™ frame	Parking brake
Bobcat Interlock Control System (BICS)	Seat belt
Deluxe operator cab	Seat bar
Includes interior cab foam, side, top and rear windows	Spark arrestor muffler
Electrically activated proportional front auxiliary hydraulics	10 x 16.5, 10-ply, Heavy duty tyres
	CE certification

* Roll Over Protective Structure (ROPS) – meets requirements of SAE-J1040 and ISO 3471; Falling Object Protective Structure (FOPS) - meets requirements of SAE-J1043 and ISO 3449, Level I

Options

Deluxe instrument panel	10 x 16.5, 10-ply, Severe duty poly filled tyres
Power Bob-Tach™	Air conditioning
Cab enclosure with heat	Advanced Control System (ACS)
31 x 12-16.5, 10-ply, Superflotation tyres	Advanced Hand Controls (AHC)
10 x 16.5, 10-ply, Heavy duty tyres, offset rims	Selectable Joystick Controls (SJC)
10 x 16.5, 10-ply, Severe duty tyres	Two speed

Dimensions

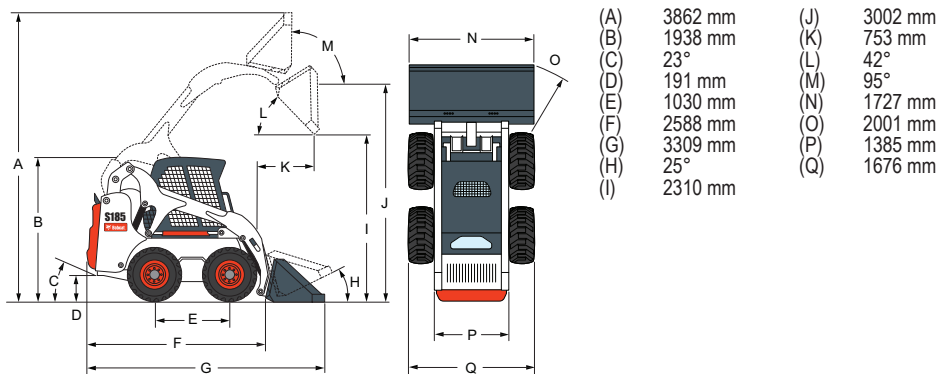

Attachments

- Angle blade
 - Angle broom*†
 - Auger
 - Backhoe
 - Box blade
 - Brushcat rotary cutter
 - Buckets
 - Chipper*
 - Combination bucket
 - Concrete pump*
 - Cutter crusher*
 - Digger
 - Dozer blade*
 - Dumping hopper
 - Farm grapple
 - Grader*
 - Hydraulic breaker**
 - Industrial grapple
 - Landplane
 - Landscape rake
 - Mixing bucket*
 - Pallet fork – standard
 - Pallet fork – hydraulic
 - Planer*
 - Rear stabiliser
 - Scarifier
 - Snow blower*
 - Sod layer*
 - Soil conditioner*
 - Spreader
 - Stump grinder*
 - Super scraper
 - Sweeper
 - Three-point hitch
 - Tiller
 - Tilt-Tatch™
 - Tracks, steel
 - Tree transplanter*
 - Trench compactor
 - Trencher
 - Utility forks
 - Vibratory roller
 - Water kit
 - Wheel saw
 - Whisker broom
- *Attachment control kit required.
 **When operating the loader with this attachment, a Special Applications Kit, which includes a 12 mm Lexan front door with 6 mm top and rear windows, must be used.
 †Optional water kit.



www.bobcat.eu