

SL 1640

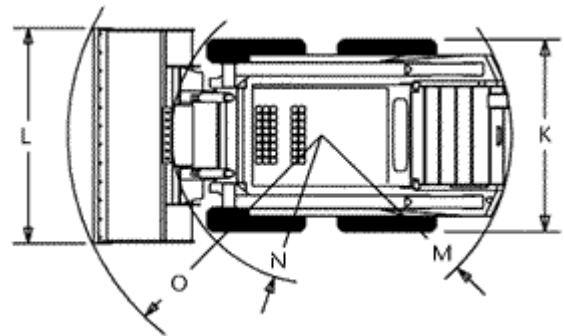

Dimensions		SL 1640
A	Overall operation height-fully raised	3.110 mm
B	Height of hinge pin-fully raised	2.445 mm
C	Overall height	1.810 mm
D	Ground Clearance	170 mm
E	Overall length (with bucket)	2.500 mm
F	Overall length (less bucket)	1.970 mm
G	Wheel base	778 mm
H	Dump reach	410 mm
I	Rollback at ground	26°
J	Dump angle	43°
K	Overall width	5,7x12=890 mm
L	Bucket width	915 mm
M	Clearance circle-rear	1.218 mm
N	Clearance circle-front (less bucket)	902 mm
O	Clearance circle-front (with bucket)	1.508 mm
P	Seat to ground height	
Q	Rollback at full height	
R	Dump height	1.890 mm
S	Departure angle	

Gehlmax Nederland b.v.
 Bruningsstraat 1-3
 4251 LA WERKENDAM
 Tel. 0183 -502311

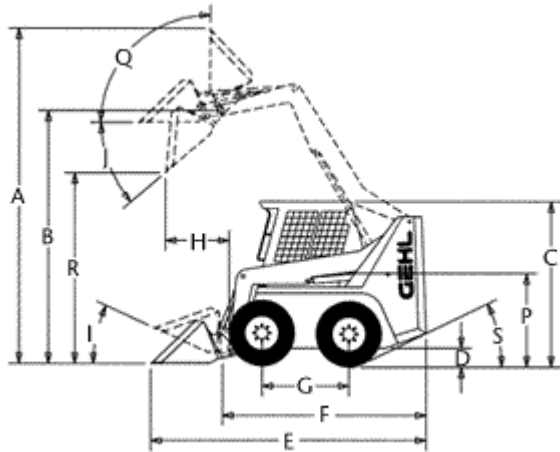

Machine	SL 1640
Operating weight	1.290 kg
Tip capacity	750 kg
Operating capacity	375 kg
Breakout force	1.010 kg
Hydraulic	SL 1640
Loader circuit pump	37 l/min
Loader circuit pressure	175 bar
Hydraulic reservoir	42 litre
Max. travel speed	0 – 9,5 km/h
2-Speed-optional-	no
Standard buckets- width/volume	SL 1640
Standard bucket	1.070 mm / 0,15 m ³
Utility bucket	1.070 mm / 0,22 m ³
Lightmaterial bucket	1.070 mm / 0,30 m ³
Engine	SL 1640
Manufacturer	KUBOTA
Diesel	D 1105
Power output max.	21 HP / 16 KW
At rpm	2.400 rpm
Cylinder / displacement	3/1.123 cm ³
Fuel capacity	36 litre