

SCX2800-2

The New World Standard
Crawler Crane

EUROPEAN ISSUE



Take a closer look. The SCX2800-2. A new standard of 275ton class crawler crane th

From now on, the SCX2800-2 will become a new world standard that matches and answers various demands and requirements from customer around the world. “Higher lifting performance”, “job-proven controllability”, “operator comfort”, “superior safety”, and “transport ease”. The SCX2800-2 takes into its design these points under an advanced and accumulated technologies. Now, the SCX2800-2 just comes around you.

Higher lifting performance

The SCX2800-2. A new world standard crawler crane from Hitachi Sumitomo. No doubt at all. He surely provides superior lifting performance. Designed with two freefall-less main winch drums performing 110m / min rope line speed and 245kN(25t) line pull.

Faster assembling / disassembling design

A self-assembling / disassembling device with a good design of “boom live mast with quick-draw cylinder” and “counterweight self-removal device” is standardized, and it results in saving not only time but also cost whenever such kind of job is done.

Excellent transportability

Further, a transportation ease is available as a 3m overall width is designed even for basic main body when disassembling.



roughout the world.

Max. line pull of
245kN(25t)

Rated line pull of
132kN(13.5t)

High line speed of
110m / min

Engine rated output
272kW(370PS)

Reliable job performance with powerful winch drum

The SCX2800-2 certainly performs liftcrane/luffing towercrane works with bigger line pull of 245kN (25t) as maximum with cable of 28mm diameters.



Bigger drum horse power at widely used rope line speed range

A bigger drum horse power (line pull by line speed) is realized under quite new winch drum design with a specially-tailored power increase control system that maximizes engine output under any load condition in whole range of engine rpm.

Wider drum is designed

Front and rear main operating drums are able to wind up approx. 51m long cable at drum first layer with 26 windings; it accordingly results in longer cable life under a right cable winding into drum.

An aluminum-make oil cooler

For not only corrosion-resistance but also high cooling efficiency, an aluminum-make oil cooler is provided in front of engine radiator.

Optional luffing jib hoist drum

A luffing jib hoist drum is optionally available, and is required when rear main drum is used for liftwork with tower head top sheave machinery in the case of luffing jib application.



Max. lifting capacity:

Liftcrane

275t × 4.3m

Luffing jib

80t × 9.3m

Faster assembling/disassembling of tread members and a good transportability

Boom live mast with quick-draw cylinder and independent counterweight self-removal system

A self-assembling device is standardized with designs of “quick-draw system with boom live mast” and “a full counterweight self-removal device”, for a good, high safety, accuracy assembling / disassembling work under lesser cost in cooperation with “hook-on design” with hydraulic removal joint pins for crawler side frames. Further, for the basic machine, it is able to transport under 45t weight / 3m width as an European road regulation.

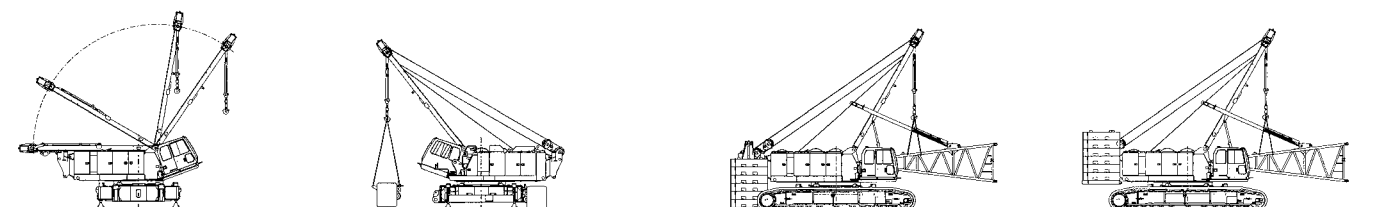

Side frame can be assembled easily under “hook-on design” with hyd. removal joint pins

Thanks to “hook-on design” with hydraulic removal joint pins, crawler side frames can be easily assembled and disassembled on and from car-body frame, and it accordingly results in a time saving task.

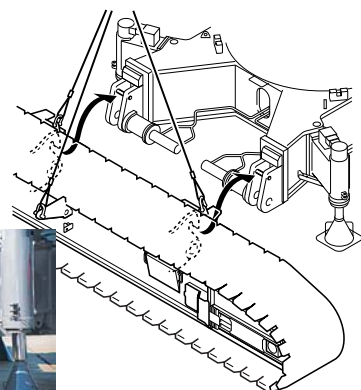

Compact base unit with a total width of 3.0m for transportation

Compact base unit within 3.0 m width is available for transport ease with a swing-away mechanism.



Counterweight with horizontally-split design

It is able to load boom extensions onto counterweight when transport. And, the reversible stack is possible to reduce the time for disassembling/assembling works.



Job-Proven Certain Controllability with simplified & functional control station layout

A high operation ease with specially-tailored EPC system

Thanks to unique EPC system, an easy-precise-minute control of engine rpm and pump discharge from min. thru max. is really possible at the same time by simply pedaling the foot throttle which links "EPC" controller electrically.



Universal joystick control station

An universal joystick control station is provided for a good, easy and comfortable operation for two main operating drums, boom hoist drum and slewing. For travel motion, two armchair control levers are provided behind right-hand universal joystick control lever for operator comfort.

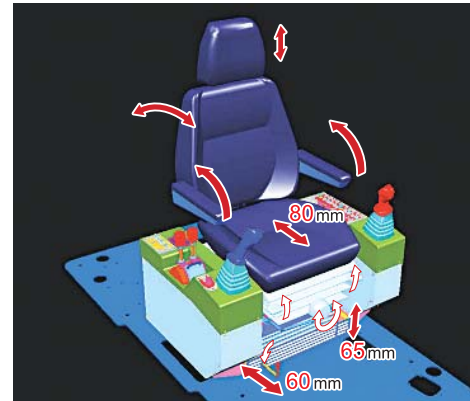

Slidable control station and operator seat

To set most of suitable operator position, both right- and left-hand control stations are designed to simultaneously slide 60 mm back and forth together with operator seat, and operator seat is able to slide 80mm independently too.

A good slewing & boom hoisting/lowering speed control design

Boom hoist drum rotation speed can be freely controlled thru knob dialing independently for more precise combined operation of hook and boom motions. In addition, max. slewing speed can be freely controlled thru knob dialing too, and, as an example, it realizes a precise combined operation under higher hook hoisting and lower slewing speed in high lift work.



A power hydraulically tiltable cab

In consideration of operator comfort, a new operator's cab much improves the visibility thru front and both side windows of the cab under simplified layout of control station. In addition, a power hydraulically tiltable cab is designed for good upward visibility with 20 degree's tilting as max.

Excellent reliability in every safety function

Our own designed new Load Moment Indicator

The Load Moment Indicator (LMI) is reliable computerized safety device developed under our own accumulated technique in the past. An easy-to-read LCD graphic display panel is well designed and a reflection-less display panel is provided on a new LMI with setting ease of viewing angle. In addition, no zero-point adjustment, and data input thru interface counter-indication / message on display panel are available for easier and certain setting of operating conditions and LMI functions. Of course, "present lifting load", "rated load", "load ratio", "working radius", "boom angle", "engine rpm" and so on are indicated on the LMI display panel. Further, displayed picture and menu selection can be easily set up by panel switch in accordance with operation situation and condition.



Lifting height indication function

For more safer lifting work especially in blind condition, it is available to indicate the lifting height above ground or depth below ground on display panel of LMI.





Boom speed slowdown function

This function is available just before automatic stopping of boom motion at both upper and lower side limits of boom angle to prevent a shock even though control lever is still at hoisting/lowering position. This function is also available when overloading in the case that working radius exceeds the specified one.

Dual boom over-hoist limiting device

Further to boom over-hoist limiting function by the limit switch and LMI safety circuit, an additional limit switch is located on boom backstops for redundant boom protection.

LMI automatically sets front-end att. erection mode with letter message

In the range out of crane working area, the LMI display panel automatically indicates “Now, out of crane working range” with a rigging instruction, and it is available to lift front-end att. off ground without the influence of LMI safety functions, and, after front-end att. is lifted over the range of crane working area, LMI safety function gets back automatically for safe erection work.

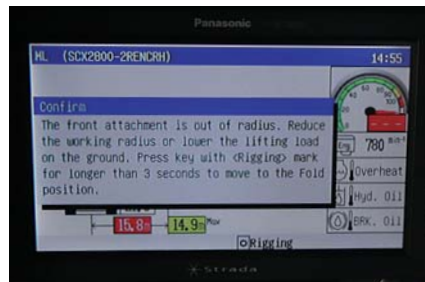

Fool proof shut-off system

To insure safety when the operator leaves the cab, a main hydraulic shut-off switch is located in the cab exit to deactivate and lock the hydraulic system.

Automatic drum pawl locking device

On boom hoist drum, it is designed to automatically lock and release drum pawl when control lever just returns to neutral position, and just actuates.



SCX2800-2

GENERAL DIMENSIONS

Unit : mm

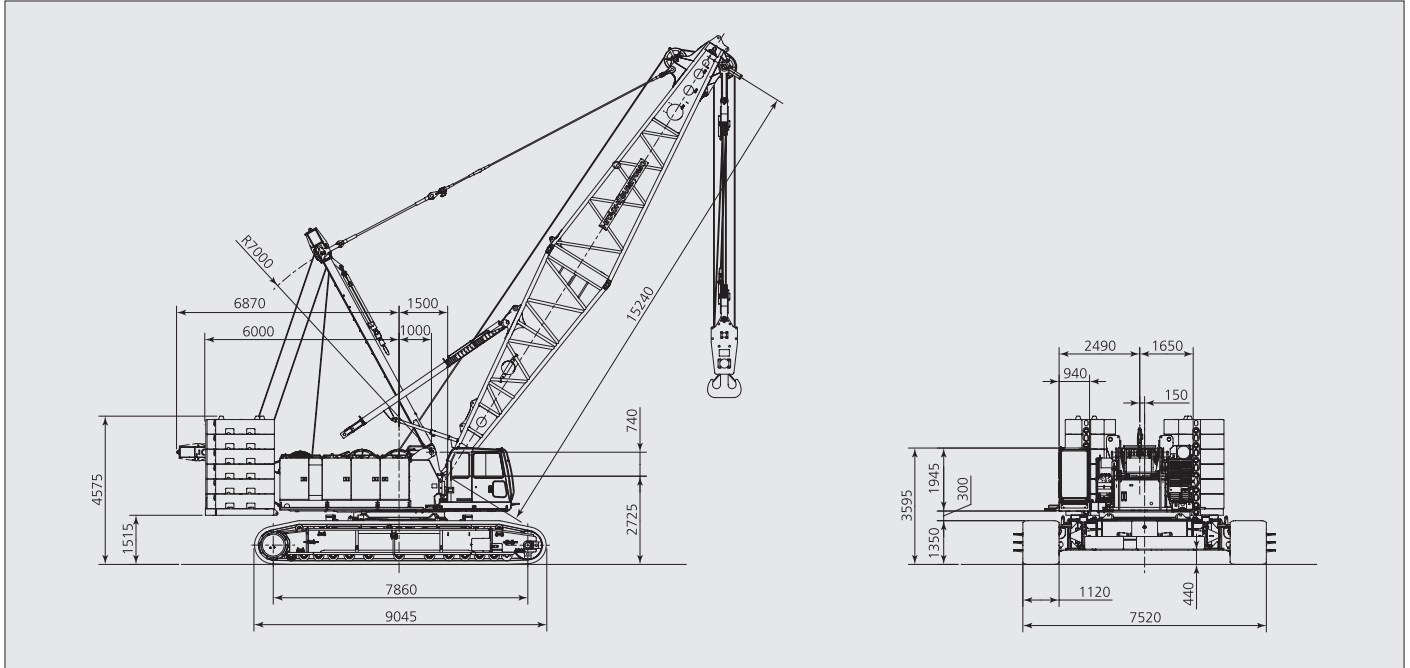

SPECIFICATIONS

		Liftcrane application	Luffing towercrane application
Max. lifting capacity	t × m	275 × 4.3	80 × 9.3
Basic boom length	m	15.25	—
Max. boom length	m	91.45	—
Fly jib length	m	12.20 ~ 36.55	—
Boom + fly Jib length	m	70.10 + 36.55	—
Tower length	m	—	21.35 ~ 60.95
Tower jib length	m	—	21.35 ~ 60.95
Tower + jib length	m	—	60.95 + 60.95
Rope line speed(*1)	Front main drum	m / min	110 ~ 2
	Rear main drum	m / min	110 ~ 2
	Boom hoist drum	m / min	(24 ~ 1) × 2
	Lifting jib hoist drum	m / min	—
Slewing speed	min ⁻¹	1.5	1.5
Travel speed high/low(*2)	km/h	1.1 / 0.5	1.1 / 0.5
Gradeability	%(°)	30 (17)	30 (17)
Engine	Make&model	Mitsubishi 6M70-TL	Mitsubishi 6M70-TL
	Rated output	kW / min ⁻¹	272 / 2000
Ground contact pressure	kPa	124.0	133.4
Operating weight	t	223 (w/15.25basic boom and 275t hook block)	239 (w/60.95m tower, 60.95m luffing jib and 80t hook block)

- Notes:
1. These figures are based on drum first layer and rated engine rpm with no load, and vary under load and operating conditions(*1).
 2. Travel speed is based on flat, level and firm supporting surface, and under the conditions that no load must be applied and front-end attachment must be 15.25m basic boom(*2)
 3. Unit in this specification is each shown under International System of Units.
 4. Liftcrane and luffing jib capacities of this SCX2800-2, are based on European EN13000 Standards.

- We are constantly improving our products and therefore reserve the right to change designs and specifications without notice.
- Illustrations may include optional equipment and accessories, and may not include all standard equipment.
- Painting color other than blue-and-white shown in this catalog shall be optionally available.

Address inquires to:

**Hitachi Sumitomo Heavy Industries
Construction Crane Co., Ltd.**

9-3, Higashi Ueno 6-chome, Taito-ku, Tokyo 110-0015, Japan
Phone : 81-3-3845-1387 Facsimile : 81-3-3845-1394
<http://www.hsc-crane.com>