

VOLVO ARTICULATED HAULERS

A35F_{FS}, A40F_{FS}

33.5-39.0t 447-476hp



A PASSION FOR PERFORMANCE.

At Volvo Construction Equipment, we're not just coming along for the ride. Developing products and services that raise productivity – we are confident we can lower costs and increase profits for industry experts. Part of the Volvo Group, we are passionate about innovative solutions to help you work smarter – not harder.

Helping you to do more

Doing more with less is a trademark of Volvo Construction Equipment. High productivity has long been married to low energy consumption, ease of use and durability. When it comes to lowering life-cycle costs, Volvo is in a class of its own.

Designed to fit your needs

There is a lot riding on creating solutions that are suited to the particular needs of different industry applications. Innovation often involves high technology – but it doesn't always have to. Some of our best ideas have been simple, based on a clear and deep understanding of our customers' working lives.



You learn a lot in 175 years

Over the years, Volvo has advanced solutions that have revolutionized the use of construction equipment. No other name speaks Safety louder than Volvo. Protecting operators, those around them and minimizing our environmental impact are traditional values that continue to shape our product design philosophy.

We're on your side

We back the Volvo brand with the best people. Volvo is truly a global enterprise, one that is on standby to support customers quickly and efficiently – wherever they are.

We have a passion for performance.



Volvo Trucks

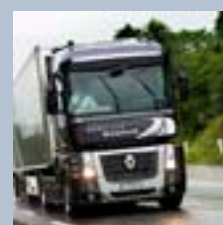

Renault Trucks



Mack Trucks



UD Trucks



Volvo Buses



Volvo Construction Equipment



Volvo Penta



Volvo Aero

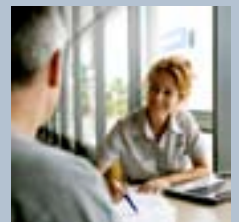

Volvo Financial Services

TAKE CONTROL OF YOUR PRODUCTIVITY.



Volvo's Unique Steering System

The steering system design provides high steering force, even at low engine speeds for the toughest off-road operating conditions, e.g. deep mud. Hydraulic damping prevents the transmission of impacts and jolts to the steering wheel and operator. The system also ensures precise steering and directional stability at high-speed hauling on roads, so there is no need for the operator to compensate with the steering wheel.

A typical work cycle for an articulated hauler includes loading, travel, maneuvering and dumping. The Volvo A35F_{ES} and A40F_{ES} machines perform these operations in the most efficient and safe way, excelling all others.

On Board Weighing (Optional equipment)

OBW-equipped haulers are fitted with indicator lights, mounted on the outside of the machine. This helps load nominal and prevent overloading, avoiding machine and tyre wear as well as excessive fuel consumption. OBW logs all transported loads and the data is displayed on the contronics display. The information can also be accessed remotely, CareTrack, for complete payload management.

Volvo's Unique Load & Dump Brake

The patented user-friendly Load & Dump Brake enhances productivity and safety, improving ease of operation and reducing operator fatigue. When in position for loading or dumping, the operator presses a single button which results in automatic application of the service brakes and shifting the transmission to neutral. Once completed, selecting a gear then deactivates the function, releasing the brakes.



Beneficial Body Design

A strategically located body hinge provides a long distance between the rear bogie axle and the chute's rear edge together with high dump clearance when the body is raised. Allowing placement of the load directly in the right position, it maximizes productivity while dumping over an edge, into a hopper or stockpiling. The high tipping angle and design of the body, made from high strength steel, promote efficient material ejection.

Powerful Hydraulics and Effective Dumping

The load sensing hydraulic system with variable displacement axial-piston pumps, powering the double acting single-stage hoist cylinders, allows easy rising of the fully loaded body even on very steep grades. Precise dumping control ensures short cycle times and safety in all applications.

SMOOTH AND STEADY. ALWAYS.

Off-road hauling performance is enhanced when every wheel is firmly on the ground. Stable and smooth, Volvo haulers keep you moving ahead in full control, even in the worst operating conditions.

Rotating Hitch

The hitch allows independent movement of the tractor and the trailer without frame twist and provides the required oscillation for good ground contact in rough operating conditions. The high hitch position close to the load's center of gravity improves stability and ensures high ground clearance for unique off-road mobility and steady high-speed hauling.



All-Terrain Tires

Tires are an important part of the drivetrain and the articulated hauler concept. Large and wide tires ensure low ground pressure, good floatation and excellent off-road mobility, providing smooth, comfortable ride. F-series machines feature durable radial tires with long service life, designed for hauling applications to ensure good traction and stability.

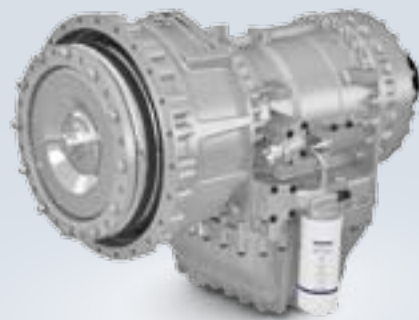

Differential Locks

F-series Volvo articulated haulers are equipped with "dog clutch" type differential locks, featuring 100% locking capability and a no-slip, no-wear design. When locked, all wheels rotate at the same speed, maximizing traction in severe operating conditions. The differential locks can be engaged or disengaged on the move for greater productivity and performance.

Volvo Transmission

Purpose-built by Volvo and newly updated, the Powertronic planetary transmission with lockup function is designed to ensure fully automatic, accurate and smooth gear selection for reduced operator fatigue and increased productivity. The transmission has 9 forward and 3 reverse gears, which can be skipped while shifting for faster acceleration. An integrated transmission protection reduces the risk for operator error, improving safety.



Full Suspension Boosts Productivity

The efficient and reliable 3-point axle mounting, allowing excellent off-road performance, is further improved. The bogie beam and rubber springs are replaced by hydraulic struts on all wheels, which, in combination with hydraulic accumulators and a control unit, form the unique, full hydraulic suspension. On rough haul roads, machines can be driven at higher speeds, whether loaded or empty, shortening cycle times.

OPERATE IN COMFORT.



Volvo Care Cab

Good all-around visibility is essential for both high safety and productivity. Comfortable Volvo Care Cab with centrally positioned operator station, sloping hood, large rear-view mirrors, wide front windshield and a full-glass door feature excellent visibility. A new instrument panel, Contronics and tipping lever ensure ease of operation.

Spacious interior, large storage compartments, conveniently located pedals, controls and switches minimize operator fatigue throughout the whole shift. Optional Electronic Climate Control (ECC) system automatically maintains the desired temperature. The well-designed cab is built from high strength steel, meeting ROPS/FOPS safety standards.

Volvo offers a world-class operator environment for low fatigue, high productivity and safety. Just enter the legendary Care Cab and look around. All instruments are in view, all controls are within reach – right where you want them. The steering wheel and seat can be easily adjusted for optimum comfort.

User-Friendly Operator Communication System

Contronics continuously provides valuable information on the machine's systems and operation, with early warning via easy to understand malfunction indicators, alerting abnormal machine or operator behavior, improving availability. A new large color monitor is visible at a glance and a new keypad, located on the right instrument panel, allow easier navigation between different screens and functions.

Comfort and Performance for Advanced Off-Road Hauling

Volvo's unique Full Suspension system effectively reduces bouncing, shaking and vibration to ensure a smooth and safe ride, providing excellent working conditions for the operator. The levelling sensors constantly monitor the axles' position and the system adjusts the hydraulic struts to keep the whole machine level, ensuring load retention when travelling on uneven ground. The stabilizer function improves dynamics and maximizes the vehicle's stability.



Safe and Easy Cab Access

Designed for safe, easy entry and exit, the Care Cab features a wide door opening with no threshold, correctly positioned non-slip steps and new, convenient handrails.

Dumping Functionality

A35FFs and A40FFs feature new dumping functions, improving ease of operation, safety and productivity – detent body lowering and adjustable tipping angle. The angle can be easily set by the operator, using Contronics to limit the machine height, when operating under electrical wires, in tunnels or underground.

Noise Reduction

The Care Cab features very effective sound insulation and is mounted on optimally positioned rubber pads to reduce vibration. Comfortably low internal noise level (only 74 dB (A) – ISO 6396) reduces fatigue to help boost operator productivity.

LESS MAINTENANCE FOR MORE UPTIME.

Volvo articulated haulers help you get more out of each working day. They feature a low need for maintenance, long service intervals, excellent serviceability and availability. All this contributes to more uptime for productive hauling.

Brake and Retardation Systems

A35Fs and A40Fs are equipped with oil cooled wet multiple disc brakes on all wheels. The design ensures high braking performance and long service life, even on very dusty or muddy sites. Additionally, both machines feature easy to operate retardation system, using the wheel brakes and VEB (Volvo Engine Brake – compression brake plus exhaust retarder EPG). Powerful retarders are used to control speed while hauling downhill, slowing down before curves or cross roads, reducing the need for service brakes use. It ensures low operating costs plus fast and safe hauling.

Service Friendly

Engine oil filters are grouped and easily accessed via the swing-down front grill. The special valve in the belly plate and a dedicated drainage hose, stored in the front grill, ensure oil change without spillage, reducing environmental impact. Remote-mounted drains are located for convenient reach. All service and grease points are easily accessed either from ground level via non-slip platforms. Daily and weekly maintenance is not required. Excellent serviceability and long service intervals reduce machine downtime.



Automatic On-Board Monitoring

The Contronics system electronically monitors fluid levels, providing warnings for any deviations and scheduled service reminders, which minimizes downtime and increases machine availability.

Maintenance Free Rotating Hitch

All F-series haulers feature 100% maintenance free, completely sealed, durable hitch with permanently greased tapered roller bearings. No need for maintenance means reduced downtime and operating costs.



Easy Service Access

The front grill swings down, acting as a service platform with anti-slip steps. The hood tilts up to 90 degrees for full and safe access to the engine compartment. This makes reaching service points, changing filters, cleaning the cooling package much easier and less time consuming.

A QUICK LOOK AT THE BEST HAULER.



CareTrack*

CareTrack is the Volvo telematics system. It is equipped as standard on this machine and is designed to provide information to help improve productivity and efficiency.

Heavy Duty Body

Durable body made from high strength HB400 steel. Body design, high dump clearance and tipping angle promote excellent material ejection.

Powerful Hydraulics and Effective Dumping

Load-sensing "closed-centre" hydraulic system with variable displacement pumps. Easy body raising, even on steep grades. Precise dumping control ensures short cycle times and safety. Detent body lowering and adjustable tipping angle improve productivity.

Durable Frames

Heavy-duty front and rear frames, with optimized load carrying design. Developed for severe off-road operations and long service life.



Differential Locks

No slip, no wear, "dog clutch" type differential locks provide 100% locking capability. "Dog clutch" longitudinal differential lock in drop box.



Full Hydraulic Suspension

Volvo's unique Full Hydraulic suspension on all wheels, with automatic levelling and stabilizer, allows higher speeds on rough haul roads, whether the vehicle is loaded or empty, ensuring increased productivity combined with maximum operator comfort and excellent off-road performance.

Powerful Brakes and Retardation

Oil cooled, multiple wet disc brakes on all wheels ensure high braking performance and long lifetime. Easy to operate, powerful retardation system, using the wheel brakes and VEB, provides low operating costs.



* In markets where CareTrack is available



Volvo Care Cab

Quiet, spacious, comfortable, with excellent visibility and ergonomically positioned controls for safe, productive operation. Meets ROPS / FOPS safety standards.

Unique Load & Dump Brake

Easy to operate: a single button press applies the service brakes and shifts the transmission to neutral, reducing operator fatigue, enhancing productivity and safety.

On Board Weighing

OBW logs all transported loads. The information can also be accessed remotely thanks to Volvo's advanced telematic system, CareTrack. This allows complete payload management.



Easy Service Access

90 degree tilting hood and swing down front grill with integrated steps, acts as a service platform. All grease points and remote mounted drains are accessible from ground level or non-slip platforms. No daily or weekly greasing.



Articulated Steering

Unique, hydro-mechanical, self-compensating system. High steering force, accurate steering, directional stability for productive and safe operation.



Fuel Efficiency

Environmentally-friendly, electronically controlled, powerful diesel engine. High torque at low rpm, well matched drivetrain and ATC reduce fuel consumption.

Maintenance-Free Hitch

Rotating hitch with permanently greased tapered roller bearings eliminates frame twist, providing better off-road mobility. High placement ensures excellent ground clearance and stability.

EFFICIENT HAULING. DEFINED.



"F" Stands for Fuel Efficiency

F-series haulers provide market leading fuel efficiency. Reliable Volvo components, designed using over 40 years experience, competence and the latest industrial technologies are well matched in the drivetrain, specially developed for heavy duty applications. Functioning together, they ensure high rimpull, low power losses and a long service life. Main customer benefits – reduced operating costs and environmental impact.

Customer trust is not just given, but earned over years. Volvo developed the hauler concept in the 1960s and retains its position as the world's leading articulated hauler manufacturer. When choosing A35Fs or A40Fs, you can be sure – the job will be done quickly, cost effectively and safely, with low environmental impact.

Automatic Traction Control (ATC) System is Standard on All F-Series Volvo Articulated Haulers

Constantly changing underfoot conditions are quite common when operating an articulated hauler. To keep the traction and mobility, ATC system automatically selects the optimal drive combination on the move. The possibility to shift between 6x4 mode (lower fuel consumption, less tire wear) and 6x6 mode (maximum rimpull) is a Volvo exclusive.

Since operators do not have to engage/disengage differential locks manually, they can focus on proper operation, which improves safety and reduces operating costs. The ATC system not only simplifies operation, maximizing off-road performance, but also protects the drivetrain from misuse and unnecessary wear, prolonging machine service life.



Environmentally-Friendly Engine

A35Fs and A40Fs are equipped with electronically controlled, low emission diesel engines. Powerful engines are characterized by high torque at low rpm, resulting in excellent fuel efficiency, high performance, quick response, less wear and long life. Purpose built by Volvo, they optimally match the drivetrain, ensuring maximum utilization of power and torque even in the most demanding applications.

Effective Cooling

Two hydraulically driven variable speed fans consume engine power only when needed, perfectly responding to cooling demands. Most of the time, they rotate at idle speed, lowering fuel consumption and noise. The system ensures effective cooling, providing optimal temperatures in all conditions. Side-mounting simplifies service, maximizing uptime.

TOP PERFORMANCE DESERVES SUPPORT.

The day you receive your new Volvo Articulated Hauler is just the start of your working relationship with Volvo. From service and maintenance to our CareTrack telematics system – Volvo has a comprehensive and sophisticated aftermarket portfolio to continuously add value to your business.

Volvo designed and built your machines, so no-one knows how to keep them working in top condition more than us. When it comes to your machine, our Volvo trained technicians are the experts.

Our technicians work with industry leading diagnostic tools and techniques, using only Genuine Volvo Parts to deliver the highest levels of quality and service. Talk to your Volvo dealer about how genuine Volvo services can best provide the service and maintenance plan that is the right fit for you and your business.



State-of-the-art machines require state-of-the-art support and your Volvo dealer can provide a catalogue of services designed to get the most out of your machine, helping you maximise uptime, productivity and residual value. Your Volvo dealer can provide a number of sophisticated support offers, including:

Service plans ranging from routine wear inspections, through to comprehensive maintenance and repair agreements.

Analysis and diagnostics to help you understand how your machine is running, highlight potential maintenance issues and identify where performance can be improved.

Eco Operator training courses can help your operators work towards a safer, more productive and fuel efficient performance.



CareTrack*

Each Volvo Articulated Hauler comes standard equipped with CareTrack, the Volvo telematics system. CareTrack provides information for better planning and smarter working; including fuel consumption reports, location reports and service reminders. Save fuel. Reduce costs. Maximise profitability. You can with CareTrack.

* In markets where CareTrack is available

VOLVO A35F_{FS}, A40F_{FS} IN DETAIL.



Engine

Fuel efficient, powerful, low-emission, 6-cylinder, straight turbocharged diesel engine with 4 valves per cylinder, overhead camshaft and electronically controlled unit injectors. High torque at low rpm. Long service life.

The engine features wet replaceable cylinder liners, replaceable valve guides and valve seats.

Two-stage incoming air filtration is standard.

Cooling system: high capacity cooling system with easy accessible, power and fuel saving, variable speed hydraulically driven fans.

A35F_{FS}		Volvo D13F-A
Max power at	r/s	31.7
SAE J1995 Gross	kW	329
Flywheel power at	r/s	31.7
ISO 9249, SAE J1349 Net	kW	327
Max torque at	r/s	20
SAE J1995 Gross	Nm	2 360
ISO 9249, SAE J1349 Net	Nm	2 345
Displacement	l	12.8

A40F_{FS}		Volvo D16F-A
Max power at	r/s	30
SAE J1995 Gross	kW	350
Flywheel power at	r/s	30
ISO 9249, SAE J1349 Net	kW	347
Max torque at	r/s	17.5
SAE J1995 Gross	Nm	2 525
ISO 9249, SAE J1349 Net	Nm	2 500
Displacement	l	16.1

Drivetrain

Torque converter with built-in lock-up function.

Transmission: Volvo PowerTronic planetary fully automatic transmission with 9 forward gears and 3 reverse gears.

Dropbox: Volvo-developed, in-line design with high ground clearance and 100% longitudinal "dog clutch" type differential lock.

Axles: heavy duty, purpose built Volvo design with planetary type hub reductions and 100% "dog clutch" type differential locks.

Automatic traction control system (ATC).

A35F_{FS}/A40F_{FS}

Torque converter	2.1:1
Transmission, Volvo	PT 2519
Dropbox, Volvo	IL2 ATC
Axles, Volvo	ARB H35/H40

Electrical System

Cables are enclosed in protective plastic conduits, secured to the frame.

All cables, sockets and pins are identified. Prewired for options.

Connectors meet IP67 standard for water-proofing.

Easy accessed battery disconnect switch.

Powerful halogen lights.

A35F_{FS}/A40F_{FS}

Voltage	V	24 (2x12)
Battery capacity	Ah	2x170 / 2x225
Alternator	kW (A)	2.26 (80)
Starter motor	kW	9.0



Brake System

Complies with ISO 3450.
Fully hydraulic, wet brakes with enclosed, oil-cooled multiple discs on all wheels. Separate brake cooling for each axle.
Two independent circuits: one for front axle and one for bogie axles.
Parking brake: spring-applied disc brake on the propeller shaft.
Retarders: using wet brakes in axles and Volvo Engine Brake.
Volvo Engine Brake: compression brake and exhaust retarder (EPG).

Steering System

Hydro-mechanical, self compensating design. Two double-acting steering cylinders.
Steering angle: 3.4 steering wheel turns lock-to-lock, $\pm 45^\circ$.
Steering system, including secondary steering fulfills ISO 5010.

Chassis

Frames: box type, heavy duty. High strength steel, robot welded.
Rotating hitch: 100% maintenance free, fully sealed, with permanently greased tapered roller bearings.

Suspension

Unique, full hydraulic, on all wheels with automatic leveling and stabilizer. Part of the machine's hydraulic system, uses the same hydraulic oil.

A35Ffs/A40Ffs

Hydraulic cylinders (struts), front/rear	2/4
Accumulators, oil-nitrogen, high pressure, front	2
Accumulators, oil-nitrogen, high/low pressure, rear	2/2
Levelling sensors	2+2+2

Cab

Mounted on rubber pads. Ergonomically designed. Easy entry and exit. Wide angle forward view. Operator centrally positioned above the front axle. Adjustable operators seat with retractable seat belt. Tilt/telescopic steering wheel. Ergonomically positioned controls. Heating and ventilation system with all windows defroster. Filtered air. Optional automatic climate control (ACC).
Operator communication system: Contronics. Large color display, user-friendly and easy-to-understand information, all vital machine functions are constantly monitored.
Instructor seat with seat belt.
Safety: ROPS/FOPS standards approved according to ISO3471, SAE J1040 / ISO3449, SAE J231.
Sound level in cab according to ISO 6396: 74 dB(A).
External sound level* according to ISO 6395: 110 dB(A).

* with Noise Reduction Kit

Hydraulic System

Pumps: Six engine-driven variable displacement piston pumps driven by the flywheel PTO. One ground-dependent piston pump mounted on the dropbox for emergency steering.
Two return oil filters with magnetic cores provide effective oil filtration.
System max pressure is 25 MPa.
Full suspension system max pressure is 23.5 MPa.

Dumping System

Patented Load and Dump Brake.
Dumping Cylinders: two single stage double acting.

A35Ffs/A40Ffs

Tipping angle	°	72/70
Tipping time with load	s	12
Lowering time	s	10

Body

Plate thickness:		
Front	mm	8
Sides	mm	12
Bottom	mm	14
Chute	mm	16
Material: HB400 steel		
Yield strength	N/mm ²	1 000
Tensile strength	N/mm ²	1 250

Load Capacity

	A35Ffs	A40Ffs	
Standard Body			
Load capacity	kg	33 500	39 000
Body, struck	m ³	16.0	18.4
Body, heaped 2:1	m ³	20.5	24.0
With overhung tailgate			
Body, struck	m ³	16.4	18.8
Body, heaped 2:1	m ³	21.4	24.7

SPECIFICATIONS.

Fill capacities			
		A35Ffs	A40Ffs
Crankcase	l	50.0	54.0
Fuel tank	l	480.0	545.0
Cooling system	l	95.0	95.0
Transmission, total	l	45.5	45.5
Dropbox	l	9.2	9.2
Axles, front/bogie	l	28.0/57.0	29.0/59.0
Brake cooling tank	l	121.0	121.0
Hydraulic tank	l	262.0	262.0

Speed			
		A35Ffs	A40Ffs
Forward			
1	km/h	6	6
2	km/h	9	9
3	km/h	11	10
4	km/h	15	15
5	km/h	22	22
6	km/h	28	27
7	km/h	37	36
8	km/h	49	48
9	km/h	57	57
Reverse			
1	km/h	7	7
2	km/h	10	9
3	km/h	18	18

Operating weight unloaded			
		A35Ffs	A40Ffs
Tires		26.5R25*	29.5R25**
Front	kg	15 400	16 400
Rear	kg	13 700	14 600
Total	kg	29 100	31 000
Payload	kg	33 500	39 000

Total weight			
		A35Ffs	A40Ffs
Tires		26.5R25*	29.5R25**
Front	kg	18 400	20 400
Rear	kg	44 200	49 600
Total	kg	62 600	70 000

Operating weight includes all fluids and operator

*) A35Ffs with tires 775/65R29, add 200 kg/axle

**) A40Ffs with tires 875/65R29, add 300 kg/axle

Ground Pressure					
		A35Ffs		A40Ffs	
Tires		26.5R25	775/65R29	29.5R25	875/65R29
Unloaded					
Front	kPa	130	110	117	99
Rear	kPa	58	49	52	45
Loaded					
Front	kPa	156	131	146	122
Rear	kPa	187	157	177	148

Pos	A35Ffs	A40Ffs
	mm	
A	11 180	11 263
A ₁	5 476	5 476
A ₂	6 241	6 404
B	5 540	5 821
C	3 621	3 673
C ₁	3 546	3 597
C ₂	1 772	1 772
D	3 101	3 101
D ₁	2 941	2 942
E	1 277	1 277
F	4 578	4 518
G	1 820	1 940
H	1 683	1 706
I	650	495
J	2 995	3 154
K	2 314	2 457
L	900	844
M	7 248	7 287
N	8 853	8 967
N ₁	4 395	4 307
O	3 106	3 374
O**	3 304	3 497
P	2 870	3 074
Q	2 553	2 730
R	579	635
R ₁	604	644
S	2 422	2 653
T	3 401	3 462
U	3 516	3 565
V	2 534	2 636
V*	2 625	2 709
W	3 258	3 433
W*	3 410	3 570
X	521	571
X ₁	617	671
X ₂	754	807
Y	2 534	2 636
Y*	2 625	2 709
Z	3 258	3 433
Z*	3 410	3 570
a ₁	23.6°	25°
a ₂	72°	70°
a ₃	45°	45°

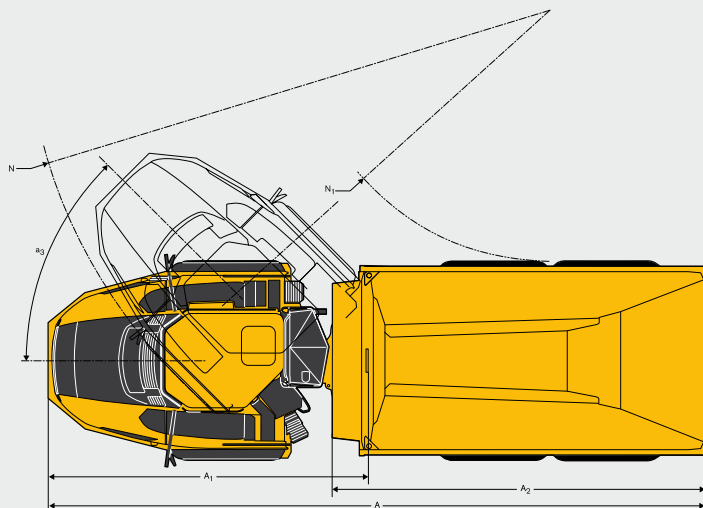
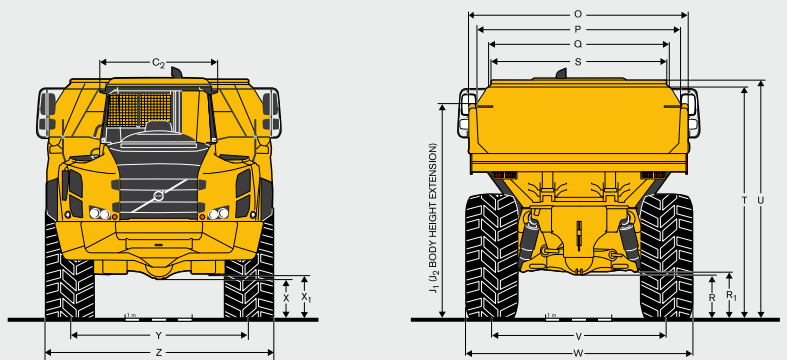
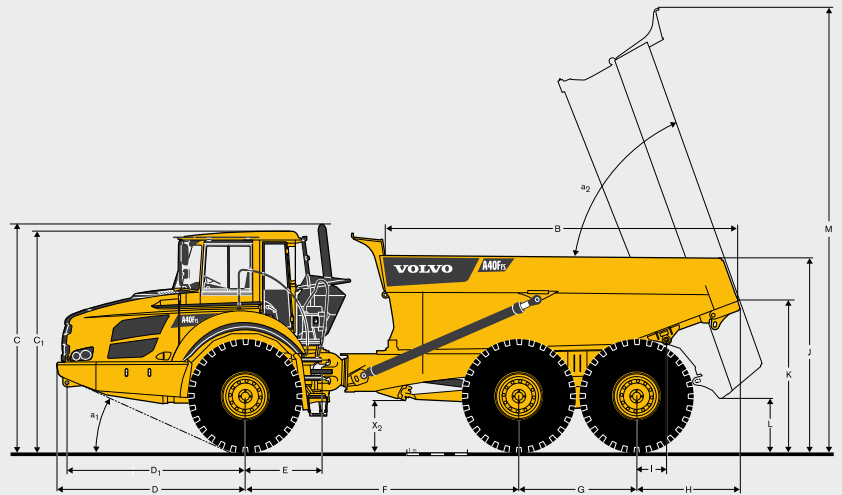

A35Ffs: Unloaded machine with 26.5R25
A40Ffs: Unloaded machine with 29.5R25
*) A35Ffs with optional 775/65R29 tires;
A40Ffs with optional 875/65R29 tires.
**) with overhung tailgate.

EQUIPMENT.

STANDARD EQUIPMENT

	A35Frs	A40Frs
Safety		
Anti-slip steps and platforms	•	•
Dump body lock	•	•
Handrails on steps and platforms	•	•
Hazard lights	•	•
Horn	•	•
Protective grill for cab rear window	•	•
Rear-view mirrors	•	•
Retractable 3-inch safety belt	•	•
ROPS/ FOPS protected Care Cab	•	•
Secondary steering	•	•
Steering joint lock	•	•
Windshield washers	•	•
Windshield wipers with interval function	•	•

Drivetrain

6x4 and 6x6 automatically engaged drive modes	•	•
"Dog clutch" type 100% diff-locks in all axles	•	•
Full automatic transmission	•	•
Single stage dropbox with longitudinal diff-lock	•	•
Torque converter with automatic lock-up	•	•

Engine

Direct injected, electronically controlled, turbocharged, intercooled	•	•
Grouped oil filters, for ease of change	•	•
Preheater for easier cold starts	•	•
Remote oil drain valve and hose for easy access	•	•
VEB (exhaust retarder EPG + compression brake)	•	•

Electrical system

80 A alternator	•	•
Battery disconnect switch	•	•
Extra 24 V socket for lunch cooler	•	•
Lights:		
- Back-up light	•	•
- Brake lights	•	•
- Cab lighting	•	•
- Direction indicators	•	•
- Headlights	•	•
- Instrument lighting	•	•
- Parking lights	•	•
- Rear lights	•	•

Brake system

Load & Dump Brake	•	•
Parking brake on propeller shaft	•	•
Two circuit, fully hydraulic brakes with enclosed, oil-cooled multiple discs on all axles	•	•

	A35Frs	A40Frs
Comfort		
Ashtray	•	•
Cab heater with filtered fresh air and defroster	•	•
Can holder /storage tray	•	•
Cigarette lighter	•	•
Instructor seat with seat belt	•	•
Overhead console for radio	•	•
Sliding window	•	•
Space for lunch cooler	•	•
Storage box	•	•
Sun visor	•	•
Tilt/telescopic steering wheel	•	•
Tinted glass	•	•

Operator information interface

Gauges:		
- Brake pressure	•	•
- Fuel	•	•
- Speedometer	•	•
- Tachometer	•	•
- Wet disc brakes cooling oil temperature	•	•

Warning lights grouped and easy to read

Central warning (3 levels) for all vital functions	•	•
--	---	---

Central positioned information display:

- Automatic pre-start checks	•	•
- Clock	•	•
- Hour meter	•	•
- Operational information, easy-to-navigate menu	•	•
- Troubleshooting diagnostics	•	•

Body

Body prepared for exhaust heating and optional equipment	•	•
--	---	---

Exterior

Front mudguard wideners and rear mudflaps	•	•
---	---	---

Tires

26.5R25	•	
29.5R25		•

Service and maintenance

CareTrack telematics system	•	•
Drainage hose stored in the front grill	•	•
Machine Tracking Information System MATRIS	•	•
Service platform integrated in the front grill	•	•
Tool box	•	•

OPTIONAL EQUIPMENT

	A35Ffs	A40Ffs
Safety		
Fire-extinguisher and first aid kit	•	•
Warning triangle	•	•
Engine		
Air pre-cleaner, cyclone type	•	•
Air pre-cleaner, heavy-duty, dry type EON	•	•
Air pre-cleaner, oil bath type	•	•
Diesel engine heater, Eberspächer	•	•
Electric engine heater (120V or 240V)	•	•
Engine automatic shutdown	•	•
Engine shutdown timer	•	•
External emergency engine stop	•	•
High engine idle speed	•	•
Electrical system		
Anti-theft system (prevents engine start)	•	•
Rear vision system, colour LCD monitor in the cab	•	•
Reverse alarm	•	•
Rotating warning beacon, collapsible mount	•	•
Working lights, front-facing, roof mounted	•	•
Working lights, rear-facing, fender-mounted	•	•
Cab		
Air suspended, heated, fully adjustable seat	•	•
Armrest for operator seat	•	•
Cable kit for cab heater (120V or 240V)	•	•
Electrically heated and adjustable rear view mirrors	•	•
Electronic Climate Control (ECC)	•	•
Head restraint for operator seat	•	•
HEPA cab air filter	•	•
Radio installation kit, including loudspeakers	•	•
Radio with CD player	•	•
Body		
Exhaust heating	•	•
Extra front spillguard, bolt-on	•	•
Light material extension, bolt-on kit	•	•
Overhung tailgate, wire or linkage operated	•	•
Side extensions 200 mm (8"), welded	•	•
Underhung tailgate, linkage operated	•	•
Wear plates for heavy duty applications	•	•
Tires		
775/65R29	•	
875/65R29		•
Service and maintenance		
Automatic lubrication system	•	•
Electrical hood opening	•	•
Tool kit with tire inflation unit	•	•
Other		
On Board Weighing (OBW)	•	•
Arctic kit	•	•
Fast fuelling system, bolt-on kit	•	•
Lifting tools, wheel mounted	•	•
Siberian kit, -40°C	•	•
Synthetic hydraulic oil (biologically degradable)	•	•

SELECTION OF VOLVO OPTIONAL EQUIPMENT

Wear plates for heavy duty applications



On Board Weighing (OBW)



Electrically heated and adjustable rear view mirrors



Rear facing working lights, fender mounted



Rotating warning beacon



Head restraint for operator seat



VOLVO CONSTRUCTION EQUIPMENT

Volvo Construction Equipment is different. Our machines are designed, built and supported in a different way. That difference comes from an engineering heritage of over 175 years. A heritage of thinking first about the people who actually use the machines. About how to help them be safer, more comfortable, more productive. About the environment we all share. The result of that thinking is a growing range of machines and a global support network dedicated to helping you do more. People around the world are proud to use Volvo.

Not all products are available in all markets. Under our policy of continuous improvement, we reserve the right to change specifications and design without prior notice. The illustrations do not necessarily show the standard version of the machine.

VOLVO

Volvo Construction Equipment
www.volvoce.com

Ref. No 20026510-B
2012.04
Volvo, Global Marketing

English-30
ART