

VOLVO ARTICULATED HAULER

T450D SCRAPER HAULER



MORE CARE. BUILT IN.



VOLVO T450D SETS NEW STANDARD FOR SCRAPER HAULERS

Volvo Construction Equipment is a market leader and has set the standard for construction machines. Using our expertise in the construction industry as a platform, we have developed a hauler for pulling scrapers. The Volvo T450D is a highly productive machine where Volvo's proven quality meets creative thinking.

Moving dirt and filling profitably and effectively, e.g., for road construction or site preparation, requires machines based on advanced engineering, accurate calculations and a mindset for quality.

The goal of the development work for the Volvo T450D has been the highest possible productivity. The way to reach that goal was to combine the values for which the name Volvo stands: operating reliability, comfort, performance, operating economy and environmental thinking.

We are convinced that we have succeeded once again. However, as usual, we leave it up to our customers to set the final grade.

Speed and performance.



Construction grade availability.



Easy access for more uptime.



High comfort and excellent operator environment.





GO AHEAD. COMPARE US TO THE REST.

There is only one way to make the right choice: a thorough comparison of the alternatives and making up your own mind. The Volvo T450D wins everytime in a comparison with alternatives for moving and distributing dirt.

The explanation is simple. We have an advantage compared to the rest. Volvo Construction Equipment has manufactured articulated haulers since 1966. Throughout the years, we have refined and developed technology, function and productivity. Satisfied customers and awards, such as the prestigious German Red Dot Award for best design, have spurred us on in our continuous development work.

And, not only have we continued with our usual development work, we have also used the basic design of the articulated hauler to create something new: The Volvo T450D, a rugged scraper hauler with low operating costs, purpose-built for construction work.

Don't waste time and money

There's definitely a difference between planned and unplanned downtime. But they have something in common. All downtime costs time and money. And we've worked to eliminate any waste of time and money.

The Volvo T450D is built for maximal availability. With a rugged design that's taken the best from our long experience of development work with articulated haulers, we have created the optimal conditions for a productive machine with long operating life and good operating economy.

But we don't stop at machine performance and productivity. Other factors contribute to profitability, which all together give major competitive advantages. There are many advantages, but let us highlight a few that we think are extra important.

Main advantages

- **Power**
The Volvo T450D is equipped with Volvo's powerful 12 liter six cylinder, low-emission engine with turbo-charger and intercooler. An all-Volvo drivetrain, with Volvo developed components, gives unique harmony and performance, down to the smallest detail. Power means flexibility. The Volvo T450D can pull up to three scrapers depending on scraper configuration and total weight.
- **Speed**
The machine's stability and engine power make it possible to operate at speeds up to 32 mph (50 km/hour).
- **Productivity**
A long wheelbase gives better traction, which in turn gives faster load cycles and less tire wear. The ergonomically designed operator's cab makes it a safe, comfortable and effective workplace. The Volvo



T450D is designed specifically for the construction market. The rugged design means long operating life and high availability. All this combines to give a high resale value.



Maximum availability

- **Service intervals**
During the design process, we placed great emphasis on reducing maintenance requirements and creating a machine with long service intervals. This saves both time and money.
- **Service-friendly**
Fewer and easily accessed service points make service easier. Contronic, an electronic information system, checks various fluid levels and reports when maintenance should be done.
- **Parts**
With Volvo's global dealer network, you always have access to spare parts and specially trained service technicians when you need them.
- **Service and repair agreements**
Volvo Customer Support offers advantageous service and support agreements, which means even higher machine availability and also a higher resale value.

COMFORT IS NOT A LUXURY - IT'S PROFIT.

Despite all the technological advancements, it's still the operator that does the job, and the machine is the tool. That means that high comfort is not a luxury – it's a requirement for high productivity and good economy.

One important detail can be seen already from the outside. The operator cab's large windows in combination with sloped and rounded hoods give superior visibility for transporting and when loading. The rest has to be discovered from the inside.

The operator's cab for the Volvo T450D is of ergonomic design and adapted for operating with scrapers. One example is the Scraper mode that automatically controls the speed for the most efficient loading. We also designed an armrest panel with high-precision user-friendly "paddle levers," as well as a matched side panel for the Detent function, a time and flow-controlled hold function.

Both the front and rear window have windshield wipers and the operator's seat can be turned 25 degrees to the right, giving the operator full control of both the tractor and the scraper.

The operator's cab is placed over the front axle, exposing the operator to only a minimum of tiring movements. You get the same benefit from Volvo's maintenance-free, three-point suspension. The operator's seat has air suspension and the steering wheel is adjustable, making those really long shifts a little easier.

Further, the Volvo T450D is also equipped with a climate control system that supplies cooling and heating when it's needed the most.

Still, it's difficult with words to do justice to the comfort and work environment in the Volvo T450D. It has to be experienced. And when you've done that, then you'll understand our philosophy of operator comfort not being a luxury.





THE VOLVO T450D IN DETAIL

Volvo's Scraper haulers are equipped with a well-matched drivetrain for optimal use of engine power, torque and rimpull. Correctly matched and Volvo-designed drivetrain components, specifically developed for heavy construction applications, provide outstanding performance, high productivity, low fuel consumption and ensure long machine life.

Serviceability

- 1 No daily or weekly service.**
The Contronic information system monitors all fluid levels, minimizing daily and weekly service times. Time to next service and the status of vital vehicle systems is shown to the operator on a display in the instrument panel.
- 2 Excellent Serviceability**
Swing-down front service platform with access ladder to remote filter bank, located in front of engine. Grouped engine filters and remote-mounted drains reduce service time. Large, 90° electrically opened hood for total engine access.

Productivity and Performance

- 3 High-Performance Low-Emission Engine**
The Volvo inline 12 liter 6-cylinder, direct injected, electronically-controlled, turbocharged and intercooled 4-stroke diesel engine generates high torque at low rpm for quick response and low exhaust emissions that meet existing requirements.
- 4 High-Capacity Cooling System**
Power and fuel saving, hydraulically driven, well-protected, side-mounted variable speed fan consumes power only when needed.
- 5 Volvo Drivetrain**
Correctly matched Volvo-designed components, specifically developed for construction applications. Low power losses and long service life.
- 6 Brakes and Retarders**
Dual-circuit, wet-disc, oil-cooled service brakes on all wheels for maximum safety. Quickcoupler block with connection for scraper brake system. An easy-to-use, variable hydraulic transmission retarder reduces service brake wear and operating cost.
- 7 Purpose-built, 2 speed dropbox**
Optimized rimpull and speed in all operating conditions.
- 8 Volvo's unique Self-Compensating Hydro-Mechanical Steering**
Easy high-speed driving and steering accuracy promoting productivity. Fast-acting, powerful steering with 3.4 turns lock-to-lock for maneuverability in rough conditions. Gives operator "Feel of the Road."
- 9 State-of-the-art Hydraulic System**
Variable displacement piston pumps consume power only as required. One ground-dependent piston pump for secondary steering mounted on the dropbox.
- 10 The scraper hydraulics include a six section, fully proportional control valve with detent function. All connections to the scrapers are included in two fully sealed quick connect blocks.**

- 11 Rotating Hitch**
Rotating hitch and articulated steering provide good traction, off-road mobility and less stress on the frames in tough applications. High-positioned hitch provides great stability.
- 12 Heavy-Duty Axles**
Purpose-built Volvo design with fully floating axle shafts, planetary type hub reductions and 100% dog-clutch type diff lock reduces wheel spin and loading time.
- 13 4x4 with Five Operating Modes**
Five user-friendly drive combinations for every type of operating condition, increases off-road mobility, reduces fuel consumption, drivetrain and tire wear. Operator-selectable on the move.
- 14 Maintenance-Free Suspensions**
Front axle has independent wheel movement via a 3-point mounting system, consisting of rubber springs and shock absorbers. The rear axle has a flexible 3-point rubber mounting.

Low operating cost

All main components for our tractors are developed in-house by Volvo, including the drivetrain, frame, cab, electronics and software. This generates results: higher productivity, higher reliability and service friendliness. All working together to reduce operating cost.



Operator Comfort and Safety

15 Excellent Operator Environment

The Volvo cab is a safe, comfortable, efficient and ROPS/FOPS-certified operator environment, ergonomically designed for high operator comfort and great wide-angle forward visibility. Wide threshold-free door opening and ergonomic cab entrance. Operator positioned above the front axle and in the center of the machine, together with the spacious and comfortable cab contributes to high productivity from the beginning to the end of the shift. Operator's seat can be turned 25 degrees, giving the operator full control of both the tractor and the scrapers. Ergonomically positioned controls, air-conditioning, adjustable operator's seat with retractable seat belt and tilt/telescopic steering wheel for reduced operator fatigue and high safety. Filtered fresh air, four-speed fan and pressurized cab to maintain a clean operating environment.

16 Operator Communication System

The user-friendly, Contronic operator's communication system provides simple and easy-to-understand information. All vital machine functions are constantly monitored and specific system information is displayed if a problem occurs. Service technicians can increase their diagnostic efficiency by using the Contronic service display or Matris software to download operating information stored in the Contronic system. With Volvo's telematic system CareTrack, all this information is available on a dedicated, password protected website accessible from any computer.

SPECIFICATIONS

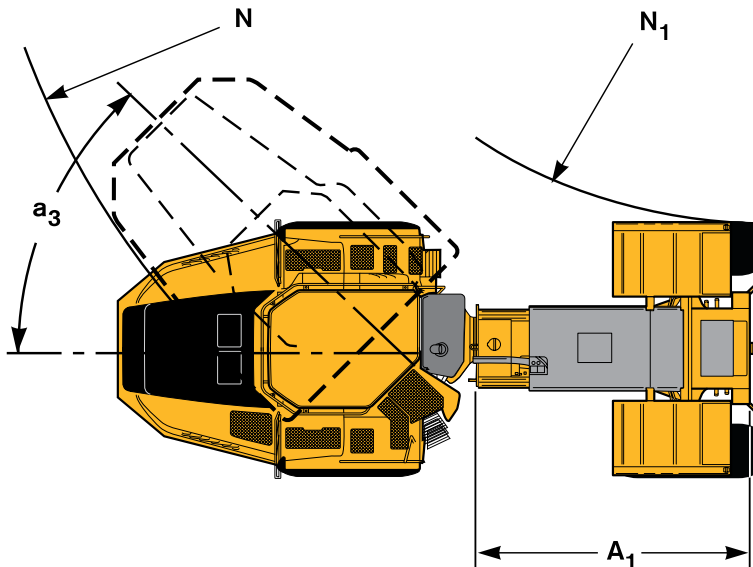
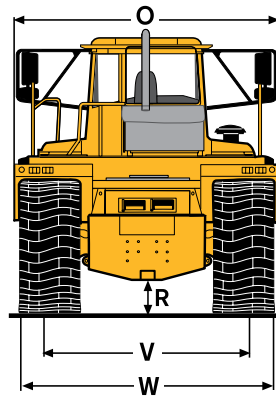
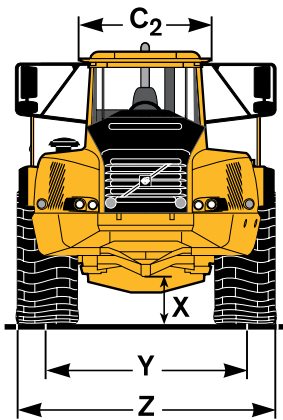
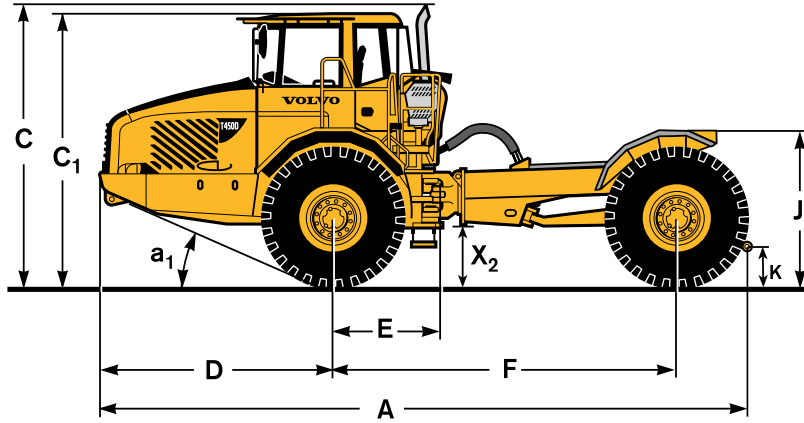

Pos	Metric	Imperial
	Volvo T450D	
A	8 479	27'10"
A ₁	3 753	12'42"
C	3 746	12'3"
C ₁	3 626	11'11"
C ₂	1 768	5'10"
D	3 100	10'2"
E	1 276	4'2"
F	4 451	14'7"
J	2 052	6'9"
K	515	1'8"
N	7 496	24'7"
N ₁	4 238	13'11"
O	3 295	10'10"
R	473	1'7"
V	2 636	8'8"
W	3 432	11'3"
W*	3 570	11'9"
X	617	2'2"
X ₂	756	2'6"
Y	2 636	8'8"
Z	3 432	11'3"
Z*	3 570	11'9"
a ₁	25°	25°
a ₃	45°	45°

T450D: Unloaded machine with 29.5R25

*) T450D with optional 875/65R29 tires

Remaining Optional Tires

Weights	
Tires	T450D 29,5/R25
Operating weight unloaded	
Front	15 180 kg 33 466 lb
Rear	8 420 kg 18 563 lb
Total	23 600 kg 52 029 lb

Operating weight includes all fluids and operator
T450D with optional 875/65R29 tires, add 300 kg
(661lb) /axle.

Load Capacity	
T450D	
Drawbar	
Vertical Load	max. 13 000 kg 28 660 lb
Total weight (Scrapers without brakes)	95 000 kg 209 439 lb

Speed		
Forward, low gear		
	1	6 km/h (4.0 mph)
	2	9 km/h (6.0 mph)
	3	16 km/h (10.0 mph)
	4	24 km/h (15.0 mph)
	5	31 km/h (19.0 mph)
	6	41 km/h (25.0 mph)
Automatic upshift to 6th gear, High range		
	6	55 km/h (34.0 mph)
Forward, high gear		
	1	9 km/h (6.0 mph)
	2	13 km/h (8.0 mph)
	3	23 km/h (14.0 mph)
	4	33 km/h (20.0 mph)
	5	42 km/h (26.0 mph)
	6	55 km/h (34.0 mph)
Reverse, low gear		
	1	6 km/h (4.0 mph)
	2	10 km/h (6.0 mph)
Reverse, high gear		
	1	8 km/h (5.0 mph)
	2	14 km/h (9.0 mph)

Engine

T450D

Make, model	Volvo D12D ABE3**
Max power at	30 r/s (1 800 r/min)
SAE J1995 Gross	313 kW (419 hp)
Flywheel power at	30 r/s (1 800 r/min)
SAE J1349 Net, DIN 6271***	309 kW (414 hp)
Max torque at	20 r/s (1 200 r/min)
SAE J1995 Gross	2 100 Nm(1549 lb ft)
SAE J1349 Net, DIN 6271***	2 056 Nm(1517 lb ft)
Displacement total	12 l (732 in ³)

With fan operating at full speed, the flywheel power is 301 kW (403 hp) and maximum torque is 2 010 Nm (1 483 lb ft) which corresponds to DIN 70020.

***) Meets US (EPA) tier 3

***) with fan at normal speed.

The D12D engine is emission certified as a Family Engine with the following output data:
 Rated power at31,7 r/s (1 900 rpm)
 SAE J1995 Gross280 kW (375 hp)
 Max torque at 20 r/s (1 200 r/min)
 SAE J1995 Gross.....2100 Nm (1549 lb ft)

Engine brake: Exhaust retarder.

Fill capacities	
Crankcase	50 l (13.2 US gal)
Fuel tank	480 l (126.8 US gal)
Cooling system	117 l (30.9 US gal)
Transmission total	48,5 l (12.8 US gal)
Dropbox	10,5 l (2.8 US gal)
Axles, front/ rear	55 l (14.5 US gal)
Brake cooling tank	103 l 27.2 US gal)
Hydraulic tank	250 l (66.0 US gal)

Electrical System

All cables, sockets and pins are identified. Cables are enclosed in plastic conduits and secured to main frame. Halogen lights. Prewired for options. Connectors meet IP67 standard for water-proofing as necessary.

Voltage	24 V
Battery capacity	2x170 Ah
Alternator	2,24 kW (80 A)
Starter motor	7,2 kW (10 hp)

Drivetrain

	T450D
Torque converter	1,95:1
Transmission, Volvo	PT 1860
Dropbox	FL 1002
Axles, Volvo	AHW 71

Brake system

Fully hydraulic brakes with enclosed, forced oil-cooled multiple discs on all axles. Two circuits. Separate brake cooling for each axle. Complies with ISO 3450 and SAE J1473 at total machine weight.

Service brakes: Wet multiple disc brakes on all wheels.

Circuit division: One circuit for front axle and one for rear axle.

Parking brake: Spring-applied disc brake on the propeller shaft, designed to hold a loaded machine on a grade of up to 18%. When the parking brake is applied, the longitudinal differential is locked.

Compressor: Gear-driven by engine transmission.

Retarder: Hydraulic, infinitely variable, integrated in transmission.

Steering system

Cylinders: Two double-acting steering cylinders.

Supplementary steering: Complies with ISO 5010 at total machine weight.

Steering angle: 3,4 steering wheel turns lock-to-lock, ±45°

Cab

ROPS/FOPS approved: according to (ISO 3471, SAE J1040)/(ISO 3449, SAE J231) standards.

Sound level in cab: ISO 6396 72 dB (A)

Hydraulic system

Pumps: Three engine-driven variable displacement load-sensing, piston pumps driven by the flywheel PTO. One ground-dependent piston pump for secondary steering mounted on the dropbox.

Filter: Two fiberglass filters with magnetic core.

Pump capacity per pump:

Engine-dependent 143 l/min (37.8 US gpm)

Ground-dependent 202 l/min (53.4 US gpm)

at shaft speed 47,5 r/s (2 850 r/min)

Working pressure 25 MPa (3 626 psi)

Scraper Hydraulics

6-section Control valve:

Flow per section 100l/min (26.42 US gpm)

Pressure 21 MPa (3 046 psi)

EQUIPMENT

The Volvo T450D Standard Equipment

Safety

ROPS/ FOPS protected cab
Service platform for ease of service
Anti-slip material on hood and fenders
Hazard lights
Horn
Rearview mirrors
Retractable 3-inch safety belt
Secondary steering
Steering joint locking assembly
Windshield wipers front with interval function
Windshield washers front
25° rotating operators seat

Comfort

Tilt/telescopic steering wheel
Cab heater with filtered fresh air and defroster
Overhead console for radio
Sun visor
Tinted glass
Can holder /storage tray
Cigarette lighter
Ashtray
Space for lunch cooler
Storage box
Instructor seat with seat belt
Arm rest panel with "paddle levers"
Air-conditioning
Radio installation kit
Heated, air suspended, fully adjustable operator's seat
Radio with CD player

Service and maintenance

Electrical hood opening

Electrical system

80 A alternator
Battery disconnect switch
Extra 24 V socket for lunch cooler
Lights:

- Headlights
- Parking lights
- Direction indicators
- Rear lights
- Back-up lights
- Brake lights
- Cab lighting
- Instrument lighting

Operator information interface

Gauges:

- Speedometer
- Tachometer
- Brake pressure
- Fuel
- Transmission oil temperature

Pilot lights for all switches

Warning lights grouped and easy to read

Central warning (3 levels) for all vital functions

Central positioned information display:

- Automatic pre-start checks
- Operation information, easy-to-find menu
- Troubleshooting diagnostics
- Hour meter
- Clock
- Machine settings

Engine

Direct injected, electronically controlled
Turbocharged, intercooled
Remote oil drain plug
Remote oil filters, for ease of access
Preheater for easier cold starts

Drivetrain

Automatic transmission
Torque converter with automatic lock-up
Dropbox, single-stage
Hydraulic variable retarder
4x4 and 5 operator selectable drive modes
100% longitudinal differential lock
100% differential locks in all axles

Brakes

Two circuit, fully hydraulic brakes with enclosed, forced oil-cooled multiple discs on all axles.
Separate brake cooling for each axle.
Exhaust brake activation in brake pedal
Parking brake on prop shaft
Quickcoupler block with connection for scraper brake system.

Tires

29,5R25

Other

Air drier
Scraper hydraulics connected to the tractor with quickcouplers.
Scraper mode (cruise control)

The Volvo T450D Optional Equipment

(Standard on certain markets)

Safety

Fire-extinguisher and first aid kit

Service and maintenance

Tool kit with tire inflation unit

Engine

Extra air cleaner, heavy-duty
Electric engine heater (120V or 240V)
External emergency engine stop
Delayed engine stop
Fast fueling system
High engine idle speed

Electrical

Work lights, roof mounted
Rotating beacon, collapsible mount
Back-up alarm
Reverse lights, fender mounted
Anti-theft system (prevents engine start)
Headlights for left-hand traffic

Cab

Electrically heated rearview mirrors
Radio
Cable kit for cab heater (120V or 240V)
Window tint film
Head restraint
70" static seat belt

Tires

875/65R29

Other

Toolbox
Biodegradable hydraulic oil

The Volvo T450D Special Optional Equipment

Towing hitch for connection to Reynolds scraper
Towing hitch beam for local adaption to equipment





Volvo Construction Equipment is different. The company's products are designed, built and supported in a different way. That difference comes from our 175-year engineering heritage. A heritage of thinking first about the people who actually use the machines. About how to make them safer, more comfortable, more productive. About the environment we all share. The result of that thinking is a growing range of machines and a global support network dedicated to helping you do more. People around the world are proud to use Volvo. And we're proud of what makes Volvo different - **More care. Built in.**



Not all products are available in all markets. Under our policy of continuous improvement, we reserve the right to change specifications and design without prior notice. The illustrations do not necessarily show the standard version of the machine.

VOLVO

Volvo Construction Equipment
www.volvoce.com/na

Ref. No. 22 A 100 1929
Printed in USA 08/07 - 2,0
Volvo, Asheville

English
USA

VOLVO T450D SCRAPER HAULER ATTACHMENTS

ASHLAND I-180TS2



MORE CARE. BUILT IN.



ASHLAND I-180TS2 EJECTION STYLE SCRAPER

The I-180TS2 is designed for professional contractors who handle sandy loam to heavy black dirt or anything in between and require the highest production/lowest down time construction grade ejection scraper. The 56" apron opening eliminates the need for double or triple ejecting in heavy soils, making unloading quick and easy while maximizing production. Building on 54 years of manufacturing experience Ashland designed the I-180TS2 to meet the high demands of today's professional contractor.

Need to double your production?

Safe and easy tandem or triple hookup with heavy duty rear hitch.

Put your material where you want it!

The 56" apron opening, eliminates the need for double or triple ejecting in heavy soils making it a fast, easy unloading scraper that will maximize production.

Reduce downtime!

The rugged and simple design includes trunion-style lift cylinders and large trailing arms, creating less stress while operating or being pushed by a dozer.

Bigger is better!

With fast blade reaction you can maintain higher RPM's and get bigger loads faster.

The Ashland Advantage

When you buy an Ashland Scraper you are buying quality. Not just quality design and manufacturing, but quality service. At Volvo and Ashland, we realize that time is money. Together with our authorized dealers we know what it takes to keep your project moving in the right direction. From preventative maintenance to replacement parts we are available to help. If you have any service concerns, please contact your Volvo dealer.



MOVE MORE FOR LESS



Specifications

	English	Metric
Capacity Heaped	18 cu yd	13.8 cu m
Capacity Struck	14.5 cu yd	11.1 cu m
Width of Cut	126 in	320 cm
Apron Clearance	56 in	142 cm
Depth of Cut	8 in	20.3 cm
Depth of Spread	0-18 in	0-46 cm
Pushoff Cylinder (2) std.	4 in x 60 in	10 cm x 152.4 cm
Apron Cylinder (2) std.	5 in x 13 in Trunion	12.7 cm x 33 cm
Lift Cylinders (2) std.	5.5 in x 20 in Trunion	14 cm x 50.8 cm
Tire Size, Rear	29.5 x 25 28-ply OTR	
Weight Standard	24,720 lbs	11,213 kg
Max. Gross Vehicle Weight	80,000 lbs	36,290 kg

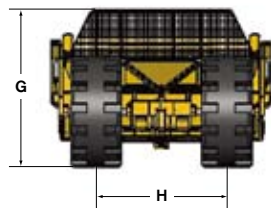

Dimensions

	English	Metric
A	142.125 in	361 cm
B	117.3 in	298 cm
C	20 in	50 cm
D	18 in	45 cm
E	17 in	43 cm
F	22 in	55 cm
G	101 in	257 cm
H	84.25 in	214 cm
J	368.5 in	963 cm

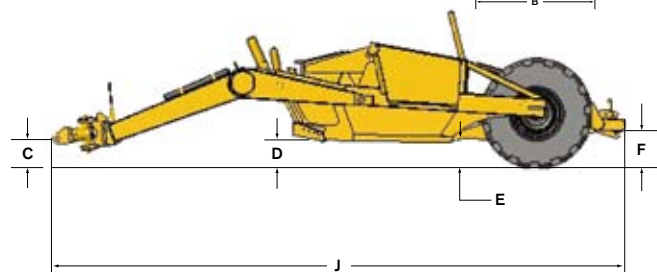

Options:

- Serrated Center Blade
- Hydraulic Package and Three Scraper Train.



Volvo Construction Equipment is different. The company's products are designed, built and supported in a different way. That difference comes from our 170-year engineering heritage. A heritage of thinking first about the people who actually use the machines. About how to make them safer, more comfortable, more productive. About the environment we all share. The result of that thinking is a growing range of machines and a global support network dedicated to helping you do more. People around the world are proud to use Volvo. And we're proud of what makes Volvo different - **More care. Built in.**



Not all products are available in all markets. Under our policy of continuous improvement, we reserve the right to change specifications and design without prior notice. The illustrations do not necessarily show the standard version of the machine.

VOLVO

Volvo Construction Equipment
www.volvoce.com/na

Ref. No. 22 1 000 9015
Printed in USA 11/07 - 1,5
Volvo, Asheville

English
USA