

B25D 6x6 ARTICULATED DUMP TRUCK Mk VII



Blu@dvantage™

- Gross Power: 210 kw (282 hp)
- Gross Torque: 1 120 Nm (826 lbft)
- Rated Payload: 23 200 kg (51,147 lbs)

BELL

B25D 6x6 **ARTICULATED DUMP TRUCK** MKVII

ENGINE

Mercedes Benz inline 6 cylinder, turbocharged, intercooled, low emission diesel engine

Gross power 210 kW (282 hp) @ 2,200 rpm
 Net Power 203 kW (272 hp) @ 2,200 rpm
 Torque 1,120 Nm (826 lbf) @ 1,200 -1,600 rpm

Displacement 7.2 litres (439 cu.in)
 Fuel tank capacity 310 l (85 US gal)
 Auxiliary Brake Exhaust brake
 Engine Valve Brake (EVB)

AdBlue Tank Capacity 31 l (8.2 US gal)
 Certification OM 926 LA meets Europe (EU) stage 3b emissions regulations

TRANSMISSION

Fully automatic ZF planetary transmission

Layout Engine mounted
 Gear Layout Constant meshing planetary gears, clutch operated

Gears 6 Forward, 1 Reverse
 Clutch type Hydraulically operated multi-disc

Control type Electronic
 Torque Converter Hydrodynamic with lock-up in all gears

TRANSFER BOX

Remote mounted

Manufacturer Bell
 Model 13100
 Layout Three in-line helical gears.
 Output Differential 67/33 torque proportioning, Pneumatically lockable on the move.

AXLES

High strength steel fabricated with spiral bevel type gears on the limited slip locking differential and heavy duty outboard planetary gears.

Model Bell 15T

BRAKING SYSTEM

SERVICE BRAKE Dual circuit, full hydraulic actuation caliper brakes on all wheels

Maximum brake force 164 kN (36,900 lbf)
PARK & EMERGENCY Spring applied, air released driveline mounted disc.

Maximum brake force 396 kN (89,000 lbf)



AUXILIARY BRAKE

Automatic exhaust brake and Engine Valve Brake (EVB)
 Variable Adjustable Hydraulic retarder in transmission

Maximum retardation 442 kW (593 hp)

WHEELS

Earthmover 23.5R25

FRONT SUSPENSION

Semi-independent, quad rubber mounted leading arm linkages supported by nitrogen and oil filled struts.

REAR SUSPENSION

Pivoting walking beams, distributing equal load through laminated rubber suspension blocks. Each axle is coupled to the chassis by four rubber-bushed links for ideal vertical movement.

HYDRAULIC SYSTEM

Variable displacement with load sensing system incorporating a ground driven emergency steering pump.

Flow 184 l/min (48.6 gal/min)
 Pressure 25 Mpa (3,915 psi)
 Filter 5 microns

Flow Pressure Filter

STEERING SYSTEM

Hydrostatically actuated, low effort, fast acting. Two double-acting steering cylinders

Lock to lock turns 4.1
 Steering Angle 45°

DUMPING SYSTEM

Two double-acting, single stage, dump cylinders

Raise Time 12 s
 Lowering Time 6 s
 Tipping Angle 70°

PNEUMATIC SYSTEM

Air drier with heater and integral unloader valve, serving park brake and auxiliary functions

System Pressure 810 kPa (117 psi)

ELECTRICAL SYSTEM

Voltage 24 V
 Battery Type Two maintenance free permanently sealed

Battery Capacity 2 X 105 Ah
 Alternator Rating 28 V 80 A

VEHICLE SPEEDS

1st	8 km/h
2nd	13 km/h
3rd	22 km/h
4th	31 km/h
5th	44 km/h
6th	53 km/h
R	8 km/h



B25D 6x6 ARTICULATED DUMPTRUCK MKVII

LOAD CAPACITY & GROUND PRESSURE

WEIGHTS		GROUND PRESSURE		LOAD CAPACITY		
UNLADEN	kg	LADEN (No sinkage)	kPa	BODY	m ³	cu.yd
Front	9,620	Front	246	Struck Capacity	11	14,4
Middle	4,420	Middle	287	SAE 2:1 Capacity	14	18,3
Rear	4,360	Rear	287	SAE 1:1 Capacity	18	23,5
Total	18,400			SAE 2:1 Capacity		
LADEN		LADEN (With sinkage)		with Autogate	14,5	19
Front	12,860	Front	133			
Middle	14,400	Middle	146	Rated Payload	23 200kg (51,147 lbs)	
Rear	14,340	Rear	146			
Total	41,600					

GRADEABILITY/RIMPULL

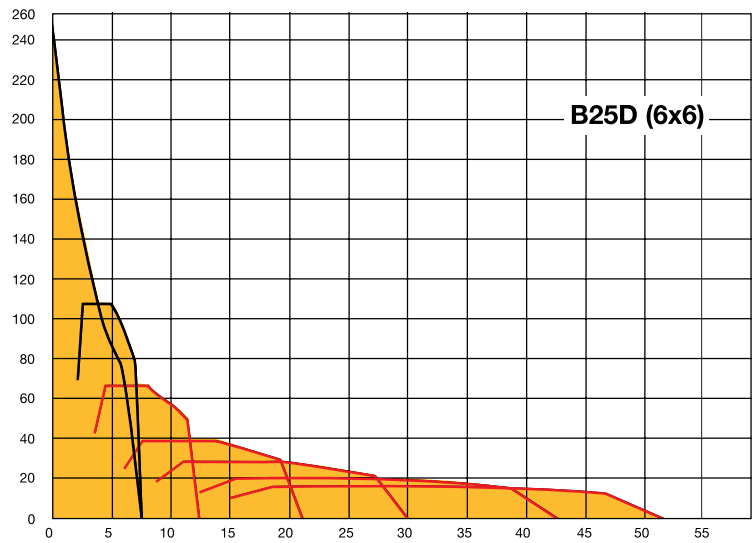
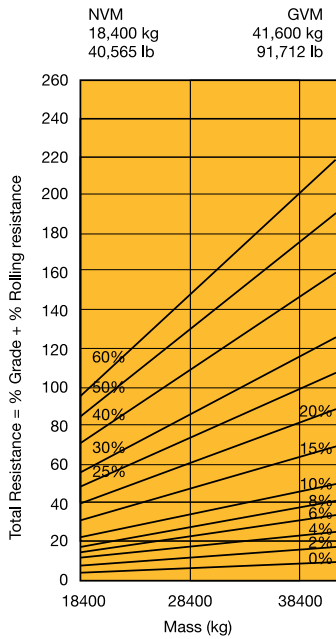

RETARDATION

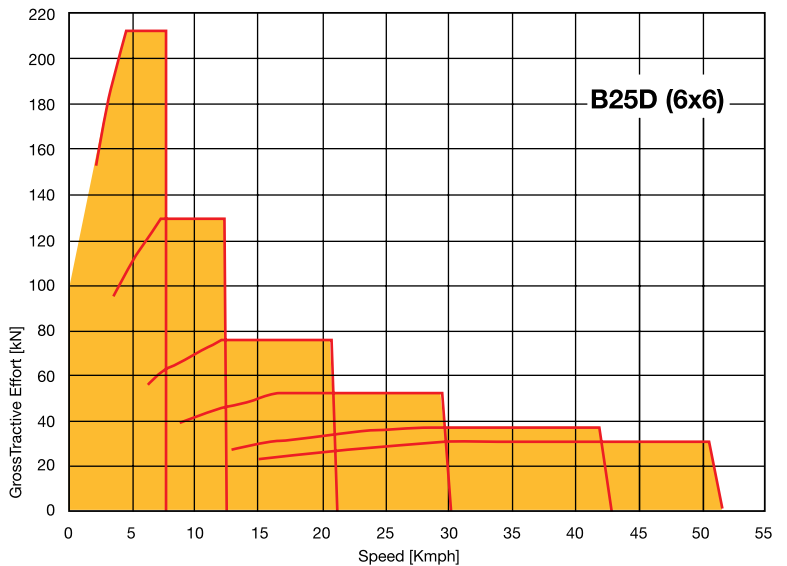
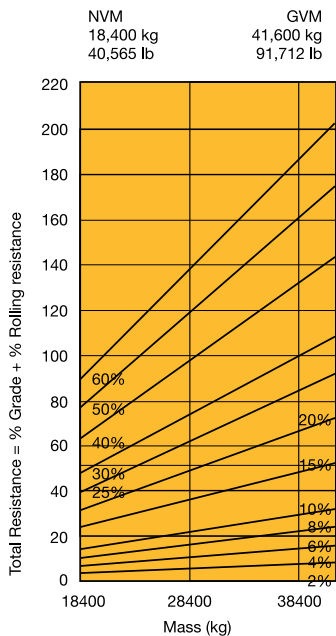

B25D 6x6 ARTICULATED DUMP TRUCK Mk VII

DIMENSIONS

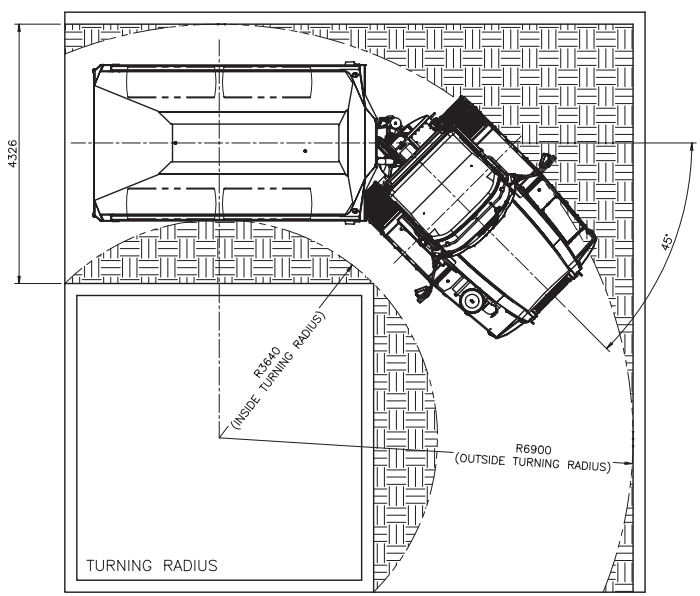
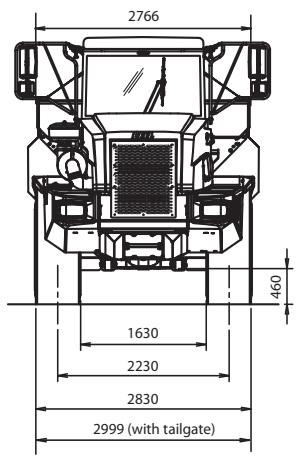
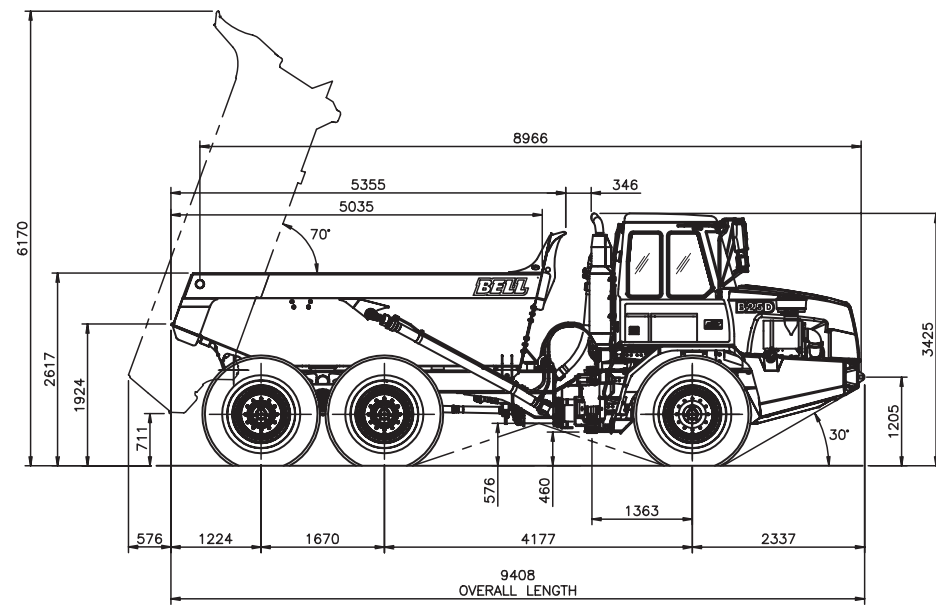

B25D 6x6 ARTICULATED DUMP TRUCK MKVII

AVAILABLE EQUIPMENT*

Cab

- ROPS/FOPS certification
- Protective rear window guard
- Tilt cab for service access
- Gas strut supported door
- Tinted safety glass
- Sliding windows
- Rear view mirrors- regular and wide angle
- Electrically adjustable rearview mirrors - one per side
- Sun visor
- Wiper/washer with intermittent control
- Tilt and telescoping steering wheel
- Adjustable, air suspension seat with retractable seat belt
- Fold-away trainer seat with retractable seat belt
- HVAC climate control system with filtered and ducted air
- Rotating beacon
- 12 V power outlet/12 V cigarette lighter
- Ash tray
- Drinks holder
- Cooled/heated lunch box
- I-Tip programmable bin tip
- Sound insulated to 76 dB(A) to ISO 6396
- Radio/CD/Tape
- Memory Module
- Air horn

MDU Features

- Operator / Site selected speed control
- Tipping counter
- Trip timer
- Trip distance
- On Board Weigh System (OBW)
- Transmission gear selection
- Fuel Consumption
- Diagnostics
- Intermittent wiper timing control
- Speedo calibration for alternative tyre sizes
- Metric /Imperial unit selection
- Warning lights with audible buzzer

Gauges

- Engine coolant temperature
- Engine oil pressure
- Transmission oil temperature
- Fuel
- Tachometer
- Battery voltage
- Hourmeter
- Odometer
- System air pressure

Vehicle

- Ground driven emergency steering
- Bin safety prop
- Articulation lock
- Integral transmission output retarder with 6 settings

Other

- (Factory or field installed)
- Groeneveld auto greasing system
 - Retractable sun visor
 - Exhaust body heating
 - Autogate
 - Body liners
 - Fleetmatic Satellite Monitoring System
 - Driver ID and immobiliser
 - Forward working lights
 - Artic reverse light
 - Fuel heater
 - External windshield visor
 - Headlight protection grills
 - Rear window wiper
 - Antenna mounting bracket
 - System for reverse camera
 - Wiggins quick fuelling system
 - Tyre pressure monitoring

*standard specification for machines may vary according to region



B25D 6x6 ARTICULATED DUMP TRUCK Mk VII

- The exclusive on-board weighing option presents the operator with real time information on the payload while the machine is being loaded. A 'limp home' mode can also be activated if the machine is significantly over-loaded.



- The park brake automatically applies when neutral is selected and it is not possible to engage neutral at speed. Torque dependent park brake release (hill assist) ensures no roll back on slopes.



- The incorporation of a Pitch and Roll sensor in the vehicle allows the bin to not be operated if the truck is in an unsafe position.



- Full hand-rails kit can be installed to provide even more safety when performing engine checks.



- Keyless start, driver identity, and access codes ensures no unauthorized operation of your equipment.



- Both operator or site selectable maximum speed control allows the vehicle to automatically de-accelerate and apply the retarder to prevent onsite speeding.



- Reverse cameras are available for factory or on site fitment ensuring full view when reversing.



- Optional Tyre pressure - monitoring System ensures that the operator has real time information on all tyres pressure and temperature conditions.

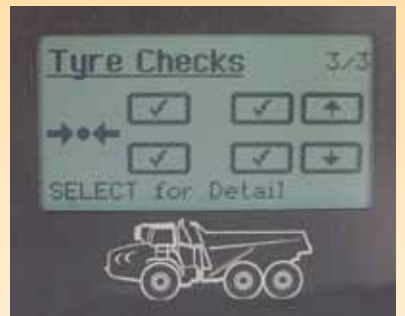

- The best in class retarder and engine braking automatically applies when the operator lifts his foot off the accelerator. Retarder aggressiveness can be simply adjusted on the sealed switch module ensuring maximum descent control for all conditions.

- All trucks can be set up to automatically sound the horn when starting or switching between forward and reverse.

BELL INTERNATIONAL: Tel: +27 (0) 35-907 9431

 Tel: +33 (0) 5 55 89 23 56

 Tel: +49 (0) 6631 / 91 13 - 0

 Tel: +34 91 879 60 19

 Tel: +27 (0) 11-928-9700

 Tel: +44 (0) 1283 712862

 Tel: +7 495 647 20 90

E-mail: sales@bellequipment.com

• www.bellequipment.com

All dimensions are shown in millimetres, unless otherwise stated between brackets. Under our policy of continuous improvement, we reserve the right to change specifications and design without prior notice. Photographs featured in this brochure may include optional equipment.

Strong Reliable Machines
Strong Reliable Support

BELL