

# B35D 6x6

## ARTICULATED HAULER



- Gross Power: 295 kW
- Gross Torque: 2 000 Nm
- Gross Combined Mass: 94 000 kg

# **BELL**

# B35D<sup>6x6</sup> ARTICULATED HAULER

## STANDARD EQUIPMENT

### Body

- Jost 37C fifth wheel hitch
- Standard Bell dia 90 ball hitch fitted on rear plate
- Increased departure angle
- Trailer brake kit, integrated with EVB
- 2 x Fire extinguishers fitted to mudguard

## APPLICATIONS

- Rough terrain lowbed trailer hauler
- Jinker trailer
- Scraper tractor

## OPERATING WEIGHTS

Laden:	Front	18 350 kg
	Middle	21 195 kg
	Rear	21 185 kg
	Total	60 730 kg

Max load transfer 35 000 kg

## LINE DRAWINGS

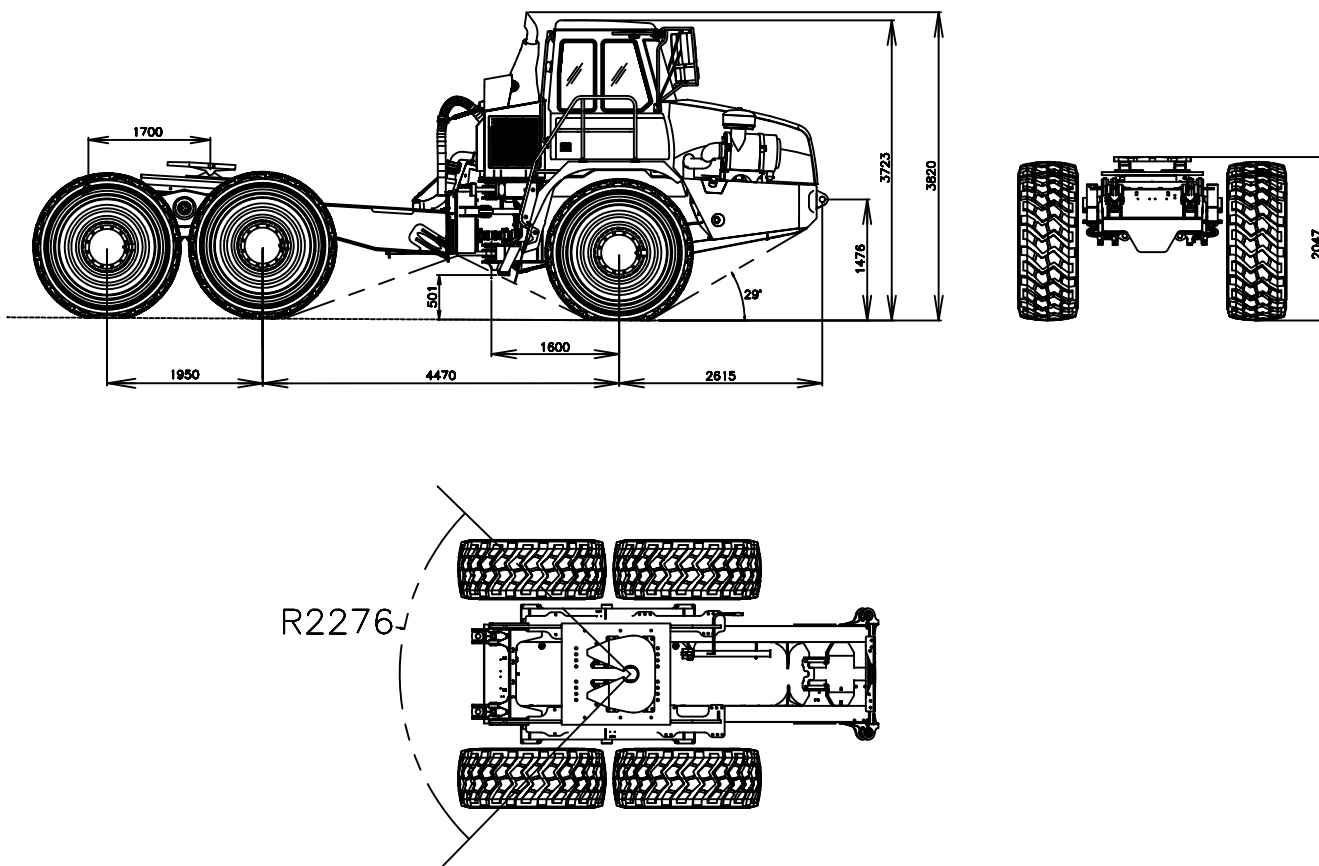

BELL INTERNATIONAL : Tel: +27 (0) 35 907 9431



Tel: +27 11 928 9700



Tel: +49 6631 911 30



Tel: +33 555 89 23 56



Tel: +34 918 796 019



Tel: +7 495 647 20 90



Tel: +44 1283 712 862

E-mail: sales@bellequipment.com • [www.bellequipment.com](http://www.bellequipment.com)

All dimensions are shown in millimetres, unless otherwise stated between brackets. Under our policy of continuous improvement, we reserve the right to change specifications and design without prior notice. Photographs featured in this brochure may include optional equipment.

**Strong Reliable Machines  
Strong Reliable Support**

**BELL**