

B50D 6x6

ARTICULATED HAULER



- Gross Power: 375 kW
- Gross Torque: 2 400 Nm
- Gross Combined Mass: 130 000 kg

BELL

B50D^{6x6} ARTICULATED HAULER

STANDARD EQUIPMENT

Body

- Jost 37C fifth wheel hitch
- Standard Bell dia 90 ball hitch fitted on rear plate
- Increased departure angle
- Trailer brake kit, integrated with EVB
- 2 x Fire extinguishers fitted to mudguard

APPLICATIONS

- Rough terrain lowbed trailer hauler
- Jinker trailer
- Scraper tractor

OPERATING WEIGHTS

Laden:	Front	23 440 kg
	Middle	28 225 kg
	Rear	28 255 kg
	Total	79 920 kg

Max load transfer 51 000 kg

LINE DRAWINGS

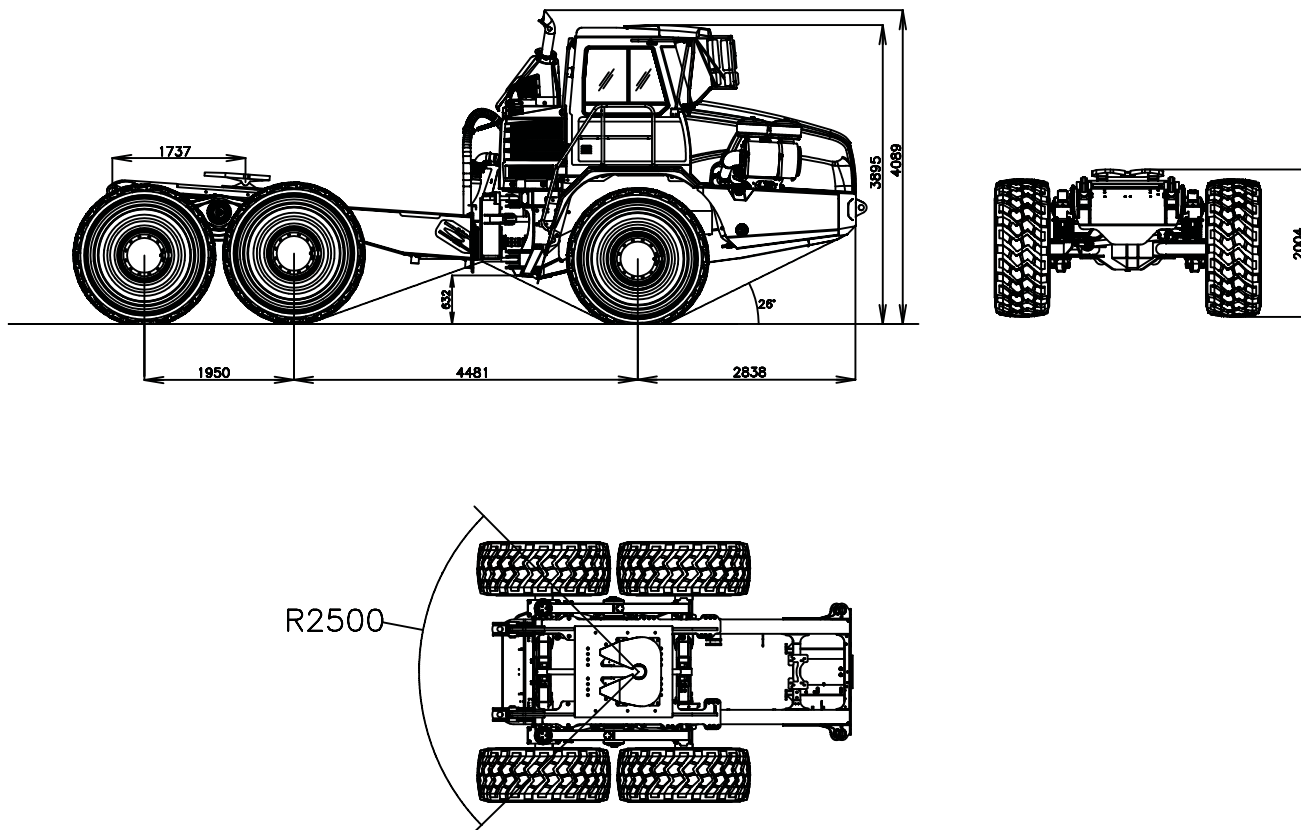

BELL INTERNATIONAL : Tel: +27 (0) 35 907 9431



Tel: +27 11 928 9700



Tel: +49 6631 911 30



Tel: +33 555 89 23 56



Tel: +34 918 796 019



Tel: +7 495 647 20 90



Tel: +44 1283 712 862

E-mail: sales@bellequipment.com • www.bellequipment.com

All dimensions are shown in millimetres, unless otherwise stated between brackets. Under our policy of continuous improvement, we reserve the right to change specifications and design without prior notice. Photographs featured in this brochure may include optional equipment.

**Strong Reliable Machines
Strong Reliable Support**

BELL