

### ENGINE

Model	Case Family IV 13 Liter, Tier III certified	
Type	4-stroke, variable geometry turbo and air to air cooled diesel	
Injection	Electronic	
Cylinders	In-line 6	
Bore/stroke	5.31 in x 5.9 in (135 x 150 mm)	
Displacement	787 in <sup>3</sup> (12.9 L)	
Aftercooler	Yes	
Horsepower per SAE J1995		
Gross	456 hp (340 kW) @ 2000 rpm	
Net	426 hp (318 kW) @ 2000 rpm	
Maximum torque @ 1000 rpm		
Net	1475 lb-ft (2000 N·m)	

### TRANSMISSION

Model	ZF 6WG310	
Type	Powershift	
Torque converter	Lock up all gears	
Ratio	1.84:1	
Gears	6 forward/3 reverse	
Forward travel – mph (km/h)		
1st	3.2 (5.2)	
2nd	5.0 (8.1)	
3rd	8.0 (12.9)	
4th	12.4 (19.9)	
5th	19.2 (30.9)	
6th	29.8 (48)	
Reverse travel – mph (km/h)		
1st	3.4 (5.5)	
2nd	8.5 (13.6)	
3rd	20.3 (32.6)	
Torque proportion – front/rear	33.3%/66.6%	
Dropbox	Gearbox integrated	
Gradeability	60% max. (27°)	

### BRAKES

Service	Multiple disks Oil cooled	
Parking – caliper (2)	protected disc (1) on drive shaft (pneumatic)	
Engine brake		
Transmission retarder		

### TRANSFER BOX

Mounting	Integral
Ranges	1
Front axle interlock	

### FRONT WHEEL ENDS

Make/model	ZF/RP 17
Type	Outboard planetary

### INTERMEDIATE AND REAR DRIVE AXLES

Make/model	ZF MT-D3105
Type	Outboard Planetary
Axle	Limited slip

### CHASSIS

Type	Front/rear box frame
Linkage	Universal joint

### STEERING/ARTICULATION

Frame connection	4 - taper roller
Articulation angle degrees	45°
Steering turns lock-lock	4.5
Secondary steering type	Ground drive

### SUSPENSION

Front type	Semi-independent arms
Front suspension	Nitrogen-oil
Rear type	2-Rocking beams
Rear suspension	Rods

### LOAD BODY

Construction	Ribless
Body tipping angle	68°
Body tipping time to raise/lower - sec	11/13
Tip cylinders type	Multi stage
Power down	Yes, 1st stage
Loadover height – ft/in (mm)	10 ft 2 in (3110)

### PAYLOAD

Payload – lbs (kg)	79,366 (36 000)
Capacity, struck	22.2 yd <sup>3</sup> (17 m <sup>3</sup> )
Capacity, heaped SAE 2:1	28.8 yd <sup>3</sup> (22 m <sup>3</sup> )

### DIMENSIONS

Overall length	35 ft 4 in (10 780 mm)
Overall tire width	10 ft 11 in (3340 mm)
Overall height	12 ft 7 in (3840 mm)
Approach angle	22.5°
Turning radius	
Outside	28 ft 7 in (8718 mm)
Inside	15 ft 2 in (4641 mm)

### CAPACITIES

Fuel tank – gal (l)	119 (440)
Hydraulic reservoir – gal (l)	79.3 (300)
Engine oil – gal (l)	9.2 (35)
Transmission – gal (l)	9.4 (35.5)
Front wheel ends – gal (l) (ea)	2.4 (9)
Drive axles	
Intermediate – gal (l)	9.0 (34)
Rear – gal (l)	8.7 (33)

### TIRES

Rim	5 section
Rim size	25 x 22
Standard tire	Tubeless 29.5 x R25

### WEIGHT

Weight	63,934 lb (29 000 kg)
Front:	31,614 lb (14 340 kg)
Rear (ea):	16,160 lb (7330 kg)
Total laden weight	143,300 lbs. (65 000 kg)

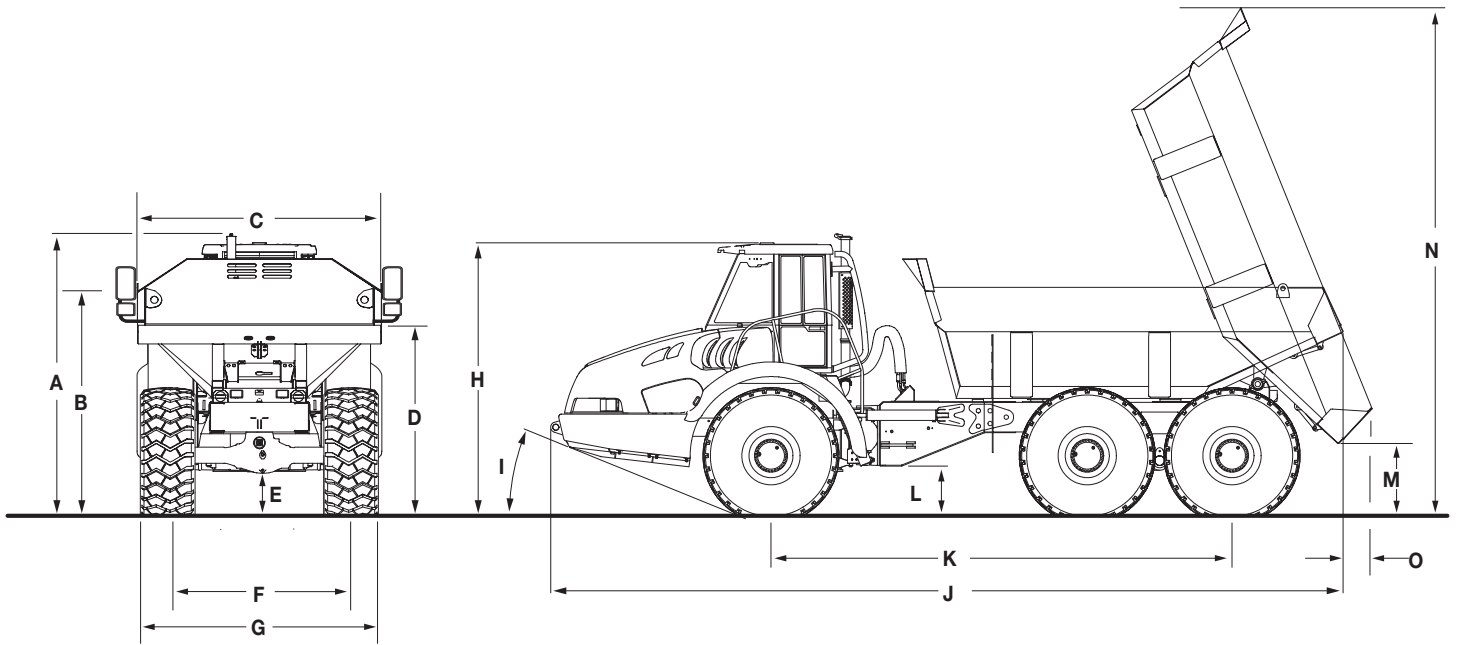

## DIMENSIONS

<b>A.</b>	Overall height – top of muffler	151 in (3.84 m)
<b>B.</b>	Height to side of load body	122 in (3.11 m)
<b>C.</b>	Load body width	131 in (3.34 m)
<b>D.</b>	Height to load bed end	103 in (2.61 m)
<b>E.</b>	Ground clearance – rear differential	23 in (0.58 m)
<b>F.</b>	Tread width – center to center	102 in (2.60 m)
<b>G.</b>	Overall width	131 in (3.34 m)
<b>H.</b>	Height to top of cab	146 in (3.72 m)
<b>I.</b>	Approach angle	22°
<b>J.</b>	Overall length	424 in (10.78 m)
<b>K.</b>	Wheelbase	246 in (6.27 m)
<b>L.</b>	Ground clearance @ articulation point	27 in (0.68 m)
<b>M.</b>	Dump clearance	39 in (0.98 m)
<b>N.</b>	Maximum height – dumping position	272 in (6.91 m)
<b>O.</b>	Rear dumping clearance	27 in (0.68 m)

---

**STANDARD EQUIPMENT**

---

**OPERATOR'S ENVIRONMENT**

ROPS (SAE J1040-ISO 3471)/  
FOPS (SAE J7231-ISO 3449) cab  
EPA off-road certified  
Heater/defroster/pressurizer  
Air conditioner  
Windshield wiper and washer, front and side  
Rear window protection grille  
Outside rear view mirrors  
Adjustable steering column  
Air suspension driver's seat  
3 inch wide retractable seat belt  
Training seat  
Radio ready  
Windshield sun shade  
Cup holder  
24V to 12V converter

---

**INSTRUMENTATION**

Hourmeter  
Tachometer (rpm)  
Speedometer (mph and km/h)  
Fuel level  
Engine coolant temperature  
Engine oil pressure  
Transmission oil pressure  
Transmission visual display unit

---

---

**OPTIONAL EQUIPMENT**

---

**BODY**

No body or hoist cylinders  
Rock body  
Body extensions  
Rear tailgate - mechanical  
Body heating kit

---

---

**INDICATOR LIGHTS**

Alternator charging  
Turn signal  
Service brake pressure  
Parking brake engaged  
Front axle interlock  
Dump body raised  
Warning lights test button

---

**SWITCHES**

Two speed front wiper  
Front wiper washer  
Side wiper washer  
Interior lights  
Horn  
24 volt cigarette lighter w/ashtray  
Hazard warning  
Reverse alarm  
Hi-beam lights  
Turn signal

---

**TRANSMISSION**

Hydraulic retarder

---

---

**TIRES**

Machine available equipped with four tires

---

---

**ENGINE**

Tier III certified  
Engine brake  
Electronic fuel injection  
Air cleaner – pre-cleaner

---

**ELECTRICAL**

24-volt system  
170 amp hour batteries (2) – 1200 CCA  
90 amp alternator  
Head light, stop light, reverse light  
Front and rear turn signals/flashers  
12-volt wiring for radio and CB  
Electrically operating tilt up hood

---

**HYDRAULICS**

Flow amplified  
Hydraulic diagnostic quick couplers

---

**EMERGENCY STEERING SYSTEM**

Ground driven steering pump (1)

---

**MISCELLANEOUS**

Auto Lube System  
Cold start aid – Grid heater  
Tool box

---

---

**OPERATOR'S ENVIRONMENT**

Rear view camera & monitor  
Rotating beacon

---

**MISCELLANEOUS**

Ground line start up  
Auto warm up with retarder  
Cab mounted work lights  
Engine block heater

---

**This page intentionally left blank.**

NOTE: All specifications are stated in accordance with SAE Standards or Recommended Practices, where applicable.

NOTE: All engines meet current EPA emissions requirements.

IMPORTANT: Case Construction Equipment Inc. reserves the right to change these specifications without notice and without incurring any obligation relating to such change. Case Construction Equipment Inc. does not warrant the safety or reliability of attachments from other manufacturers.

Case is a registered trademark of CNH America LLC. Any trademarks referred to herein, in association with goods and/or services of companies other than CNH America LLC, are the property of those respective companies.



[www.casece.com](http://www.casece.com)