

ENGINE

Model	Case/FPT 6.7 L, Tier 3 certified Compliant with EPA regulations effective January 2011 Electronic control
Type	4-stroke, turbocharged and air to air after cooled
Cylinders	6, in-line
Bore/Stroke	4.09 in x 5.17 in (104 mm x 132 mm)
Displacement	409 in ³ (6.7 L)
Fuel injection	Common rail
Fuel	Diesel
Cooling	Liquid
Horsepower @ 2200 RPM – SAE J1995:	
Gross	220/234 hp (164/175 kW)
Net	205/219 hp (153/163 kW)
Maximum torque @ 1600 RPM: 682/726 ft·lbs (924/984 N·m)	

POWERTRAIN

Rear axle	Graziano, planetary
Differential	Hydraulic lock, operator controlled
Outboard brakes	Wet disc
Number of discs/brake	6
Brake surface area	2,686 in ² (17 191 cm ²)
Tandems:	
Type	Welded plate
Oscillation	20° each way
Front axle	High strength, welded steel
Oscillation	15.3° each direction
Wheel lean	20° left/right
Tires	14.0 x 24 12PR TL G2 Firestone
Rims	1-piece 9 in x 24 in (227 mm x 610 mm)
Transmission type: Direct drive countershaft powershift w/ electronic shift control and inching pedal	
Pump flow @ 2200 RPM	29.5 gpm (112 L/min)
Sump	Integral
Speeds	8 forward/4 reverse
Shifting	Single lever, bump style automatic electronic control
Diagnostics	On-board

POWERTRAIN (CONT.)

Speeds:

Forward:	mph (km/h)
1st	2.39 (3.86)
2nd	3.18 (5.47)
3rd	4.68 (7.56)
4th	6.58 (10.62)
5th	9.58 (15.45)
6th	13.47 (21.73)
7th	19.0 (30.64)
8th	26.7 (43.0)
Reverse:	mph (km/h)
1st	2.39 (3.86)
2nd	4.68 (7.56)
3rd	9.58 (15.45)
4th	19.0 (30.64)

ELECTRICAL

Voltage	24 Volts, negative ground
Alternator	90 amp
Batteries (2)	Low-maintenance 1010 CCA – 100 Ah (20 hr rate)
Lighting: Headlights (2); Turn signals, front/rear; Stop/tail (2); Rear mounted floods (2); Front mounted floods (2)	
Backup alarm	Standard

OPERATOR ENVIRONMENT

DATA NEEDED	XXXX.XX xx (XXX xx)
DATA NEEDED	XXXXXXXXXX
DATA NEEDED	XXXXXXXXXXXX

OPERATING WEIGHT

With 14 ft (4.27 m) moldboard, 20.5-25 tires, front counterweight, 175 lb (79 kg) operator and full fuel:	
	41,248 lb (18 710 kg)
Weight, front axle	13,337 lb (6050 kg)
Weight, rear axle	27,910 lb (12 660 kg)
Blade pressure	26,278 lb (11 919 kg)

HYDRAULICS

Type	Closed center, load sensing
Hydraulic pump: Load sensing piston pump, variable displacement, pressure and flow compensated	
Rated flow @ 2200 RPM	49 gpm (186 L/min)

HYDRAULICS (CONT.)

Control valve	9 section
Side shift and pitch	Hydraulic
Saddle	5 positions
Diagnostic quick couplers	8

SERVICE CAPACITY

Engine	4.4 gal (17.5 L)
w/ filter change	4.7 gal (18.5 L)
Fuel	90 gal (341 L)
Transmission	5.8 gal (22 L)
w/ filter change	7.5 gal (28.5 L)
Radiator	10.5 gal (40 L)
Hydraulic reservoir	25 gal (94.6 L)
Hydraulic system	47.5 gal (180 L)
Circle gearbox	0.75 gal (2.8 L)
Rear axle center	10.5 gal (40 L)
Total axle	10.5 gal (40 L)
Tandem case, each	18.4 gal (69 L)

OTHER SPECIFICATIONS

Steering:

Type	Hydrostatic power steering
Turns (lock-to-lock)	4.75
Pump capacity @ 2200 engine RPM: 11.1 gpm (41.8 L/min)	
Relief pressure	2200 psi (151 bar) Integral with priority valve

Cylinder (2): 2.0 in bore x 11.85 in stroke x 1.0 in rod dia. (50.8 mm x 301.0 mm x 25.4 mm)	
Supplemental steering	Integral (Not applicable when equipped with 20.5 x 25 tires)

Articulation:

Type	Hydraulic actuated (with lock valve)
Range	25° left/right
Controls	Hydraulic

MAINFRAME

Type	All welded box
Front section:	
Size	10.0 in x 11.73 in (254 mm x 298 mm)
Weight	124.7 lbs-ft (172.8 kg/m)
Rear section:	
Size	4.75 in x 11.75 in (121 mm x 299 mm)
Weight (each side)	76.8 lbs-ft (114.2 kg/m)

DRAWBAR

Type:	"A" frame welded construction with center mounted circle turn motor
Ball and circle	Shim adjustable

MOLDBOARD

Type	High-carbon steel
Shape	Involute curve
Length	14 ft 0 in (4267 mm)
Height	23.6 in (600 mm)
Thickness	0.875 in (22.2 mm)
End bits	2, interchangeable
Blade pitch positions:	
Normal pitch	47°
Minimum pitch	42°
Maximum pitch	87°
Blade shift:	
Right	27.0 in (686 mm)
Left	21.0 in (533 mm)
Max. bank cutting angle: (right and left)	
	90°
Ground penetration (max.)	28 in (711.2 mm)
Lift above ground (max.)	17.5 in (444.5 mm)

CIRCLE

Type	Welded construction
Diameter:	
Max. outside	69.0 in (1752.6 mm)
Vertical member	63.0 in (1600.2 mm)
Rotation	360°
Speed	1.2 RPM (7.2°/second)
Drive	
Type	Hydraulic motor
Displacement	Roller Geroter 15.26 in ³ /rev (0.25 L/rev)
Rated hydraulic flow	19.8 gpm (75 L/min)

ATTACHMENTS

SCARIFIER

Type	Front mounted
Width of cut	46 in (1168 mm)
Teeth	5 (11 optional)
Tooth spacing	9.0 in (229 mm)
Optional	4.5 in (114.3 mm)
Lift above ground	20.75 in (527 mm)
Max. penetration	12.5 in (318 mm)
Weight	1,256 lb (570 kg) (includes front attachment group)

PUSH BLOCK

Type	Front mounted
Weight	1,084 lb (492 kg)

REAR RIPPER

Type	Parallel
Ripper teeth	3 (5 optional)
Scarifier teeth	5 (9 optional)
Width of cut	86.4 in (2195 mm)
Lift above ground:	
Ripper teeth	20.38 in (518 mm)
Scarifier teeth	27.67 in (703 mm)
Max. penetration:	
Ripper teeth	17.22 in (437 mm)
Scarifier teeth	9.43 in (252 mm)
Weight	1,874 lb (850 kg)

DOZER BLADE

Type	Front mounted
Width	109 in (2762 mm)
Height	37.5 in (953 mm)
Lift above ground	24.5 in (622 mm)
Penetration	6.5 in (165 mm)
Weight	2,568 lb (1165 kg) (includes front attachment group)

COUNTERWEIGHT

Type	Front mounted
Weight	1,084 lb (492 kg)

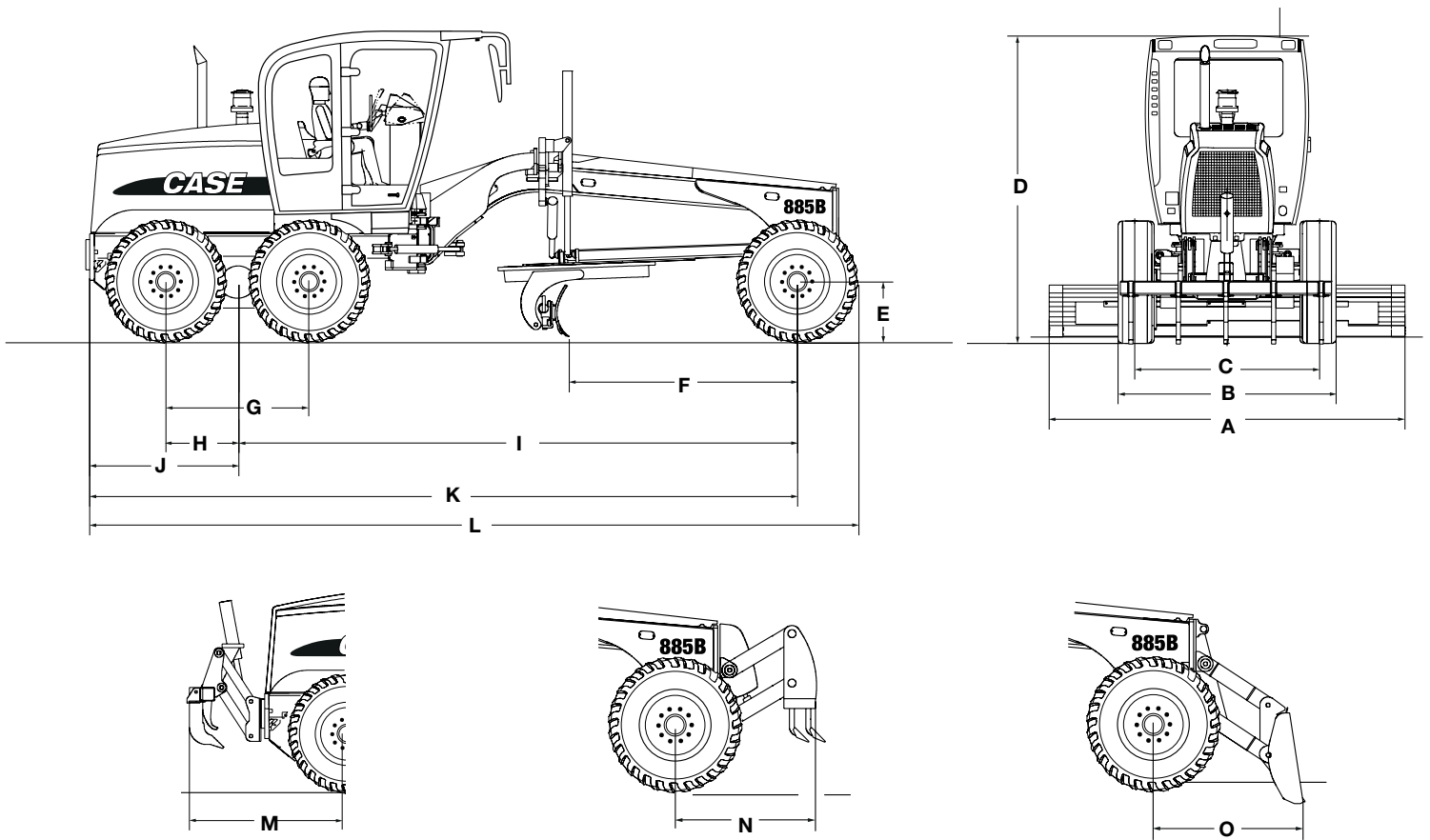

Line drawings are for illustrative purpose only and may not be exact representation of unit.

DIMENSIONS

	885B AWD
A. Blade width	14 ft 0 in (4267 mm)
B. Distance between outside edges of tires	8 ft 8 in (2650 mm)
C. Wheel tread	7 ft 1 in (2174 mm)
D. Height to top of cab	10 ft 11 in (3340 mm)
D. Height to top of cab – low profile	10 ft 4 in (3150 mm)
E. Tire radius – when static	2 ft 0 in (610 mm)
F. Blade base	8 ft 5 in (2562 mm)
G. Distance between tandem axles	5 ft 4 in (1624 mm)
H. Distance between tandem center and wheel	2 ft 8 in (812 mm)
I. Wheelbase	20 ft 5 in (6219 mm)
J. Distance between tandem center and rear end of machine	5 ft 5 in (1650 mm)
K. Distance between front axle and rear end of machine	25 ft 10 in (7874 mm)
L. Overall length (without ripper or front attachment)	28 ft 0 in (8534 mm)
M. Distance between rear tires & rear ripper	6 ft 8 in (2040 mm)
N. Distance between front tires & front scarifier	5 ft 0 in (1524 mm)
O. Distance between front tires & front dozer blade	5 ft 5 in (1645 mm)
Outside tire turning radius	23 ft 11 in (7289 mm)
Ground clearance (rear axle)	14.1 in (359 mm)
Ground clearance (front axle)	22.8 in (580 mm)

All units equipped with 17.5 x 25-12 PR tires, ROPS cab with heater & A/C, std. battery, full fuel, 175 lb (79 kg) operator. Specifications per ISO 7134.

STANDARD EQUIPMENT

OPERATOR STATION

ROPS/FOPS cab (SAE J231, ISO 3449)
Adjustable operator's console
Adjustable cloth suspension seat
3 in (76 mm) retractable seat belt
Safety glass
Dome light
Inside rear view mirror
Outside rear view mirrors
Cup holder
Storage tray
12-volt outlet
Radio ready (12 Volt)
Electrical master switch, automatic
Heater/defroster/pressurizer
Air conditioner
Sound suppression
Cab doors – left/right
Steps – left/right
Steering wheel
Windshield wipers – front and rear
Windshield washer – front
Window defroster – rear
Sunshade

POWERTRAIN

Hydraulic differential lock

OPTIONAL EQUIPMENT

MOLDBOARDS

12 ft x 22 in (3658 x 559 mm), involute curve
13 ft x 23.6 in (3962 x 600 mm), involute curve
Extensions – 2 ft (610 mm)
Front Float Control
Lift cylinder/side shift accumulator
Lift cylinder accumulator
Moldboard corner reinforcement

OPERATOR STATION

High profile ROPS/FOPS cab
Front windows – openable
Lower front wiper/washers
Rear windshield washer
Air suspension seat
Radio, AM/FM with CD player

ENGINE

Case/FPT 6.7 L turbocharged diesel
Tier 3 certified
Temperature controlled cooling fan
Charge air cooler
Air intake grid heater
Common rail electronic fuel injection
Hydraulic-driven cooling fan
Auto idle

HYDRAULICS

Closed center, load sensing hydraulic system
Controls for all functions
9 section control valve
Hydraulic moldboard side shift and pitch
5-position saddle
14 ft x 23.6 in (4267 x 600 mm) moldboard
Moldboard Float Control
8 hydraulic diagnostic quick couplers

TIRES

14.0 x 24-12 PR

INSTRUMENTS

Analog displays/Gauges:
Fuel level; Engine coolant temperature;
Transmission oil temperature;
Hydraulic oil temperature.

INSTRUMENTS (CONT.)

Monitor functions:
Hour meter; Engine speed; Travel speed;
Current gear selection; FNR indication;
Clock; Trip computer; Fuel consumption;
Fuel level percentage; Oil pressure;
Coolant temperature; Engine oil temperature;
Transmission oil temperature; Hydraulic oil
temperature; Turbocharger air temperature;
Differential lock indicator; Gear selection
indicator; Engine diagnostics; Transmission
diagnostics; System voltage; Error reporting;
Warning prompts; Indicator warning lamps—
main warning, parking brake, low brake
pressure, high beams, turn signals,
hazard lights, low fuel.

ELECTRICAL

Heavy duty batteries (2) – 1010 CCA
Electronic Systems Monitor
Horn
Alternator – 90 amp
Backup alarm
Headlights
Turn signals (2) front
Tail lights (2) with turn signals, brake lights
Flood lights – cab mounted

TIRES

14.0 x 24-12 PR
14.0 x R24 XGLA
14.0 x R24 Snoplus
16.0 x 24-12 PR
17.5 x 25-12 PR
17.5 x 25-16 PR
17.5 x R25 XTLA
17.5 x R25 Snoplus

ELECTRICAL

Front mounted working lights (2)
Floodlights (2) at moldboard
Floodlights (2) at articulation
Snow plow lighting package

OTHER

Bidirectional engine cooling fan
Cold weather package
Fire extinguisher
Strobe light
Tool box (w/o tools)
Deluxe tool box (w/ tools)
Tire inflator kit
Spare wheel
Spare wheel support
Slow moving vehicle sign
Rear pull hook

ATTACHMENTS

Front pull hook
Front counterweight
Front dozer blade
Front scarifier
Front push plate
Front support and lift cylinder
Rear ripper



NOTE: All specifications are stated in accordance with SAE Standards or Recommended Practices, where applicable.

NOTE: All engines are compliant with current EPA emissions requirements.

IMPORTANT: Case Construction Equipment Inc. reserves the right to change these specifications without notice and without incurring any obligation relating to such change. Case Construction Equipment Inc. does not warrant the safety or reliability of attachments from other manufacturers.

Case is a registered trademark of CNH America LLC. Any trademarks referred to herein, in association with goods and/or services of companies other than CNH America LLC, are the property of those respective companies.

Form No. CCE201204885BAWD
Replaces Form No. CCE201104885B

Printed in U.S.A.
885B AWD • Page 4 of 4



All Case construction equipment is biodiesel ready.



www.casece.com

© 2012 CNH America LLC
All Rights Reserved