

966H

Wheel Loader



Engine

Engine Model	Cat® C11 ACERT™	
Gross Power – SAE J1995	213 kW	286 hp
Net Power – ISO 9249	195 kW	262 hp

- Caterpillar engine with ACERT™ Technology – EPA Tier III, EU Stage III Compliant

Buckets

Bucket Capacities	3.4-4.2 m ³	4.5-5.5 yd ³
-------------------	------------------------	-------------------------

Weights

Operating Weight	23 698 kg	52,254 lb
------------------	-----------	-----------

- For 4.25 m³ (5.5 yd³) general purpose bucket with BOCE

Operating Specifications

Static Tipping Load, Full Turn	15 474 kg	34,120 lb
--------------------------------	-----------	-----------

- For 4.25 m³ (5.5 yd³) general purpose bucket with BOCE

966H Wheel Loader

Cat® H-Series Wheel Loaders – The New Standard For Midsize Loaders

RELIABILITY

- Proven Components And Technology Equal Proven Reliability
- Diagnostic Systems Monitor Product Health To Ensure Reliability
- Unmatched Parts Availability And Dealer Support **pg. 4**

DURABILITY

- ACERT™ Technology Maintains Performance, Efficiency And Durability While Meeting Emissions Regulations
- Heavy Duty Components Stand Up To All Operating Conditions
- Strong, Solid Structures Built To Last **pg. 6**

PRODUCTIVITY

- Improved Cycle Times With Load-Sensing Hydraulic System
- Constant Net Horsepower Through The Operating Range
- Aggregate Autodig Automates The Loading Process **pg. 8**

SERVICEABILITY

- Service Centers For Convenient Maintenance
- Exceptional Access To Service Points
- Monitoring Systems And Dealer Support Reduce Unexpected Downtime **pg. 16**

Performance you can feel with the capability to work in the most demanding applications. Unmatched operator comfort and efficiency in a world class cab. Revolutionary electronics and hydraulics for low-effort operation. Increased productivity with lower owning and operating costs.



VERSATILITY

- Special Machine Arrangements For Specialized Applications
- Large Variety Of Cat® Work Tools
pg. 10

OPERATOR COMFORT

- Easy Entry And Exit
- Excellent Visibility
- Comfortable Environment With Controlled Vibration
- Choice Of Steering And Implement Control Systems **pg. 12**

OWNING AND OPERATING COSTS

- Proven Fuel Efficiency
- Superior Maintenance
- Electronic Systems Monitor Product Health And Performance
- Complete Dealer Support **pg. 14**



RELIABILITY

The Cat® 966H – Tested And Proven – Ready To Work

- Proven components and technology provide proven reliability
- Electronic systems monitor vital machine components
- Excellent uptime from the best dealer support network in the industry
- Unmatched genuine Cat parts availability

PROVEN RELIABILITY. The 966H features many of the components designed and proven in previous 966 models – all contribute to the reliability of the 966H:

- Frames
- Axles
- Planetary powershift transmission
- Free wheel stator torque converter
- Separated cooling system
- Cab



ACERT™ TECHNOLOGY. Since March 2003, ACERT Technology has been proving itself in on-highway trucks. More recently it has proven itself again in field tests of off-highway equipment.

This technology allows Cat engines to meet durability and reliability expectations without sacrificing fuel economy or performance.



CATERPILLAR DESIGNED COMPONENTS.

Components used to build Cat Wheel Loaders are designed and manufactured to Caterpillar quality standards to ensure maximum performance even in extreme operating conditions.

Engine electronic control modules and sensors are completely sealed against moisture and dust. Deutsche connectors and electrical wire braiding ensure that electrical connections resist corrosion and premature wear.

Hoses are engineered and manufactured for high resistance to abrasion, excellent flexibility and easy installation and replacement.

Caterpillar® couplings use o-ring face seals to provide positive sealing for durable leak-free connections.

Heavy duty components reduce the risk of leaks, corrosion and premature wear increasing uptime and helping to protect the environment.

MONITORING PROGRAMS. Monitoring product health is key to maintaining reliability of any equipment. Many programs are available on the 966H – both as standard and optional features – to help you track machine condition.

Caterpillar Monitoring System. The 966H is equipped with the Cat Monitoring System (CMS) that keeps watch over the health of your loader. CMS monitors critical engine system functions and will derate the engine to protect itself from damage if needed. Depending on which of the following six critical conditions arise, the CMS monitor or front panel will display warning lights and sound audible alarms.

- High coolant temperature
- High air inlet temperature
- Low engine oil pressure
- High fuel pressure
- Low fuel pressure
- Engine over-speed

Product Link. Product Link is a state-of-the-art satellite technology based product that provides two-way information flow between machine on-board systems and the Caterpillar network operations center. Multiple types of information can be collected and tracked – from machine location and service meter hours, to health and productivity information.

EquipmentManager. With a subscription to EquipmentManager through the Cat Dealer Storefront the information collected through Product Link can be transmitted to a computer. With fast, easy-to-access machine information, you can optimize asset utilization, reduce security risks, improve maintenance management and implement before-failure repair strategies. The result is more uptime, lower operating costs and a higher overall return on equipment investment.

S•O•SSM Services. Keep minor repairs from becoming major ones and avoid complete failures. By regularly taking samples from the ports provided, your Cat dealer tracks wear of components and parts, oil performance, and oil condition and uses that data to predict wear-related problems before they happen. Often a simple adjustment or replacement of a part, based on S•O•S reports, can keep a small problem from turning into a major repair – allowing your machine to be running when you need it, not waiting in the shop for service.



DEALER SUPPORT. The Caterpillar global network of independently-owned dealers is the best in the world at providing support to keep your loader up and running. Known for parts availability and technical expertise, Cat dealers are partners in your business.



Service Capabilities. Cat field service technicians have the experience and tools necessary to service your loader on site. Field service trucks are fully loaded with state-of-the-art tools and diagnostic equipment as well as specifications and schematics for every Cat machine. Technical experts at the dealership and at Caterpillar are available to provide assistance to field service technicians when needed.

When on-site repair isn't enough, Cat dealerships are fully-equipped to service your loader quickly.

PARTS AVAILABILITY. Caterpillar provides an unsurpassed level of personalized service for your wheel loader. With parts distribution centers throughout the world, most parts can be delivered in 24 hours.

REMANUFACTURED PARTS. Cat engines and major components are designed to be remanufactured and provide multiple life cycles. The Cat Reman program is more extensive than most rebuild programs. Components are actually remanufactured in the factory to original specifications with necessary product updates.

Strict reuse guidelines and unparalleled quality control ensure that reman products provide the reliability and durability that you expect from Caterpillar. Reman products are stocked in distribution centers around the world and are ready to install to minimize downtime, maintain productivity and profitability.

DURABILITY

Built Strong And Tough

- ACERT™ Technology maintains engine performance, efficiency and durability while reducing emissions
- Heavy duty components withstand all operating conditions
- Strong, solid structures built to last



EPA TIER III, EU STAGE III COMPLIANT

C11 ENGINE. ACERT Technology combines proven systems with innovative new technologies to precisely deliver fuel to the combustion chamber. It maintains engine performance, efficiency and durability while dramatically reducing emissions.

The Cat C11 with ACERT Technology is an 11.1 L displacement, 6-cylinder, electronically governed engine. Electronic fuel injection is provided through the well-proven Caterpillar mechanically actuated, electronically controlled unit injection (MEUI) system. A wastegate turbocharger, equipped with a titanium wheel for improved durability, combined with air-to-air aftercooling (ATAAC) provides consistent high horsepower with increased altitude capability.

Electronic Controller. The engine is governed by an electronic control module designated the A4:E4V2. The controller continually adjusts engine output based on load demand using a series of sensors located on the machine and engine.

Mechanically Actuated Electronic Unit Injectors (MEUI). The MEUI system has been at work in Cat engines across the product line with a proven track record of consistent, durable, reliable performance.

Engine Block and Pistons. The gray, cast iron engine block is made of the same material as the cylinder heads. Wall diameters are thicker than in previous designs while adjustments have been made to reduce sound levels and increase rigidity. One-piece all-steel pistons are housed within a wet, replaceable cast iron cylinder liner constructed of high-strength, heat-treated castings. Steel-forged connecting rods are larger in diameter and are connected to the crankshaft with two bolts.

Cylinder Head. The cylinder head is a one-piece design that incorporates cross-flow design to facilitate air movement. This allows the engine to breathe cooler, cleaner air with less effort.

RADIATOR. Brazed aluminum construction provides a stronger joint for maximum durability and resistance to leaks. The 6-fins-per-inch, square-wave core design decreases the chance of blockage and plugging.

POWERSHIFT TRANSMISSION. The 966H continues to use heavy-duty powershift transmission technology proven on previous models and currently used up through the largest wheel loader built by Caterpillar, the 994F.

The planetary powershift transmission features heavy-duty components to handle the toughest applications. Built-in electronic controls enhance productivity and durability.

Control Throttle Shifting. Control Throttle Shifting regulates engine speed during high-energy directional changes for smoother shifting and longer component life.

Electronic Clutch Pressure Control.

Electronic Clutch Pressure Control (ECPC) system modulates clutches individually to improve shift quality, component life and operator comfort. Adjustment is simplified with all solenoid valves externally mounted on top of the transmission housing.

AXLES. The 966H axles are designed by Caterpillar for durability in all operating conditions. The front axle is rigidly mounted to the frame to support the weight of the wheel loader and withstand internal torque loads as well as external forces encountered throughout operation.

The rear axle is designed to allow $\pm 13^\circ$ oscillation. All four wheels remain on the ground over uneven terrain providing excellent stability and traction.



Integrated Braking System. The Cat exclusive Integrated Braking System reduces axle oil temperatures and improves transmission neutralizer smoothness. IBS has a direct impact on durability of the axles and brakes especially in applications involving long distances and/or heavy braking.

STRUCTURES. The articulated frame design of the 966H features a durable box-section engine frame and rigid four-plate loader tower that is robotically welded. Robotic welding creates frame joints with deep plate penetration welds and excellent fusion for maximum strength and durability.

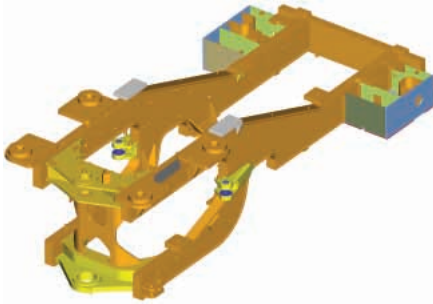

Engine End Frame (EEF). A full box-section engine end frame with hitch plates at the front end provides a strong, rigid structure that resists twisting and impact loads. The result is an extremely solid mounting platform for the engine, transmission, axle, ROPS and other accessories.

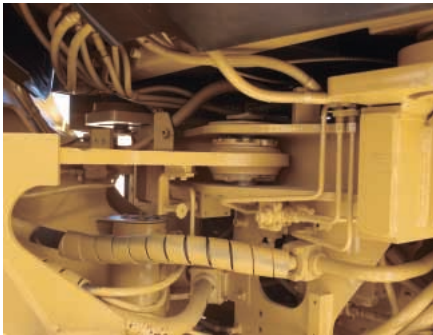

Spread Hitch. The distance between the upper and lower hitch plates is an important contributor to machine performance and component life. The Caterpillar spread hitch design provides excellent load distribution and bearing life. Both the upper and lower hitch pins pivot on double tapered roller bearings – improving durability by distributing both vertical and horizontal loads over a larger surface area. The wide opening also provides excellent service access.

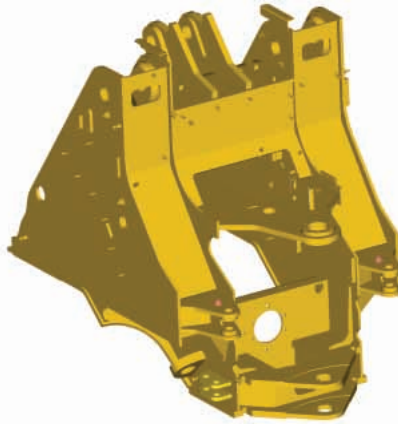

Non-Engine End Frame (NEEF).

The non-engine end frame provides a solid mounting base for the front axle, lift arms, lift cylinders and tilt cylinders. The fabricated, four-plate loader tower absorbs the forces associated with loading, twisting and penetration.



Counterweight. The one-piece counterweight is integrated into the 966H design and styling. This 2,517 lb (1142 kg) counterweight incorporates the rear lights into the top of the structure.

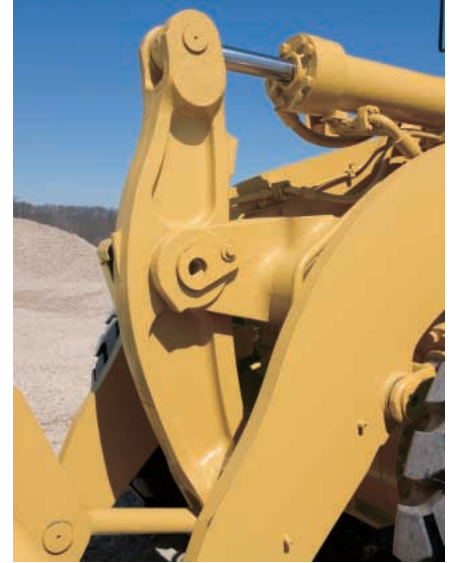

Linkage. The 966H linkage is a single-tilt Z-bar design. Z-bar linkage generates excellent breakout force and good rack back angle for better bucket loading and load retention.

Lift arms are solid steel, providing superior strength with an excellent front end viewing area. The proven design offers excellent dump clearance and reach for exceptional matching to both on- and off-highway trucks.

Rotary sensors, for the tilt lever and lift circuit allow the operator to electronically set detent positions from the cab. A guard covers the sensor to protect it from damage.

PRODUCTIVITY

Work Smart And Move More

- Hydraulics are easy to control with low effort
- Maximum fuel efficiency and flexibility in idle speeds
- Consistent horsepower regardless of conditions
- Standard and optional features that maximize productivity

LOAD SENSING HYDRAULICS. The 966H features a load sensing hydraulic system that automatically adjusts to operating conditions to provide only the hydraulic flow required by the implement for improved fuel efficiency.

With the new M3PC Priority Proportional Pressure Compensation Valve, implement control is improved over the previous system – raise/lower and rack back/dump can be operated simultaneously and fine modulation is repeatable for improved productivity.

Operators will notice enhanced ease of operation, more rimpull into the pile and a 20% increase in lift force.



Electrohydraulic Implement Controls. Electrohydraulic implement controls on the 966H provide the operator with in-cab programmable kickouts to prevent material spillage – improving productivity. The implement control console features an optional Forward/Neutral/Reverse switch allowing fast, easy directional changes to reduce cycle times.

CONSTANT NET HORSEPOWER.

On many competitive machines, gross horsepower is constant, meaning that net engine power available for actual work will vary based on demands made from parasitic sources, such as air conditioning or cooling fans.

The Cat C11 engine is electronically configured to provide constant net horsepower at full parasitic load enhancing productivity and improving fuel efficiency.

On-Demand Fan. With electronic control of the variable speed on-demand fan, temperature levels of the engine coolant, transmission oil, hydraulic oil and air inlet manifold are constantly monitored. This data is used to control and maintain fan speed at the level necessary to maintain normal system temperatures. Controlled fan speed improves fuel efficiency, lowers noise levels and reduces radiator plugging.

Separated Cooling System.

Many competitive loaders use cooling systems that pull air in from the sides, through the engine compartment and exhaust it out the rear of the machine. The 966H cooling system is isolated from the engine compartment by a non-metallic shield. The hydraulically driven, variable speed fan draws in clean air from the rear of the machine and exhausts it out the sides and top of the hood. The end results are optimal cooling efficiency, increased fuel efficiency, less radiator plugging and reduced operator sound levels.



PLANETARY POWERSHIFT

TRANSMISSION. The electronic planetary powershift transmission with automatic shift capability is designed and built by Caterpillar. The very responsive, full-power speed and directional changes provide excellent cycle times and productivity.

VARIABLE SHIFT CONTROL.

Match transmission shifting patterns to machine application requirements. Variable Shift Control (VSC) improves shift quality and fuel efficiency in certain applications by allowing the transmission to upshift at lower engine RPMs.



RIDE CONTROL. The optional Ride Control System improves ride, performance and load retention when traveling over rough terrain. Operators gain confidence moving at higher speeds in load and carry operations decreasing cycle times and increasing productivity.

PAYLOAD CONTROL SYSTEM. Scales, designed specifically for Cat machines allow on-the-go weighing of material in the bucket. Operators load trucks more accurately and efficiently. Loading trucks right the first time equates to quicker cycles for the operator and more productivity for your operation.

Payload Control is offered as a factory-installed option. Driver tickets and a variety of reports can be printed with the addition of the optional printer.

AUTOLUBE. The optional Caterpillar Autolube System provides precise, automatic lubrication of pins and bushings – during loader operation. Automatic lubrication reduces time spent on daily maintenance and downtime for unplanned repairs due to inadequate greasing – improving productivity.

AGGREGATE AUTODIG. Well-received by both experienced and novice operators, the optional Aggregate Autodig automates the loading process.

Aggregate Autodig provides smoother loading cycles, consistently full payloads and eliminates tire spin – all without touching the controls.



VERSATILITY

Built For Your Operation

- Special machine arrangements provided from the factory
- A variety of buckets and work tools for many applications

SPECIAL MACHINE ARRANGEMENTS.

When you have a specialized operation, you need a specialized wheel loader to be productive. The following machine arrangements are available for the 966H:

Aggregate Yard Loaders. The Yard Loader Value Package provides the ultimate in productivity and convenience. Options such as Autolube, Aggregate Autodig, Payload Control and Ride Control reduce operator fatigue and make your wheel loader the most productive yard loader available.



Forestry Applications. The Forest Machine Arrangement provides Ride Control, a heavy-duty tilt cylinder and an additional counterweight for use in forestry and logging applications.



Industrial Loader. Heavy duty guarding and special features designed specifically for industrial applications, such as waste and scrap handling, allow the 966H to withstand the harshest of conditions. Work tools designed specifically for these applications can be added to the machine.

Lift Arrangements. High lift arrangements are available for applications requiring additional dump clearance. Both 2-valve and 3-valve packages can be factory installed for conventional and Command Control machines.

WORK TOOLS AND QUICK COUPLERS.

A variety of buckets, work tools and couplers are available from the factory or from your Caterpillar dealer to customize the 966H for your operation.

Quick Couplers. Quick couplers provide unmatched versatility for wheel loaders. Buckets and work tools can be changed in seconds without leaving the cab for maximum productivity.



General Purpose Buckets.

General purpose buckets provide good all-around performance for stockpiling, rehandling, excavating and bank loading. A heavy duty general purpose bucket can be used for more aggressive applications.

Material Handling Buckets. The material handling bucket is a flat-floor bucket used for handling stockpiled materials such as aggregates or other easy-to-load materials requiring moderate breakout force.



Rock Buckets. Rock buckets are designed for face or bank loading in mining or quarry applications. The straight-edge rock bucket provides higher breakout force and increased dump clearance. The spade-edge rock bucket offers increased penetration in certain applications.

Coal Buckets. Coal buckets maximize productivity in loading and stockpiling coal and other materials of similar density.

Heavy Duty Quarry Buckets. The heavy duty quarry bucket is available for high-impact or high-abrasion quarry applications.



Waste Buckets. Waste buckets are designed for long life in the harsh world of refuse applications. This high-capacity bucket is well-suited for loading, sorting and other transfer station work.

Woodchip and Clean-Up Buckets. Woodchip and clean-up buckets are available for forestry and millyard applications.

Multi-Purpose Buckets. Multi-Purpose Buckets have a unique four-way action that can load, strip topsoil, bulldoze, clamp pipe or large chunks of concrete, clean up debris, and many other tasks.

Side Dump Buckets. Side Dump Buckets dump both to the front and to the side of the machine, an advantage when working in tight quarters, such as street work, tunnel construction and building levees.



Forks. Logging, millyard and pallet forks are available for forestry and material handling applications.

Loader Rakes. Loader Rakes are durable, high-capacity tools for land clearing and site clean up. Rakes are available with or without top clamps and in quick coupler and pin-on models.

Material Handling Arms. Material Handling Arms move pipe, concrete blocks, highway dividers and other construction materials quickly and precisely.

Ground Engaging Tools (GET).

Several GET options are available from Caterpillar for the 966H buckets. A cast corner adapter is incorporated into the design of the buckets that allows a tooth to be placed on the extreme corner for protection against base bucket wear.

Reversible bolt-on cutting edges (BOCE) and a bolt-on half-arrow cutting edge are also available for the 966H buckets.

The Cat K-Series™ tooth system features an easier-to-install tip and provides very secure tooth retention. No special tools are required for installation and removal.

OPERATOR COMFORT

Work Comfortably And Efficiently

- Comfortable operation
- Excellent visibility
- Easy entry and exit
- Controlled vibration
- Choice of steering systems

OPERATING ENVIRONMENT. The 966H maintains the distinction of offering the largest, most ergonomic cab in its class.



Seat. The Cat C-500 Series Comfort air suspension seat, standard in the 966H, is built strong and durable and is 6-way adjustable to accommodate all-sized operators. The cast one-piece back and seat pan prevent protrusions under the cushions. The seat features an automotive-style lumbar support for maximum comfort. The right hand armrest with integrated implement controls adjusts for comfortable, convenient operation. A heated seat option is available for additional comfort.

VISIBILITY. The 966H offers excellent visibility to both the front and rear of the machine. Distortion-free flat glass stretches to the floor of the cab for excellent visibility to the bucket. Wet-arm wipers on both front and back keep the windows clean in any condition. The cab roof has channels that direct rain off the corners of the cab keeping windows clear. An overhang on all sides protects the operator from glare.

Windshield Cleaning Package.

An optional windshield cleaning package provides additional steps and handrails to provide easy access for cleaning the front windows.

Rear Vision Camera. An optional rear vision camera is available to clearly monitor movement behind the wheel loader.



Lighting Packages. Optional lighting packages are available for roading or low-light applications. The optional High Intensity Discharge (HID) lights provide exceptional lighting for night work. A rotating beacon is available as a safety feature.

VIBRATION. Caterpillar understands that wheel loaders work in some of the harshest environments. By controlling normal machine vibrations, operator efficiency and productivity are improved. From the ground up, the Cat 966H is designed with many features, both standard and optional, that reduce vibration.

- The oscillating rear axle follows the contour of the ground while allowing the cab to stay steady.
- The cab is attached to the frame with iso-mounts designed to reduce shock loads from the ground.
- The articulation joint is equipped with two neutralizer valves that prevent frame-to-frame contact.

- Cylinder dampening slows the bucket as it reaches the limits of travel, preventing machine jarring.
- Ride Control is an option designed to reduce jolting and bouncing during load and carry operations. An accumulator acts as a shock absorber to reduce machine pitching and provide a smoother ride over rough terrain.
- Electronically controlled, automatic kickouts prevent the jerking and bouncing associated with abrupt cylinder stops.
- Air suspension seat-mounted implement controls reduce vertical vibrations that come up through the floor.



ENTRY AND EXIT. A ladder with self-cleaning steps keeps debris build-up to a minimum. The ladder is at a 5° forward incline for easy entry and exit.

Platforms are wide allowing ease of movement to the front or rear of the machine. The main cab door opens a full 180° and latches in place to allow safe navigation to the rear of the machine.

The right side door opens 10°, or completely for secondary exit simply by pulling a pin. A full-length ladder on the right side facilitates safe exit if needed.

STEERING OPTIONS. The 966H offers a choice of steering systems to provide flexibility for your application.

Conventional Steering. The conventional steering configuration offers a low-effort hand metering unit hydraulic steering system. Load sensing steering directs power through the steering system only when needed. When not steering, more engine power is available to generate rimpull, breakout force, lift force, and results in reduced fuel consumption. The steering column tilts for maximum operator comfort.



Command Control Steering. Command Control Steering is a load-sensing system that links the steering wheel and frame angle positions to provide the proper amount of steering control. The speed the machine turns is proportional to the steering wheel position. Less than 6 lb (26 N) steering effort is required by the operator, regardless of conditions. Full machine articulation is accomplished with a $\pm 70^\circ$ turn of the wheel – versus two to three 360° turns of a conventional steering wheel.



The Command Control Steering wheel contains the forward/neutral/reverse switch and the upshift/downshift button – allowing the left hand to remain on the steering wheel at all times. Implement controls are integrated into the right armrest so they move with the operator.

CONTROLS. The main control panel on the 966H is located high on the right ROPS post – keeping everything within reach of the operator while maintaining visibility to the ground. Keeping all switches and controls conveniently placed allows better efficiency and improved productivity all while minimizing operator fatigue.

AGGREGATE AUTODIG. The optional Aggregate Autodig System provides smoother loading cycles and consistently full payloads without touching the controls – reducing operator fatigue.

OWNING AND OPERATING COSTS

The 966H – Best Value For Your Operation

- More return for your wheel loader investment through proven Cat fuel efficiency
- Sight gauges, grouped maintenance points, easy engine access, ecology drains, maintenance-free batteries – all simplify daily maintenance
- Electronic monitoring systems track product health to avoid unscheduled costly repairs
- Unsurpassed parts availability reduces downtime
- Excellent resale value provided by genuine Cat quality, outstanding dealer service and unmatched dealer support programs
- Caterpillar Financial Services and Cat dealers understand your business



FUEL EFFICIENCY. Many manufacturers tout fuel consumption as one of the determining factors for machine acquisition, but fuel consumption is only part of the story. Productivity must also play a part in the decision. Even more importantly, how fuel consumption and productivity interact – fuel efficiency – should be considered.

966H Fuel Efficiency. Customer testing of the 966H is showing an improvement in fuel efficiency over the 966G Series II. This fuel savings is achieved through the use of the Caterpillar proportional-flow load sensing hydraulic system, Engine Idle Management System software, Variable Shift Control and ACERT Technology.

ACERT™ Technology Fuel Economy. Based on Caterpillar testing, the fuel economy of Cat engines with ACERT Technology is 3 to 5 percent better than current competing technologies. This fuel economy is directly related to the complete combustion of fuel due to the integration between the electronic control that monitors conditions, the air management system that controls air volume and the fuel injection system that delivers just the right amount of fuel as needed.

Free Wheel Stator Torque Converter (FWSTC). The free wheel stator torque converter improves power train efficiency in load and carry operations which contributes to the improved fuel efficiency of the 966H.



ENGINE IDLE MANAGEMENT SYSTEM. The Engine Idle Management System (EIMS) maximizes fuel efficiency and provides flexibility in managing idle speeds for specific application requirements. Four idle control speeds are available.

Hibernate Mode. Idle speed drops after a preset time to provide lower fuel consumption, reduced sound levels and lower emissions.

Work Mode. Adjust to working idle speeds according to customer preference and operating conditions.

Warm-Up Mode. Keep the engine at a consistent temperature in cold conditions.

Low Voltage Mode. Prevent battery drain due to high electrical loads from attachments and accessories.



MAINTENANCE. Proper maintenance of your wheel loader can help control expenses and lower your owning and operating costs. The 966H provides unmatched serviceability by offering:

- Hydraulic service center
- Electric service center
- Well-protected, easily visible sight gauges
- Ground level maintenance points
- Easy access to engine compartment
- Ecology drains for simple and clean fluid drainage
- Brake wear indicators for ease of inspection
- Maintenance-free batteries
- Extended oil and filter change intervals
- Airborne debris-resistant, swing-out grill provides more efficient airflow

MONITORING SYSTEMS. Monitoring product health simplifies maintenance planning and reduces costs.



Caterpillar Monitoring System.

The Caterpillar Monitoring System (CMS) tracks critical machine systems to alert the operator to potential need for service. Three levels of warning allow the operator to assess the situation more accurately.

Product Link. With Product Link owners can collect and track multiple types of information – from machine location and service meter hours, to health and productivity information.

EquipmentManager. With a subscription to EquipmentManager information from Product Link can be transmitted to a computer. Return on equipment investment is optimized through maintenance management and improved uptime.

Machine Security System.

Stolen equipment equates to lost production and increased costs. Eliminate machine theft and unauthorized usage with the Cat Machine Security System (MSS). MSS is integrated into the machine’s electronic system and can protect most brands of equipment by requiring a uniquely coded key to start the machine.

S•O•S Services. Managing component life and machine availability decreases downtime while improving your productivity and efficiency. S•O•S Services can help you do that. Regular fluid sampling is used to track what is going on inside the equipment. Wear-related problems are predictable and easily and quickly repairable. Maintenance can be done according to your schedule, resulting in increased uptime and flexibility in maintenance and repair before failure.



PARTS AVAILABILITY. Caterpillar provides an unsurpassed level of personalized service for your wheel loader. With parts distribution centers worldwide, most parts can be delivered in 24 hours. Easy access to parts reduces downtime.

RESALE VALUE. Owning quality equipment is a very important factor in maintaining resale value. Cat not only supplies quality equipment but also provides product and dealer support to maintain the reliability and durability of your machine.

Customer Support Agreements.

A Customer Support Agreement (CSA) is any arrangement between you and your Cat dealer that helps you lower your total cost per unit of production. CSAs are flexible, allowing them to be tailored to your business. They can range from simple Preventive Maintenance Kits to sophisticated Total Cost Performance Guarantees. Having a CSA with your Cat dealer allows you more time to do what you do best – run your business.

Caterpillar Equipment Training Solutions.

A thorough understanding of machine systems and a high level of skill in operation helps achieve maximum efficiency and improves return on investment. Caterpillar Equipment Training Solutions programs help provide operators with high levels of proficiency and confidence. Contact your Cat Dealer for more information on Caterpillar Equipment Training Solutions programs.

Caterpillar Financial Services

Corporation. Cat Financial understands your business, your industry and the challenges you face. That’s why they can provide payment plans to fit your unique needs – and to help you achieve your goals.

SERVICEABILITY

Easy To Maintain – Easy To Service

- Grouped service points and sight gauges for easy daily maintenance
- Convenient access to engine compartment for excellent serviceability
- Swing-out grill and cooling cores for easy cleaning
- Electronic systems to monitor product health



HYDRAULIC SERVICE CENTER.

Transmission oil and hydraulic filters are located in the Hydraulic Service Center, behind the hinged, right-side access ladder. The hydraulic oil tank can be drained from this location using the access port.

- Hydraulic filter change interval at 500 hours
- Transmission filter change interval at 1,000 hours



ELECTRIC SERVICE CENTER. Batteries, relay panel and an optional tool box are conveniently located below the left-side access platform. The engine shutdown switch is housed with the relay panel. A compartment integrated into the access platform contains the hood tilt actuation switch, master switch and jump-start receptacle.



GROUND LEVEL GREASE POINTS.

Grease fittings are grouped on the right side of the machine in two convenient locations – in a service compartment just below the right-side service platform, and a bank located just off the non-engine end frame. These locations facilitate easy lubrication of vital components located throughout the machine.

AUTOLUBE. Reduce time spent on daily maintenance and downtime for unplanned repairs due to inadequate greasing with the optional Caterpillar Automatic Lubrication System. Precise lubrication of pins and bushings at specific intervals improves component wear and reduces ground contamination from excessive greasing.

S•O•S SERVICES. Sampling valves on the 966H allow quick access to engine, transmission and hydraulic oils for S•O•S analysis. Oil change intervals and other services can be optimized according to your work schedule, reducing downtime and managing expenses.



REMOTE PRESSURE TAPS. Pressure taps for the steering and hydraulic systems, transmission (optional) and brakes are grouped behind an access panel just below the right-side service platform.

BRAKE WEAR INDICATORS. Axles are equipped with standard brake wear indicators, allowing a technician to easily determine when it is necessary to service the brakes.

SIGHT GAUGES. Well-protected, yet easily visible sight gauges for the transmission, hydraulic oil and radiator coolant allow easy daily checks while reducing the risk of contaminants entering the systems.



ENGINE COMPARTMENT ACCESS.

The non-metallic hood on the 966H has been redesigned and restyled from previous models. Side and top panels are stronger due to more robust reinforcement ribs – the change in contour also adds to rigidity of the hood.



A single mechanical lift cylinder with manual back-up opens the hood. The tilting hood provides excellent access to the engine compartment, and if necessary, the entire hood can be removed with the built-in lift points.



With the hood closed, quick checks of engine oil levels and the coolant sight gauge can be completed through the side service doors.

Panels located behind the tires lift up and can be removed for additional access. Roading fenders hinge from the rear and swing out allowing easier access to the engine compartment.

ECOLOGY DRAINS. Engine, transmission and hydraulic oils can be easily drained with standard-equipment ecology drains. An axle oil ecology drain is optional.

ELECTRIC PRIMING PUMP. An electric fuel priming pump located on the primary fuel filter base eliminates the need to pre-fill or manually prime filters after a change, eliminating engine contamination.



COOLING SYSTEM. Cooling system access for clean-out and maintenance is outstanding. The perforated and corrugated grill minimizes debris build-up and swings out for easy cleaning and access to the cooling cores.

The full-width air conditioning condenser and oil cooler cores swing out 45° to allow easy cleaning of the rear radiator face. Access panels on either side of the radiator support structure provide access to the front face of the radiator and ATAAC cores for easy cleaning.

CAB. The entire operator station can be removed in about 45 minutes and is easy to re-attach. Quick disconnects are used so no wires need to be cut and no refrigerant is lost.

Cab cleaning is made easy with channels on the cab floor and no threshold at the door – the floor can be swept or mopped out easily.

WINDSHIELD CLEANING PACKAGE.

An optional windshield cleaning package consists of two steps for the loader front frame, two additional handrails and a folding mirror. This package allows access to the entire front windshield for easy cleaning.

COMPLETE CUSTOMER SUPPORT.

Cat field service technicians have the experience and tools necessary to service your loader on site. Technical experts at the dealership and Caterpillar can provide additional assistance to field service technicians as needed.

When on-site repair isn't enough, Cat dealerships are fully equipped to service your loader quickly.

Engine

Engine Model	Cat® C11 ACERT™	
Gross Power – SAE J1995	213 kW	286 hp
Net Power – ISO 9249	195 kW	262 hp
Net Power – SAE J1349	193 kW	259 hp
Net Power – 80/1269/EEC	195 kW	262 hp
Peak Torque (Net) @ 1,400 rpm	1215 N•m	896 ft-lb
Bore	130 mm	5.12 in
Stroke	140 mm	5.51 in
Displacement	11.1 L	677 in ³

- Caterpillar engine with ACERT™ Technology – EPA Tier III, EU Stage III Compliant
- These ratings apply at 1,800 rpm when tested under the specified standard conditions.
- Rating for net power advertised based on power available when the engine is equipped with alternator, air cleaner, muffler and on-demand hydraulic fan drive at maximum fan speed.

Weights

Operating Weight	23 698 kg	52,254 lb
------------------	-----------	-----------

- For 4.25 m³ (5.5 yd³) general purpose bucket with BOCE

Buckets

Bucket Capacities	3.4-4.2 m ³	4.5-5.5 yd ³
Max Bucket Capacity	4.2 m ³	5.5 yd ³

Operating Specifications

Static Tipping Load, Full Turn	15 474 kg	34,120 lb
Breakout Force	188 kN	42,300 lb

- For 4.25 m³ (5.5 yd³) general purpose bucket with BOCE

Transmission

Forward 1	6.7 km/h	4.2 mph
Forward 2	12.6 km/h	7.8 mph
Forward 3	22.1 km/h	13.7 mph
Forward 4	37.4 km/h	23.2 mph
Reverse 1	7.4 km/h	4.6 mph
Reverse 2	13.9 km/h	8.6 mph
Reverse 3	24.3 km/h	15.1 mph
Reverse 4	37.4 km/h	23.2 mph

- Maximum travel speeds (26.5-25 tires).

Hydraulic System

Bucket/Work Tool System – Pump Output	305 L/min	80.6 gal/min
Steering System Pump Type	Piston	
Hydraulic Cycle Time – Raise	5.9 Seconds	
Hydraulic Cycle Time – Dump	1.6 Seconds	
Hydraulic Cycle Time – Lower, Empty, Float Down	2.4 Seconds	
Hydraulic Cycle Time – Total	9.9 Seconds	

- Implement System (Standard), Piston Pump – Rated at 2,100 rpm and 1,000 psi (6900 kPa).
- Cycle time with rated payload

Brakes

Brakes	Meets required standards.
--------	---------------------------

- Meet OSHA, SAE J1473 OCT90 and ISO 3450-1985 standards.

Axles

Front	Fixed front	
Rear	Oscillating ± 13°	
Maximum Single-Wheel Rise and Fall	502 mm	19.8 in

Tires

Tires	Choose from a variety of tires to match your application.
-------	---

- Choice of:
 - 26.5R25, L-2
 - 26.5R25, L-3 (XHA)
 - 26.5R25, L-5 (VSDL)
 - 26.5-25, L-3 (SRG, SHRL)
 - 750/65R25, L-3
- NOTE: In certain applications (such as load and carry) the loader's productive capabilities might exceed the tires' tonnes-km/h (ton-mph) capabilities. Caterpillar recommends that you consult a tire supplier to evaluate all conditions before selecting a tire model. The 26.5-25 size range and other special tires are available on request.

Cab

ROPS/FOPS Meets SAE and ISO standards.

- Caterpillar cab with integrated Rollover Protective Structure (ROPS) are standard in North America and Europe.
- ROPS meets SAE J1040 APR88 and ISO 3471:1994 criteria.
- Falling Objects Protective Structure (FOPS) meets SAE J231 JAN81 and ISO 3449:1992 Level II criteria.
- The operator sound pressure level measured according to the procedures specified in ISO 6394:1998 is 75 dB(A) for the cab offered by Caterpillar, when properly installed and maintained and tested with the doors and windows closed.
- Hearing protection may be needed when operating with an open operator station and cab (when not properly maintained or doors/windows open) for extended periods or in noisy environments.
- The sound power level is 111 dB(A) measured according to the dynamic test procedure and conditions specified in ISO 6395:1998 for a standard machine configuration.

Service Refill Capacities

Fuel Tank – Standard	380 L	100.4 gal
Cooling System	39 L	10.3 gal
Crankcase	35 L	9.25 gal
Transmission	44 L	11.62 gal
Differentials and Final Drives – Front	64 L	16.9 gal
Differentials and Final Drives – Rear	64 L	16.9 gal
Hydraulic Tank	110 L	29 gal

Operating Specifications

Bucket		General Purpose Buckets					
		Teeth	Teeth and Segments	Bolt-On Edges	Teeth	Teeth and Segments	Bolt-On Edges
Rated Bucket Capacity (§)	m ³	3.50	3.65	3.65	3.65	3.80	3.80
	yd ³	4.50	4.75	4.75	4.75	5.00	5.00
Struck Capacity (§)	m ³	2.96	3.10	3.10	3.12	3.27	3.27
	yd ³	3.88	4.06	4.06	4.08	4.27	4.27
Width (§)	mm	3145	3145	3059	3145	3145	3059
	ft/in	10'4"	10'4"	10'0"	10'4"	10'4"	10'0"
Dump Clearance at Full Lift and 45° Discharge (§)	mm	3005	3005	3154	2968	2968	3119
	ft/in	9'10"	9'10"	10'4"	9'9"	9'9"	10'3"
Reach at Full Lift and 45° Discharge (§)	mm	1389	1389	1247	1411	1411	1270
	ft/in	4'7"	4'7"	4'1"	4'8"	4'8"	4'2"
Reach with Lift Arm Horizontal and Bucket Level (§)	mm	2857	2857	2652	2900	2900	2695
	ft/in	9'4"	9'4"	8'8"	9'6"	9'6"	8'10"
Digging Depth (§)	mm	78	108	108	78	108	108
	in	3.07	4.25	4.25	3.07	4.25	4.25
Overall Length	mm	8995	8995	8770	9038	9038	8813
	ft/in	29'6"	29'6"	28'9"	29'8"	29'8"	28'11"
Overall Height with Bucket at Full Raise	mm	5775	5775	5775	5814	5814	5814
	ft/in	18'11"	18'11"	18'11"	19'1"	19'1"	19'1"
Loader Clearance Circle with Bucket in Carry Position (§)	mm	14 733	14 733	14 528	14 756	14 756	14 550
	ft/in	48'4"	48'4"	47'8"	48'5"	48'5"	47'9"
Static Tipping Load Straight *	kg	17 763	17 401	17 585	17 649	17 290	17 475
	lb	39,167	38,369	38,775	38,916	38,124	38,532
Static Tipping Load Full 37° Turn	kg	15 824	15 480	15 665	15 717	15 375	15 560
	lb	34,892	34,133	34,541	34,656	33,902	34,310
Breakout Force ** (§)	kN	216	200	202	208	193	195
	lb	48,600	45,000	45,450	46,800	43,425	43,875
Operating Weight * (§)	kg	23 520	23 672	23 532	23 576	23 728	23 588
	lb	51,862	52,197	51,888	51,985	52,320	52,012

(§) Specifications and ratings conform to all applicable standards recommended by the Society of Automotive Engineers, including SAE Standard J732C governing loader ratings.

* Static tipping loads and operating weights shown are based on standard machine configuration with 26.5R25 L-4 Firestone tires, roading fenders, powertrain guard, full fuel tank, coolants, lubricants, air conditioner and operator.

** Measured 102 mm (4.0") behind tip of cutting edge with bucket hinge pin as pivot point in accordance with SAE J732C.

Bucket Selection Guide

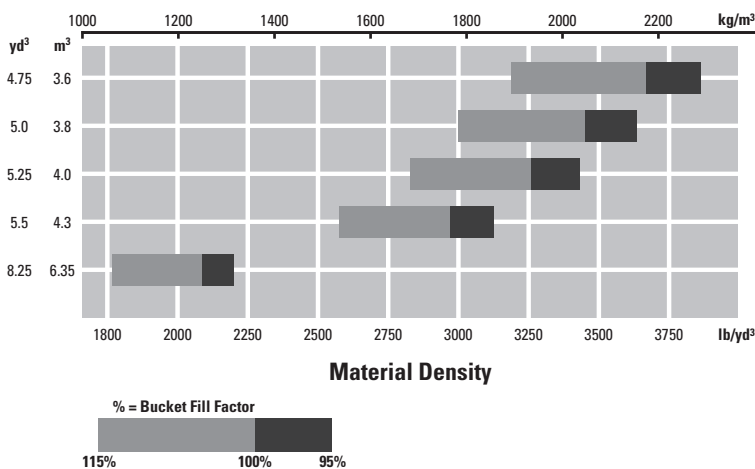

Bucket		General Purpose Buckets					
		Teeth	Teeth and Segments	Bolt-On Edges	Teeth	Teeth and Segments	Bolt-On Edges
Rated Bucket Capacity (§)	m ³	3.80	4.00	4.00	4.00	4.25	4.25
	yd ³	5.00	5.25	5.25	5.25	5.50	5.50
Struck Capacity (§)	m ³	3.28	3.43	3.43	3.43	3.62	3.62
	yd ³	4.29	4.48	4.48	4.48	4.73	4.73
Width (§)	mm	3145	3145	3059	3306	3306	3220
	ft/in	10'4"	10'4"	10'0"	10'10"	10'10"	10'7"
Dump Clearance at Full Lift and 45° Discharge (§)	mm	2934	2934	3086	2934	2934	3086
	ft/in	9'8"	9'8"	10'2"	9'8"	9'8"	10'2"
Reach at Full Lift and 45° Discharge (§)	mm	1434	1434	1294	1434	1434	1294
	ft/in	4'8"	4'8"	4'3"	4'8"	4'8"	4'3"
Reach with Lift Arm Horizontal and Bucket Level (§)	mm	2942	2942	2737	2942	2942	2737
	ft/in	9'8"	9'8"	9'0"	9'8"	9'8"	9'0"
Digging Depth (§)	mm	78	108	108	78	108	108
	in	3.07	4.25	4.25	3.07	4.25	4.25
Overall Length	mm	9080	9080	8855	9080	9080	8855
	ft/in	29'9"	29'9"	29'1"	29'9"	29'9"	29'1"
Overall Height with Bucket at Full Raise	mm	5853	5853	5853	5853	5853	5853
	ft/in	19'2"	19'2"	19'2"	19'2"	19'2"	19'2"
Loader Clearance Circle with Bucket in Carry Position (§)	mm	14 778	14 778	14 572	14 924	14 924	14 720
	ft/in	48'6"	48'6"	47'10"	49'0"	49'0"	48'3"
Static Tipping Load Straight *	kg	17 655	17 196	17 382	17 567	17 178	17 394
	lb	38,929	37,917	38,327	38,735	37,877	38,354
Static Tipping Load Full 37° Turn	kg	15 626	15 286	15 472	15 631	15 258	15 474
	lb	34,455	33,706	34,116	34,466	33,644	34,120
Breakout Force ** (§)	kN	200	186	188	200	186	188
	lb	45,000	41,850	42,300	45,000	41,850	42,300
Operating Weight * (§)	kg	23 610	23 762	23 622	23 674	23 865	23 698
	lb	52,060	52,395	52,087	52,201	52,622	52,254

(§) Specifications and ratings conform to all applicable standards recommended by the Society of Automotive Engineers, including SAE Standard J732C governing loader ratings.

* Static tipping loads and operating weights shown are based on standard machine configuration with 26.5R25 L-4 Firestone tires, roading fenders, powertrain guard, full fuel tank, coolants, lubricants, air conditioner and operator.

** Measured 102 mm (4.0") behind tip of cutting edge with bucket hinge pin as pivot point in accordance with SAE J732C.

Operating Specifications

Bucket		Material Handling Buckets					
		Teeth	Teeth and Segments	Bolt-On Edges	Teeth	Teeth and Segments	Bolt-On Edges
Rated Bucket Capacity (§)	m ³	3.65	3.80	3.80	3.80	4.00	4.00
	yd ³	4.75	5.00	5.00	5.00	5.25	5.25
Struck Capacity (§)	m ³	3.08	3.22	3.22	3.31	3.46	3.46
	yd ³	4.02	4.21	4.21	4.33	4.52	4.52
Width (§)	mm	3306	3306	3220	3306	3306	3220
	ft/in	10'10"	10'10"	10'7"	10'10"	10'10"	10'7"
Dump Clearance at Full Lift and 45° Discharge (§)	mm	2920	2920	3083	2878	2878	3041
	ft/in	9'7"	9'7"	10'1"	9'5"	9'5"	10'0"
Reach at Full Lift and 45° Discharge (§)	mm	1254	1254	1127	1297	1297	1170
	ft/in	4'1"	4'1"	3'8"	4'3"	4'3"	3'10"
Reach with Lift Arm Horizontal and Bucket Level (§)	mm	2847	2847	2642	2907	2907	2702
	ft/in	9'4"	9'4"	8'8"	9'6"	9'6"	8'10"
Digging Depth (§)	mm	78	108	108	78	108	108
	in	3.07	4.25	4.25	3.07	4.25	4.25
Overall Length	mm	8985	8985	8760	9045	9045	8820
	ft/in	29'6"	29'6"	28'9"	29'8"	29'8"	28'11"
Overall Height with Bucket at Full Raise	mm	5748	5748	5748	5803	5803	5803
	ft/in	18'10"	18'10"	18'10"	19'0"	19'0"	19'0"
Loader Clearance Circle with Bucket in Carry Position (§)	mm	14 875	14 875	14 672	14 906	14 906	14 702
	ft/in	48'10"	48'10"	48'2"	48'11"	48'11"	48'3"
Static Tipping Load Straight *	kg	17 519	17 124	17 336	17 366	16 974	17 186
	lb	38,629	37,758	38,226	38,292	37,428	37,895
Static Tipping Load Full 37° Turn	kg	15 598	15 220	15 431	15 452	15 077	15 289
	lb	34,394	33,560	34,025	34,072	33,245	33,712
Breakout Force ** (§)	kN	217	201	203	206	191	193
	lb	48,825	45,225	45,675	46,350	42,975	43,425
Operating Weight * (§)	kg	23 599	23 790	23 623	23 670	23 861	23 694
	lb	52,036	52,457	52,089	52,192	52,614	52,245

(§) Specifications and ratings conform to all applicable standards recommended by the Society of Automotive Engineers, including SAE Standard J732C governing loader ratings.

* Static tipping loads and operating weights shown are based on standard machine configuration with 26.5R25 L-4 Firestone tires, roading fenders, powertrain guard, full fuel tank, coolants, lubricants, air conditioner and operator.

** Measured 102 mm (4.0") behind tip of cutting edge with bucket hinge pin as pivot point in accordance with SAE J732C.

Bucket		Quick Coupler General Purpose Buckets			Rock Buckets		Heavy Duty Rock Buckets
		Teeth	Teeth and Segments	Bolt-On Edges	Bolt-On Edges	Teeth and Segments	Teeth and Segments
Rated Bucket Capacity (§)	m ³	3.65	3.85	3.85	3.50	3.50	3.50
	yd ³	4.75	5.00	5.00	5.00	5.00	5.00
Struck Capacity (§)	m ³	3.16	3.31	3.31	2.99	2.99	2.99
	yd ³	4.13	4.33	4.33	3.91	3.91	3.91
Width (§)	mm	3145	3145	3059	3283	3270	3270
	ft/in	10'4"	10'4"	10'0"	10'9"	10'9"	10'9"
Dump Clearance at Full Lift and 45° Discharge (§)	mm	2843	2843	2995	3114	2965	2965
	ft/in	9'4"	9'4"	9'10"	10'3"	9'9"	9'9"
Reach at Full Lift and 45° Discharge (§)	mm	1520	1520	1380	1423	1612	1612
	ft/in	5'0"	5'0"	4'6"	4'8"	5'3"	5'3"
Reach with Lift Arm Horizontal and Bucket Level (§)	mm	3068	3068	2863	2799	3004	3004
	ft/in	10'1"	10'1"	9'5"	9'2"	9'10"	9'10"
Digging Depth (§)	mm	88	118	118	113	118	118
	in	3.46	4.65	4.65	4.45	4.65	4.65
Overall Length	mm	9214	9214	8988	8921	9169	9169
	ft/in	30'3"	30'3"	29'6"	29'3"	30'1"	30'1"
Overall Height with Bucket at Full Raise	mm	5762	5762	5762	5736	5736	6063
	ft/in	18'11"	18'11"	18'11"	18'10"	18'10"	19'11"
Loader Clearance Circle with Bucket in Carry Position (§)	mm	14 853	14 853	14 645	14 814	14 935	14 935
	ft/in	48'9"	48'9"	48'1"	48'7"	49'0"	49'0"
Static Tipping Load Straight *	kg	16 965	16 634	16 797	17 380	17 244	17 122
	lb	37,408	36,678	37,037	38,323	38,023	37,754
Static Tipping Load Full 37° Turn	kg	15 103	14 787	14 950	15 439	15 303	15 180
	lb	33,302	32,605	32,965	34,043	33,743	33,472
Breakout Force ** (§)	kN	179	168	169	178	180	179
	lb	40,275	37,800	38,025	40,050	40,500	40,275
Operating Weight * (§)	kg	23 516	23 668	23 528	23 867	23 969	24 129
	lb	51,853	52,188	51,879	52,627	52,852	53,204

(§) Specifications and ratings conform to all applicable standards recommended by the Society of Automotive Engineers, including SAE Standard J732C governing loader ratings.

* Static tipping loads and operating weights shown are based on standard machine configuration with 26.5R25 L-4 Firestone tires, roading fenders, powertrain guard, full fuel tank, coolants, lubricants, air conditioner and operator.

** Measured 102 mm (4.0") behind tip of cutting edge with bucket hinge pin as pivot point in accordance with SAE J732C.

Operating Specifications

Bucket		Waste Bucket	High Lift
		Bolt-On Edges	Change in Specs
Rated Bucket Capacity (§)	m ³	6.50	
	yd ³	8.50	
Struck Capacity (§)	m ³	5.43	
	yd ³	7.10	
Width (§)	mm	3355	
	ft/in	11'0"	
Dump Clearance at Full Lift and 45° Discharge (§)	mm	2989	558
	ft/in	9'10"	1'10"
Reach at Full Lift and 45° Discharge (§)	mm	1185	-16
	ft/in	3'10"	-1.0"
Reach with Lift Arm Horizontal and Bucket Level (§)	mm	2750	
	ft/in	9'0"	
Digging Depth (§)	mm	134	-5
	in	5.28	-0.20
Overall Length	mm	8888	328
	ft/in	29'2"	1'1"
Overall Height with Bucket at Full Raise	mm	6500	549
	ft/in	21'4"	1'10"
Loader Clearance Circle with Bucket in Carry Position (§)	mm	14 871	124
	ft/in	48'9"	5.0"
Static Tipping Load Straight *	kg	17 893	177
	lb	39,454	390
Static Tipping Load Full 37° Turn	kg	15 860	-3
	lb	34,971	-7
Breakout Force ** (§)	kN	182	-13
	lb	40,950	-2,864
Operating Weight * (§)	kg	24 237	1746
	lb	53,443	3,850

(§) Specifications and ratings conform to all applicable standards recommended by the Society of Automotive Engineers, including SAE Standard J732C governing loader ratings.

* Static tipping loads and operating weights shown are based on standard machine configuration with 26.5R25 L-4 Firestone tires, roading fenders, powertrain guard, full fuel tank, coolants, lubricants, air conditioner and operator.

** Measured 102 mm (4.0") behind tip of cutting edge with bucket hinge pin as pivot point in accordance with SAE J732C.

Dimensions

All dimensions are approximate.

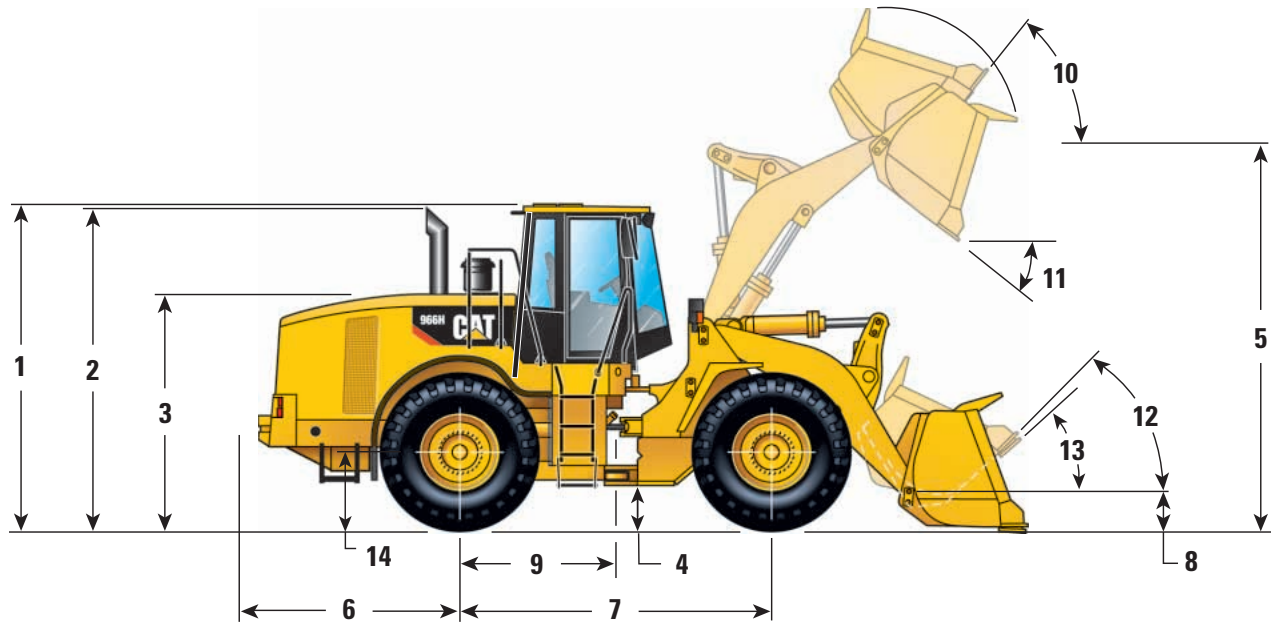

1	Height to top of ROPS	3600 mm (11'10")
2	Height to top of exhaust pipe	3552 mm (11'8")
3	Height to top of hood	2678 mm (8'9")
4	Ground clearance with 26.5R25 L-4 Firestone (see tire chart for other tires)	496 mm (1'8")
5	B-Pin height	4224 mm (13'10")
6	Center line of rear axle to edge of counterweight	2461 mm (8'1")
7	Wheelbase	3450 mm (11'4")
8	B-Pin height @ carry	507 mm (1'8")
9	Center line of rear axle to hitch	1725 mm (5'8")
10	Rack back @ maximum lift	60.8
11	Dump angle @ maximum lift	45
12	Rack back @ carry	47.4
13	Rack back @ ground	41.8
14	Height to center line of axle	815 mm (2'8")

Tire Dimensions/Specifications

	Width over tires		Change in vertical dimensions		Change in operating weight		Change in static tipping load	
	mm	inches	mm	inches	kg	lb	kg	lb
26.5R25 GP2B GY L2 Radial	3012	119	-20	-0.8	-82	-181	-67	-148
26.5R25 VMT BS L3 Radial	3015	119	-30	-1.2	48	106	-45	-99
26.5R25 RT3B GY L3 Radial	3017	119	-20	-0.8	-24	-53	-24	-53
26.5R25 XHA MX L3 Radial	3017	119	-20	-0.8	-34	-75	-31	-68
26.5R25 VSDL BS L5 Radial	2956	116	0	0.0	1214	2,677	906	1,998
750/65R25 MX L3 Radial Low Profile	3076	121	-20	-0.8	-262	-578	-52	-115
26.5-25 20 PR SRG FS L3 Bias	2992	118	-44	-1.7	-358	-789	-492	-1,085
26.5-25 20 PR SHRL GY L3 Bias	2974	117	-20	-0.8	7	15	-158	-348
26.5-25 SRG DT FS LDL4 Bias	3002	118	0	0.0	0	0	0	0

NOTE: Tread width for 26.5-25 is 2230 mm (7'4")

Standard Equipment

Standard equipment may vary. Consult your Caterpillar dealer for details.

ELECTRICAL

- Alarm, back-up
- Alternator, 80-amp brushless
- Batteries, Maintenance free (2) 1400 CCA
- Ignition key; start/stop switch
- Lighting system, halogen (6 total)
- Main disconnect switch
- Receptacle, starting, 24-volt
- Starter, electric, heavy-duty
- Starting and charging system (24-volt)

OPERATOR ENVIRONMENT

- Air conditioner, heater and defroster
- Bucket/work tool function lockout
- Cab, pressurized and sound-suppressed ROPS/FOPS
 - Radio-ready (entertainment) includes antenna, speakers and converter (12-volt, 10-amp)
- Cigar lighter and ashtray (12-volt)
- Coat hook (2) with straps
- Computerized monitoring system
 - Instrumentation, gauges:
 - Digital gear range indicator
 - Engine coolant temperature
 - Fuel level
 - Hydraulic oil temperature
 - Speedometer/tachometer
 - Transmission oil temperature
 - Instrumentation, warning indicators:
 - Axle oil temperature
 - Electrical, alternator output
 - Engine air filter restriction
 - Engine inlet manifold temperature
 - Engine oil pressure
 - Fuel level
 - Fuel pressure, hi/low
 - Hydraulic filter bypass
 - Hydraulic oil level
 - Parking brake
 - Primary steering oil pressure
 - Service brake oil pressure
 - Transmission filter bypass
- Controls, electrohydraulic, lift and tilt function
- Horn, electric (steering wheel/console)
- Light, dome (cab)
- Lunchbox, beverage holders and personal tray
- Mirror, rearview (internally mounted)
- Seat, Cat Comfort (cloth) with air suspension
- Seat belt, retractable, 51 mm (2") wide
- Steering column, adjustable angle (SW-CCS) and length (CCS)
- Wet-Arm wipers and washers, front and rear
 - Intermittent front wipers
- Window, sliding (left and right side)

POWER TRAIN

- Brakes, full hydraulic enclosed wet-disc with Integrated Braking System (IBS) and brake wear indicator
- Engine, Cat C11 with ACERT™ Technology and ATAAC
- Fan, radiator, electronically controlled, hydraulically driven, temperature sensing, on demand
- Filters, fuel, primary/secondary
- Filters, engine air, primary/secondary
- Fuel priming pump (electric)
- Muffler, sound suppressed
- Radiator, unit core
- Starting aid, ether (ready)
- Switch, transmission neutralizer lockout
- Torque converter, free wheel stator
- Transmission, automatic, planetary powershift (4F/4R)
- Variable Shift Control (VSC)

OTHER

- Automatic bucket positioner
- Counterweight
- Couplings, Caterpillar O-ring face seal
- Doors, service access (locking)
- Ecology drains, engine, transmission and hydraulics
- Fenders, steel (front and rear)
- Guard, airborne debris
- Hitch, drawbar with pin
- Hood, non-metallic, power tilting
- Hoses, Caterpillar XT™
- Hydraulic oil cooler
- Kickout, lift and tilt, automatic (in-cab adjustable)
- Linkage, Z-bar, cast crosstube/tilt lever
- Oil sampling valves
- Product Link ready
- Remote diagnostic pressure taps
- Service center, electrical and hydraulic
- Sight gauges:
 - Engine coolant
 - Hydraulic oil
 - Transmission oil level
- Steering, load sensing
- Vandalism protection caplocks

TIRES, RIMS, WHEELS

A tire must be selected from the mandatory attachments section. Base machine price includes an allowance based on a premium radial tire.

ANTIFREEZE

Premixed 50% concentration of Extended Life Coolant with freeze protection to -34° C (-29° F)

Optional Equipment

Optional equipment may vary. Consult your Caterpillar dealer for details.

Aggregate Autodig System
Autolube
Buckets and work tools
Bucket Ground Engaging Tools (GET) – see Cat dealer for details
Camera, rear vision
Cooler, axle oil
Cooling, high-ambient, 50° C (122° F)
Differentials
 Limited slip, front or rear
 NO-SPIN, rear
Drain, axle ecology
Fender extensions, front and rear
Fenders, narrow
Fenders, roading
Glass, cab, rubber-mounted
Guard, axle seal
Guard, front window, wide or small mesh
Guard, power train
Guard, vandalism
Heater, engine coolant, 120- or 240-volt
Hydraulic arrangement, three-valve
Joystick control, two- or three-valve
Lights, directional
Lights, high intensity discharge (HID)
Lights, roading
Light, warning beacon
Lights, work, cab-mounted
Machine Security System
Mirrors, external
Mirrors, heated external
Mirrors, heated external, folding
Open canopy
Payload Control System
 Payload Control System Printer
Platform, window cleaning
Precleaner, turbine
Precleaner, turbine/trash
Product Link
Radio, AM/FM Weatherband (CD)
Radio, CB-ready
Remote pressure taps, transmission
Ride Control System, two- or three-valve
Seat, heated
Seatbelt, 76 mm (3") wide
Sound suppression, exterior
Steering, Command Control System
Steering, secondary
Switch, lift lever FNR (steering wheel machines)
Sun visor, front
Tool box
Special Machine Arrangements
 High Lift Arrangement, two- and three-valve
 Forest Machine Arrangement
 Industrial Loader Arrangement
 Yard Loader Value Package

966H Wheel Loader

For more complete information on Cat products, dealer services,
and industry solutions, visit us on the web at www.cat.com

© 2007 Caterpillar
All Rights Reserved
Printed in U.S.A.

Materials and specifications are subject to change without notice.
Featured machines in photos may include additional equipment.
See your Caterpillar dealer for available options.

CAT, CATERPILLAR, their respective logos, ACERT, "Caterpillar Yellow" and the
POWER EDGE trade dress, as well as corporate and product identity used herein,
are trademarks of Caterpillar and may not be used without permission.

AEHQ5657-02 (5-07)
Replaces AEHQ5657-01

CATERPILLAR[®]