

D6R

Track-Type Tractor



Standard, XL, XR & LGP

Cat® 3306 turbocharged diesel engine at flywheel power

Standard	123 kW	165 HP
XL/XR arrangements	130 kW	175HP
LGP arrangement	138 kW	185 HP

Operating weight (power shift model)

Standard arrangement	18 000 kg	39,700 lb
XL arrangement	19 000 kg	41,900 lb
XR arrangement	18 300 kg	40,400 lb
LGP arrangement	20 500 kg	45,200 lb

Blade capacity, up to:

Straight	3.89 m ³	5.09 yd ³
Semi-Universal	5.61 m ³	7.34 yd ³
Angle (std/XR)	3.18 m ³	4.16 yd ³
Angle (XL)	3.93 m ³	5.14 yd ³
Straight (LGP)	3.70 m ³	4.83 yd ³

D6R Track-Type Tractor

The D6R's power, response and control deliver more production at lower cost-per-yard.

Power Train

The reliable Caterpillar® 3306 turbocharged diesel engine has large displacement and high torque rise. A planetary power shift transmission permits fast speed and direction changes. **pg.4**

Torque Divider

An exclusive Caterpillar designed torque divider allows the engine to respond quickly to varying work loads. **pg. 5**

Cooling System

- ✓ *The Advanced Modular Cooling System (AMOCS) combines a more efficient cooling system with easier servicing. AMOCS allows the machine to be operated in the most demanding environment. **pg. 5***

Engineered for demanding work. The D6R's durable construction is made for tough working conditions. It keeps material moving with the reliability and low operating costs you expect from Cat machines.



Undercarriage

The elevated sprocket moves the final drives above the work area, isolating them from ground impacts. The different undercarriage configuration allows you to match the tractor to the working conditions. **pg.6**

Operator's Station

- ✓ The *comfortable operator's station* provides excellent viewing area to the blade and rear of the machine for maximum operator productivity. Controls are low-effort and easy to reach. Cat Contour Series Seat provides proper support and automotive comfort. The Caterpillar Monitoring System has easy-to-read gauges, which constantly inform the operator of key machine functions. **pg. 8-9**

Steering

- ✓ Choose from *differential steering*, which directs uninterrupted power to
- ✓ both tracks, or *Finger Tip Control*. Both systems allow simultaneous, one-hand steering and transmission control for increased operator efficiencies. **pg. 10**

Work Tools

The variety of bulldozer blades, rippers and winches allow you to customize the D6R to match your specific application. **pg.11**

Serviceability

Major modular components are designed for excellent serviceability and allow fast in-field component exchange. **pg.12**

Customer Service

The best parts availability and service capability. **pg 12**

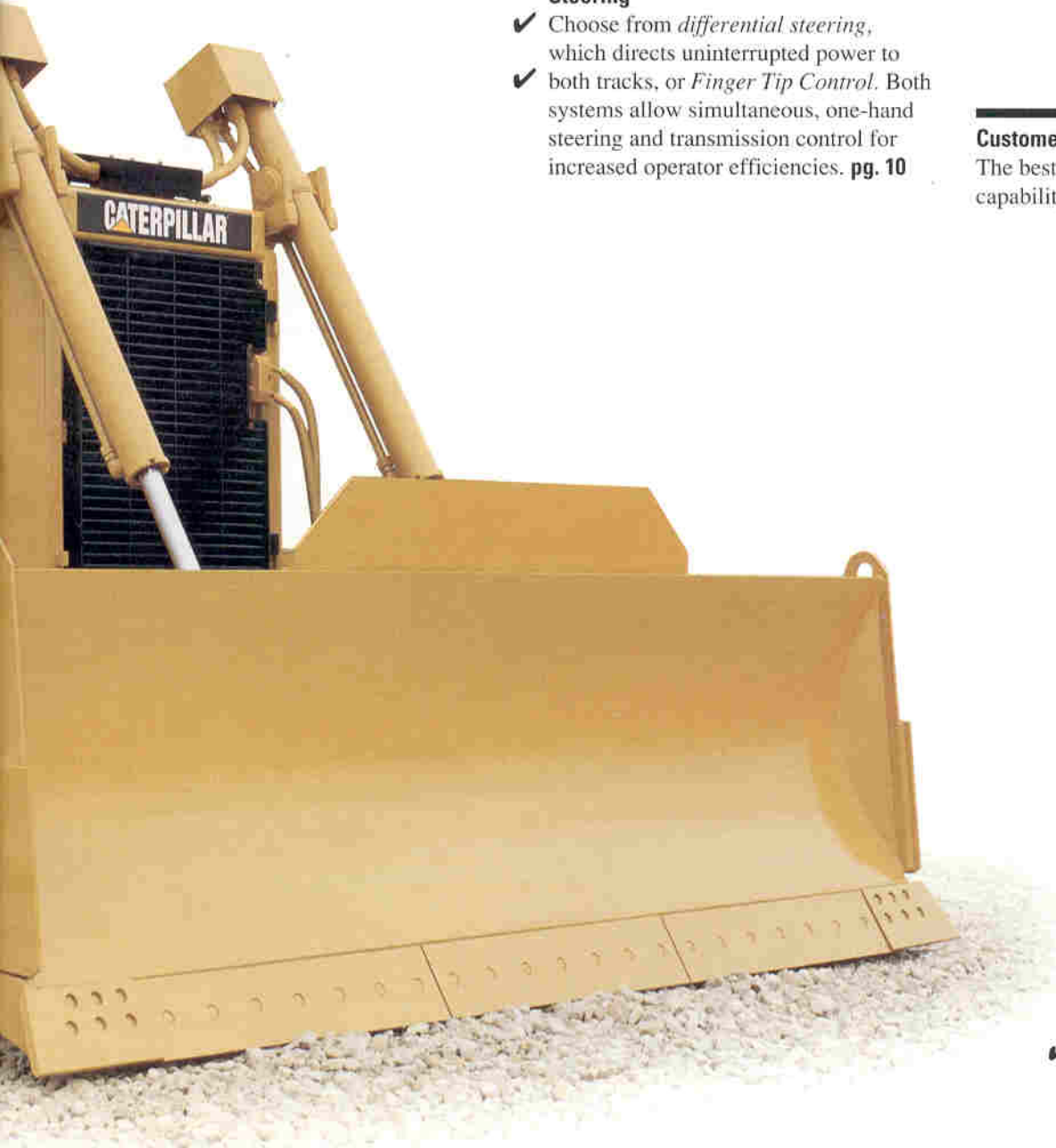

✓ *New feature*

Power Train

Reliable...durable...efficient!

Turbocharged 3306 diesel engine

delivers plenty of power for quick response, big loads.

Large displacement, high torque rise and low RPM rating for low stress, long life.

High torque rise offers superior lugging capabilities—keep moving through tough spots without downshifting.

Direct fuel injection precisely meters fuel for maximum productivity per unit of fuel.

Good weight-to-horsepower ratio — faster loading, bigger loads, shorter cycle times.

1 Turbocharger

2 Nozzle assemblies

3 Cat fuel injection system

4 Aluminum alloy piston

5 Forged crankshaft

6 Valves (intake, exhaust)

7 Oil cooler

8 Cylinder, full-length, water-cooled

9 Cooling jets

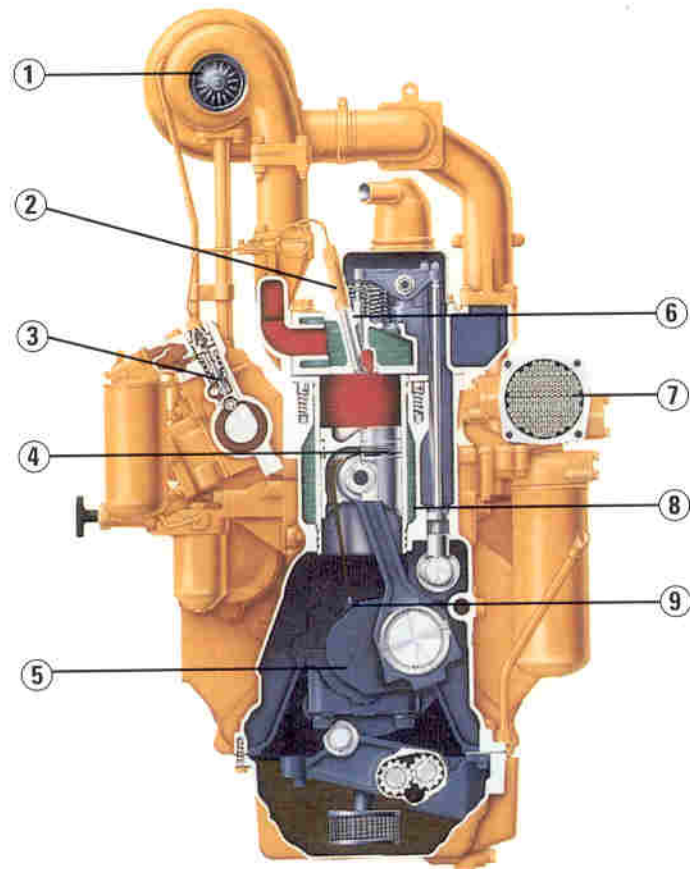

Planetary Power Shift Transmission

has 3-speeds forward and 3-speeds reverse and utilizes large diameter, high-capacity, oil-cooled clutches.

- Modulation system permits fast speed and direction changes.
- Modular transmission and bevel gear slide into rear case for servicing ease, even with ripper installed.
- Oil-to-water cooler for maximum cooling capacity.
- Forced oil flow lubricates and cools clutch packs to provide maximum clutch life.

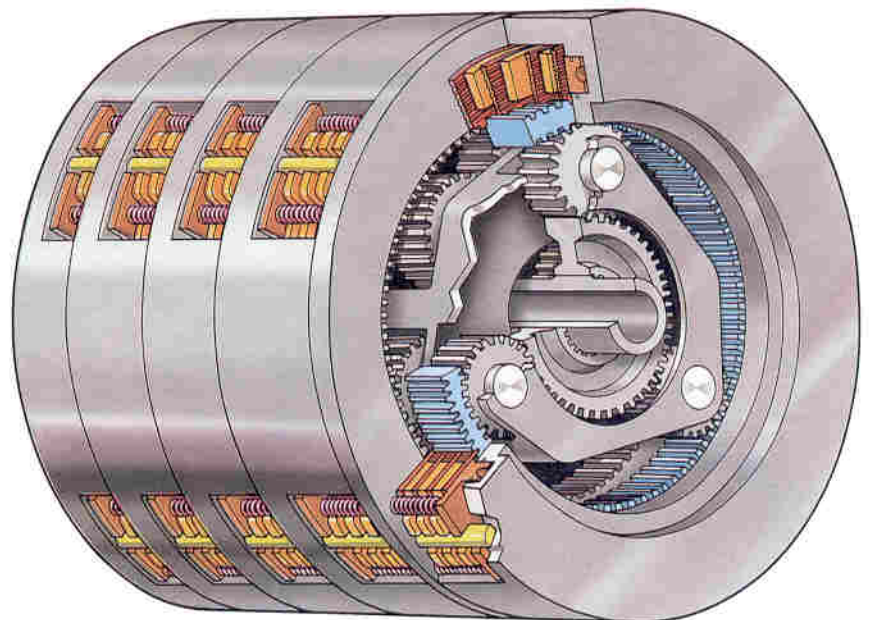

Torque Divider. A single-stage torque converter with output torque divider sends 70% of engine torque through the converter, 30% through a direct drive shaft for greater driveline efficiency and higher torque multiplication.

The torque converter shields the driveline from sudden torque shocks and vibration.

- 1 Ring gear
- 2 Flywheel
- 3 Sun gear
- 4 Planet gear
- 5 Turbine
- 6 Impeller
- 7 Stator
- 8 Output shaft

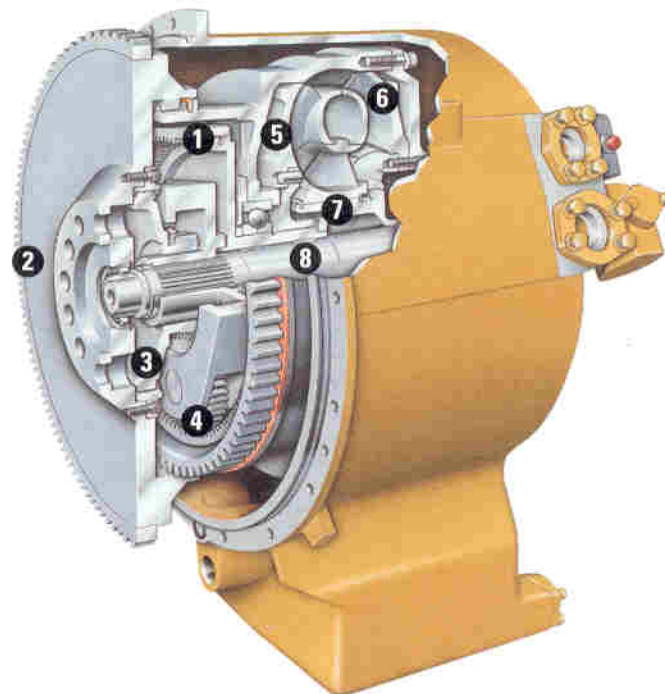

Advanced Modular cooling system (AMOCS) utilizes an exclusive two pass cooling system and increased cooling surface area to provide a more efficient heat transfer system than conventional systems.

Two pass cooling system circulates coolant from the sectioned bottom tank (1) up through one side (2) of the cooling element and down through the other side (3) returning it to the bottom tank.

The cooling elements are individual core modules that are connected to a sectioned bottom tank. There is no top tank to remove.

- 9 steel fins per inch.
- Brass tube construction within each core.

The servicing of the AMOCS can be performed without tilting the radiator guard.

- No need to remove or replace a major component as on single-core radiators.
- Each core module can be replaced individually (without removing the entire radiator or tilting the radiator guard), saving considerable cost and repair time.

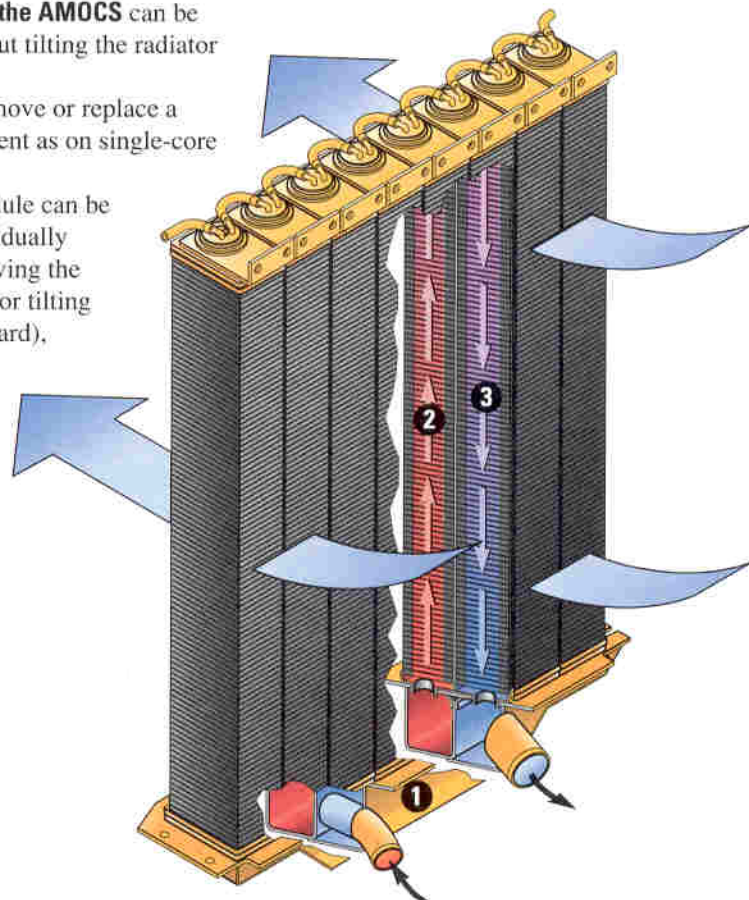

Elevated Sprocket Undercarriage

The Caterpillar elevated sprocket undercarriage arrangements allow optimized balance for the best possible performance in each application.



Final drives and associated power train components raised above the work area — isolating them from ground-induced impact loads, as well as implement and roller frame alignment loads — extending power train component life.

Sprocket position keeps sprocket teeth, bushings and final drives away from the abrasive materials and moisture — resulting in longer final drive gear and seal life.



High flange improved track rollers

(optional) combined with center or full length roller guard attachments greatly improve track guiding for demanding side slope or impact conditions.

Rotating Bushing Track (optional) is sealed and lubricated system which includes four track seals per joint, non-restrained floating bushings, longer track pins, redesigned track links (wider pin boss and bushing strap, and taller

rail) and a unique pin retention system. Because the bushings rotate, relative motion between the bushings and the sprocket teeth is virtually eliminated. The minimal wear that does occur is evenly distributed around the bushings. Therefore, no bushing turn is required, and sprocket segment wear is dramatically reduced. In effect, RBT does an ongoing bushing turn as the machine works.

Standard arrangement

- A general purpose undercarriage that performs well in many applications with firm underfoot conditions.

XL arrangement

- Delivers unmatched performance in general dozing applications.
- More track to the front provides a balanced platform for superior traction, blade control and stability for finish grading.
- Carrier roller for improved fine dozing performance.

XR arrangement

- XR undercarriage is built to excel in drawbar, skidding, and ripping applications.
- With more track to the rear, the tractor's weight is positioned forward, which increases traction and stability for drawbar applications.

LGP arrangement

- LGP undercarriage is designed to work in soft and spongy conditions.
- Wide track shoes and long track frame increases track contact area, reducing ground pressure for excellent flotation in swampy conditions.

Heavy duty track link

- Standard on all D6R configurations.
- Increased durability of link assembly. Components will provide improved strength and greater retention between the link, pin and bushing offering:
 - Improved sealability.
 - Increased link and roller system wear life.
- Track shoes.
 - Choice of moderate service or extreme service shoes in a variety of widths allows you to further tailor the tractor to meet your requirements.
 - Self-cleaning shoes are available for the LGP arrangement.

Standard Arrangement

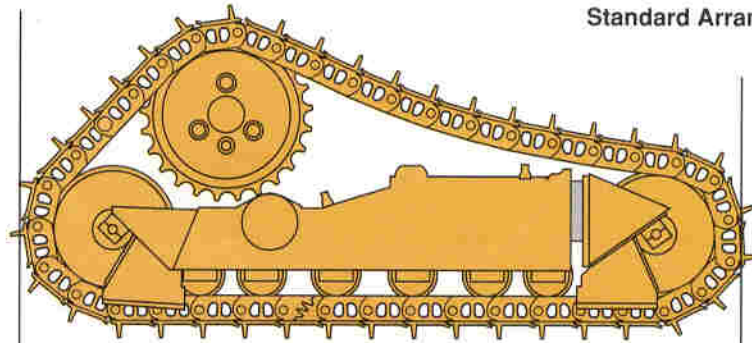

XL Arrangement

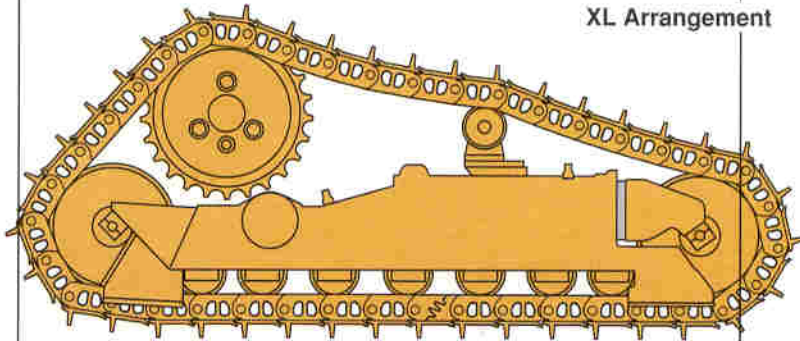

XR Arrangement

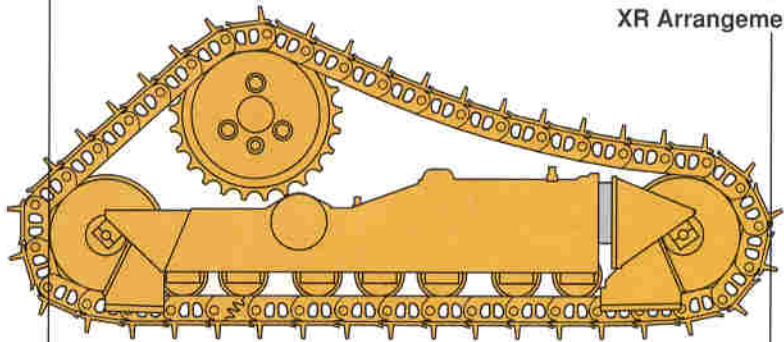

LGP Arrangement

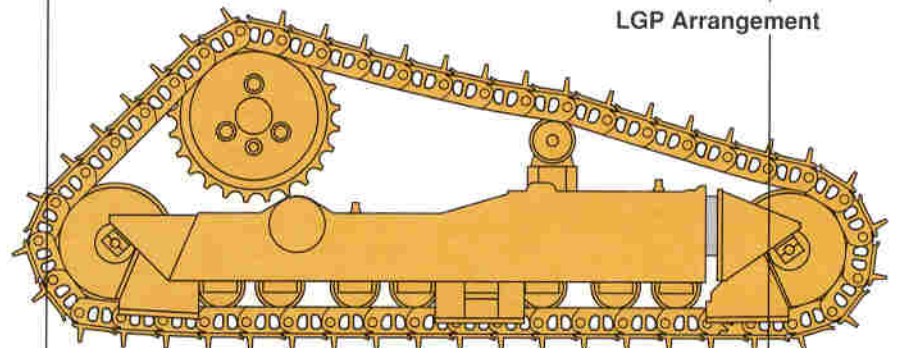

Operator's Station

Comfort and convenience designed into the control station for an efficient and productive operator.





Operator's station provides excellent viewing area to blade and rear of machine for maximum operator productivity. Several enhancements have been added to the cab to improve operator comfort, reduce fatigue, increase productivity, and reduce interior sound levels.

Easy-to-reach, low-effort controls provide sure, precise steering and dozer control for less operator fatigue.

- 1 Differential steering's** dual twist tiller provides excellent maneuverability and one-handed control.
- 2 Finger Tip Controls** are easily accessible, and allow exceptional one-handed maneuverability
- 3 Instrument panel** includes standard gauge group with fuel gauge and computerized Caterpillar Monitoring System for monitoring critical machine functions. The Caterpillar Monitoring System includes a switchable digital display so that the operator can scroll through displays for gear selection, hour meter, diagnostic codes and other vital information.

Isolation-mounted cab (optional) with air pressurizer and heater reduces noise and vibration for shift-long comfort.

Cab, storage compartment and cup holder — for added operator convenience.

- 4 Caterpillar Contour Series Seat** — ergonomically designed and fully adjustable for maximum comfort.
 - Backrest centerline conforms to the operator's spinal curve and also has a transverse curve to provide additional side-to-side support.
 - Fully adjustable seat allows the operator to position for maximum comfort.
 - Retractable 75 mm (3") wide seatbelt for positive, comfortable restraint.

Radio installation group (standard with cab).

- Includes mounting brackets, AM/FM antenna and speakers.
- AM/FM stereo cassette radio, optional.

Sound levels have been reduced by:

- Incorporating acoustical materials to cab interior trim components to absorb and block sound transmission and improve appearance and comfort.
- Redesigning the cab mount system to reduce structurally transmitted noise.
- Modifying Heating/Ventilating/Air Conditioning (HVAC) system to significantly reduce interior sound levels while maintaining performance level.
- Adding rubber boots to the implement controls for improved acoustical and environmental sealing.

Other improvements include:

- Standard hydraulic oil temperature gauge.
- Storage for lunch box, cup and insulated bottle with the acoustical interior.
- Door and post covers to improve appearance.
- Adjustable armrests.
- Kneepads for side slope operations.
- Larger storage box for personal items.
- Window slides provide better sealing.
- Vinyl/foam floor covers have been enlarged to cover the complete floor area, bottom of the left and right control consoles and seat well.



Steering Systems

Choice of Differential Steering or Finger Tip Control for steering and transmission enable fast cycle times, excellent maneuverability and operator comfort.

Differential Steering maintains uninterrupted power to both tracks during turns through a hydraulically actuated planetary differential, and allows simultaneous one-hand steering and transmission control. Automatic shifting features and easier upshifts and downshifts increase operator productivity and reduce operator fatigue.

- Turns accomplished by speeding up one track while equally slowing the other — speed difference turns tractor.
- Operator maintains smooth, precise turning with one lever.
- Provides excellent steering control in tight areas, near structures, or when following grade stakes.
- Greater load, power and speed control where the underfooting is soft or sloppy, because both tracks drive to maintain traction.
- Faster cycles due to quick forward/reverse response, steering/directional control.



Finger Tip Control allows simultaneous, one-hand steering and transmission control. Automatic shifting features and reduced lever efforts provide easier upshift and downshift, increase operator comfort, reduce fatigue and shorten cycle times.

- Padded armrest and ergonomic, molded hand grip.
- Low-effort finger tip levers for steering.
- Touch-shift buttons for upshift and downshift.
- Rotational directional control for forward, neutral and reverse.
- Horizontal and vertical adjustments for operator comfort.
- Parking brake switch electronically locks electronic clutch and brake steering.



Automatic shifting features.

Bi-Directional Auto Shift allows the operator to preselect a forward and reverse gear for directional changes.

Auto-kickdown automatically downshifts the transmission when the engine lugs down to a predetermined RPM level.

Work Tools

Caterpillar work tools include a choice of dozers, rippers and winches designed for efficient, high production.



Blades

- Choice of S, SU and A blades for optimum production.
- High blade heel clearance and sharp cutting edge angle (S, SU blades) — penetrates tough material easily.
- Cat moldboard profile on SU blades loads easily, retains load.
- L-shaped push arms (S, SU) allow blades to be mounted closer to front of unit...higher penetration forces for larger blade loads and excellent maneuverability.
- The A blade is mounted to a C-frame, using a pinned connection — permits blade angling and tilting, left or right.

Ripper

- Multi-shank parallelogram ripper lets you choose up to three shanks, depending on job conditions.
- Caterpillar design allows the operator to see the ripper tip — provides ample throat clearance, high penetration and pryout forces.
- Some application restrictions apply on LGP machines equipped with a ripper.

Winch

- Single lever control actuates both clutch and brake functions to improve operator efficiency. A separate lever is used for freespool operation.
- Input clutches on PTO shaft reduce engine horsepower losses, provide fuel efficiency and economy.
- Clutch engagement and brake release are automatically synchronized for smooth operation.
- Winch components can be serviced with winch mounted on tractor.

Load Sensing Hydraulics

Adjusts implement and hydraulic power to increase both operator and machine efficiency.

Load-sensing hydraulics utilize a feedback loop from the implement valve to the implement pump to continually monitor the hydraulic power requirements of the implement.

During normal blade or ripper corrections the hydraulic pump's flow and pressure output are regulated to only what is needed.

Lower pump requirements can reduce engine power requirements for the hydraulics making, more drawbar power available for increased machine production, higher operator efficiency and increased fuel efficiency.

Service

The Cat elevated sprocket tractor's modular design concept moves a generation ahead in simplified service and repair.

Major components are easily accessible, removable as single units.

Modular design permits fast removal and installation.

Pre-testing modular components before installation or after repair assures quality.

Grouped service points, easy access to service areas make routine checks fast, convenient.

Diagnostic connector for special dealer tool enables fast troubleshooting of starting and charging problems.

Quick, easy service access and inspection.

Ecology drains provide an environmentally safer method to drain fluids. They are included on the radiator, engine and hydraulic tank; optional for the transmission, bevel gear case and torque converter.



Total Customer Support

Unmatched in the industry!

Services. Your Cat dealer offers a wide range of services that can be set up under a customer support agreement when you purchase your equipment. The dealer will help you choose a plan that can cover everything from machine and attachment selection to replacement, to help you get the best return on your investment.

Product support. You will find nearly all parts at our dealer parts counter. Cat dealers utilize a world-wide computer network to find in-stock parts to minimize machine down time. Save money with remanufactured parts. You receive the same warranty and reliability as new products at cost savings of 40 to 70 percent.

Service Capability. Whether in the dealer's fully equipped shop or in the field, you will get trained service technicians using the latest technology and tools.

Selection. Make detailed comparisons of the machines you are considering before you buy. How long do components last? What is the cost of preventive maintenance? What is the true cost of lost production? Your Cat dealer can give you precise answers to these questions.

Purchase. Look past initial price. Consider the financing options available as well as day-to-day operating costs. This is also the time to look at dealer services that can be included in the cost of the machine to yield lower equipment owning and operating costs over the long run.

Operation. Improving operating techniques can boost your profits. Your Cat dealer has training videotapes, literature and other ideas to help you increase productivity.

Maintenance. More and more equipment buyers are planning for effective maintenance before buying equipment. Choose from your dealer's wide range of maintenance services at the time you purchase your machine. Repair option programs guarantee the cost of repairs up front. Diagnostic programs such as Scheduled Oil Sampling and Technical Analysis help you avoid unscheduled repairs.

Replacement. Repair, rebuild or replace? Your Cat dealer can help you evaluate the cost involved so you can make the right choice.

Engine

Four-stroke cycle, six cylinder 3306 turbocharged diesel engine.

Standard arrangement Ratings at 1900* RPM	kW	HP
Gross power	133	179
Net power	123	165

The following ratings apply at 1900 RPM when tested under the specific standard conditions for the specified standard:

NET POWER	kW	HP	PS
Caterpillar	123	165	—
ISO 9249	123	165	—
EEC 80/1269	123	165	—
SAE J1349	122	163	—
DIN 70020	—	—	171

Dimensions

Bore	121 mm	4.75 in
Stroke	152 mm	6.0 in
Displacement	10.5 liters	638 cu in

*Power rating conditions

- based on standard air conditions of 25°C (77°F) and 99 kPa (29.32 in Hg) dry barometer
- used 35° API gravity fuel having an LHV of 42 780 kJ/kg (18,390 Btu/lb) when used at 30°C (86°F) [ref. a fuel density of 838.9 g/L (7.001 lb/U.S. gal)]
- net power advertised is the power available at the flywheel when engine is equipped with fan, air cleaner, muffler and alternator
- no derating required up to:
 - 2300 m (7500 ft) altitude for standard arrangement
 - 2100 m (7000 ft) altitude for XL and XR arrangement (EEC)
 - 1600 m (5400 ft) altitude for LGP arrangement (EEC)
- meets 1996 CARB and EPA requirements, 1996 JMOC requirements, and anticipated 1998 EEC requirements

XL and XR arrangements Ratings at 1900* RPM	kW	HP
Gross power	141	189
Net power	130	175

The following ratings apply at 1900 RPM when tested under the specific standard conditions for the specified standard:

NET POWER	kW	HP	PS
Caterpillar	130	175	—
ISO 9249	130	175	—
EEC 80/1269	130	175	—
SAE J1349	129	173	—
DIN 70020	—	—	181

Dimensions

Bore	121 mm	4.75 in
Stroke	152 mm	6.0 in
Displacement	10.5 liters	638 cu in

Features

- direct injection fuel system with individual adjustment-free unit injectors
- 3-ring aluminum alloy pistons
- heat resistant sil-chrome steel intake and stellite-faced exhaust valves
- one-piece cylinder head designed with cast intake manifold
- direct electric 24-volt starting and charging system
- two 12-volt, 100 amp-hour, 750 CCA, maintenance-free batteries
- 70-amp alternator
- dry-type, radial-seal air cleaner with primary and secondary elements

Transmission

Three-speed planetary auto shift, remotely mounted from engine.

Speeds with power shift transmission approximate

		km/h	MPH
Forward	1	3.9	2.4
	2	6.8	4.2
	3	11.9	7.4
Reverse	1	4.8	3.0
	2	8.7	5.4
	3	15.3	9.5

LGP arrangements Ratings at 1900* RPM	kW	HP
Gross power	148	199
Net power	138	185

The following ratings apply at 1900 RPM when tested under the specific standard conditions for the specified standard:

NET POWER	kW	HP	PS
Caterpillar	138	185	—
ISO 9249	138	185	—
EEC 80/1269	138	185	—
SAE J1349	137	183	—
DIN 70020	—	—	191

Dimensions

Bore	121 mm	4.75 in
Stroke	152 mm	6.0 in
Displacement	10.5 liters	638 cu in

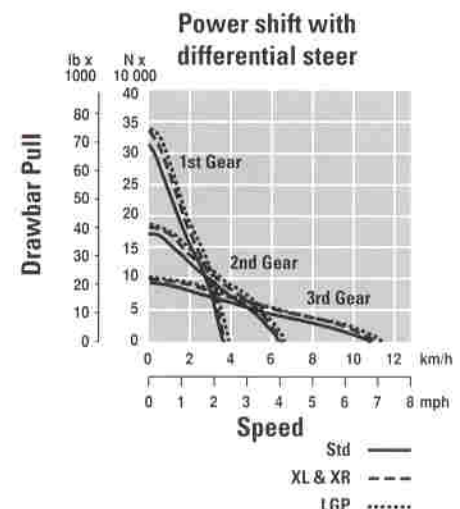
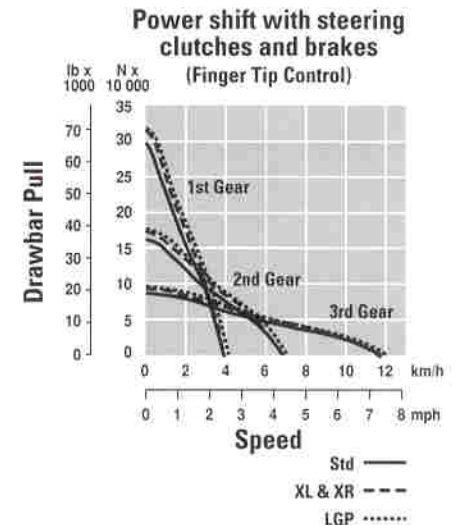

Hydraulic Controls

Load-sensing, variable displacement piston pump.

Pump capacity at 6895 kPa/69 bar /1000 psi

RPM at rated engine speed	2019	
Steering clutches and brakes model	190 liters/min	50.2 gpm
Differential steer model	196 liters/min	51.8 gpm
Tilt cylinder flow	80 liters/min	21.1 gpm
Main relief valve settings		
Differential steer model	42 000 kPa/420 bar	6090 psi
Steering clutches and brakes model	19 305 kPa/193 bar	2800 psi
Implement circuit pressures		
Bulldozer lift	19 305 kPa/193 bar	2800 psi
Bulldozer tilt	19 305 kPa/193 bar	2800 psi
Ripper	19 305 kPa/193 bar	2800 psi
Drive	geared from engine flywheel	

Control positions

- lift cylinders — raise, hold, lower, float
- tilt cylinder — left, right, hold
- angle cylinders — left, right, hold
- ripper cylinder — raise, hold, lower

Cab

Caterpillar cab and Rollover Protective Structure (ROPS).

ROPS canopy required in U.S.A.

Features

- meets OSHA and MSHA limits for operator and sound exposure with doors and windows closed (according to ANSI/SAE J1166 JUL87)
- ROPS meets the following criteria:
 - SAE J395
 - SAE J1040 APR88
 - ISO 3471-1 1986
 - ISO 3471-1 1994
- also meets the following criteria for Falling Objects Protective Structure:
 - SAE J231 JAN81
 - ISO 3449 1992 Level II

Note

When properly installed and maintained, the cab offered by Caterpillar, when tested with doors and windows closed according to ANSI/SAE J1166 MAY90, meets OSHA and MSHA requirements for operator sound exposure limits in effect at time of manufacture. The operator sound pressure level is 79 dB(A) when measured per ISO 6394 and 81 dB(A) when measured per ISO 6396.

Steering and Braking

Choice of Finger Tip Control or

Differential Steering

System meets SAE J1026 APR90.

Features — Finger Tip Control

- Finger Tip Control of transmission and steering clutches and brakes
- oil-cooled, electro-hydraulically actuated multiple-disc steering clutches and brakes
- single brake pedal brakes both tracks without disengaging steering clutches
- electro-hydraulically actuated, spring applied parking brake

Features — Differential Steering

- twist-grip tiller bar controls transmission and steering
- electro-hydraulically actuated planetary differential delivers uninterrupted power to both tracks while turning
- ability to counter-rotate tracks with transmission in neutral
- single brake pedal brakes both tracks
- electro-hydraulically actuated, spring applied parking brake

Heavy Duty Sealed and Lubricated Track

Heavy duty design for superior track life.

Features

- improved sealability and link rail wear life
- wider bushing strap provides improved bushing retention and resistance to bore stretching and cracking
- wider pin boss and longer pin improves pin-to-link retention
- more rail material increases link and roller system wear life
- extends undercarriage maintenance intervals
- reduces overall undercarriage operating costs

Service Refill Capacities

	Liters	Gallons
Fuel tank	383	101
Crankcase	27.5	7.3
Transmission, bevel gear and steering clutch (includes torque converter)	155	41
Final drives (each side)	13.5	3.6
Cooling system	74	19.5
Hydraulic System (tank only)	76	20

Pivot Shaft and Equalizer Bar

Pivot shaft and pinned equalizer bar oscillation system.

Features

- pivot shaft transmits ground impact loads directly to main frame
- protects power train components
- pinned equalizer bar keeps track roller frame in proper alignment
- system provides smooth machine underside

Final Drive

Single reduction final drives.

Features

- isolated from ground-impact and blade-induced loads
- modular design reduces removal and installation time
- segmented sprocket simplifies replacement

Track Roller Frame

Tubular design resists torsional loads.

Features

- Lifetime Lubricated rollers and idlers are directly mounted to roller frame
- oscillating roller frames attach to tractor by pivot shaft and pinned equalizer bar
- large pivot bushings operate in an oil reservoir
- equalizer bar saddle connection is low-friction bushing with remote lube line
- recoil system fully sealed and lubricated

	Standard		XL		XR		LGP	
Oscillation:								
front and rear idlers at gauge line	272 mm	10.7"	291 mm	11.5"	284 mm	11.2"	334 mm	13.1"
at pivot shaft	±3.0°		±3.0°		±3.0°		±2.9°	
Number of rollers (each side)	6		7		7		8	
Number of shoes (each side)	39		41		40		45	
Width of:								
standard shoes	560 mm	22"	560 mm	22"	560 mm	22"	915 mm	36"
optional shoes	610 mm	24"	610 mm	24"	610 mm	24"	760 mm	30"
extreme service	510 mm	20"	510 mm	20"	510 mm	20"	—	
	560 mm	22"	560 mm	22"	560 mm	22"	—	
self-cleaning	—	—	—	—	—	—	1000 mm	39"
Length of track on ground	2610 mm	102.7"	2821 mm	111.1"	2754 mm	108.4"	3243 mm	127.7"
Track gauge	1880 mm	74"	1880 mm	74"	1880 mm	74"	2225 mm	88"
Ground contact area with:								
560 mm (22") shoes	2.92 m ²	4518 in ²	3.16 m ²	4888 in ²	3.08 m ²	4770 in ²	—	
610 mm (24") shoes	3.18 m ²	4930 in ²	3.44 m ²	5332 in ²	3.36 m ²	5203 in ²	—	
760 mm (30") shoes	—	—	—	—	—	—	4.93 m ²	7662 in ²
915 mm (36") shoes	—	—	—	—	—	—	5.93 m ²	9194 in ²
self cleaning 1000 mm (39")	—	—	—	—	—	—	6.49 m ²	9961 in ²
Ground pressure:								
560 mm (22") shoes	.62 kg/cm ²	8.82 psi	.60 kg/cm ²	8.60 psi	.60 kg/cm ²	8.68 psi	—	
610 mm (24") shoes	.57 kg/cm ²	8.14 psi	.56 kg/cm ²	7.93 psi	.56 kg/cm ²	8.01 psi	—	
760 mm (30") shoes	—	—	—	—	—	—	.41kg/cm ²	5.80 psi
915 mm (36") shoes	—	—	—	—	—	—	.35kg/cm ²	4.94 psi
self cleaning 1000 mm (39")	—	—	—	—	—	—	.32kg/cm ²	4.55 psi

Weight (approximate)

Shipping weight

Includes two-valve hydraulic control, lubricants, coolant, ROPS canopy and 10% fuel.

	Standard		XL		XR		LGP	
Power shift with Finger Tip Control	14 800 kg	32,600 lb	15 500 kg	34,200 lb	15 000 kg	33,100 lb	17 200 kg	37,900 lb
Power shift with differential steering	15 100 kg	33,200 lb	15 700 kg	34,600 lb	15 200 kg	33,560 lb	17 400 kg	38,300 lb

Operating weight

Includes above plus blade with tilt cylinder, shoes, drawbar, operator and full fuel tank.

Attached blade	Standard with 6S		XL with 6SU		XR with 6A		LGP with 6S	
Power shift with Finger Tip Control	18 000 kg	39,700 lb	19 000 kg	41,900 lb	18 300 kg	40,400 lb	20 500 kg	45,200 lb
Power shift with differential steering	18 200 kg	40,100 lb	19 200 kg	42,300 lb	18 500 kg	40,800 lb	20 700 kg	45,600 lb

Bulldozer Specifications

Blade	Blade Capacity (SAE J1265)		Blade Width (over end bits)		Blade Height		Digging Depth		Ground Clearance		Maximum Tilt		Weight (without hyd. controls)		Total Operating Weight* (with blade)	
	m ²	yd ³	mm	ft. in.	mm	in.	mm	in.	mm	in.	mm	in.	kg	lb	kg	lb
6S, Std/XR:	3.89	5.09	3360	11'0"	1257	49.5"	473	18.6"	1104	43.5"	765	30.1"	2599	5731	18 000 ¹	39,700 ¹
6SU, Std/XR:	5.61	7.34	3260	10'8"	1412	55.6"	473	18.6"	1104	43.5"	743	29.3"	2699	5951	18 100 ¹	39,900 ¹
6A, Std/XR:																
Straight	3.18	4.16	4166	13'8"	1034	40.7"	506	19.9"	1142	45.0"	408	16.1"	2727	6013	18 100 ¹	39,900 ¹
Angled 25°	—	—	3785	12'5"	—	—	—	—	—	—	—	—	—	—	—	—
6SU XL	5.61	7.34	3260	10'8"	1411	55.6"	459	18.1"	1195	47.0"	743	29.3"	2973	6555	19 000	41,900
6A XL:																
Straight	3.93	5.14	4165	13'8"	1155	45.5"	524	20.6"	1205	47.5"	408	16.1"	3109	6855	19 150	42,200
Angled 25°	—	—	3778	12'5"	—	—	—	—	—	—	—	—	—	—	—	—
6S LGP	3.70	4.83	3990	13'1"	1101	43.3"	655	25.8"	1083	42.6"	701	27.6"	2801	6176	20 500	45,200

*Operating weight includes power shift (steering clutches and brakes) arrangement, lubricants, coolant, full fuel tank, 2 valve hydraulic controls, blade with tilt cylinder, ROPS canopy, drawbar, standard shoe.

¹Operating weight of standard arrangement with blade.

Dimensions

(approximate)

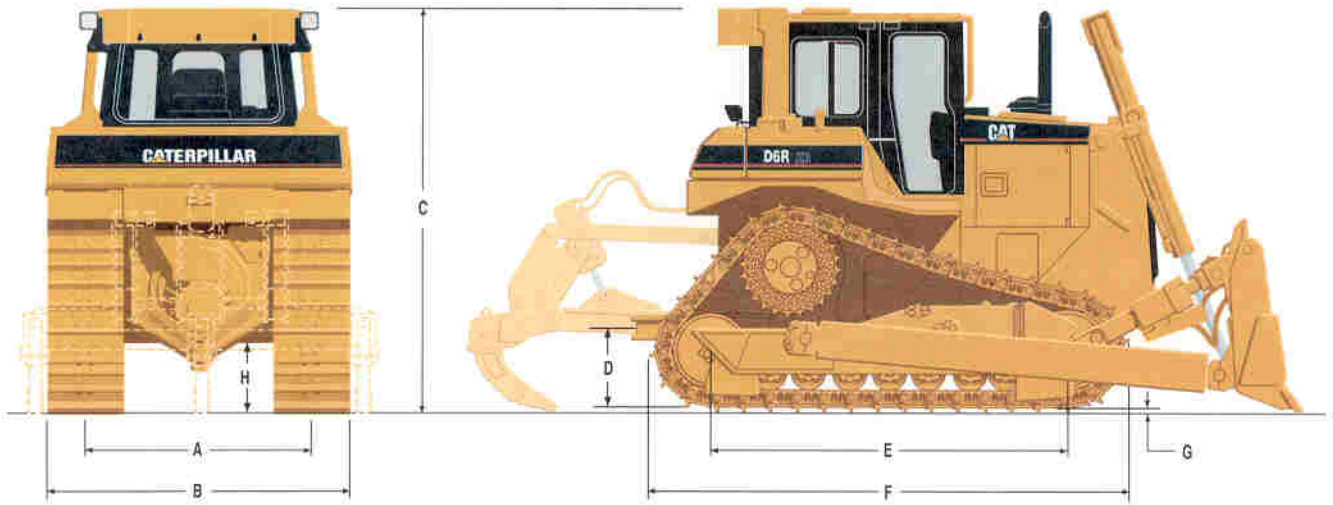

Tractor Dimensions

	Standard		XL		XR		LGP	
A. Track gauge	1880 mm	74"	1880 mm	74"	1880 mm	74"	2225 mm	88"
B. Width of tractor								
Over trunnions	2640 mm	8' 8"	2640 mm	8' 8"	2640 mm	8' 8"	3428 mm	11' 3"
Without trunnions (std. shoe width)	2440 mm	8' 0"	2440 mm	8' 0"	2440 mm	8' 0"	3140 mm	10' 4"
C. Machine height from tip of grouser:								
Stack	3094 mm	10' 1.8"	3094 mm	10' 1.8"	3094 mm	10' 1.8"	3144 mm	10' 3.8"
ROPS	3195 mm	10' 5.8"	3195 mm	10' 5.8"	3195 mm	10' 5.8"	3245 mm	10' 7.8"
D. Drawbar height (center of clevis) from ground face of shoe	511 mm	20.1"	511 mm	20.1"	511 mm	20.1"	567 mm	22.3"
E. Length of track on ground	2610 mm	102.7"	2821 mm	111.1"	2754 mm	108.4"	3243 mm	127.7"
F. Length of basic tractor (with drawbar)	4069 mm	13' 4"	4069 mm	13' 4"	4217 mm	13' 10"	4493 mm	14' 9"
With the following attachments, add to basic tractor length:								
Ripper (with tip at ground line)	1186 mm	46.7"	1186 mm	46.7"	1038 mm	40.9"	—	
Winch	300 mm	11.8"	300 mm	11.8"	146 mm	5.7"	146 mm	5.7"
SU blade	1235 mm	48.6"	1472 mm	58"	1235 mm	48.6"	—	
S blade	1043 mm	41.1"	—		1043 mm	41.1"	1218 mm	48"
A blade	1147 mm	45.2"	1349 mm	53.1"	1147 mm	45.2"	—	
G. Height of grouser	65 mm	2.6"	65 mm	2.6"	65 mm	2.6"	65 mm	2.6"
H. Ground clearance	383 mm	15.1"	383 mm	15.1"	383 mm	15.1"	433 mm	17.1"

Winch

Rugged PA56 winch with freespool.*

Features

- hydraulically actuated multiple-disc wet clutch and brake
- single lever control of clutch and brake functions
- separate lever for freespool operation

Weight	1135 kg	2503 lb
Winch length	1200 mm	47.2"
Winch case width	975 mm	38.3"
Flange diameter	330 mm	13.0"
Drum width	254 mm	10.0"
Drum diameter	260 mm	10.25"

Cable size:

Recommended	22 mm	0.88"
Optional	25 mm	1.0"

Drum capacity:

Recommended cable	88 m	290'
Optional cable	67 m	220'

Oil capacity	67 L	17.7 gal
--------------	------	----------

Cable/ferrule sizes

(OD x length)	54 mm x 67 mm	2.10" x 2.63"
---------------	---------------	---------------

*PA56 winch is manufactured for Caterpillar by PACCAR Inc.

Ripper

Multi-shank parallelogram design lets you choose one, two or three shanks to match the job conditions.

Beam width	2202 mm	86.7"
Beam cross section	216 mm x 254 mm	8.5" x 10"
Maximum penetration	500 mm	19.7"
Maximum clearance raised (shank tip)	511 mm	20.1"
Number of pockets		3
Maximum penetration force	6603 kg	14,557 lb
Maximum pryout force	9134 kg	20,137 lb
Weight		
With one shank	1606 kg	3541 lb
Each additional shank	74 kg	163 lb

Standard Equipment

Note: Standard and optional equipment may vary. Consult your Caterpillar dealer for specifics.

Advanced Modular Cooling System (AMOCS)	Direct electric starting, 24-volt	ROPS canopy
Air cleaner with precleaner	Dust ejector	Seat belt
Alternator, 70-amp	Ecology drains (engine oil & coolant, hydraulic oil, fuel tank sediment)	Steering system:
Arm rests, adjustable	End guiding guards	Differential Steering or
Automatic shifting features:	3306 DIT low emissions engine	Finger Tip Control
Auto-kickdown (auto-downshift)	Ether starting aid	Seat, vinyl, suspension, with adjustable
Auto shift (2R-1F, 2F-2R)	Electronic power shift transmission	armrest and (contour series)
Back up alarm	Front pull device	Track, Heavy Duty Sealed and
Blower fan	Gauge package, temperature	Lubricated:
Caplocks	Coolant	Standard arrangement
Carrier Roller (XL and LGP models)	Transmission oil	560mm (22"), 39-section
Caterpillar Monitoring System	Hinged radiator grill	XL arrangement
Center track guiding guards (LGP)	Horn	560mm (22"), 41-section
Cooler, hydraulic oil (differential steer models)	Hydraulic track adjusters	XR arrangement
Crankcase guard	Hydraulic, two-valve, lift and tilt	560mm (22"), 40-section
Decelerator	Instrument panel guard	LGP arrangement,
	Lifetime lubricated track rollers and idlers	915mm (36"), 45-section
	Load-sensing hydraulic system	Vandalism covers and locks
	Muffler	
	Rearview mirror	

Optional Equipment

(with approximate change in operating weights*)

	Kg	Lb		Kg	Lb
Air conditioner	57	125	High-flange track roller guiding arrangement		
Arm rest adjustment, electric (for Finger Tip Control models)	0	0	Standard	34	75
Batteries, heavy duty	60	132	XL and XR	38	84
Bulldozers (see page 16 for weights)			LGP	43	95
Cab, ROPS			Hook, heavy duty, front pull	12	26
(Sound suppressed, includes air pressurizer, heater, cloth contour series seat, seat belt, radio mounting and speakers, front and rear windshield wipers and washers, air filter, rearview mirror and key locks)	363	800	Hydraulic controls, third valve (additional valve for ripper)	37	81
Canopy, ROPS, removed (standard in U.S.A.)	-383	-845	Lighting system, four Halogen lights	13	29
Differential Steering System (listed for weight)	401	884	Prescreener	3	6
Drawbar:			Radiator core protector grid	22	49
Rigid, for use with Std/XL	106	234	Ripper, includes one tooth	1564	3449
Rigid, for use with XR/LGP	116	256	Screen, rear, for cab or canopy	59	130
Ecology drains (transmission, torque converter, main case)	3	7	Seat, vinyl, suspension-low back	-6	-13
Engine coolant heater	1	3	Sweeps, logging, canopy or cab	354	779
Engine enclosure (with perforated side panels)			Tilt cylinders, dual hydraulic, for angle dozers	152	335
Normal duty	44	97	Tracks, pair, Heavy Duty Sealed and Lubricated:		
Heavy duty	63	139	Standard roller frame only (39 section)		
Fan, reversible	7	15	560 mm (22") MS/RBT	-61	-136
Guards:			610 mm (24") MS/RBT	64	142
Bottom, heavy duty	64	140	510 mm (20") ES/HD	201	444
Bottom, extreme duty	142	312	560 mm (22") ES/HD	358	790
Fuel tank	129	284	610 mm (24") MS/HD	125	275
Precleaner	10	22	XL roller frame only (41 section)		
Grill, heavy duty, louver	30	66	560 mm (22") MS/RBT	-64	-142
Grill, heavy duty, punched hole	24	53	610 mm (24") MS/RBT	67	147
Radiator chin, heavy duty	13	29	510 mm (20") ES/HD	212	467
Rear, heavy duty	43	95	560 mm (22") ES/HD	377	830
Track guiding, center only:			610 mm (24") MS/HD	131	289
Standard, XL and XR	52	114	XR roller frame only (40 section)		
Track roller guards, full length:			510 mm (20") ES/HD	207	455
Standard	156	343	560 mm (22") ES/HD	367	810
XL	183	404	610 mm (24") MS/HD	128	282
XR	172	380	LGP roller frame only (45 section)		
LGP	154	339	760 mm (30") MS/HD	-446	-984
			760 mm (30") MS/RBT	-518	-1143
			915 mm (36") MS/RBT	-72	-159
			1000 mm (39") Self Cleaning/HD	-43	-95
			Winch	1135	2503
			Winch fairlead — three roller	293	645
			Winch fairlead — four roller	320	705

*Specifications are converted from British to metric measure and rounded.

ES=Extreme service shoes, MS=Moderate service shoes,
HD=Heavy duty link track, RBT = Rotating bushing track.